

# II PREDAVANJE

## PRAVILNI POLIEDRI

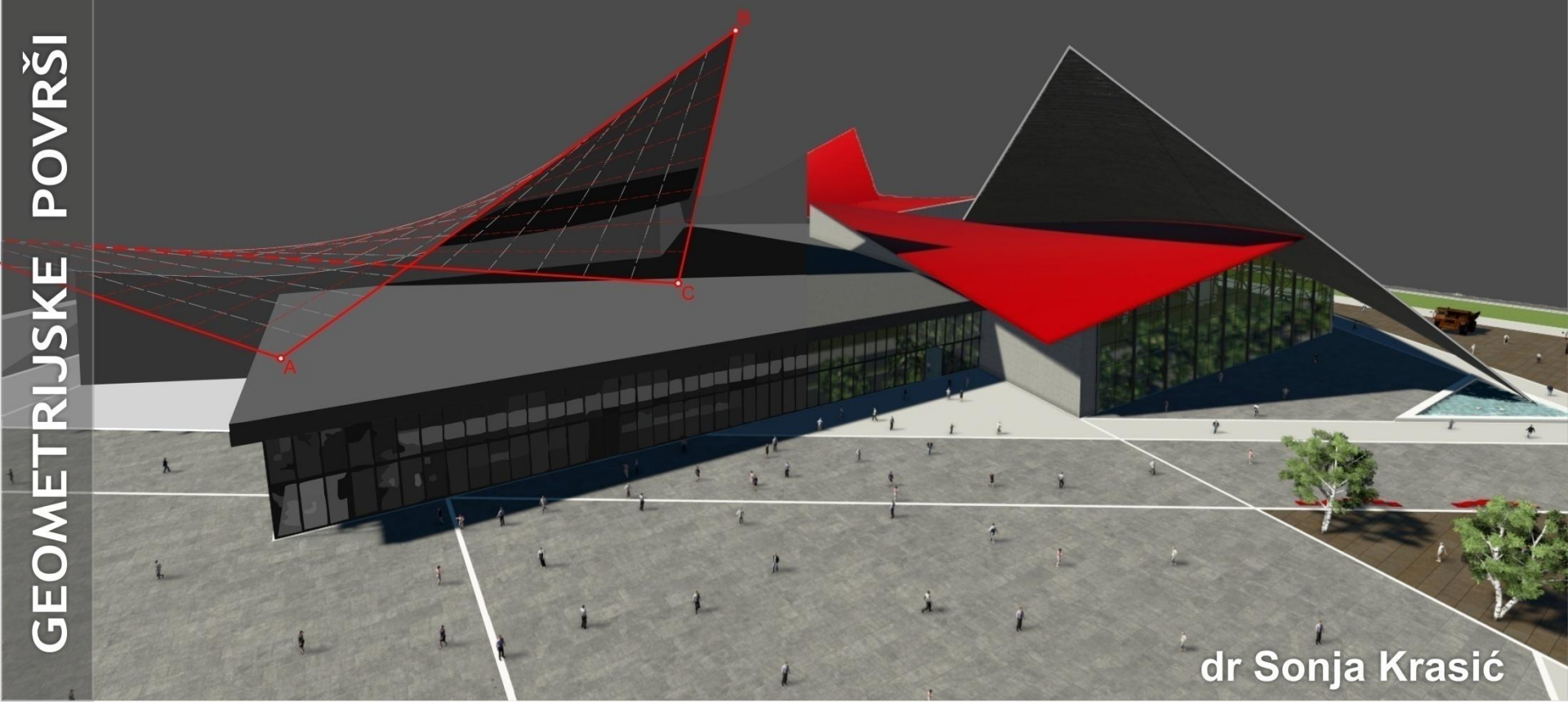



# GEOMETRIJSKE POVRŠI U ARHITEKTURI

## I PRAVOIZVODNE POVRŠI

### I.1. RAZVOJNE:

#### I.1.1. POLIEDARSKE

##### I.1.1.1. **Pravilni poliedri**

##### I.1.1.2. Piramide i prizme

#### I.1.2. JEDNOSTRUKO-ZAKRIVLJENE

##### I.1.2.1. Konusi i oblice

##### I.1.2.2. Konvolutne površi

### I.2. NERAZVOJNE:

#### I.2.1. JEDNOSTRUKO-IZVODNE

##### I.2.1.1. Helikoidi

##### I.2.1.2. Cilindroidi

##### I.2.1.3. Konoidi

##### I.2.1.4. Tetroidi

#### I.2.2. DVOSTRUKO-IZVODNE

##### I.2.2.1. Jednograni obrtni hiperboloid

##### I.2.2.2. Jednograni eliptični hiperboloid

##### I.2.2.3. Hiperbolički paraboloid

## II DVOSTRUKO ZAKRIVLJENE POVRŠI

### II.1. OPŠTE POVRŠI

#### II.1.1. LOPTA (SFERA)

#### II.1.2. ELIPSOID

#### II.1.3. PARABOLOID

#### II.1.4. DVOGRANI HIPERBOLOID

### II.2. OBRTNE POVRŠI

#### II.2.1. OPŠTE

#### II.2.2. TORUSI

### II.3. KLIZNE (TRANSLACIJSKE) POVRŠI

## POLIEDARSKE POVRŠI

- **pravilni poliedri**  
(platonova i  
arhimedova tela)
- **piramide**
- **prizme**

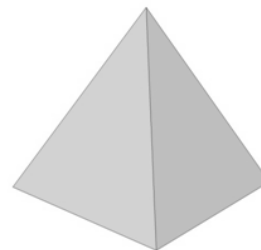
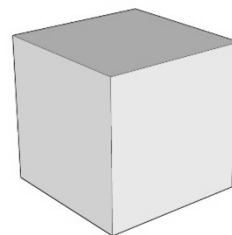

# PRAVILNI POLIEDRI

## PLATONOVA TELA

Sve strane (pljosni), pravilni mnogouglovi

ravnostrani trouglovi

kvadrati

pravilni petouglovi

### 5 Platonovih tela

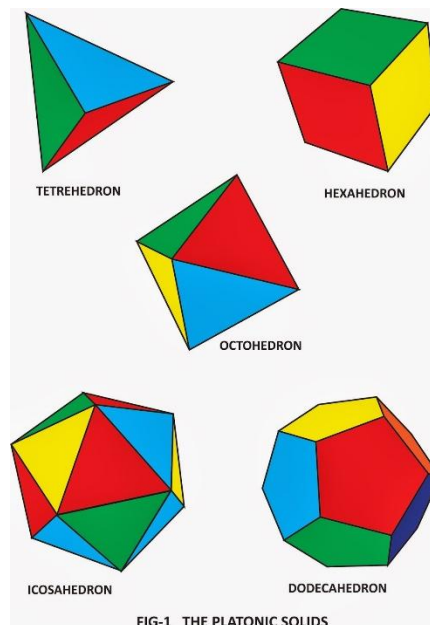



# PRAVILNI POLIEDRI

## ARHIMEDOVA TELA

Sve strane (pljosni), pravilni mnogouglovi

ravnostrani trouglovi

kvadrati

pravilni petouglovi

šestouglovi

osmouglovi

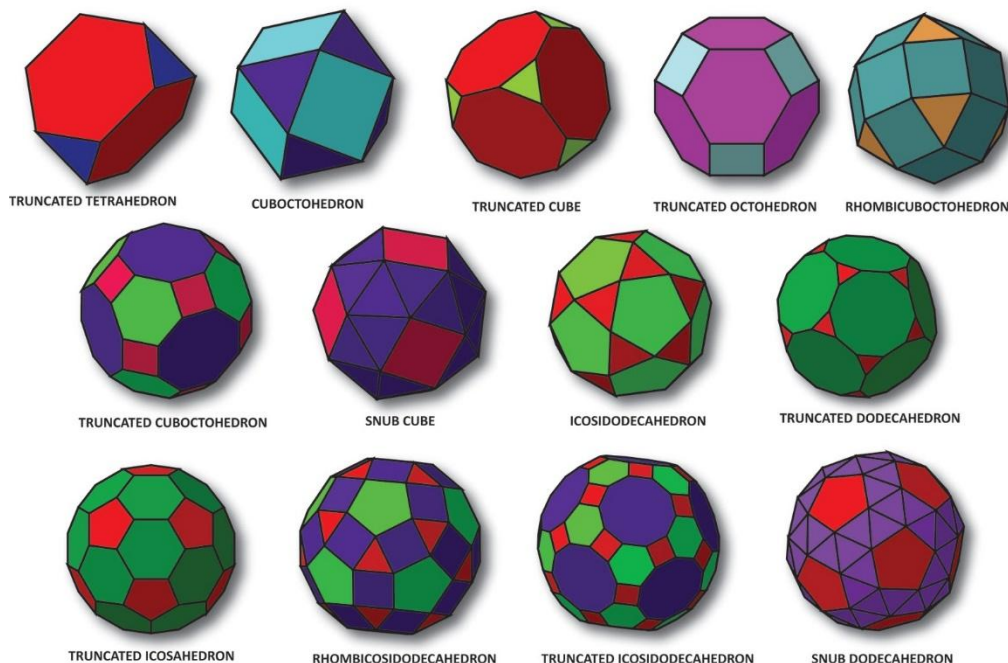

# 13 Arhimedovih tela

## Podela pravilnih poliedara (Platonovih tela):

- Tetraedar
- Heksaedar (kocka)
- Oktaedar
- Pentagonalni dodekaedar
- Ikosaedar

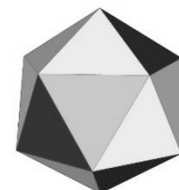
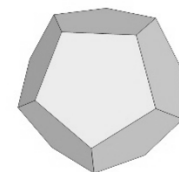
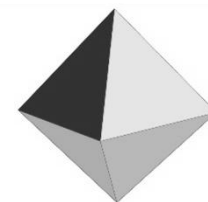
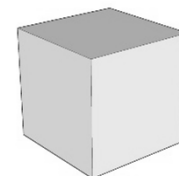
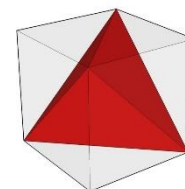

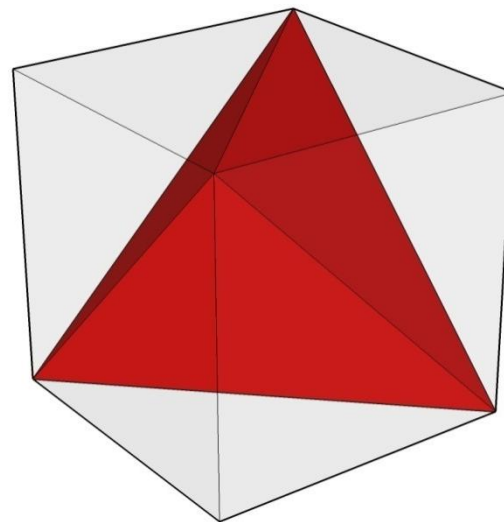

- **Tetraedar** - sastoji se od **četiri pljosni** (ravnostrani trouglovi), četiri roglja u kojima se susstiču tri trougla i **šest jednakih ivica**, stranica trouglova.

# TETRAEDAR

## Karakteristične projekcije

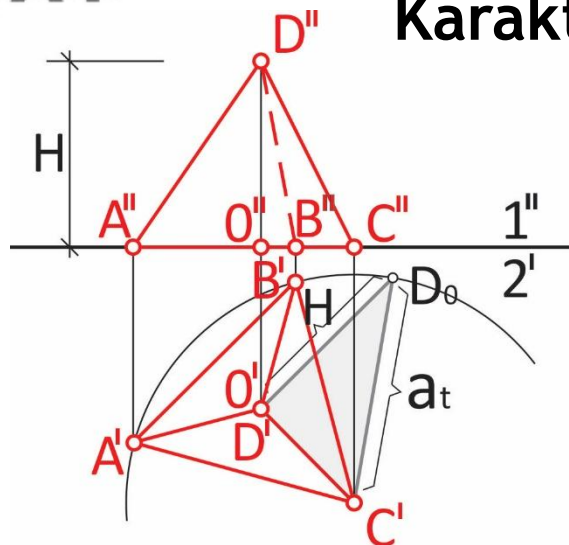

$$a_t = a_k \sqrt{2}, \quad H = \frac{2}{3} a_k \sqrt{3}$$

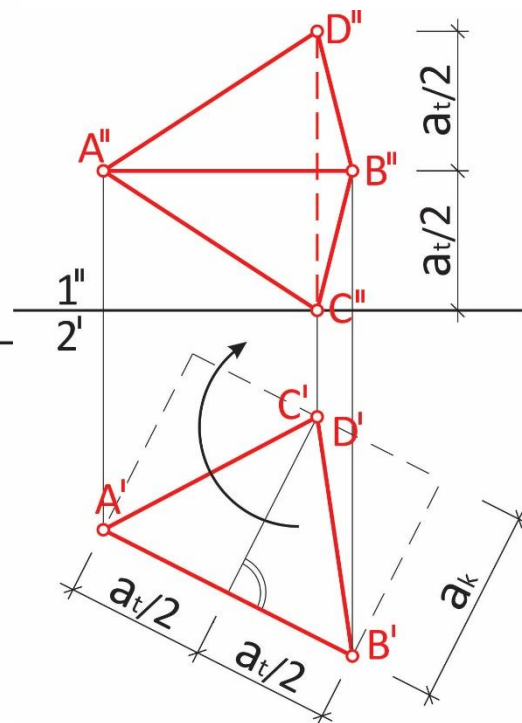
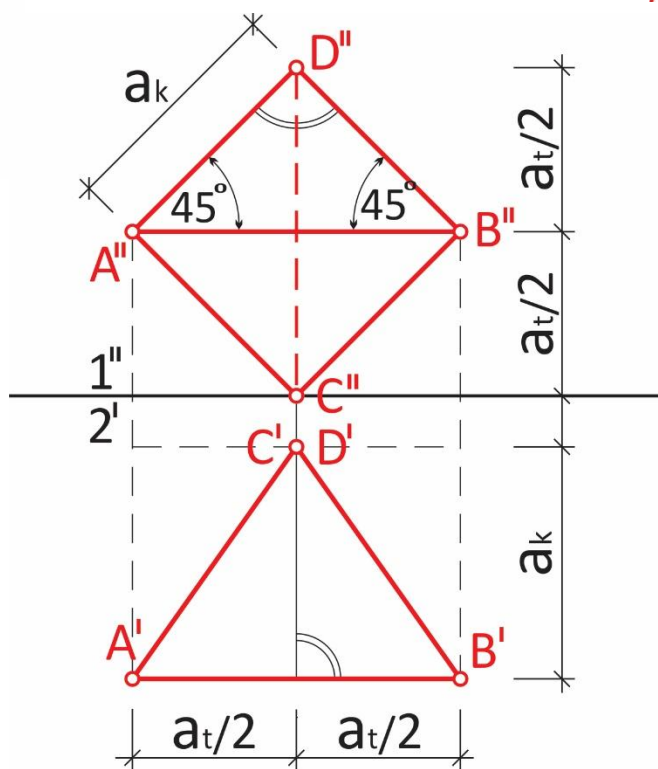
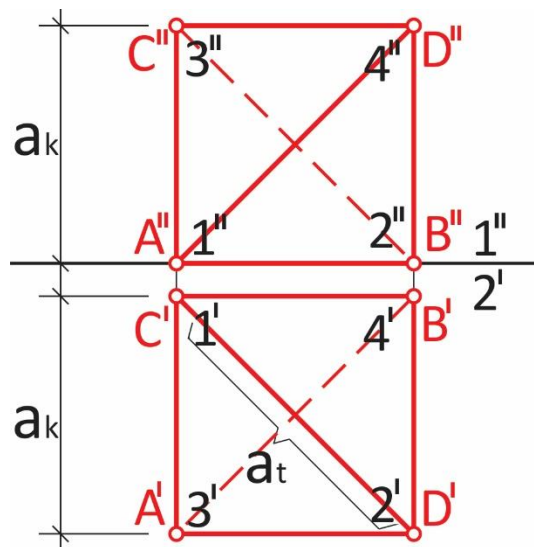
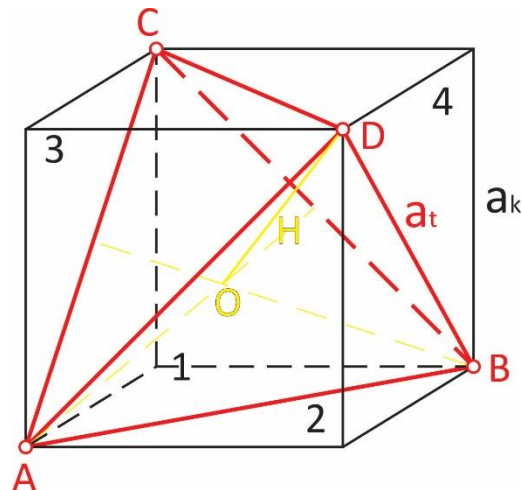

# TETRAEDAR

## Ravni preseki

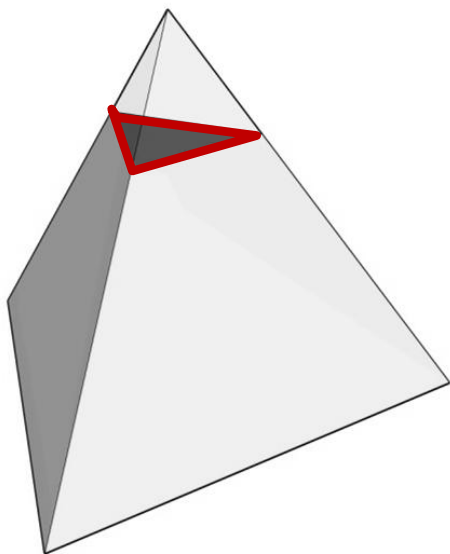

Sl. 1

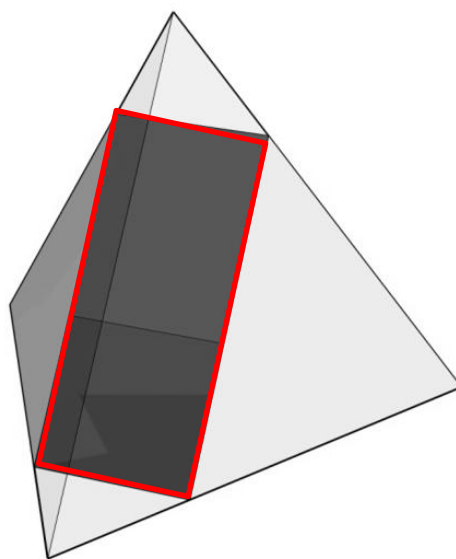

Sl. 2

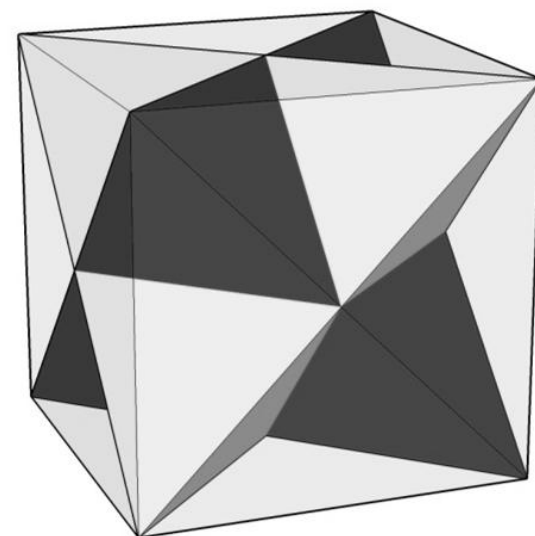

Sl. 3

## Prodori

# TETRAEDAR

## Mogućnosti spajanja i primena

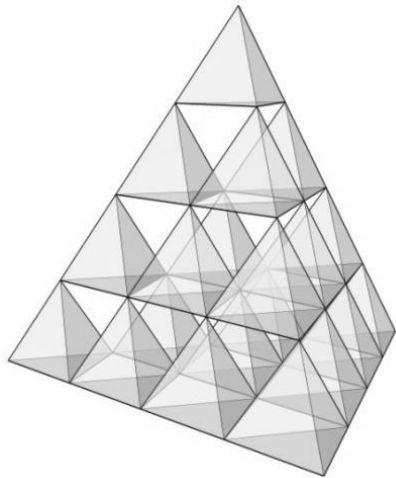

Sl. 1

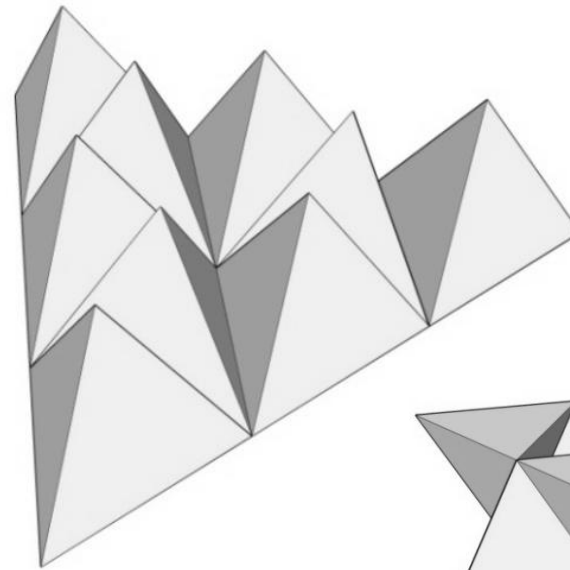

Sl. 2

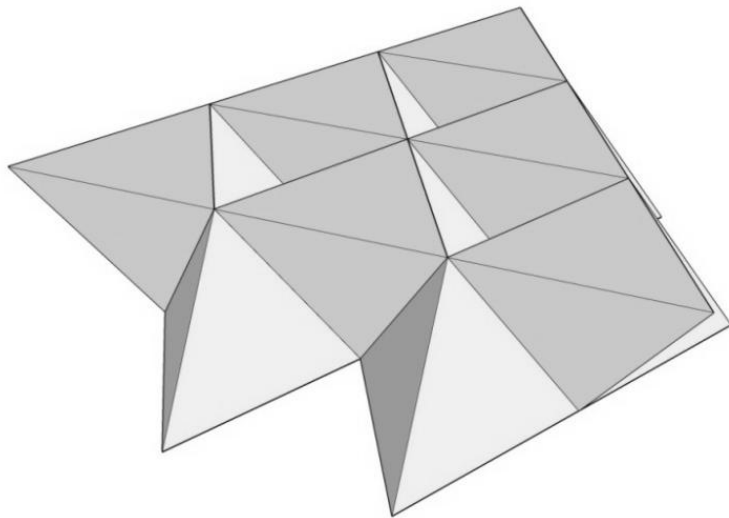

Sl. 3

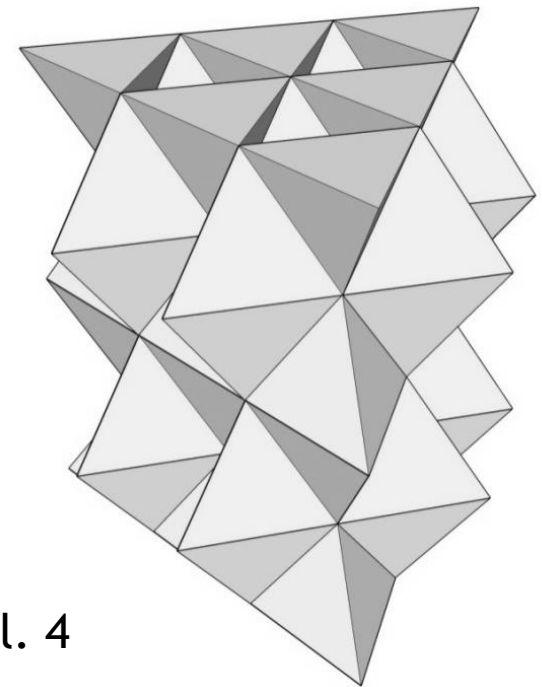

Sl. 4



- **Zasečeni tetraedar** - sastoji se od **osam pljosni** (4 ravnostrana trougla i 4 pravilna šestougla), dvanaest roglja u kojima se sutiču trouglovi i šestouglovi i **osamnaest ivica**.



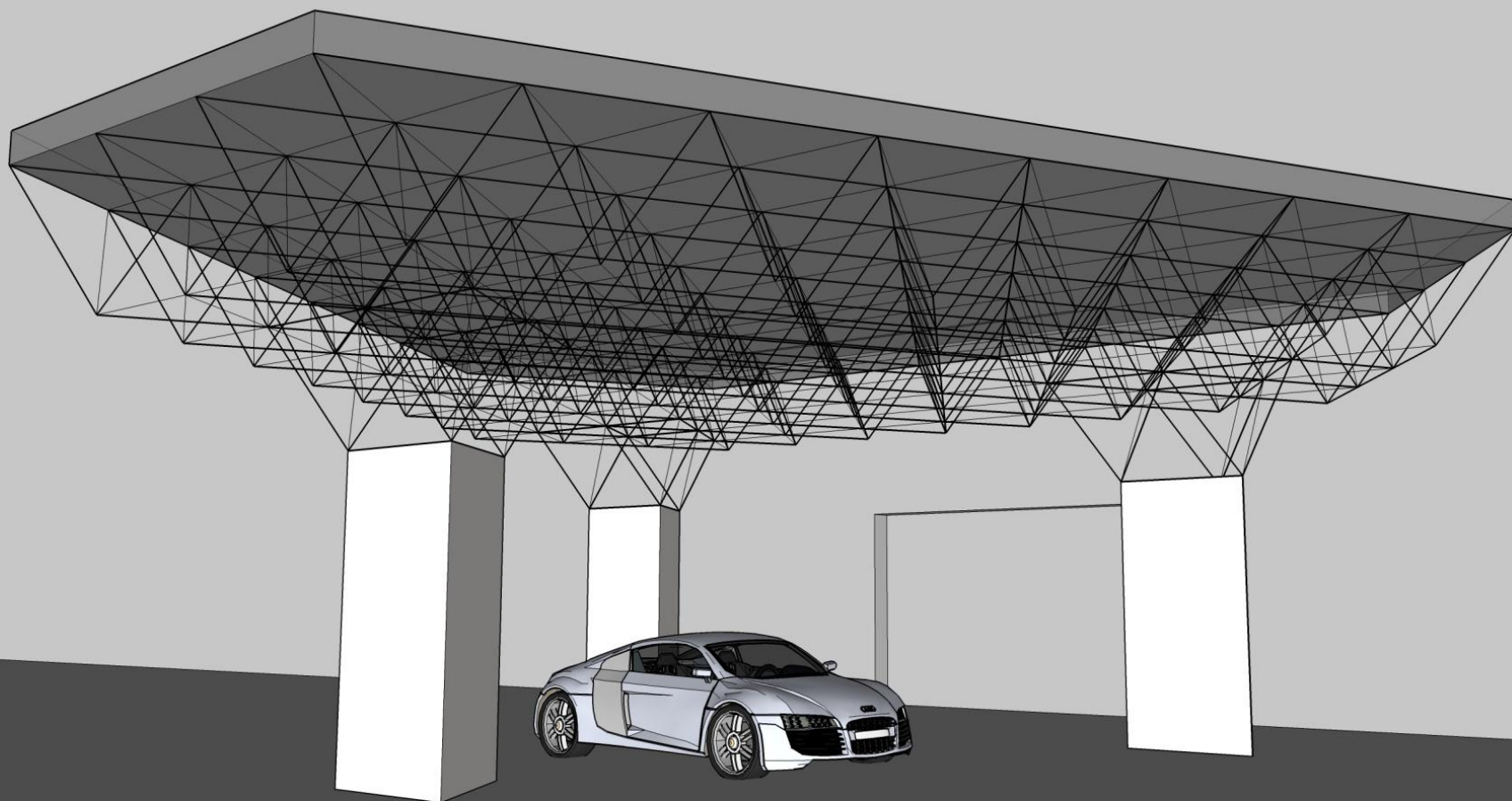

Konstruktivni sistem nadstrešnice



## Primena tetraedra u arhitekturi



**Krov crkve Sv. Matija**, Francuska, arh. Bazil Spence

## Primena tetraedra u arhitekturi

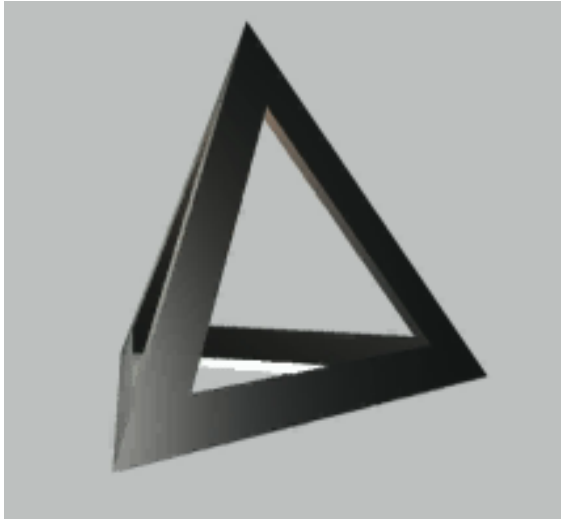

**Muzej savremene  
umetnosti**, MOCA, Nagi,  
Japan, arh. A. Isozaki, 1994.g





## Primena tetraedra u arhitekturi

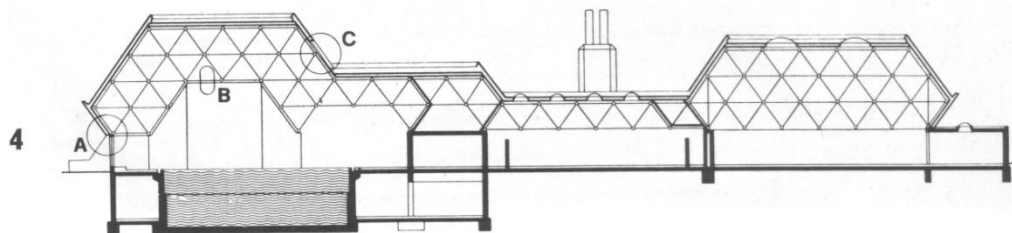

**Gimnazija u Metzingenu**, arh. P. L. Dolmetsch i W. Hang

## Primena tetraedra u arhitekturi

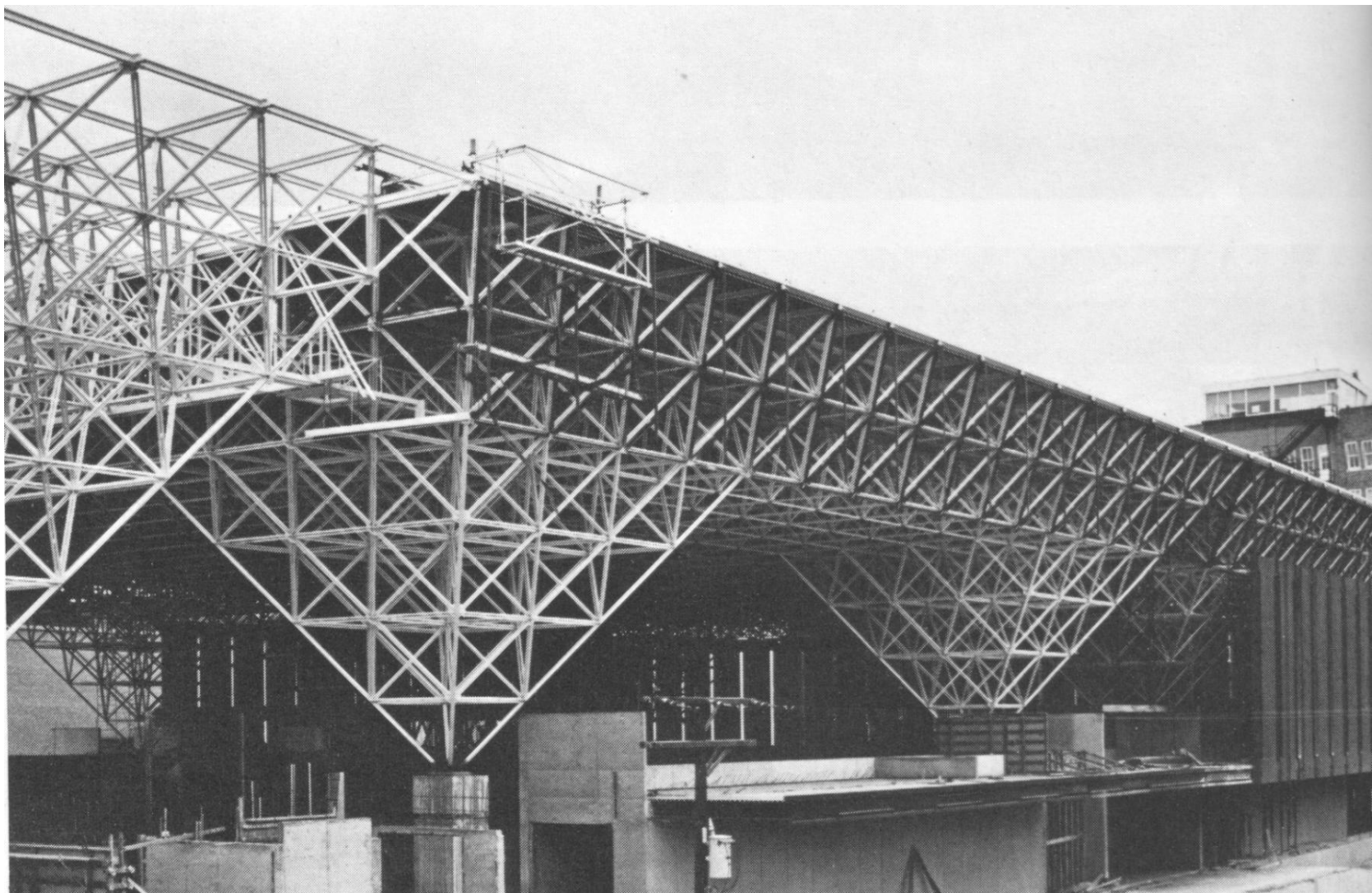

**Kolorado kongresni centar**, Denver, USA, arh. Curtis Fentress and architects, 1977.g



## Primena tetraedra u arhitekturi



**Kolorado kongresni centar**, Denver, USA, arh. Curtis Fentress and architects, 1977.g.

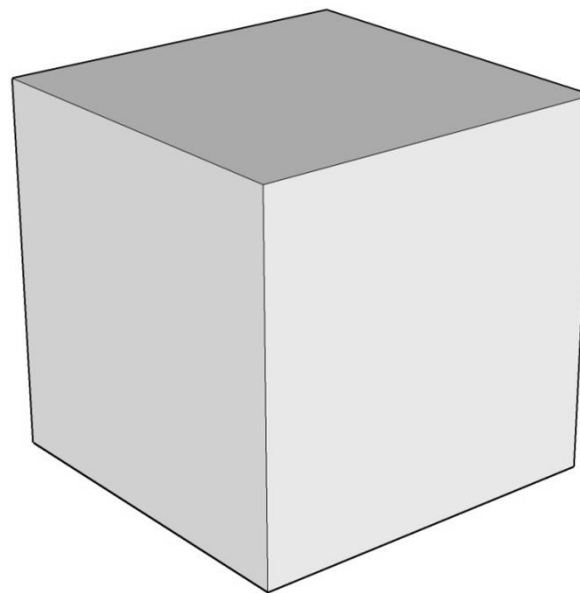

• **Heksaedar (kocka)** - sastoji se od **šest pljosni** (kvadrati), osam roglja u kojima se susstiču tri kvadrata i **dvanaest jednakih ivica**, stranica kvadrata.

# HEKSAEDAR (KOCKA)

Konstruktivno  
određivanje veličina  
ivica i dijagonala kocke

$$d = a\sqrt{2}, D = a\sqrt{3}$$

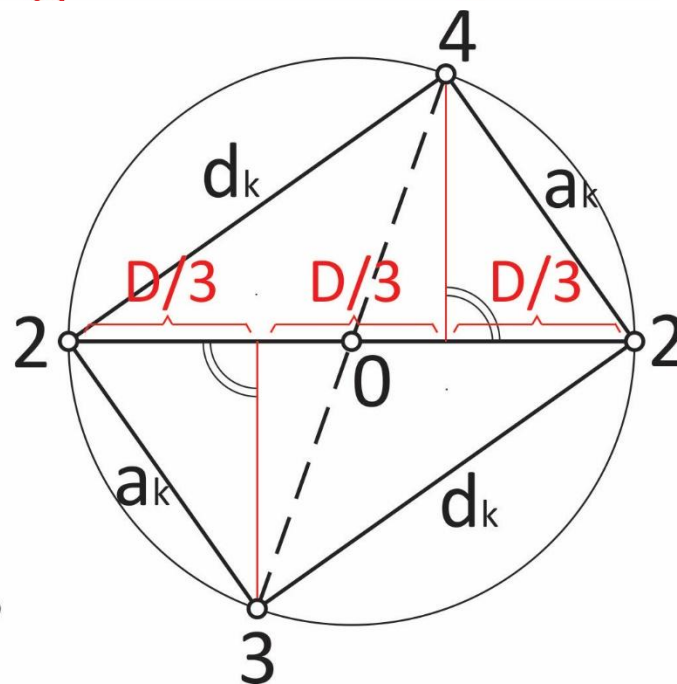
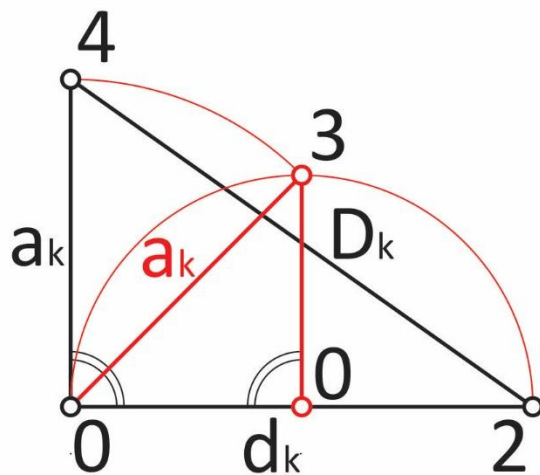
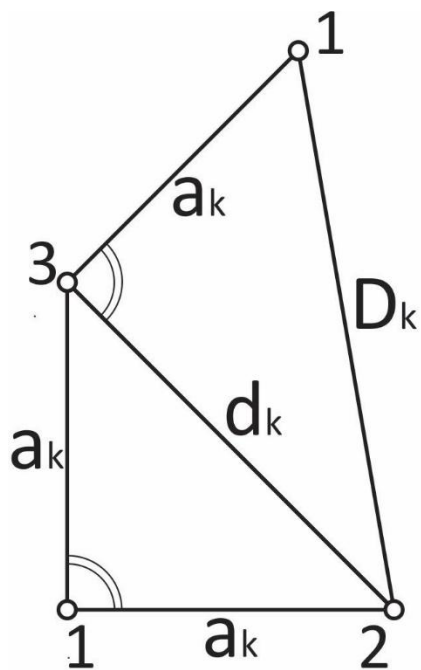
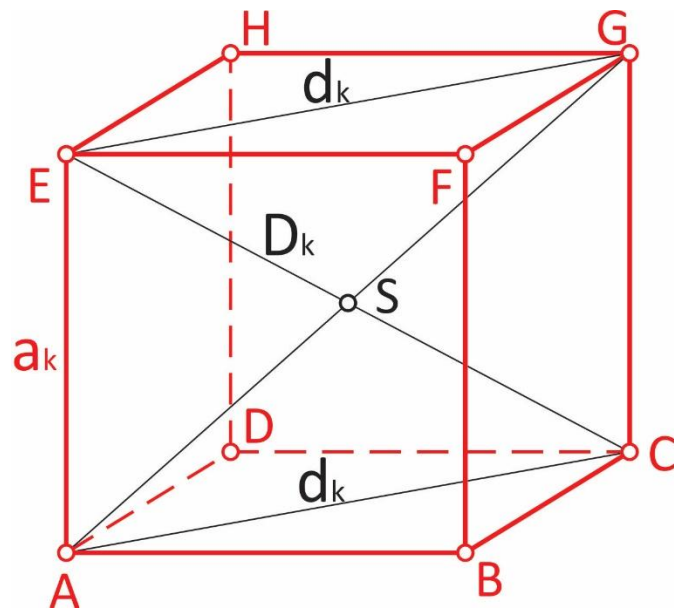

# HEKSAEDAR (KOCKA)

## Karakteristične projekcije

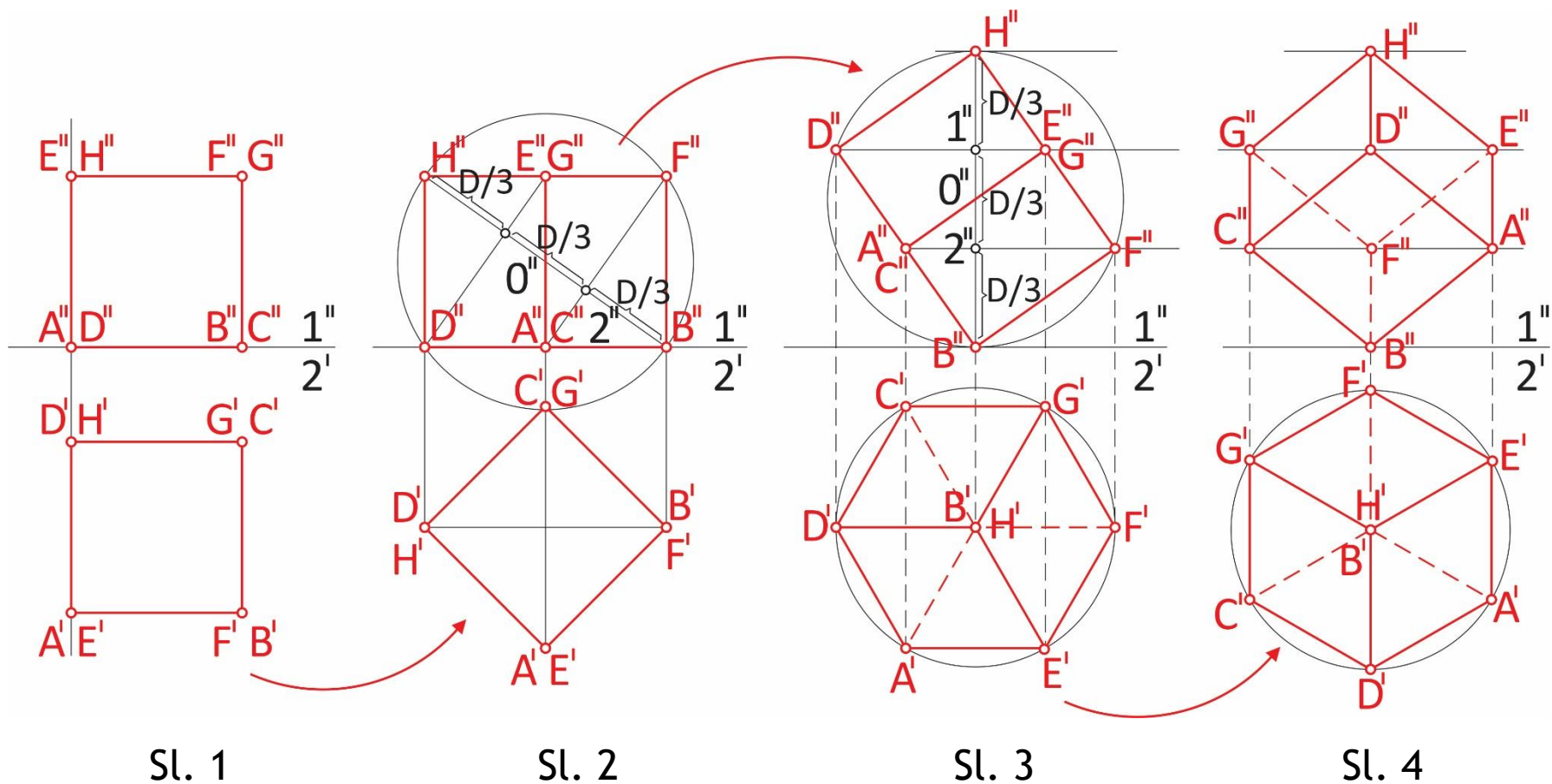



# HEKSAEDAR (KOCKA)

## Ravni preseki

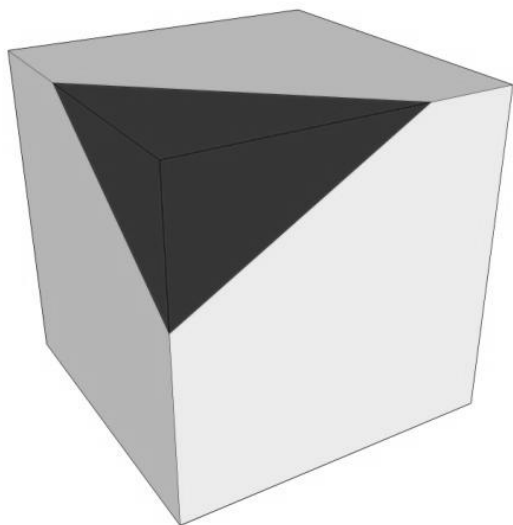

Sl. 1

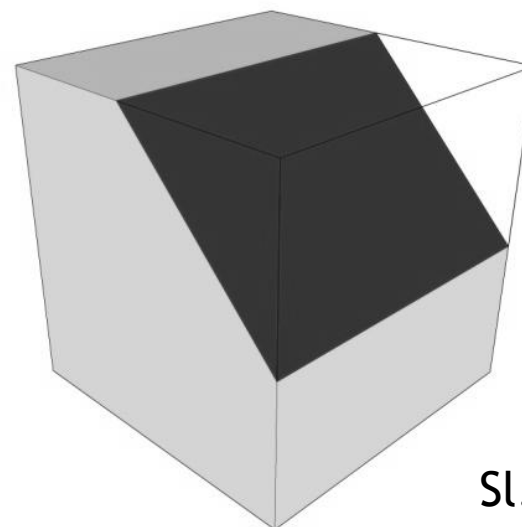

Sl. 2

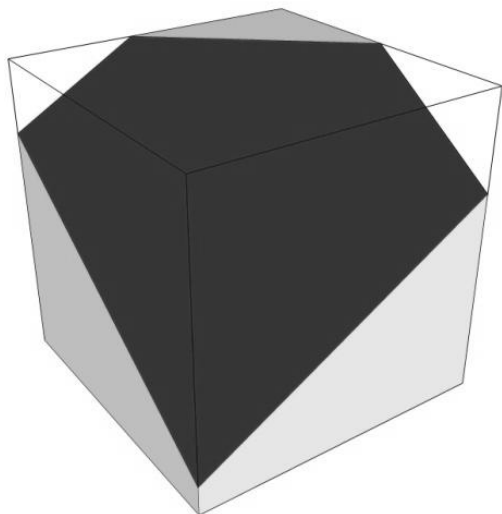

Sl. 3

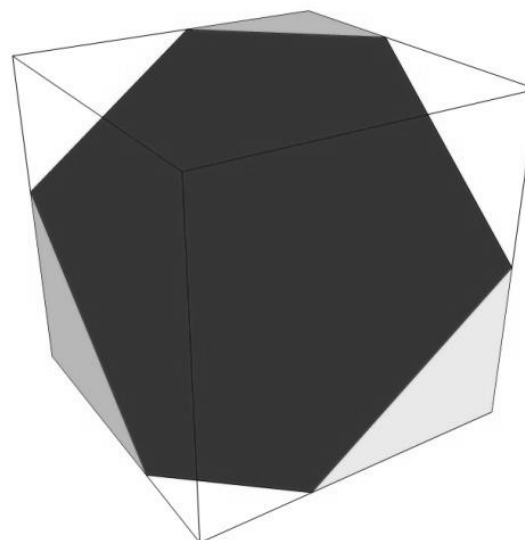

Sl. 4



# HEKSAEDAR (KOCKA)

Prodori

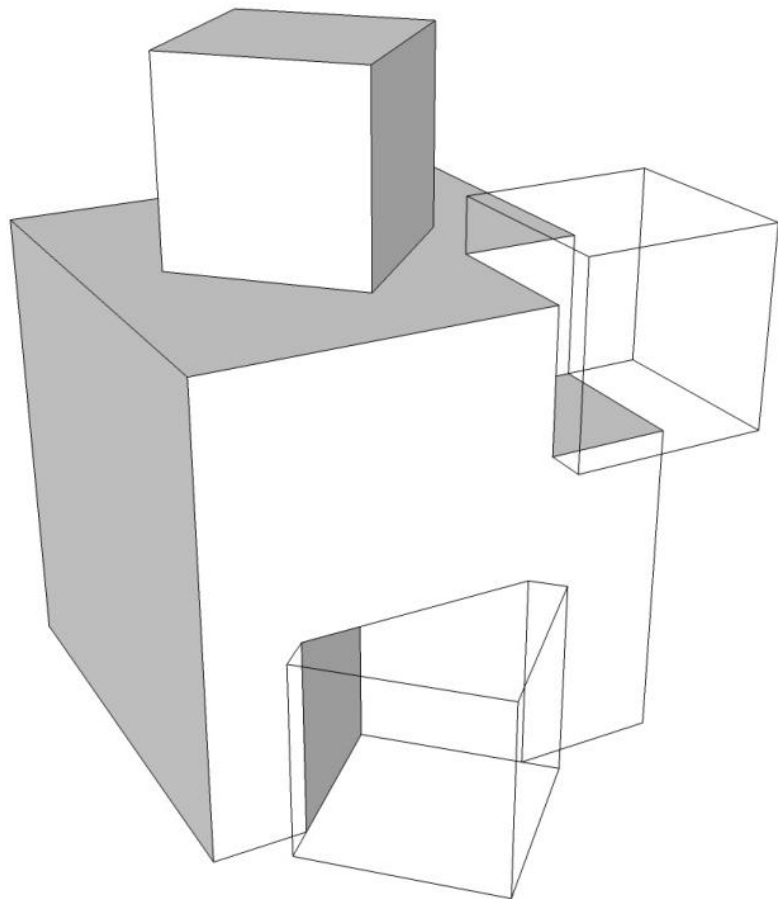

Sl. 1

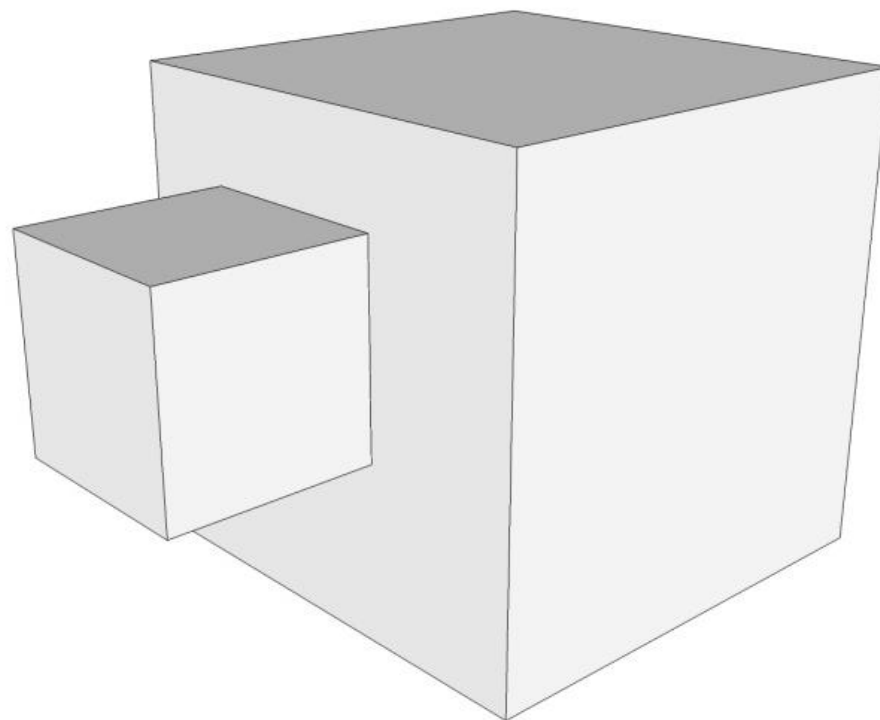

Sl. 2

# HEKSAEDAR (KOCKA)

## Mogućnosti spajanja i primena

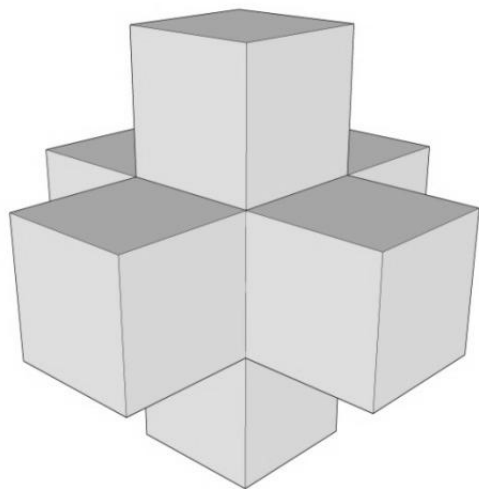

Sl. 1

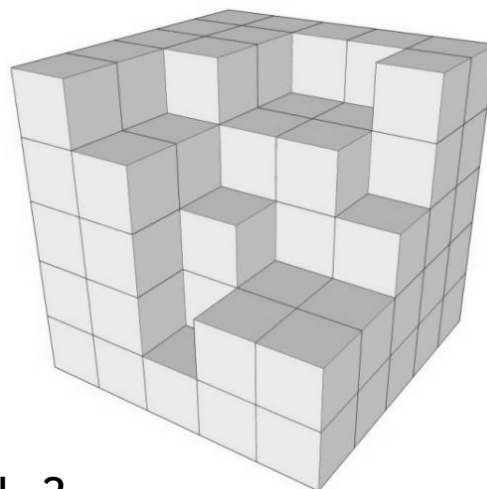

Sl. 2

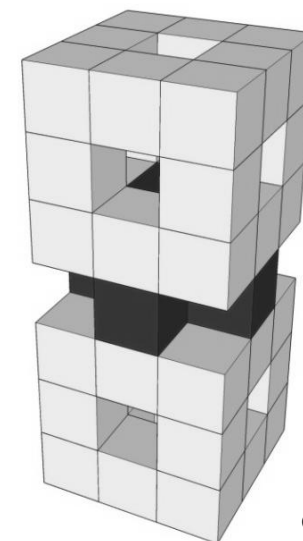

Sl. 3

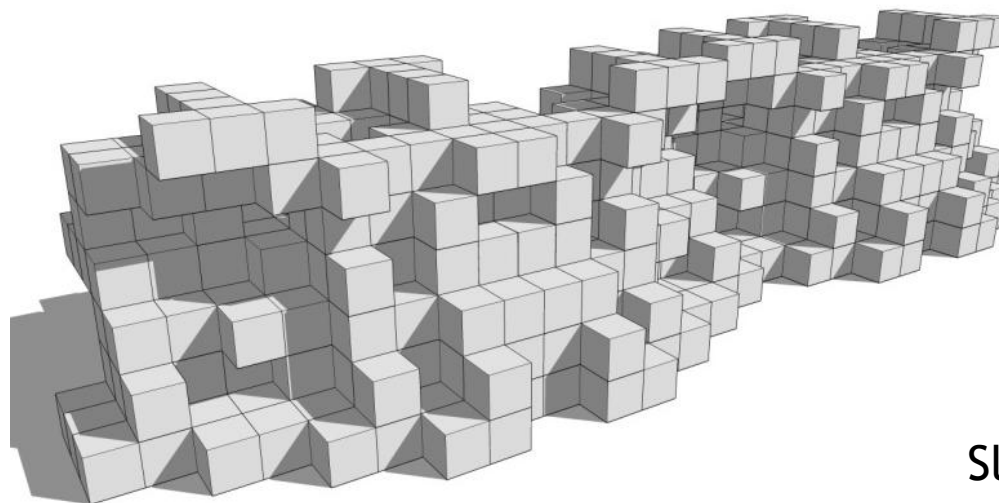

Sl. 4

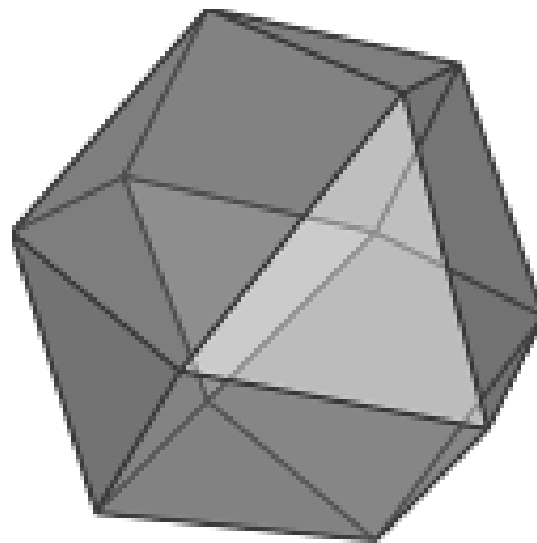

- **Kubooktaedar** - sastoji se od četrnaest pljosni (8 ravnostranih trouglova i 6 kvadrata), dvanaest roglja u kojima se sutiču trouglovi i kvadrati i **dvadesetčetiri ivice**.

# Primena heksoedra u arhitekturi

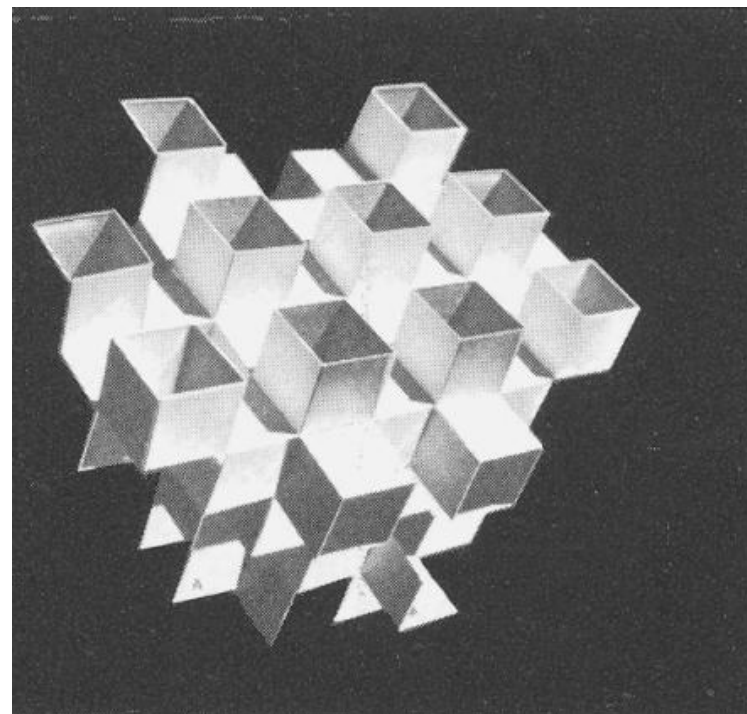
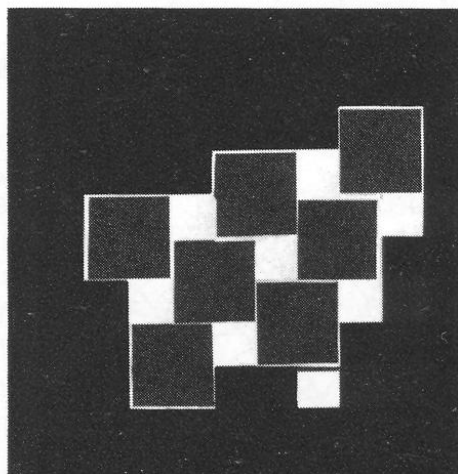
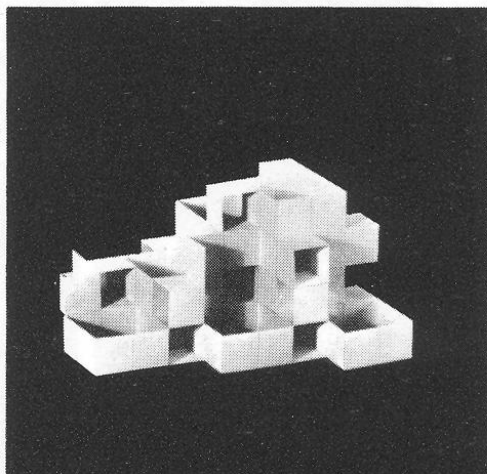
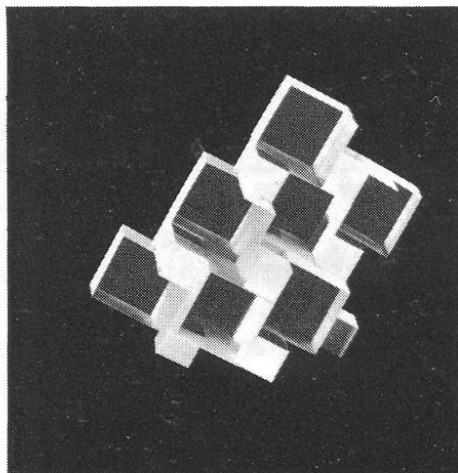
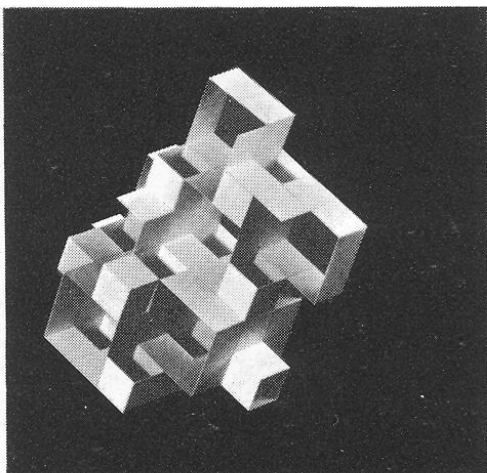



# Primena heksoedra u arhitekturi

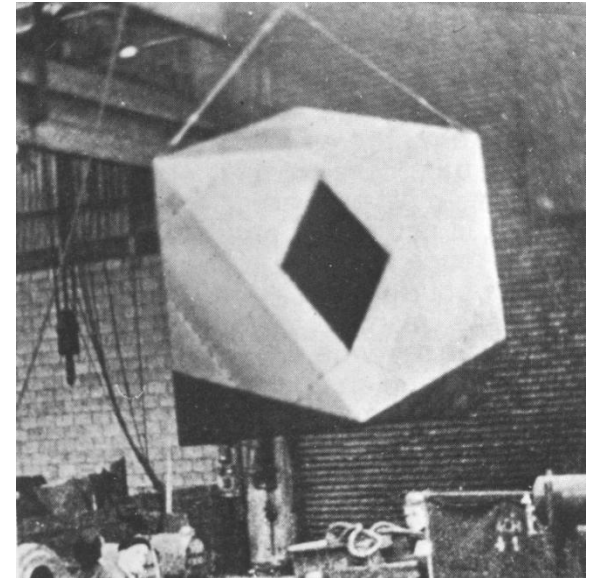
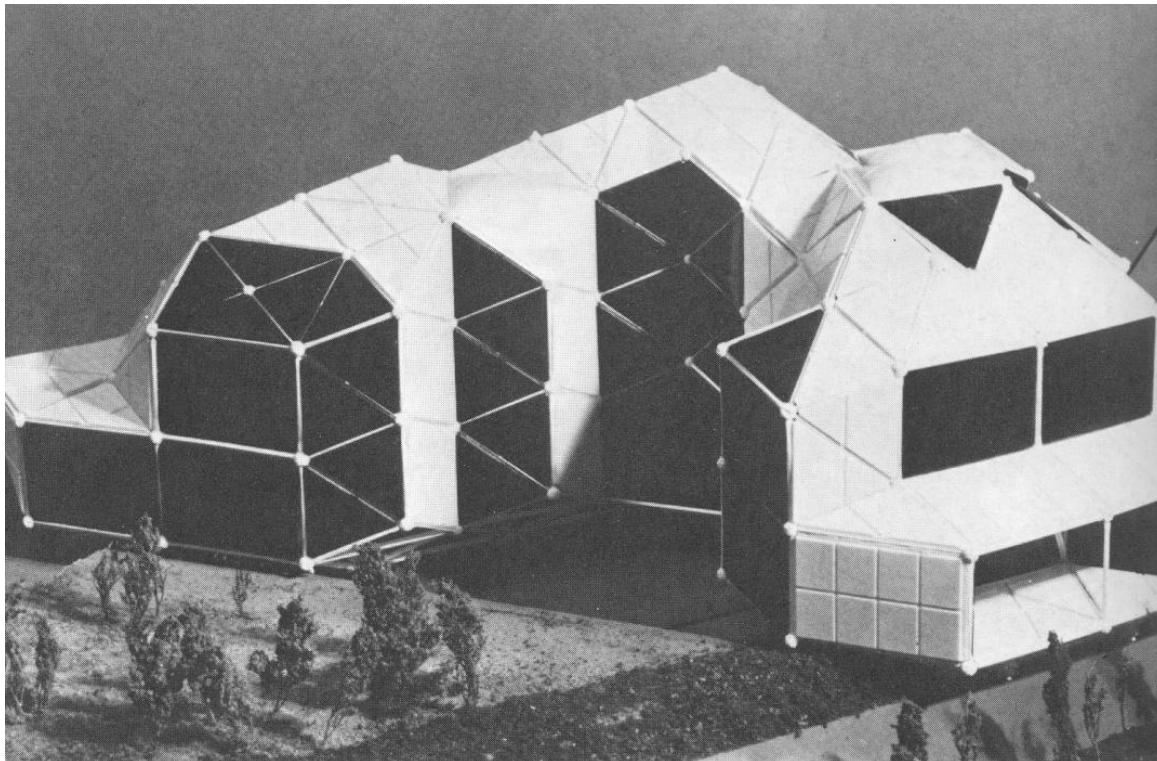

## Primena heksoedra u arhitekturi



**Habitat 67**, Montreal, Kanada, arh. Moshe Safdie, 1967.g.





## Primena heksoedra u arhitekturi

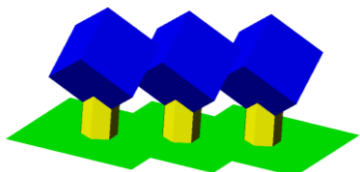

**Stambeni blok**, Helmond, Holandija, arh. Piet Blom, 1984.g



## Primena heksoedra u arhitekturi



**Cube**, Murten, Swiss Expo 2002, arh. Jean Nouvel, 2002.g.

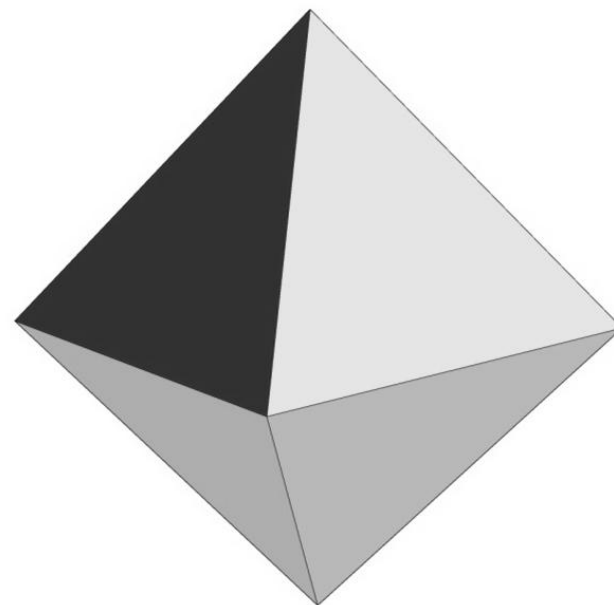

- **Oktaedar** - sastoji se od **osam pljosni** (ravnostrani trouglovi), šest roglja u kojima se susstiču četiri trougla i **osam jednakih ivica**, stranica trouglova.

# OKTAEDAR

## Karakteristične projekcije

$$a_0 = d/2, \quad a_0 = a\sqrt{2}/2$$

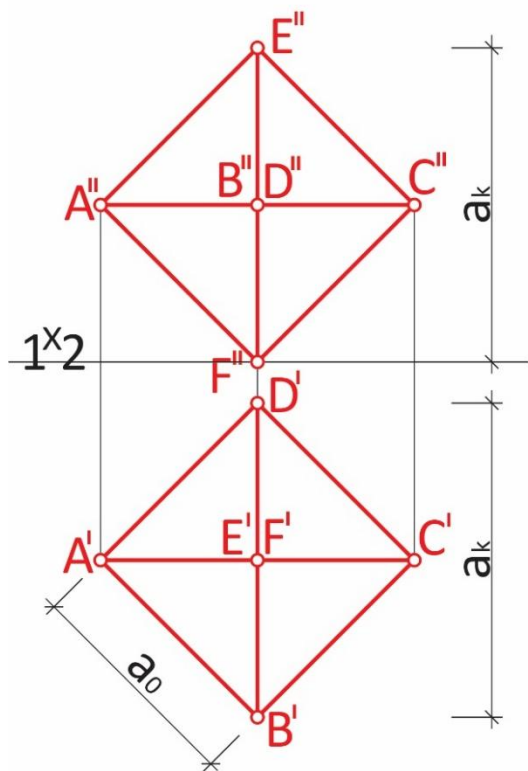
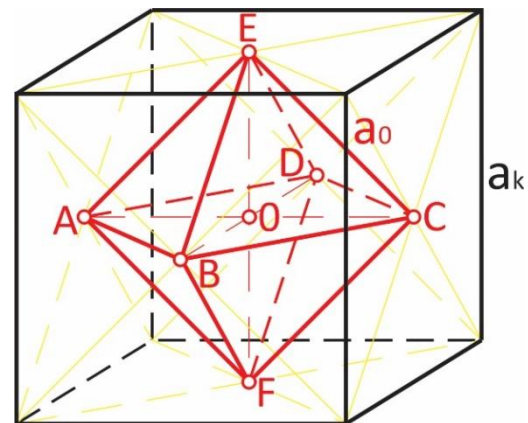

Sl. 1

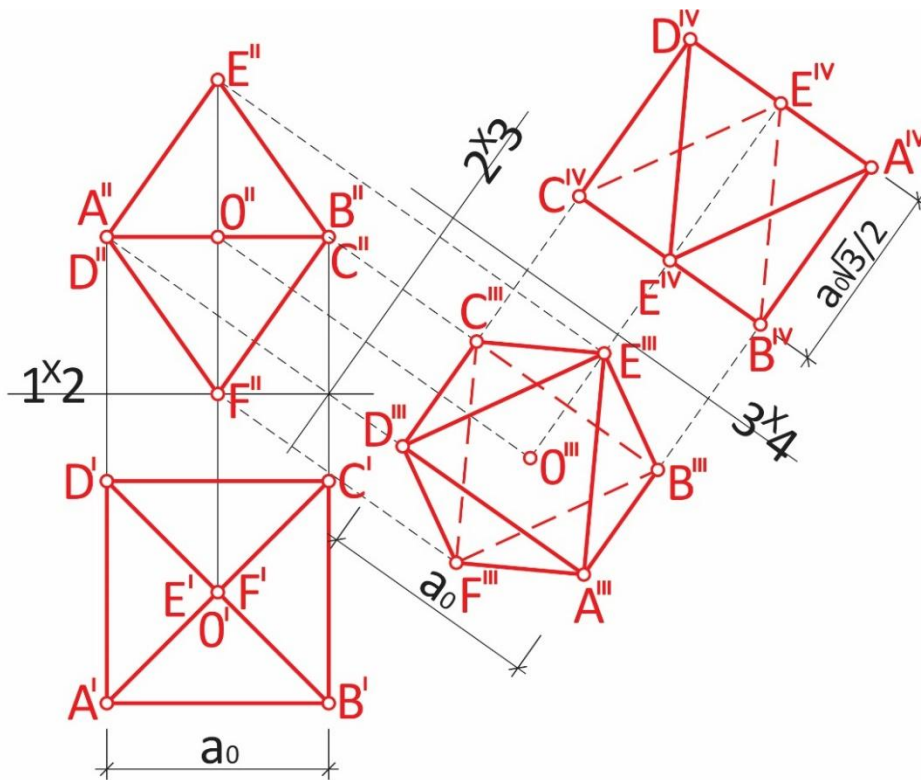

Sl. 2

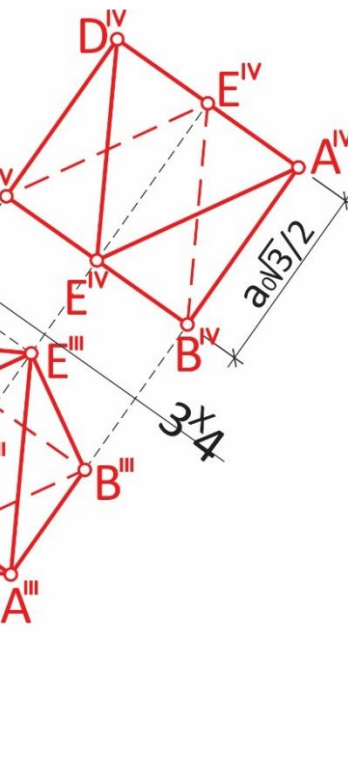

Sl. 3

# OKTAEDAR

## Ravni preseci

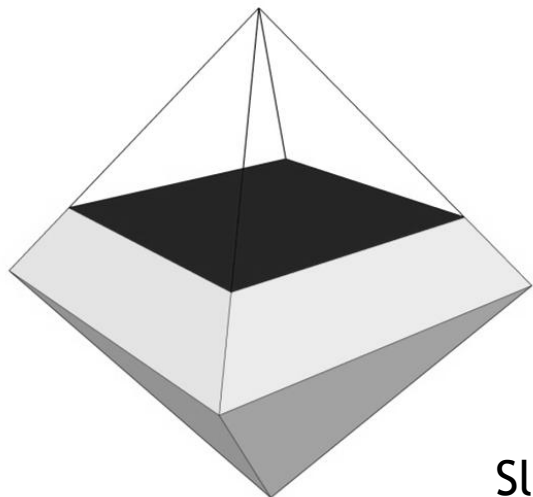

Sl. 1

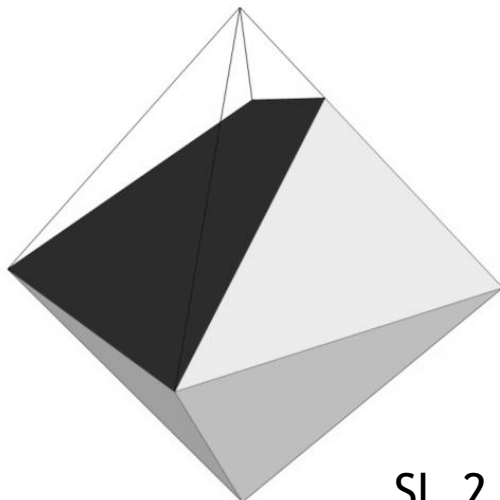

Sl. 2

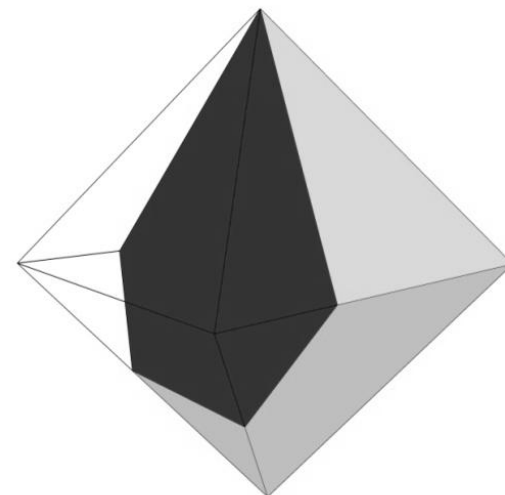

Sl. 3

## Prodori

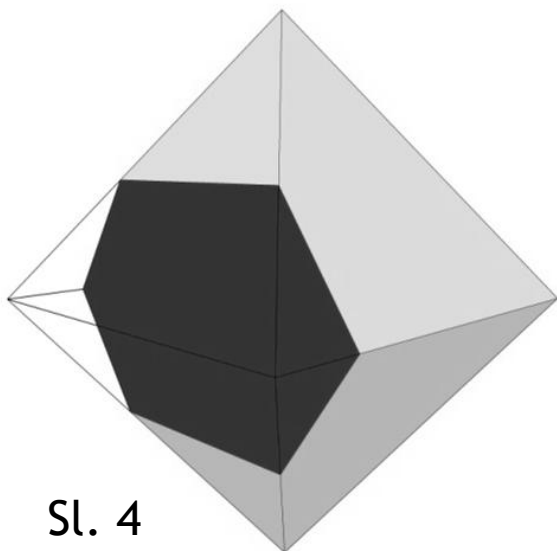

Sl. 4

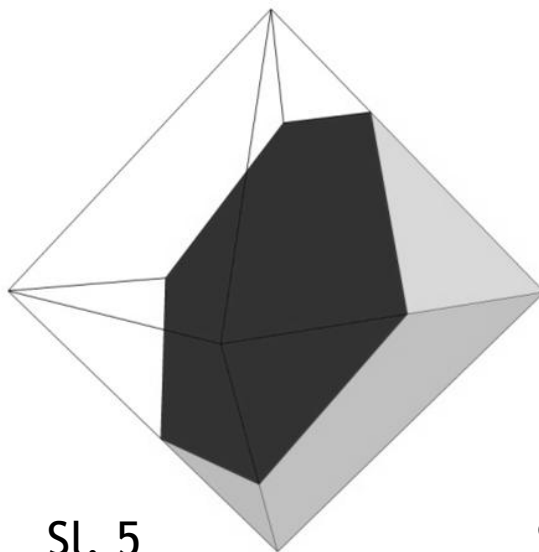

Sl. 5

Sl. 6

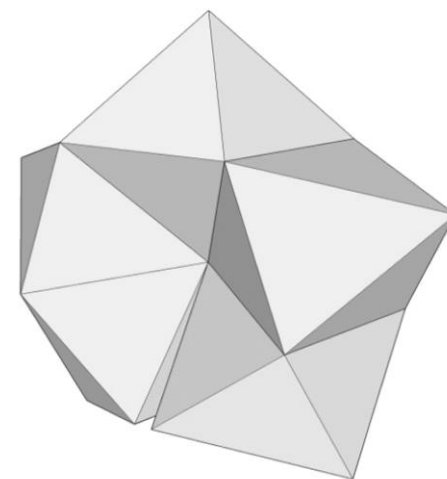

# OKTAEDAR

## Mogućnosti spajanja i primena

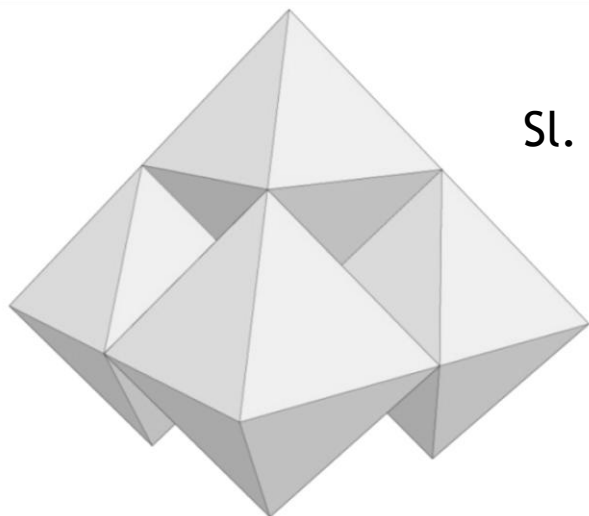

Sl. 1



Sl. 2

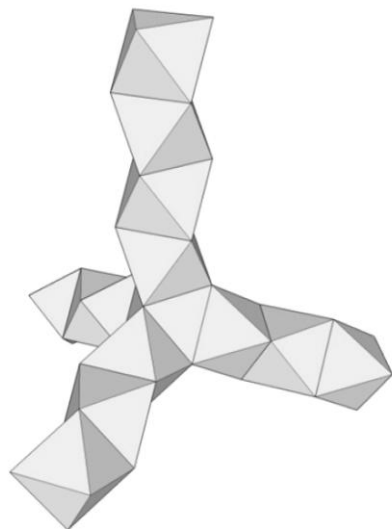

Sl. 3

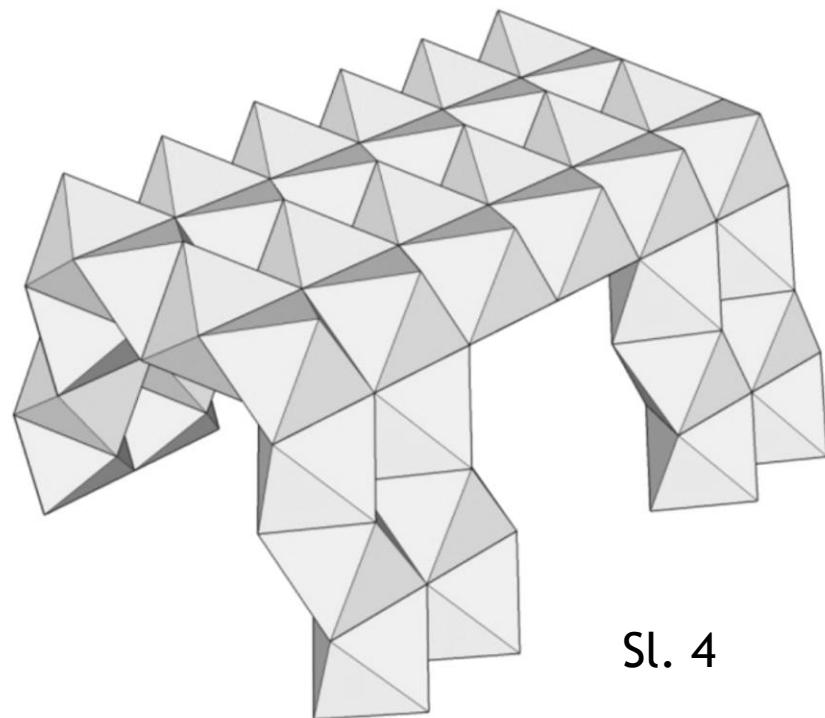

Sl. 4



- **Zasečeni oktaedar** - sastoji se od četrnaest pljosni (6 kvadrata i 8 šestouglova), dvadesetčetiri roglja u kojima se sutiču kvadrati i šestouglovi i **tridesetšest ivica**.



- **Mali rombokubooktaedar** - sastoji se od **dvadesetšest pljosni** (8 trouglova i 18 kvadrata), **dvadesetčetiri roglja** u kojima se **sutiču trouglovi i kvadrati** i **četrdesetosam ivica**.



• **Zasečeni kbooktaedar** - sastoji se od **dvadesetšest pljosni** (12 kvadrata, 8 šestouglova i 6 osmouglova), četrdesetosam roglja u kojima se sutiču kvadrati, šestouglovi i osmouglovi i **sedamdesetdve ivice**.



## Primena oktaedra u arhitekturi

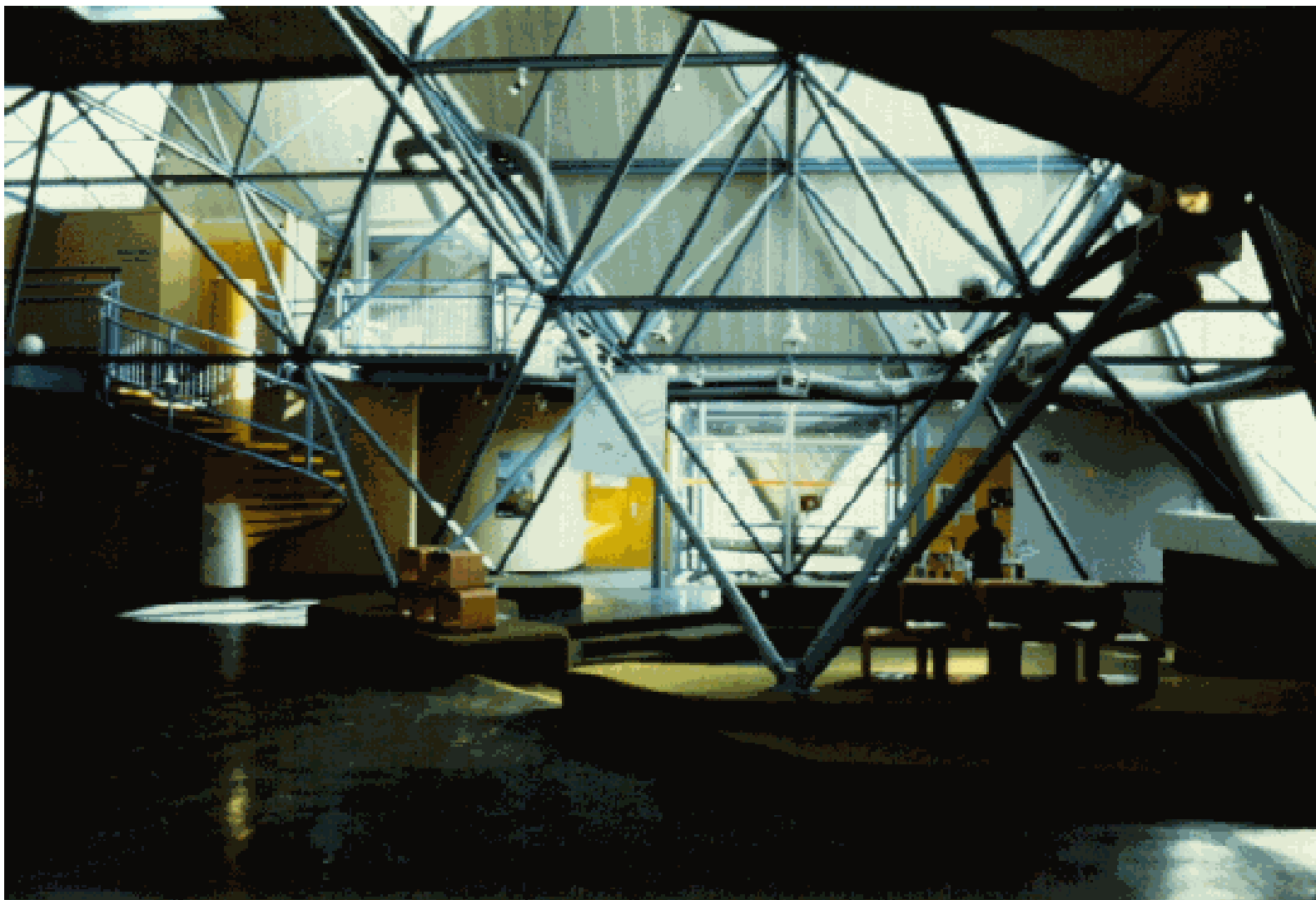

**Društveni centar Z.U.P.**, Sud a Rennes, Francuska

# Primena oktaedra u arhitekturi

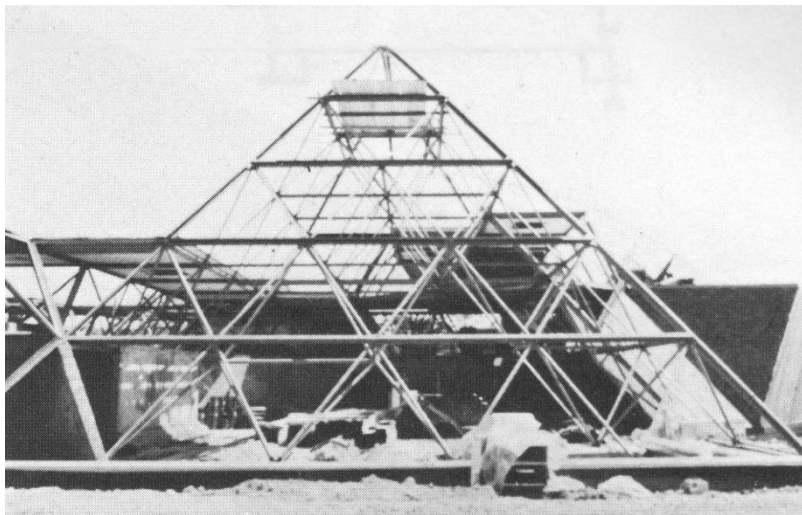

**Društveni centar Z.U.P.,**  
Sud a Rennes, Francuska

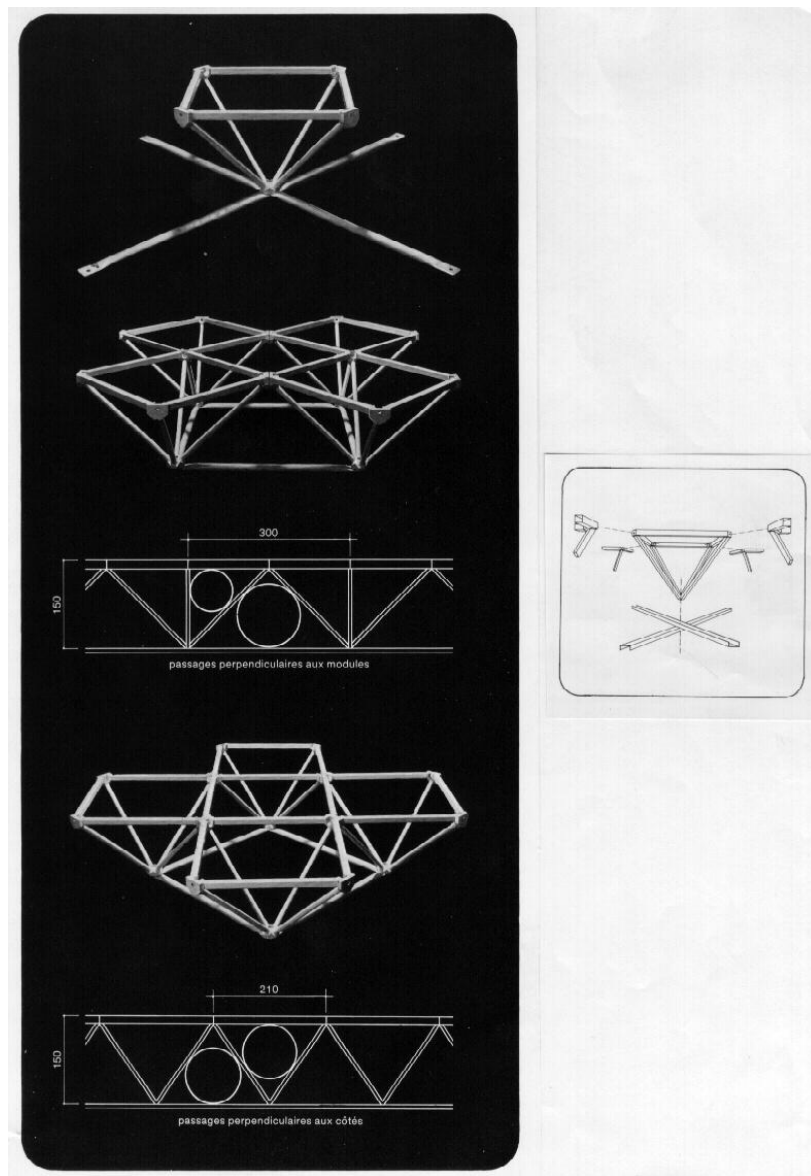

## Primena oktaedra u arhitekturi



**Hope Forest, sportski centar**, Bogota,  
Kolumbija, arh. Jorge Gamboa, 2010.g  
zasečeni oktaedar



## Primena sekundarnog oktaedra u arhitekturi

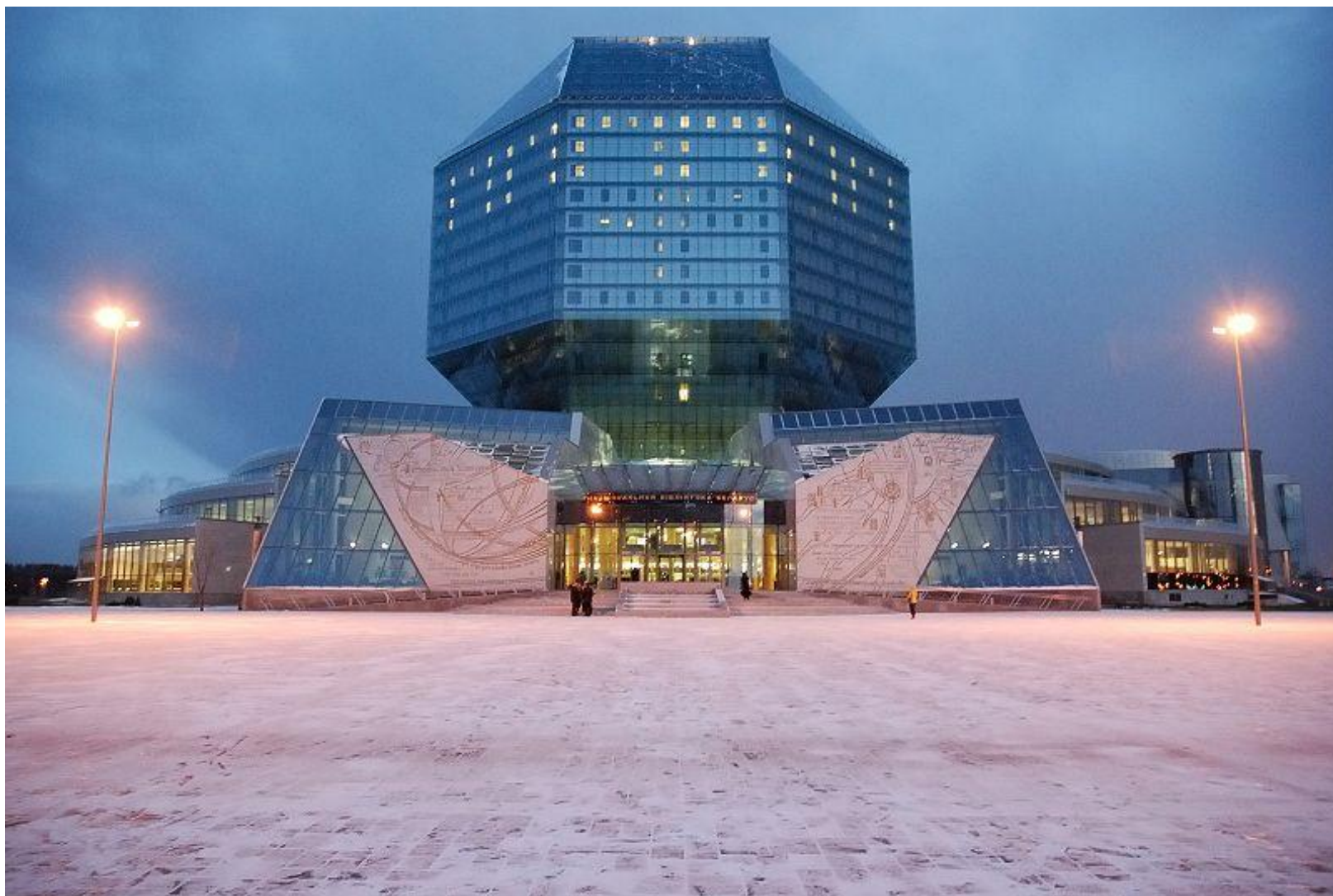

**Nacionalna biblioteka**, Minsk, Belorusija, arh. Mihail Vinogradov i Viktor Kramarenko, 2006.g, **mali rombokuboktaedar**

## Primena sekundarnog oktaedra u arhitekturi

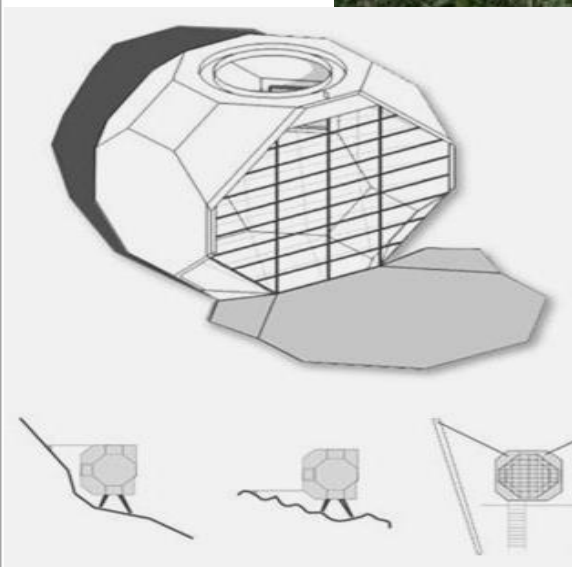

„**Poliedarsko stanovanje**“, Bogota, Kolumbija, arh. Manuel Vila,  
zasećeni kuboooktaedar

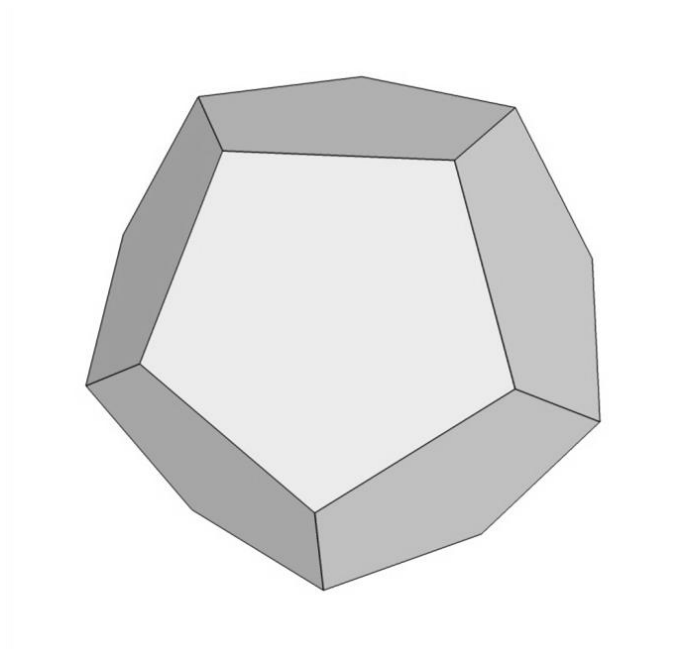

- **Pentagonalni dodekaedar** - sastoji se od **dvanaest pljosni** (pravilni petougionici), dvadeset roglja u kojima se susstiču tri petougionika i **trideset jednakih ivica**, stranica petougionika.



## Karakteristične projekcije

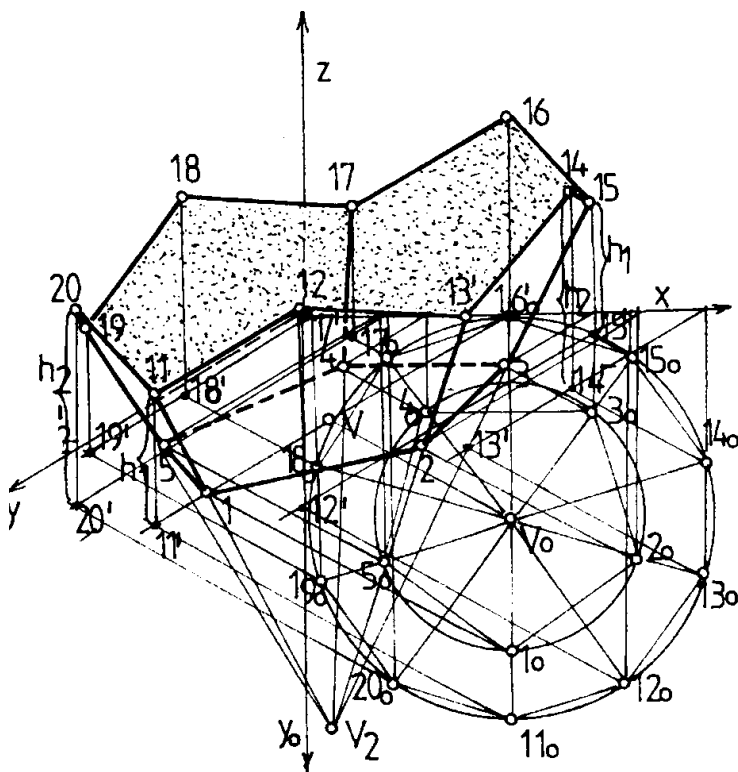

sl. 1

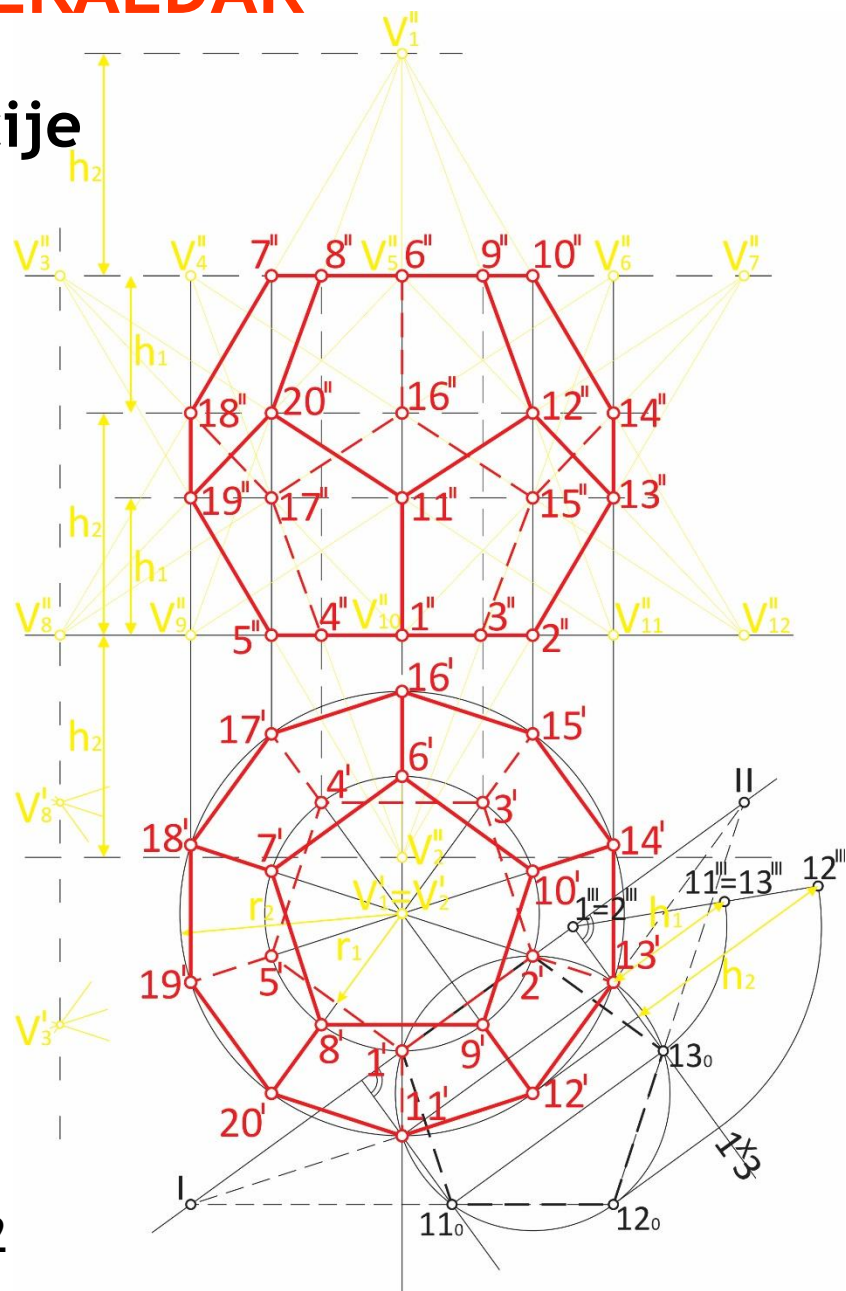

sl. 2

# PENTAGONALNI DODEKAEDAR

## Ravni preseki

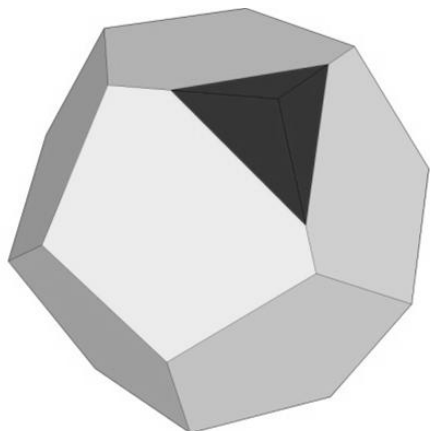

Sl. 1

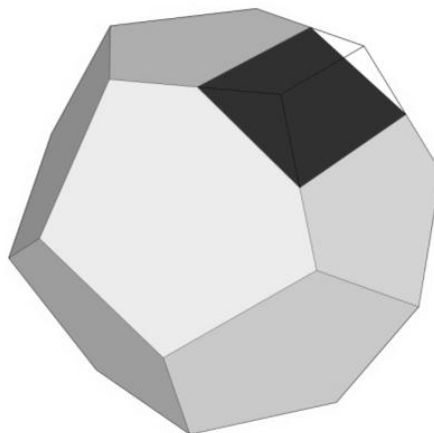

Sl. 2

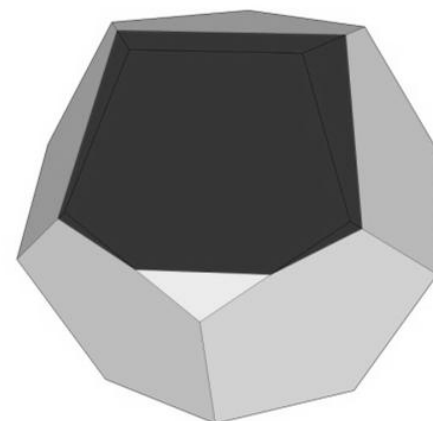

Sl. 3

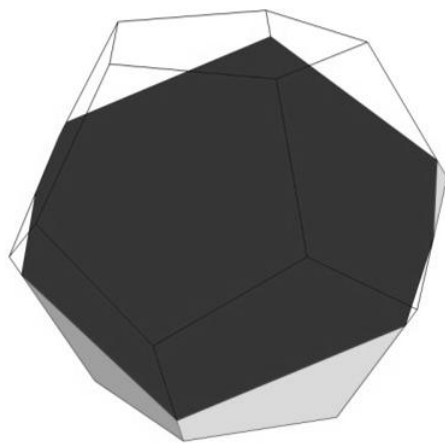

Sl. 4

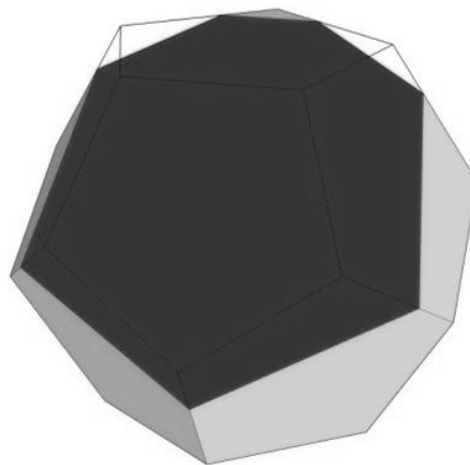

Sl. 5

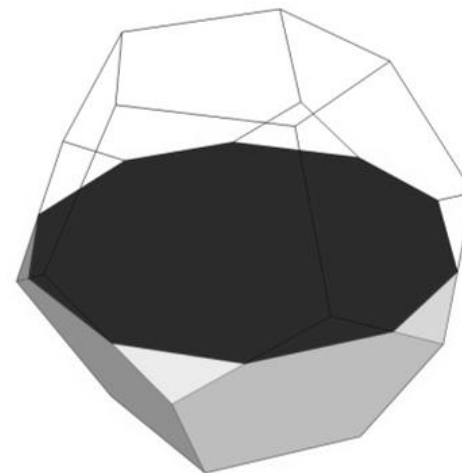

Sl. 6



# PENTAGONALNI DODEKAEDAR

## Mogućnost spajanja i primena

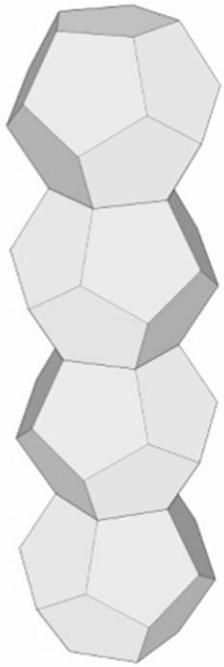

Sl. 1

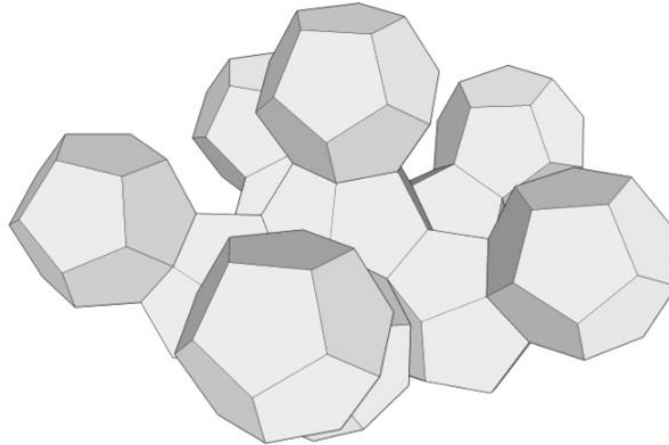

Sl. 2

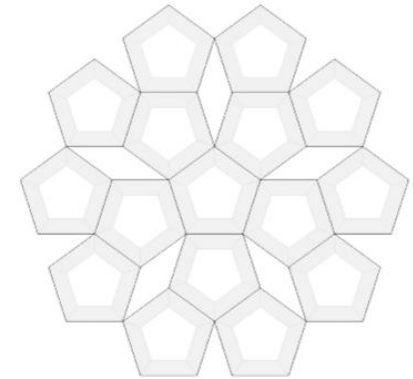

Sl. 3

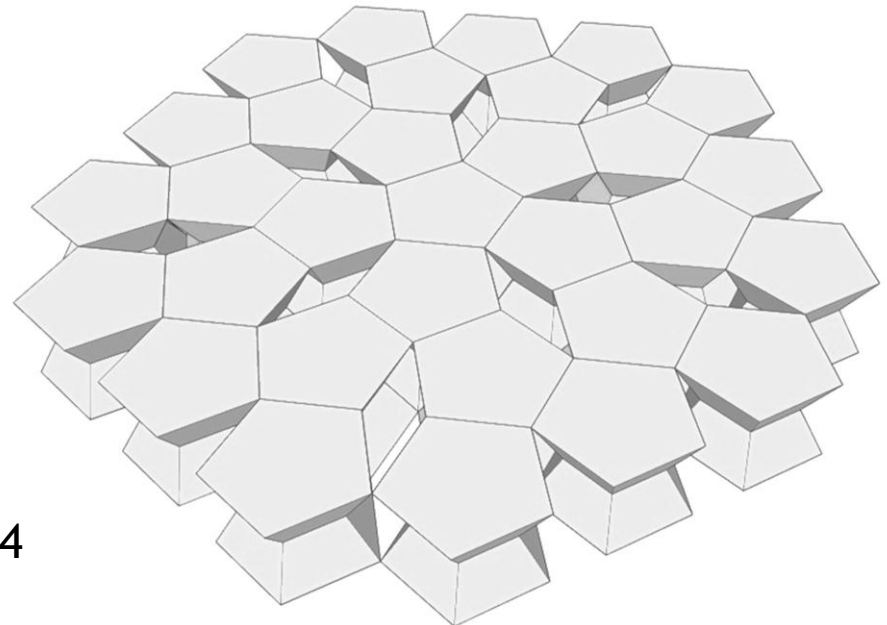

Sl. 4

# Primena pentagonalnog dodekaedra u arhitekturi

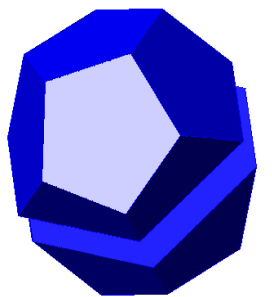
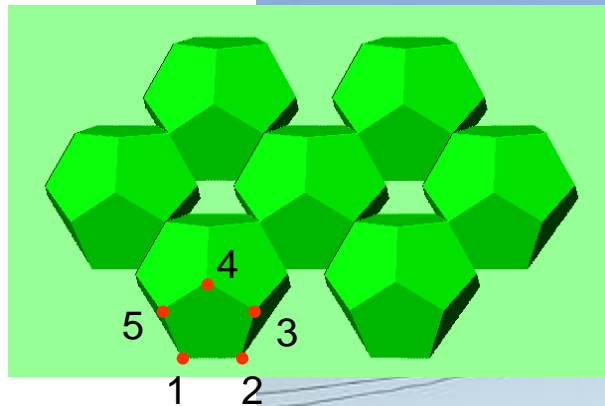

**Stambena zona, Ramot Housing**, Jerusalem, Israel, arh. Zvi Hecker, 1971-1985.g.

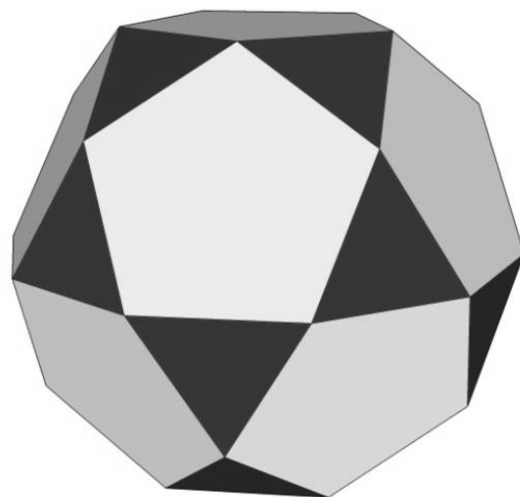
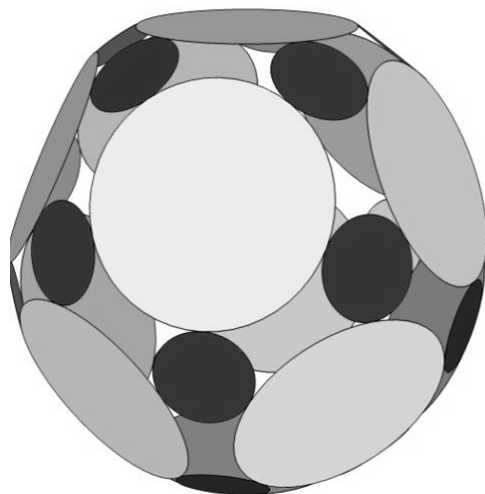

- **Ikosododekaedar** - sastoji se od **tridesetdve pljosni** (20 trouglova i 12 petouglova), trideset roglja u kojima se sutiču trouglovi i petouglovi i **šestdeset ivica**.

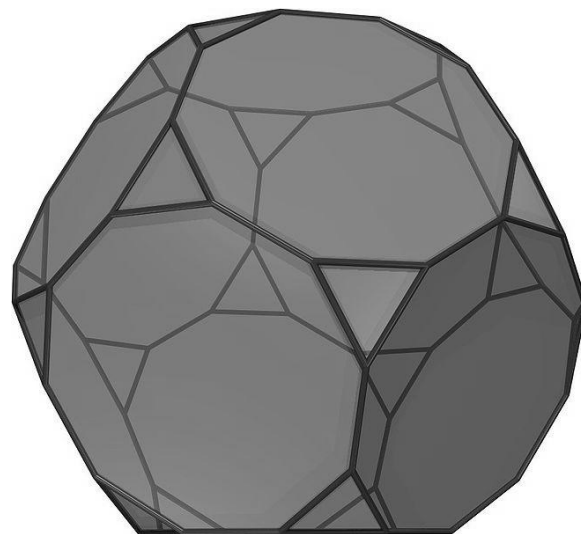

- **Zasečeni dodekaedar** - sastoji se od **tridesetdve pljosni** (20 trouglova i 12 desetouglova), šestdeset rogla u kojima se sutiču trouglovi i desetouglovi i **devedeset ivica**.

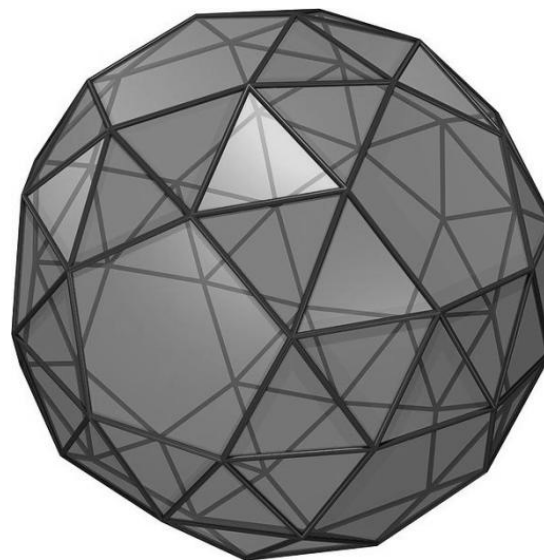

- **Razdvojeni (snub) dodekaedar** -  
sastoji se od **devedesetdve pljosni** (80  
trouglova i 12 petouglova), **šestdeset**  
roglja u kojima se sutiču trouglovi i  
petouglovi i **stopedeset ivica**.

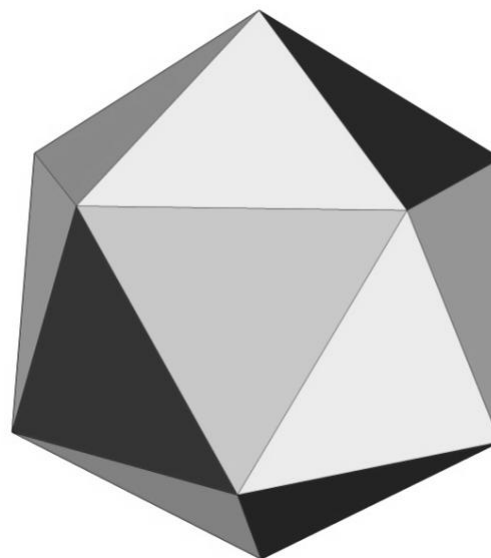

- **Ikosaedar** - sastoji se od **dvadeset pljosni** (ravnostrani trouglovi), dvanaest roglja u kojima se susstiču pet trouglova i **trideset jednakih ivica**, stranica ravnostranih trouglova.



# IKOSAEDAR

## Karakteristične projekcije

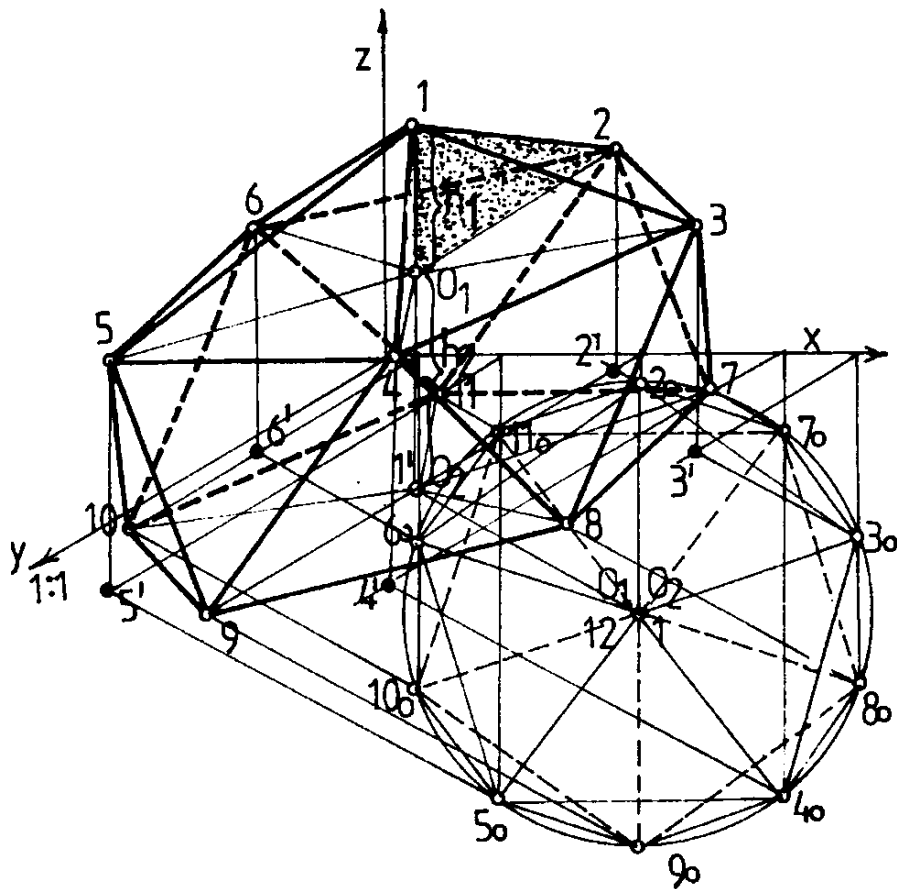

Sl.1

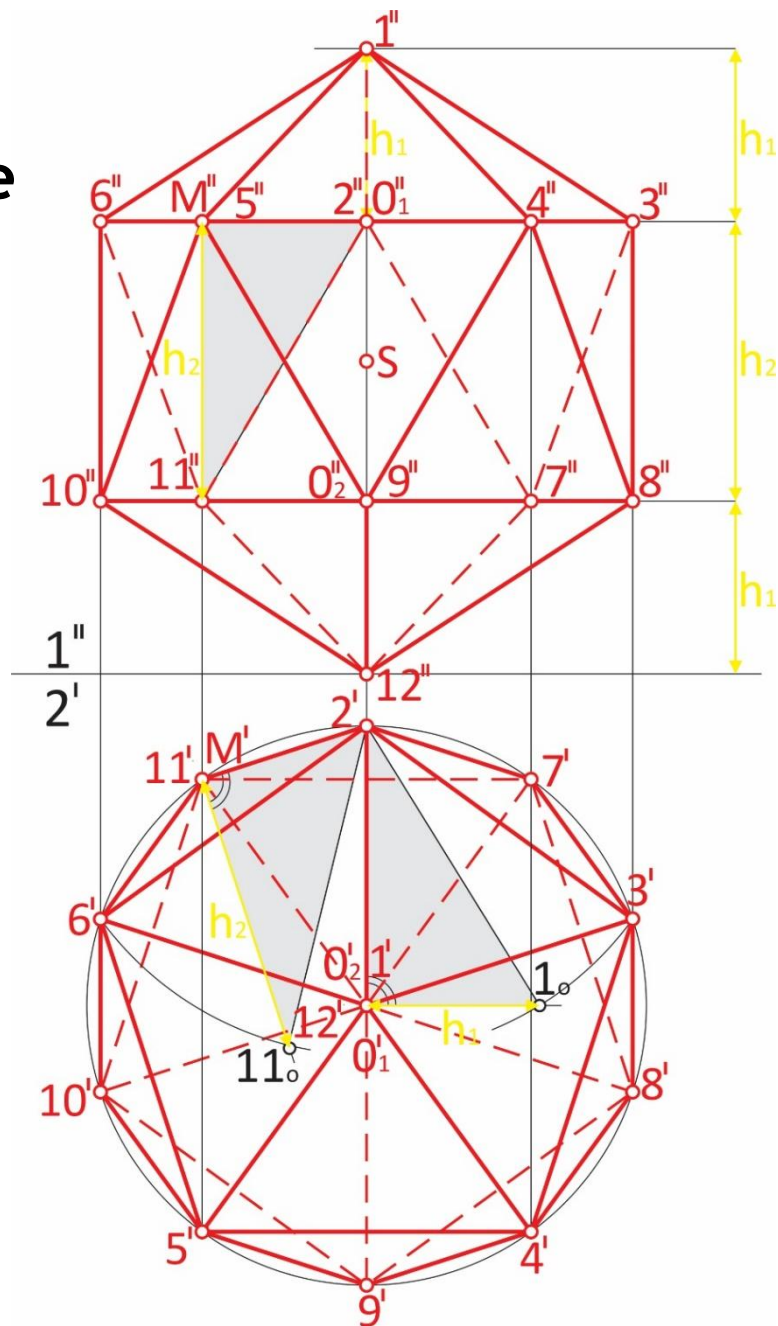

Sl.2



# IKOSAEDAR

## Ravni preseki

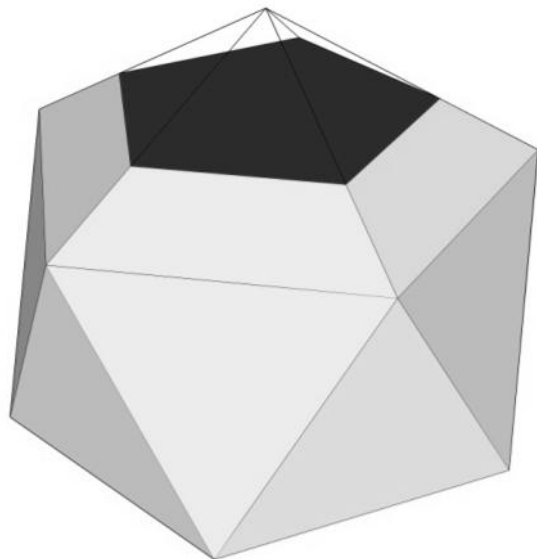

Sl. 1

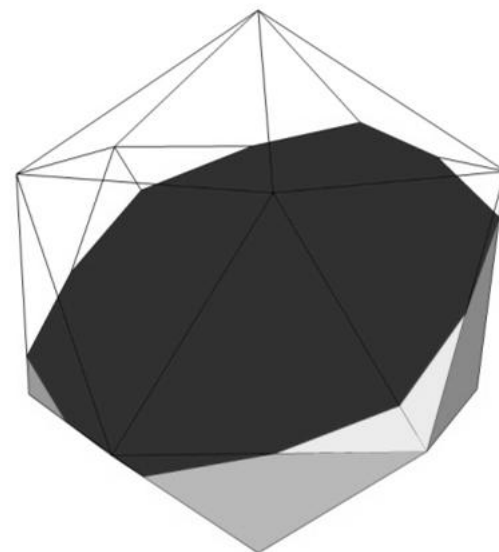

Sl. 2

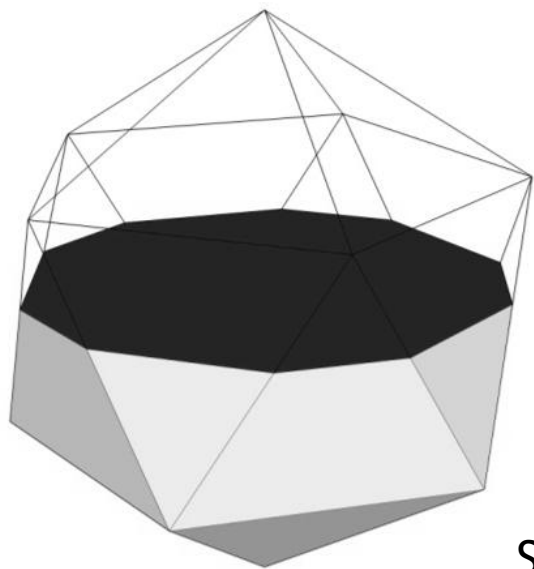

Sl. 3

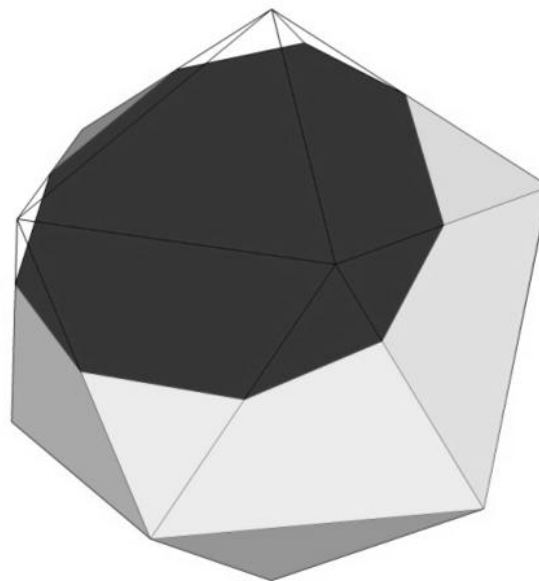

Sl. 4

## Mogućnost spajanja i primena

aksonometrija

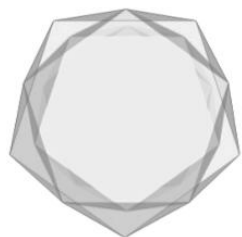
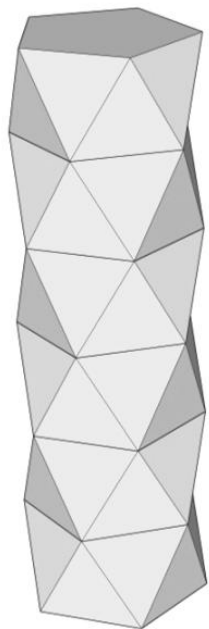

Sl. 1

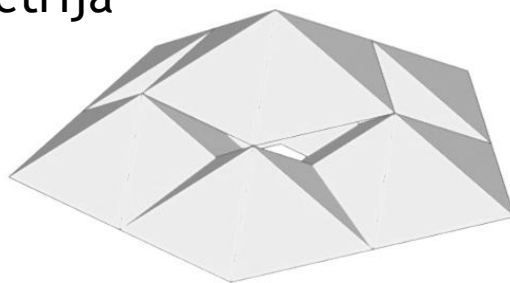

Sl. 2

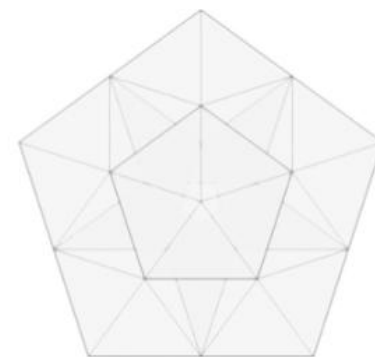

osnova

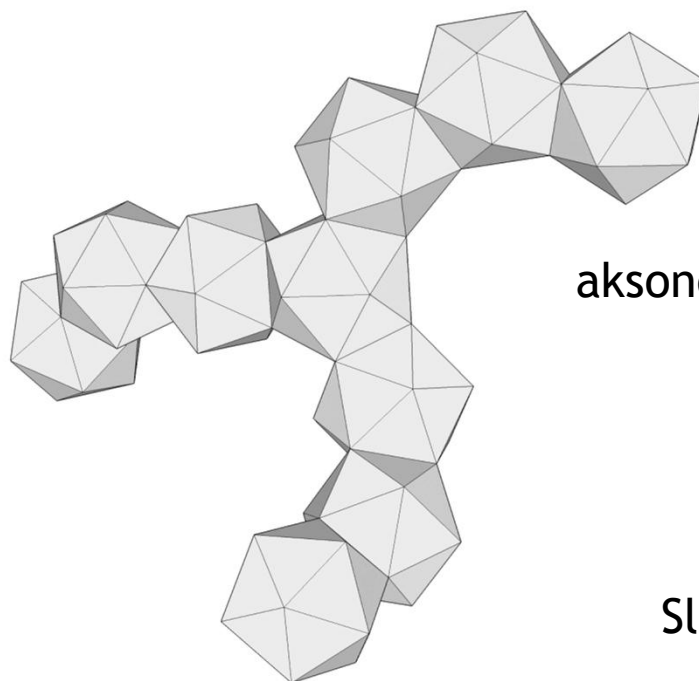

aksonometrija

Sl. 3

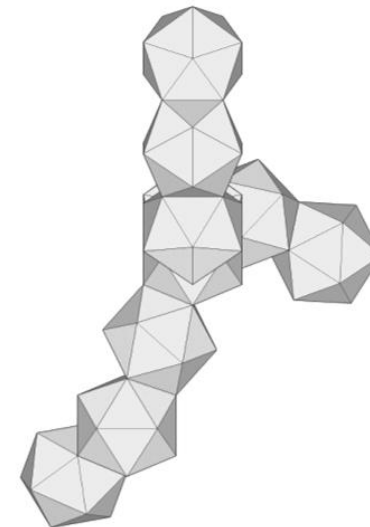

osnova

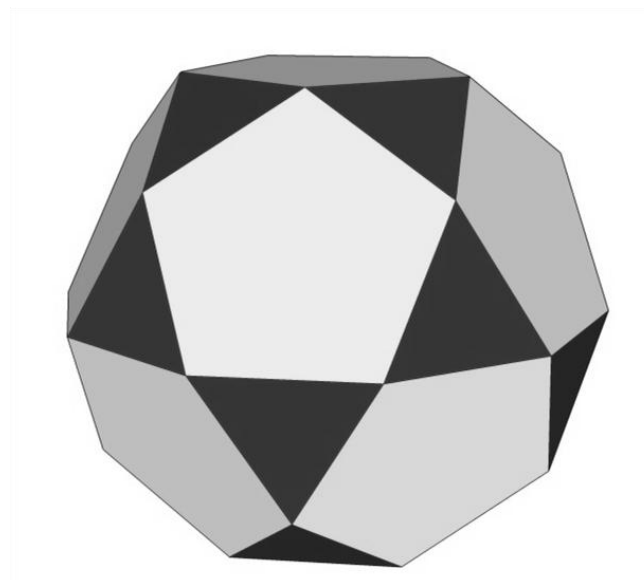

- **Ikosododekaedar** – sastoji se od **tridesetdve pljosni** (20 trouglova i 12 petouglova), trideset roglja u kojima se sutiču trouglovi i petouglovi i **šestdeset ivica**.

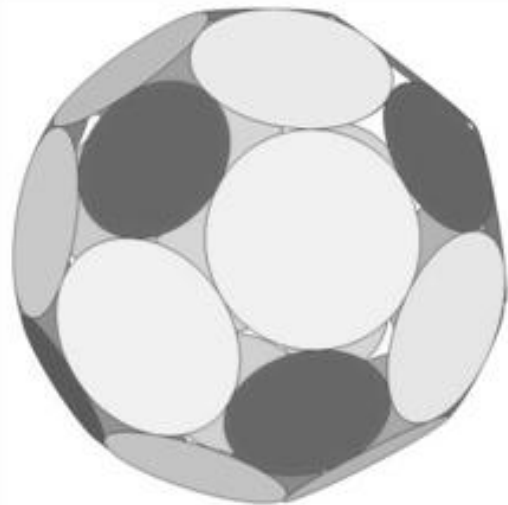

- **Zasečeni ikosaedar** - sastoji se od **tridesetdve pljosni** (12 petouglova i 20 šestouglova), šestdeset roglja u kojima se sutiču petouglovi i šestouglovi i **devedeset ivica**.

## Mogućnost spajanja i primena

aksonometrija

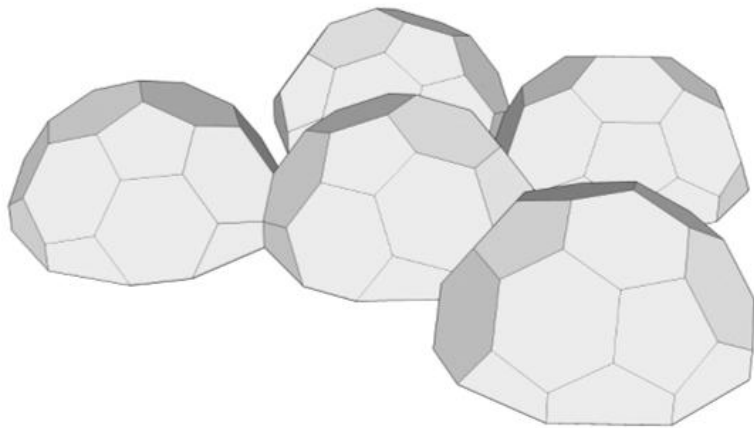

aksonometrija

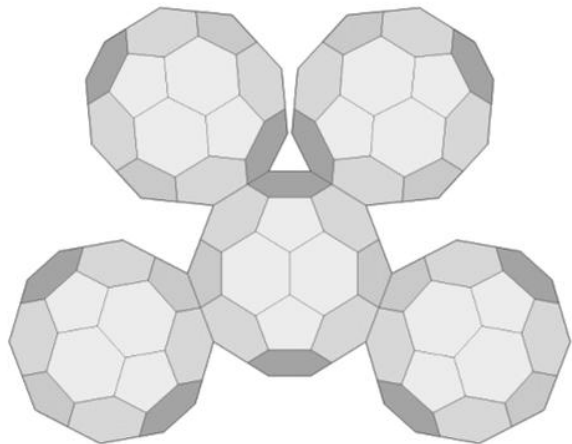
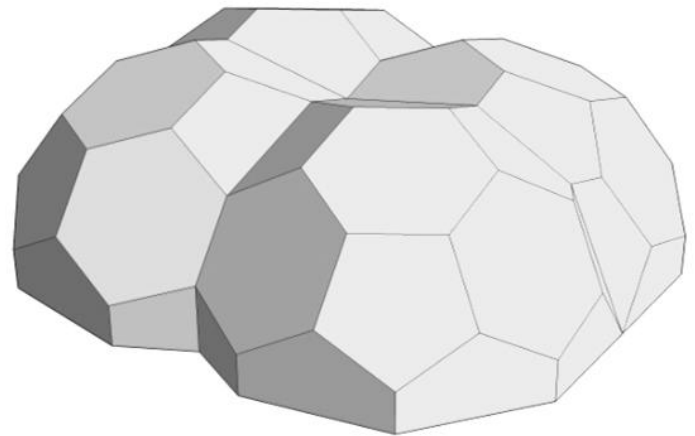

osnova

Sl.1

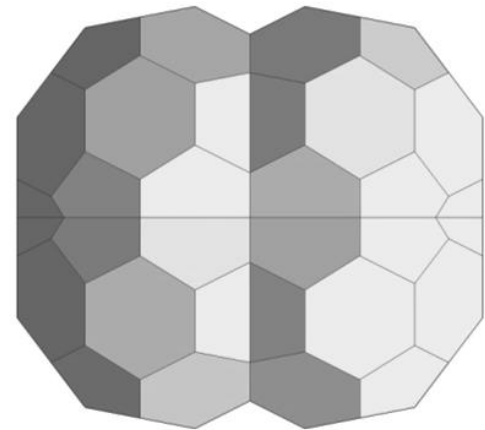

Sl.2

osnova





**IKOSAEDAR**

**Mogućnost spajanja i primena**



## Primena ikosaedra u arhitekturi



"**ICOS selo Inc,**" arh. Jill Fehrenbacher, 2005.g

## Primena sekundarnog ikosaedra u arhitekturi

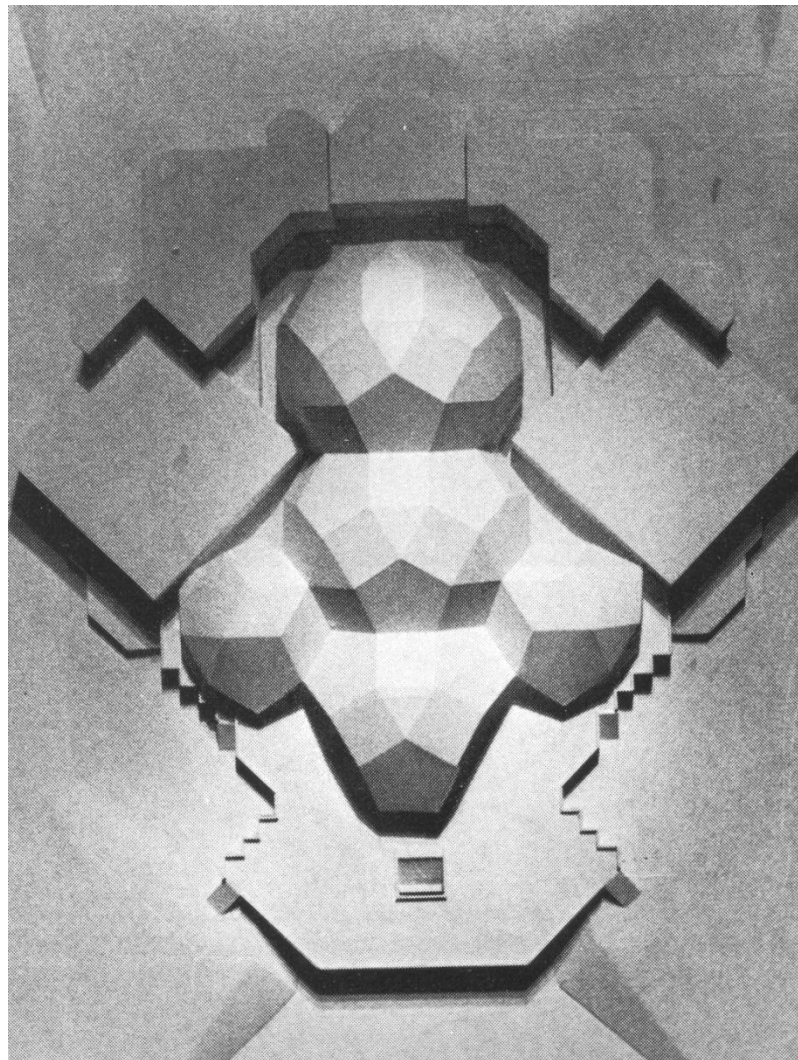
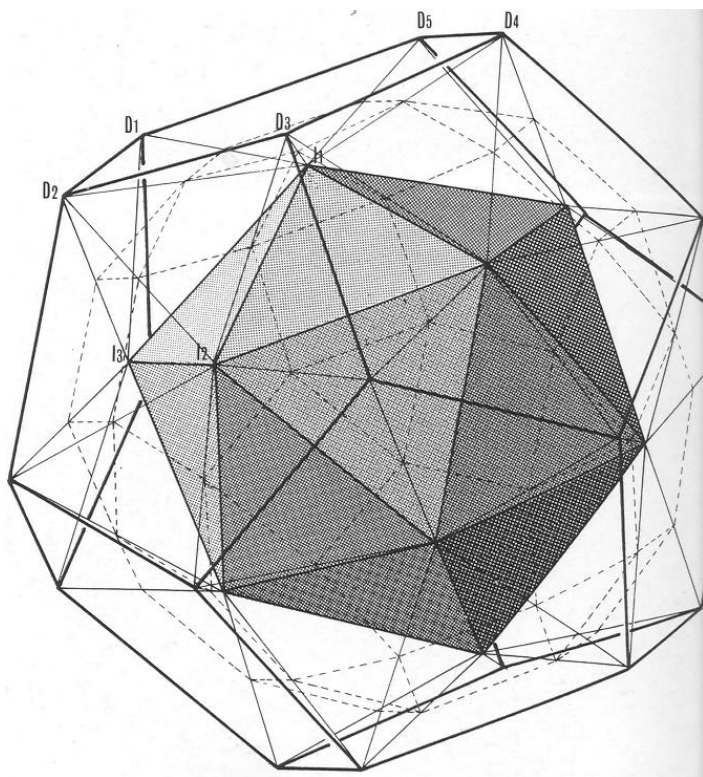

**Projekat opere**, Sofia, Bugarska, arh. Ivan Štraus i Halid Muhasilović, 1973.g, **romboikosododekaedar**



## Primena sekundarnog ikosaedra u arhitekturi



Barrier kuća,  
zasečeni  
ikosaedar





“Čuperak”, selo Kvivik, Farska Ostrva, Danska, zasečeni ikosaedar

## POLIEDARSKE POVRŠI

- **pravilni poliedri (platonova i arhimedova tela)**
- **piramide**
- **prizme**

## PRAVILNI POLIEDRI

- **PLATONOVA TELA - 5**
- **ARHIMEDOVA TELA - 13**

## PLATONOVA TELA

- **Tetraedar**
- **Heksaedar (kocka)**
- **Oktaedar**
- **Pentagonalni dodekaedar**
- **Ikosaedar**

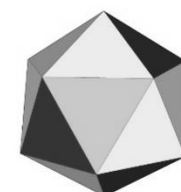
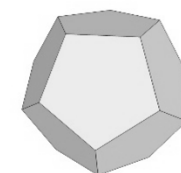
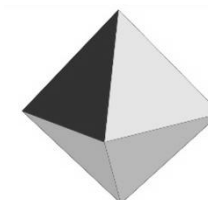
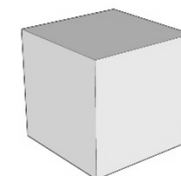
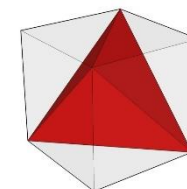



# Studentski grafički radovi

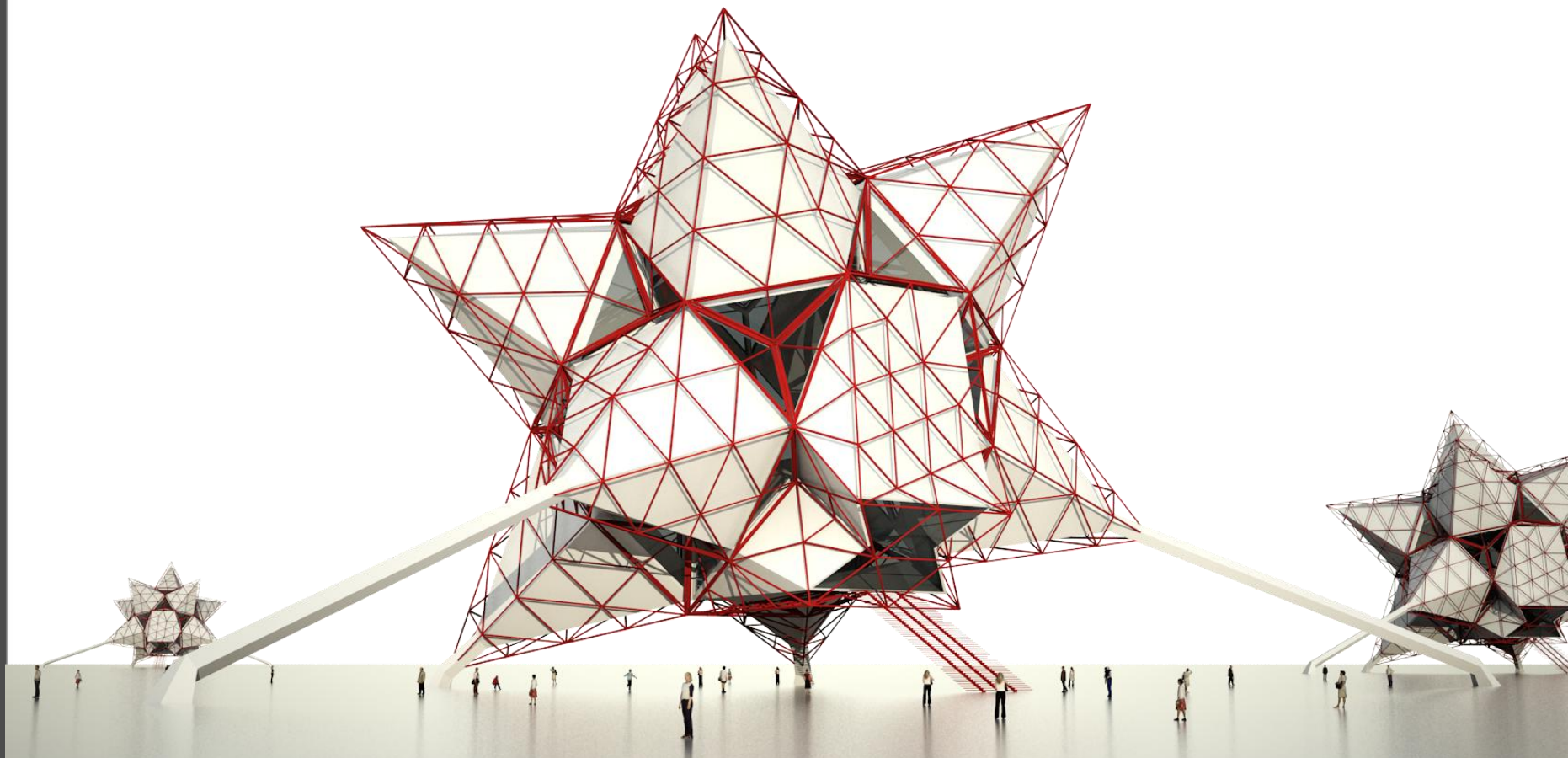

Tamara Manojlović, grafički rad, student, generacija 2009/10

# Primena sekundarnog ikosaedra u arhitekturi

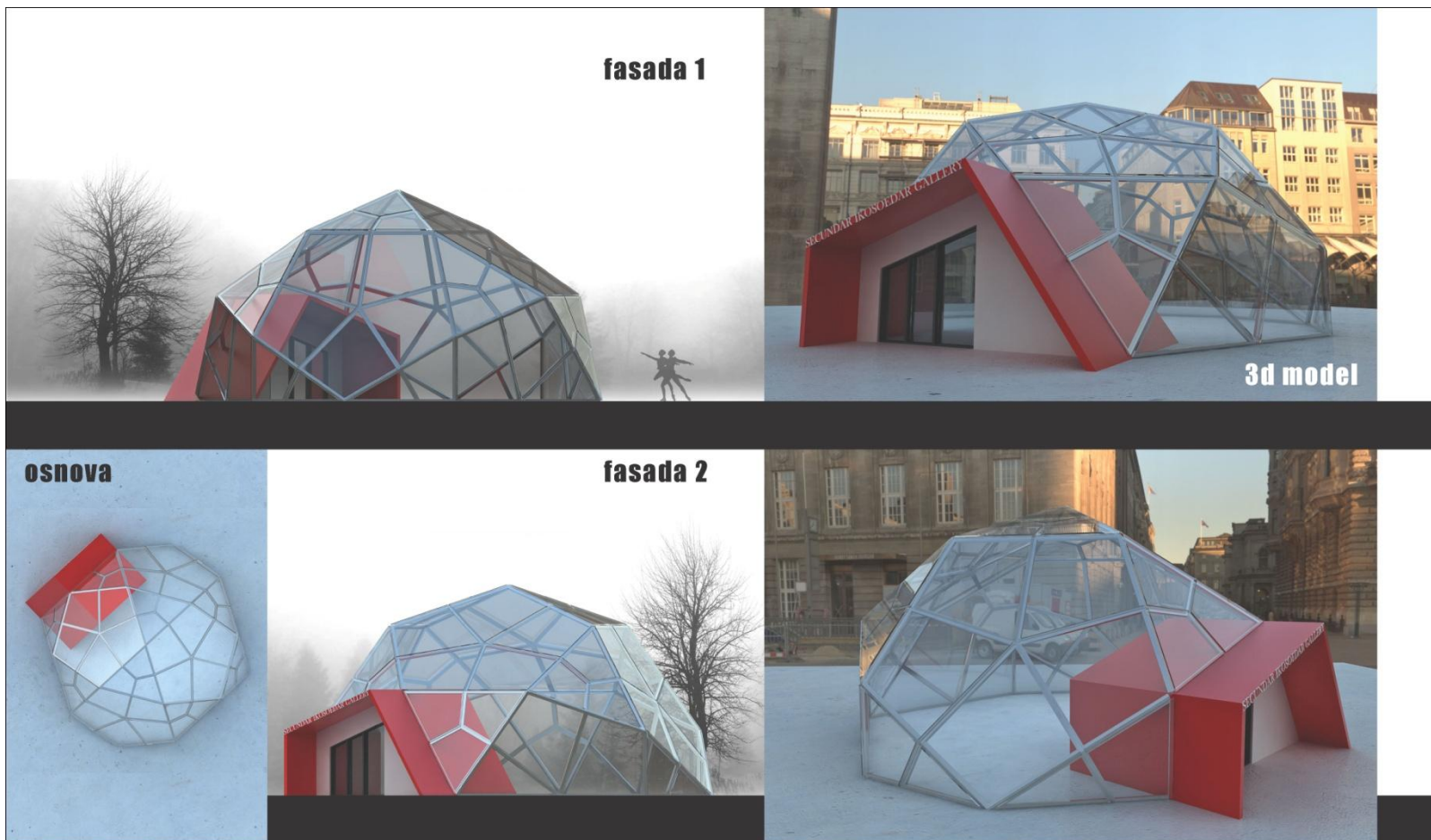



# Primena sekundarnog ikosaedra u arhitekturi

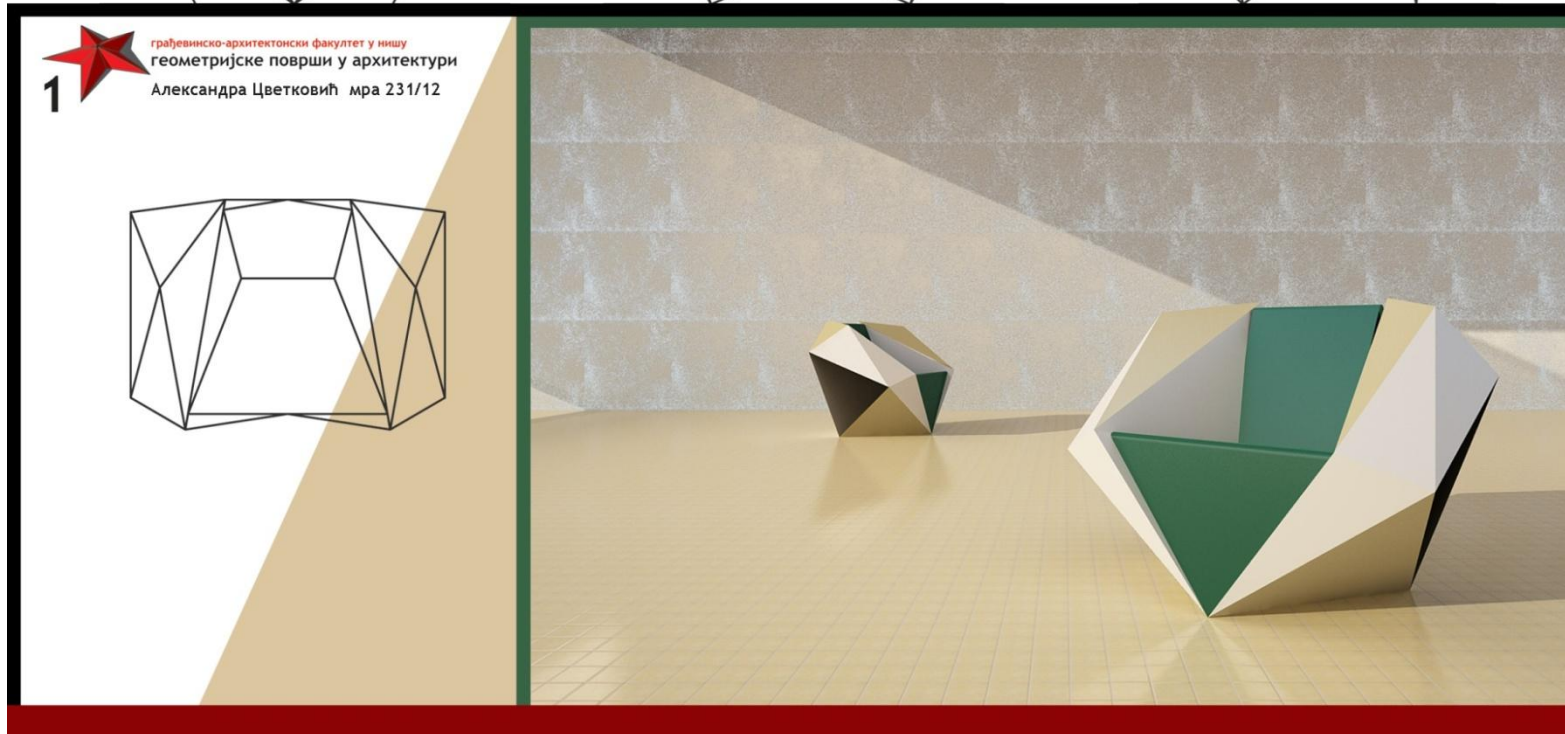
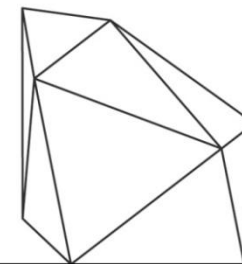
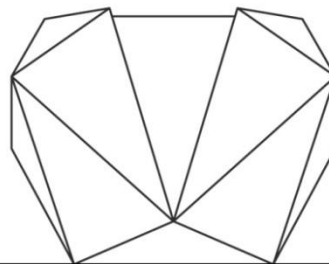
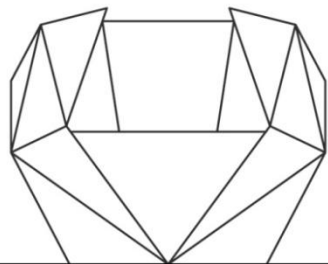

Aleksandra Cvetkovic, GPA, grafički rad, student generacija 2012/13

# Primena ikosaedra u arhitekturi

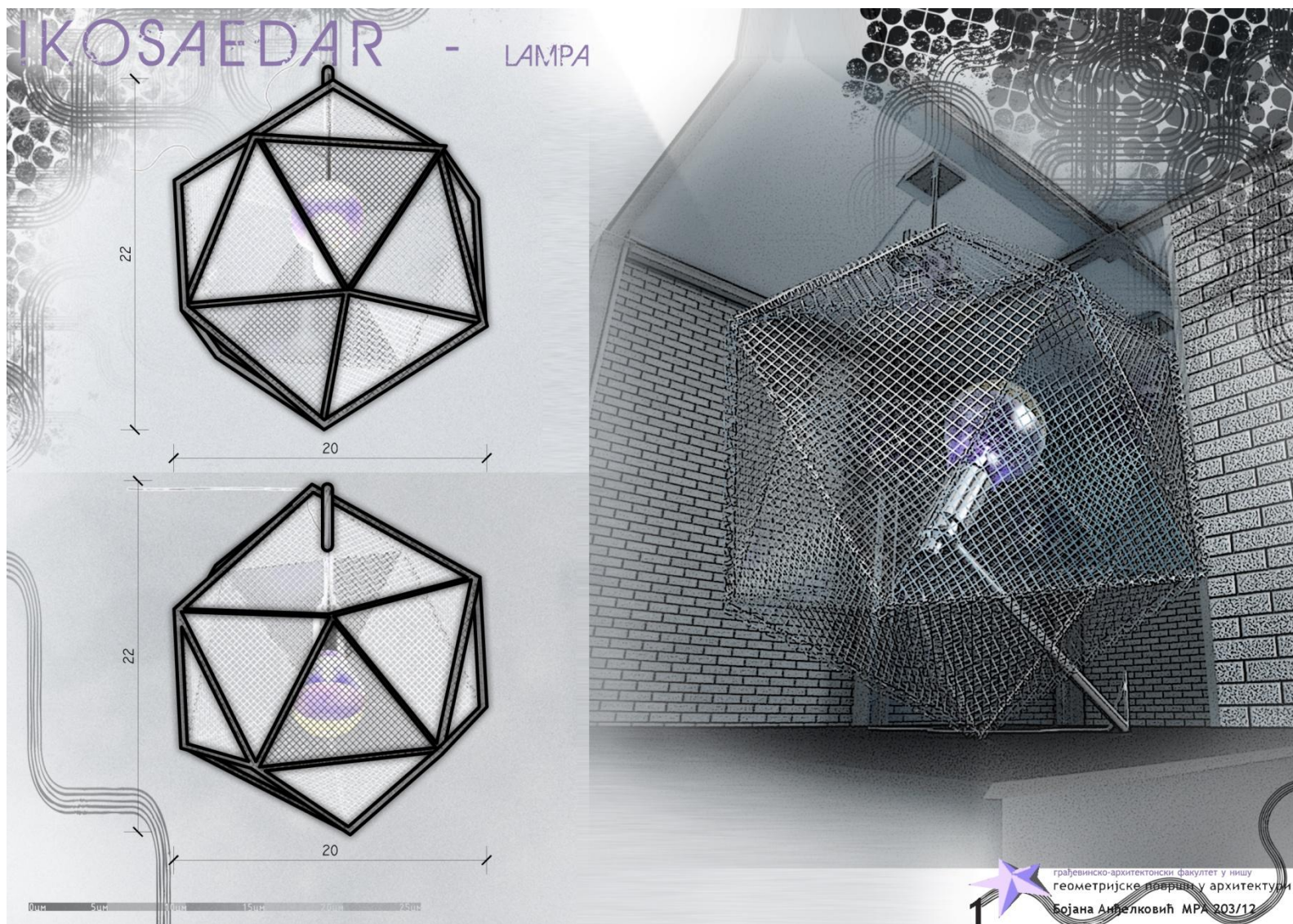

Bojana Anđelković, GPA, grafički rad, student generacija 2012/13



# Primena ikosaedra u arhitekturi

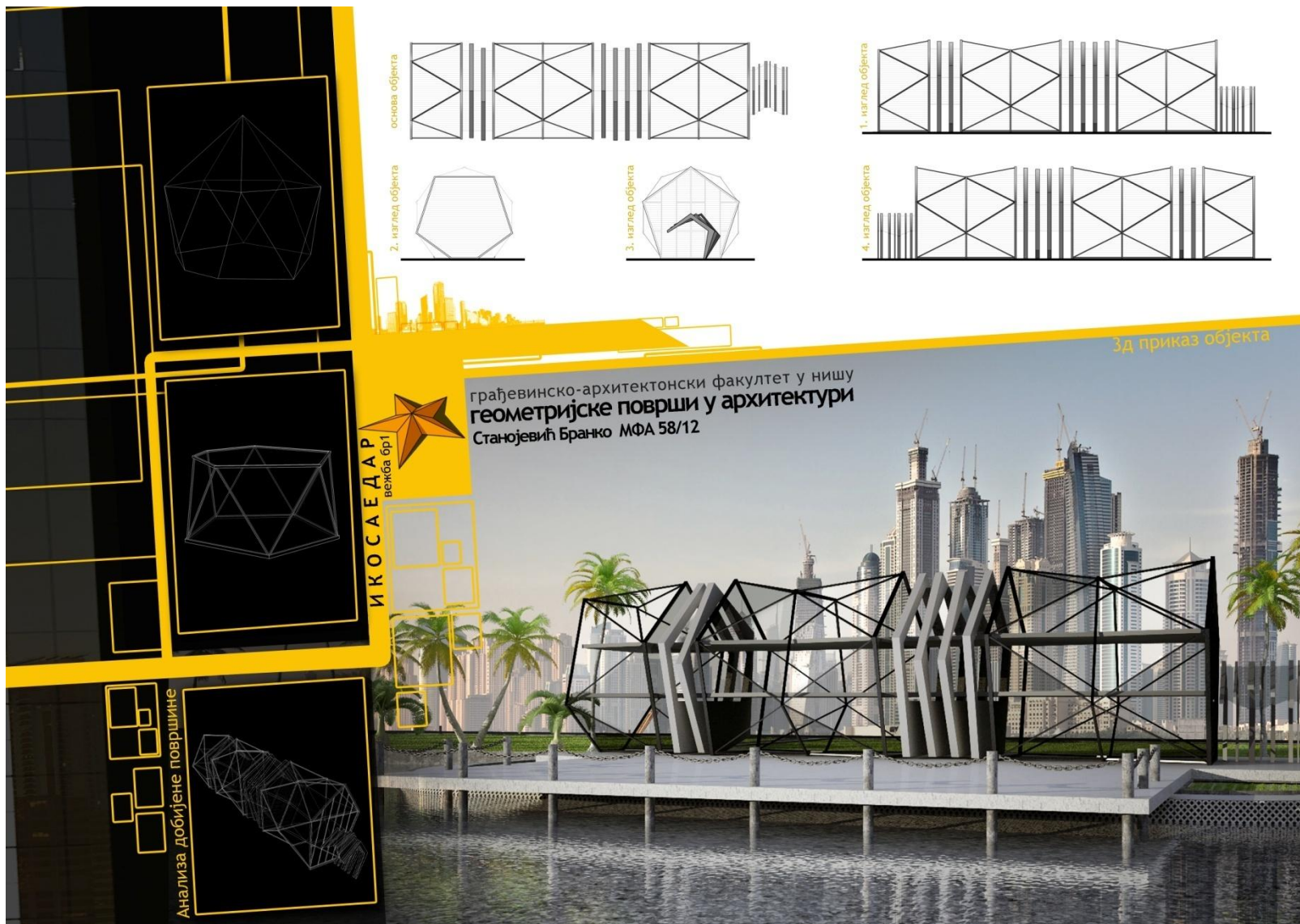

Branko Stanojević, GPA, grafički rad, student generacija 2012/13

# Primena ikosaedra u arhitekturi

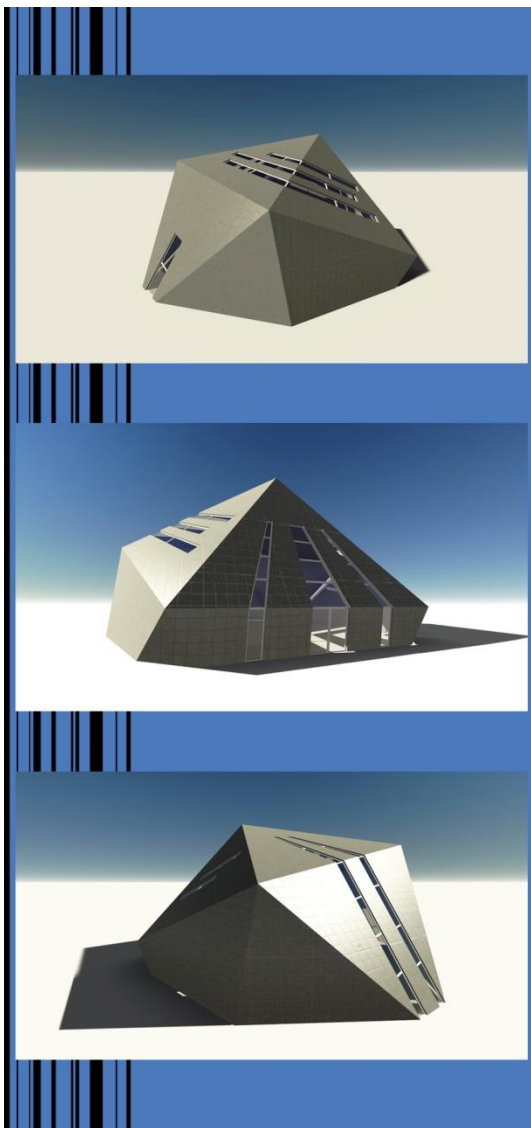

RAZMERNIK 0 — 1 0

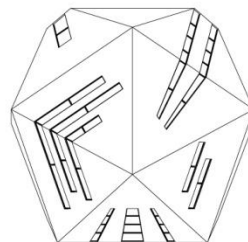

OSNOVA

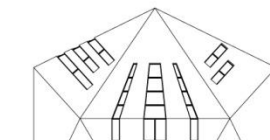

IZGLED 1

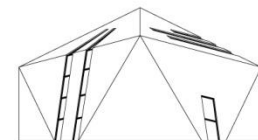

IZGLED 2

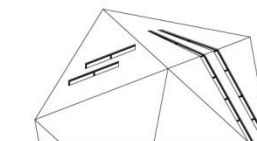

IZGLED 3

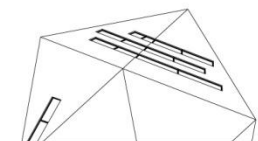

IZGLED 4

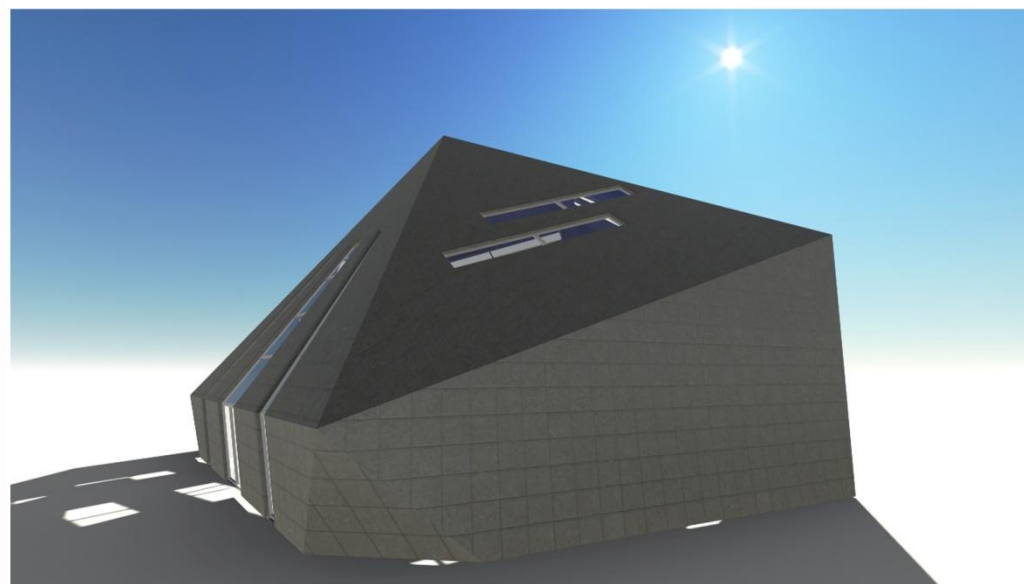

# Primena sekundarnog ikosaedra u arhitekturi

основа лампе,  $p=1:5$

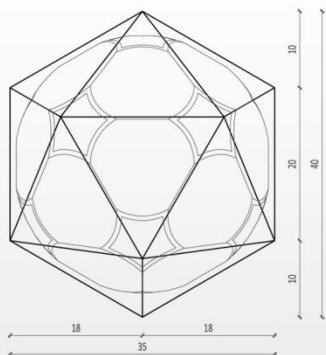

изглед лампе,  $p=1:5$

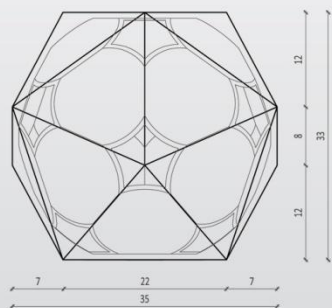

шема засецања икосаедра

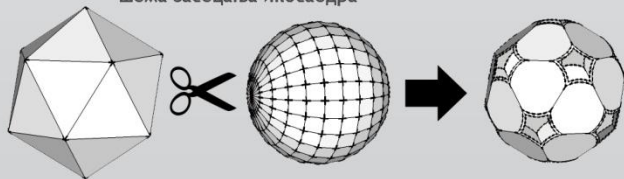

грађевинско-архитектонски факултет у новом сату  
геометријске површи у архитектури  
Ненад Јовановић мр 212/12

1



пројекат музеја

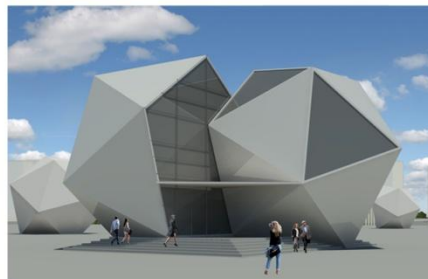
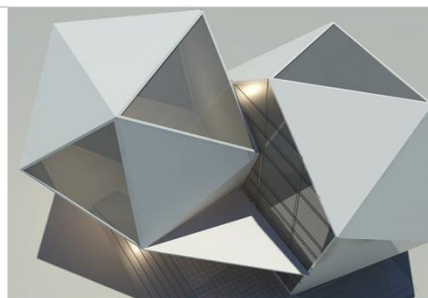

Основа

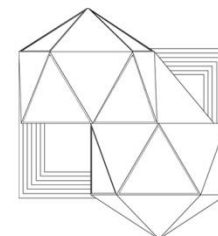

Изгледи

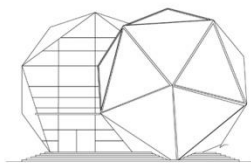
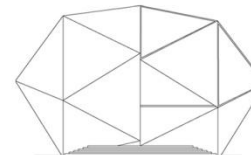
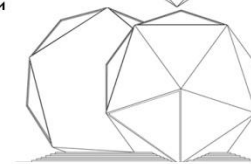

# Primena ikosaedra u arhitekturi



Aleksandar Nikolić, GPA, grafički rad, student generacija 2013/14





# Primena ikosaedra u arhitekturi

## 1. ПРАВИЛНИ ИКОСАЕДАР

основа објекта 0 1 2 3 4 5m



изглед објекта 0 1 2 3 4 5m

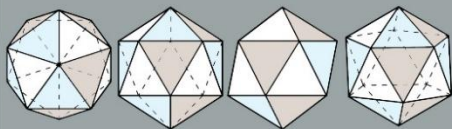
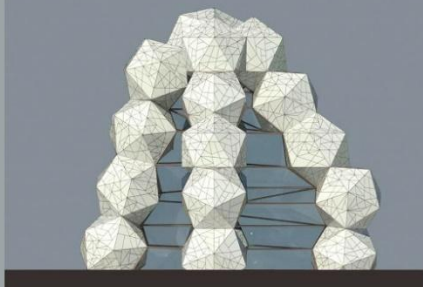

грађевинско-архитектонски факултет  
геометријске површи у архитектури  
студент: Милица Вељковић МРА 333/14



# Primena pentagonalnog dodekaedra u arhitekturi

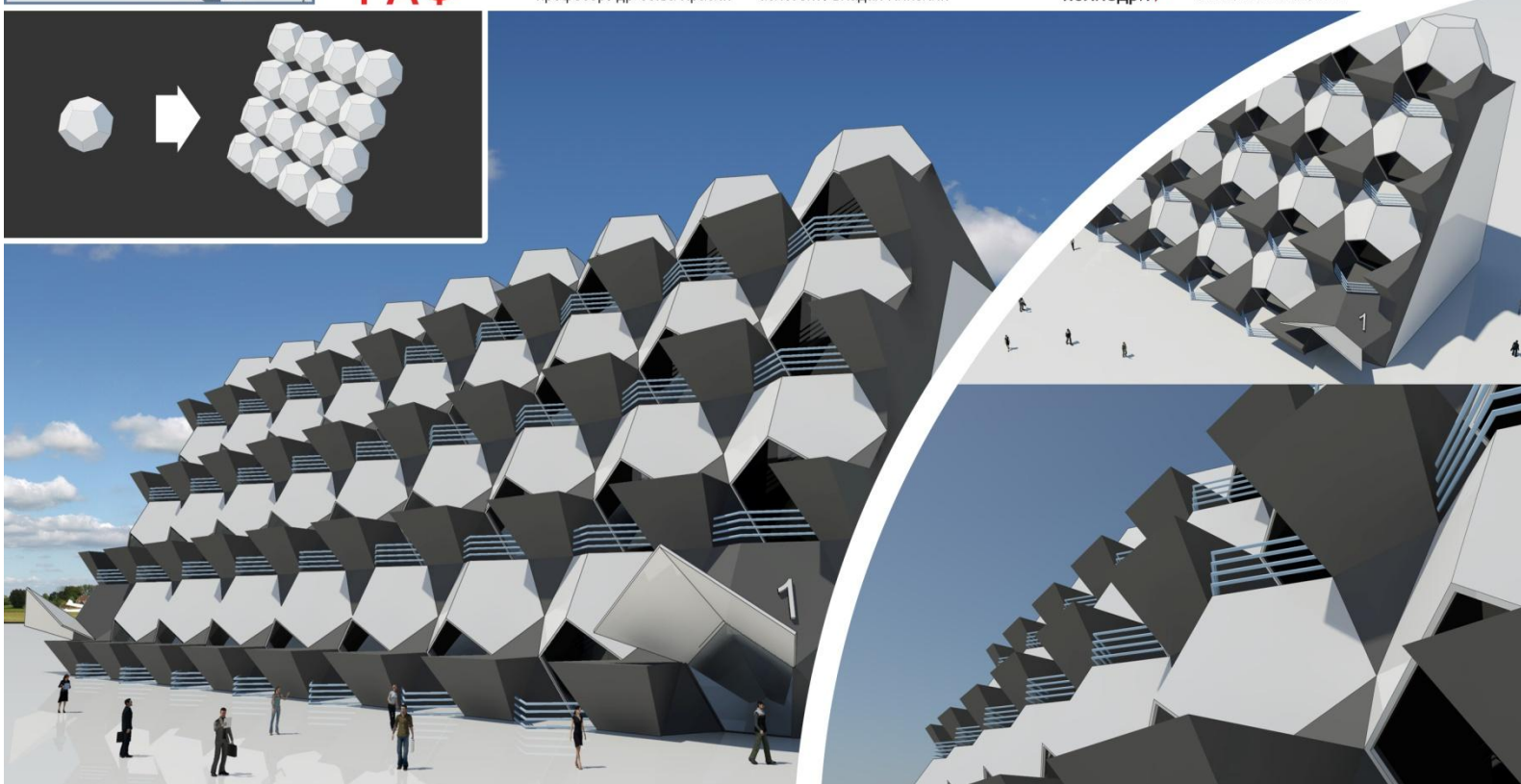
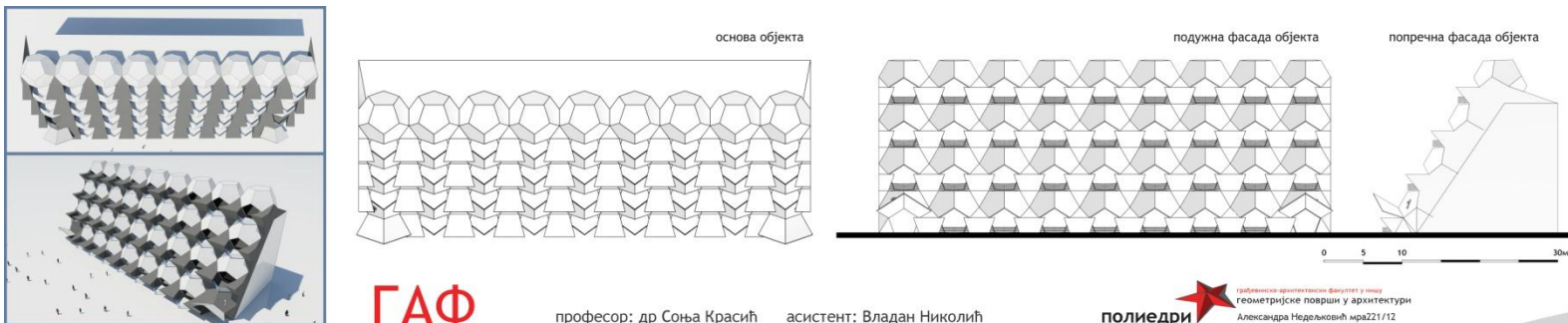

Aleksandra Nedeljković, GPA, grafički rad, student generacija 2012/13



# Primena pentagonalnog dodekaedra u arhitekturi

ДОДЕКАЕДАР

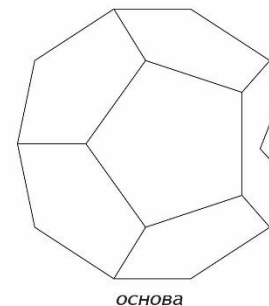
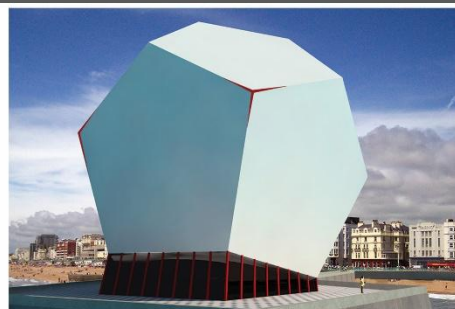
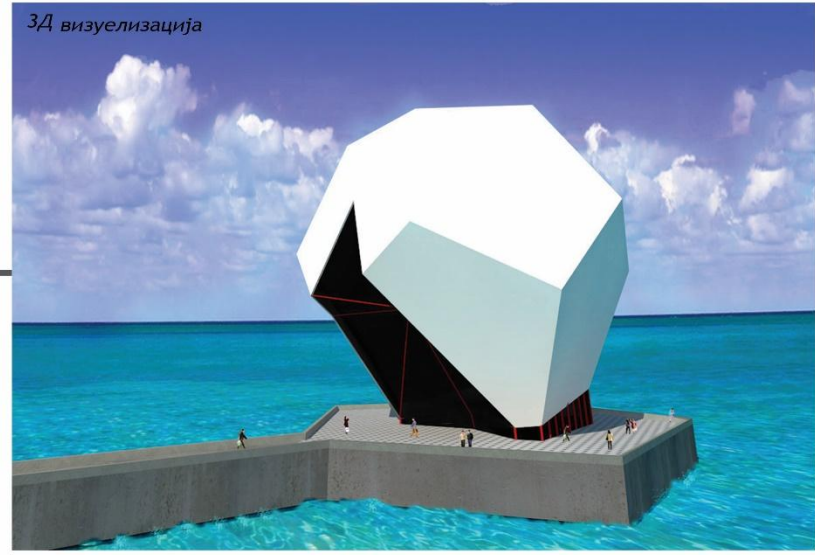
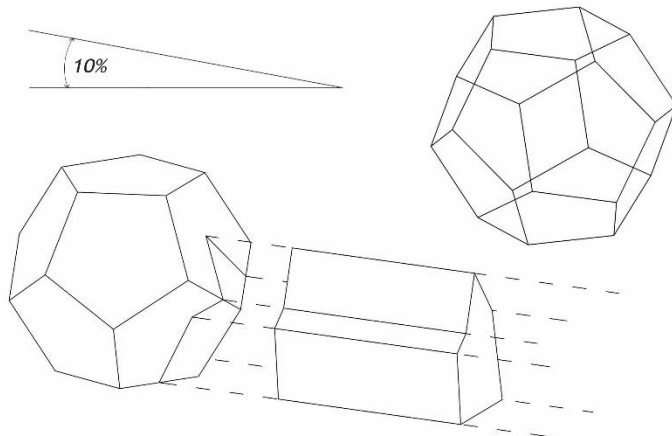
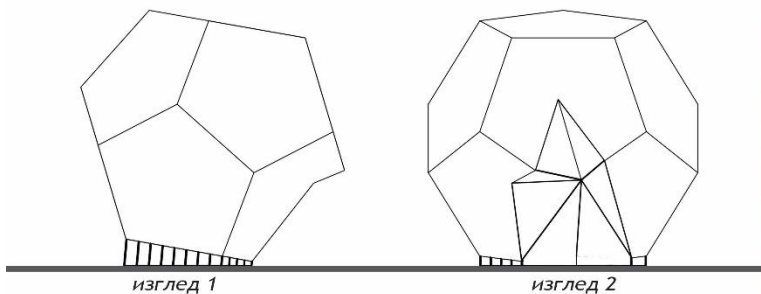

ОСНОВА

01



грађевинско-архитектонски факултет у нишу  
геометријске површи у архитектури

Марко Станковић МРА 270/13

# Primena pentagonalnog dodekaedra u arhitekturi

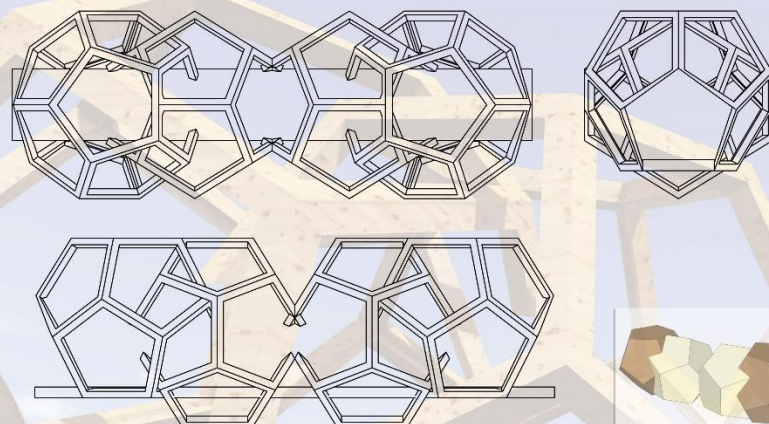

01



грађевинско-архитектонски факултет у нишу  
геометријске површи у архитектури  
Немања Вељковић МРА 302/13



# Primena pentagonalnog dodekaedra u arhitekturi

ДОДЕКАЕДАР

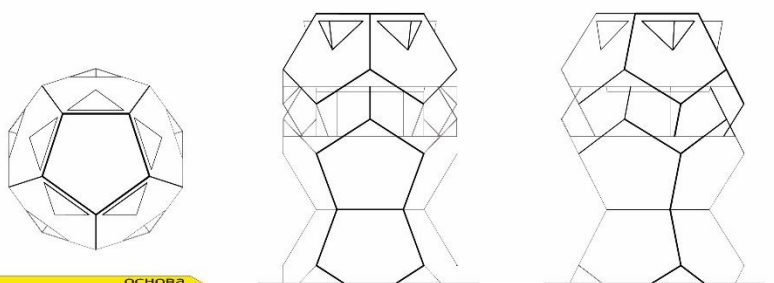
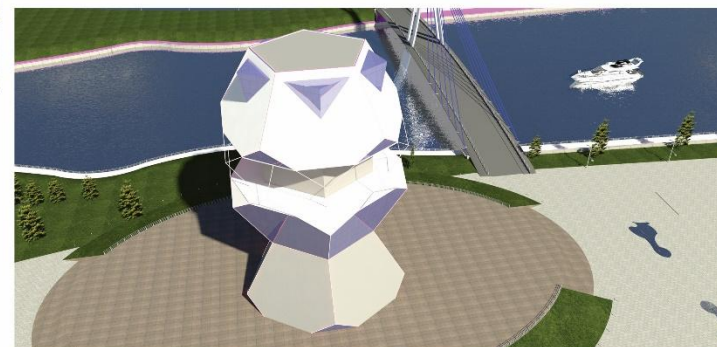
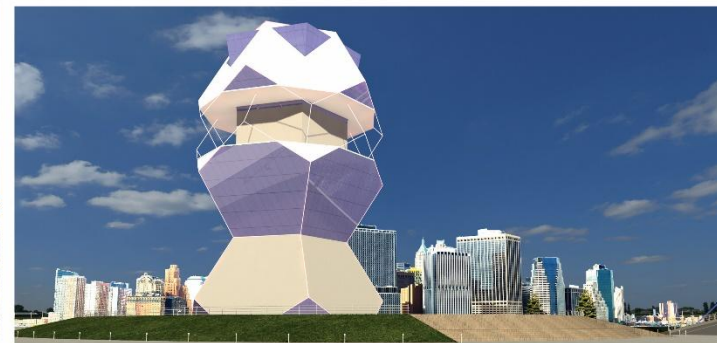
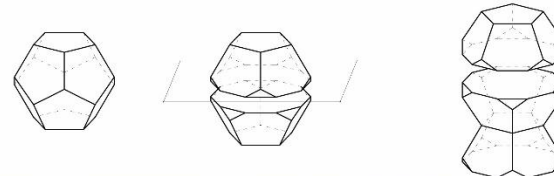

основа

изглед 1

изглед 2



01



грађевинско-архитектонски факултет у нишу  
геометријске површи у архитектури

Стефан Пешић МРА265/13

# Primena pentagonalnog dodekaedra u arhitekturi

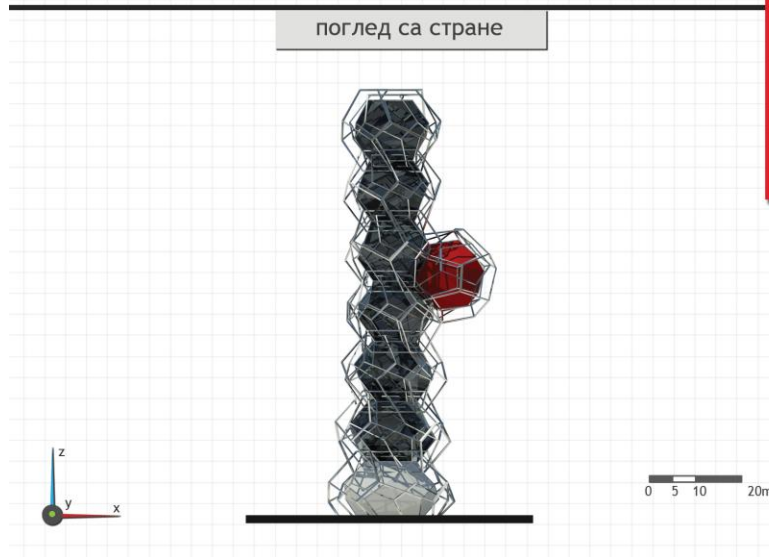
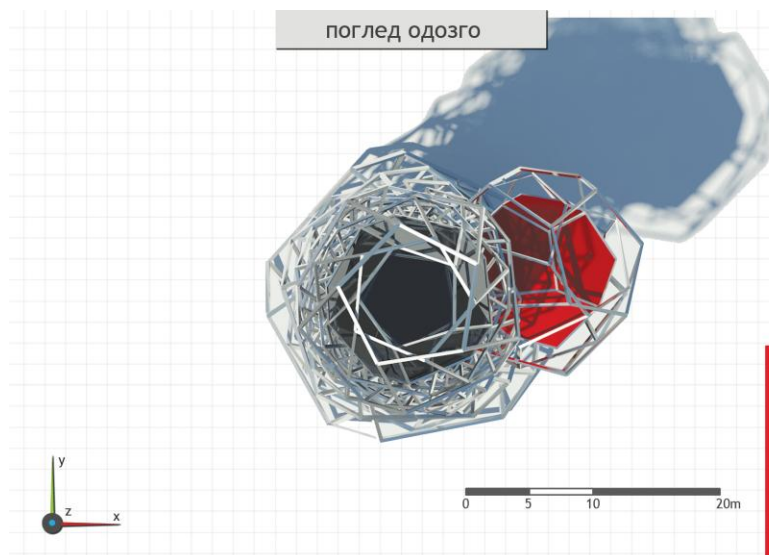

пентагонални додекаедар





# Primena pentagonalnog dodekaedra u arhitekturi



Miloš Ignjatović, GPA, grafički rad, student generacija 2014/15

# Primena pentagonalnog dodekaedra u arhitekturi



ОСНОВА

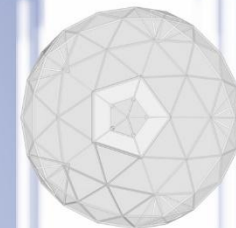

ПОГЛЕД СА СТРАНЕ

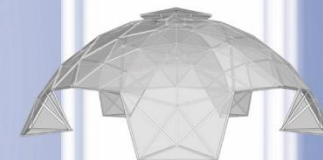

ФРОНТАЛНИ ПОГЛЕД

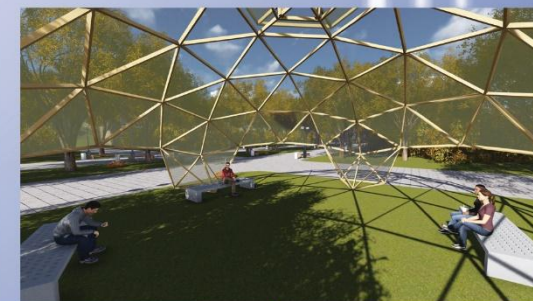
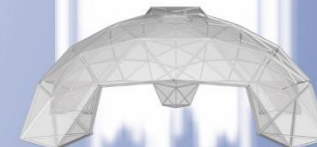

РАЗДВОЈЕНИ (СНУБ) ДОДЕКАЕДАР-01



# Primena pentagonalnog dodekaedra u arhitekturi

3д приказ објекта

ортогоналне пројекције објекта  
поглед одозго

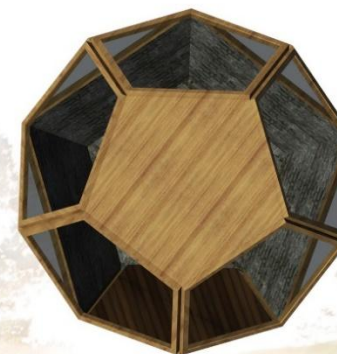

ортогоналне пројекције објекта  
изглед 1 и 2

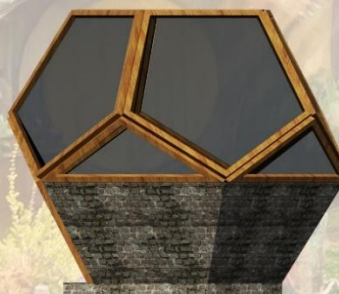

0 1 2 3 4 5m





### **Literatura:**

**Geometrijske površi u arhitekturi**, dr Sonja Krasić, Niš, Građevinsko-arhitektonski fakultet, 2012.g

**Nacrtna geometrija**, Prof. dr Miroslav Marković, Niš, 1998.g

<http://www.google.rs/>

tA, techniques&architecture, 309, Structures spatiales, un bilan

### **Crteži:**

Petar Pejić, student, gen. 2010/11