

## Veličina dvorišta i okućnice

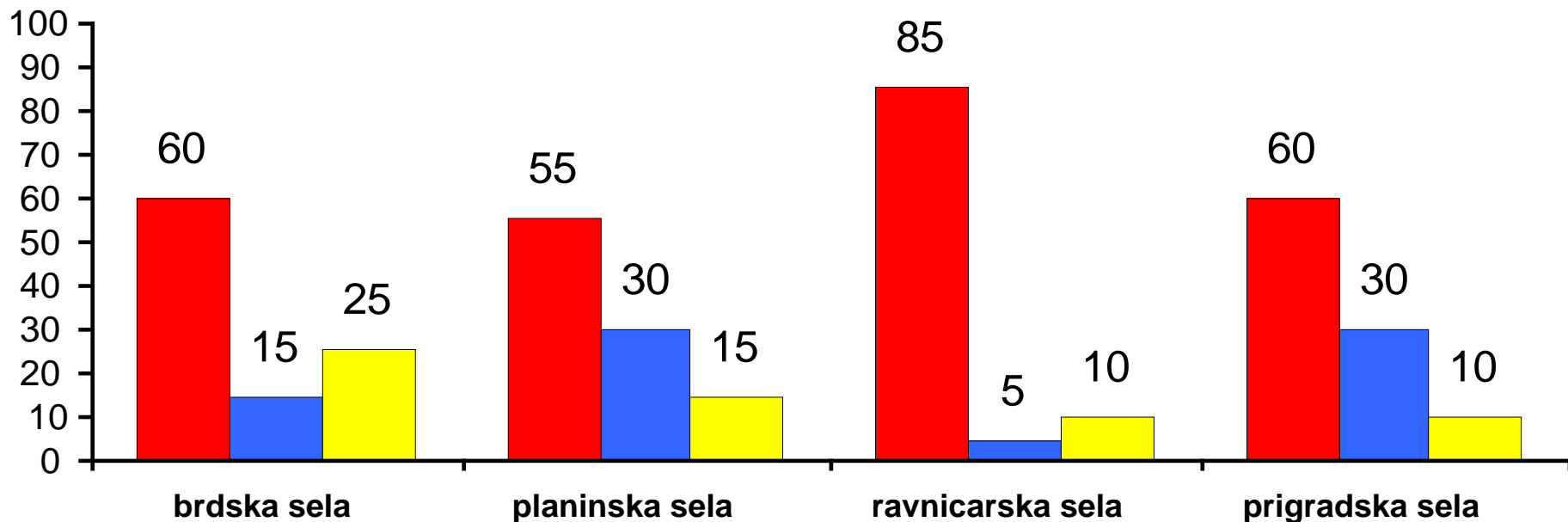

- zadovoljava
- ne zadovoljava
- oko granicne vrednosti

- površina dvorišta poljoprivredno orijentisanog domaćinstva bez voćnjaka iznosi 12-20ari, a sa voćnjakom ili okućnicom do 25ari,
- površina dvorišta mešovito orijentisanog domaćinstva iznosi 8-12ari, a
- površina dvorišta nepoljoprivredno orijentisanog domaćinstva iznosi 4-6ari.

*Pravilnik o opštim pravilima urbanističke regulacije i parcelacije (članovi 45-79):*

# Mala dvorišta

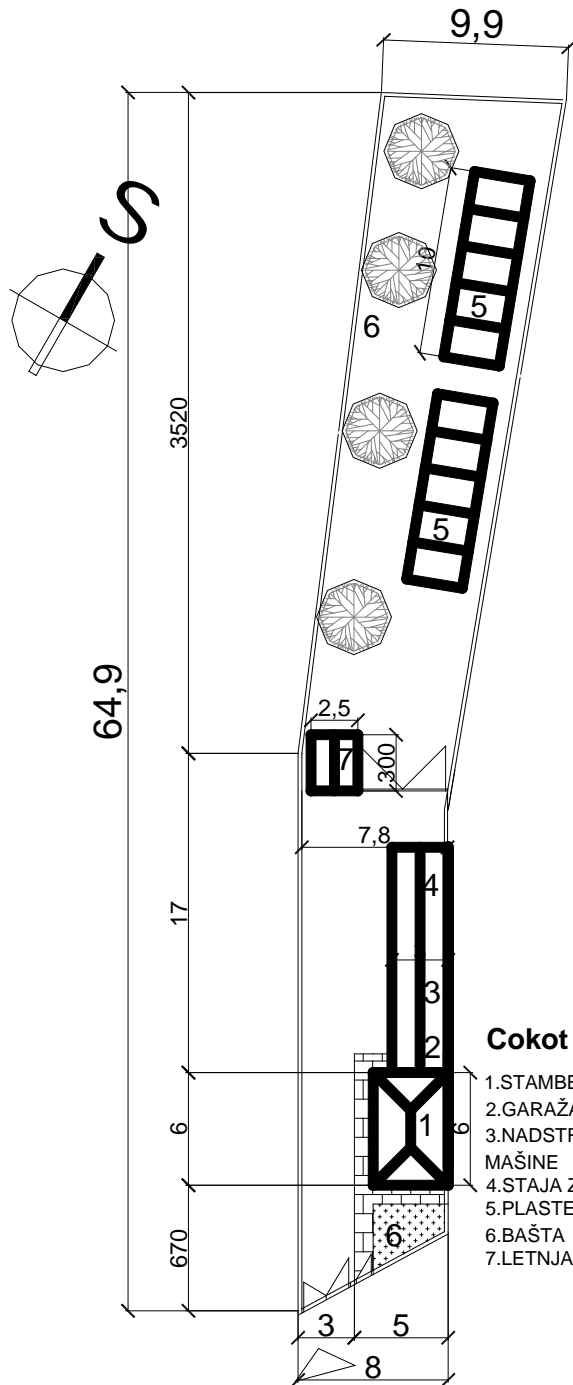

1. KUCA
2. STAJA ZA SVINJE I GOVEDA
3. GARAŽA ZA PUTNIČKO VOZILO
4. GARAŽA ZA TRAKTOR
5. LETNJA KUHINJA SA MLEKAROM
6. ŽIVINARNIK
7. STAJNJAK

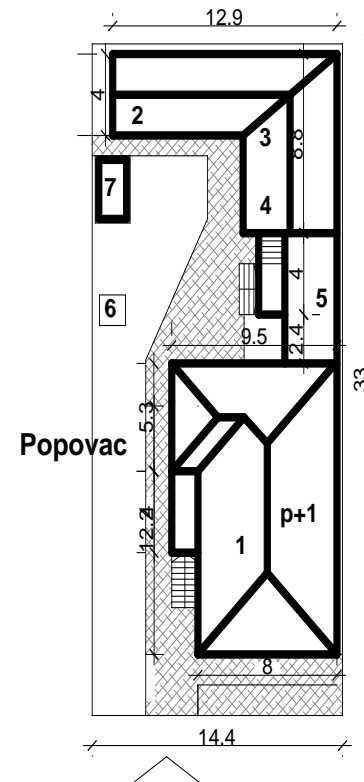

# Mala dvorišta

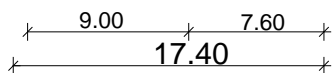
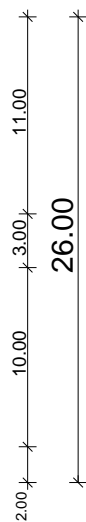
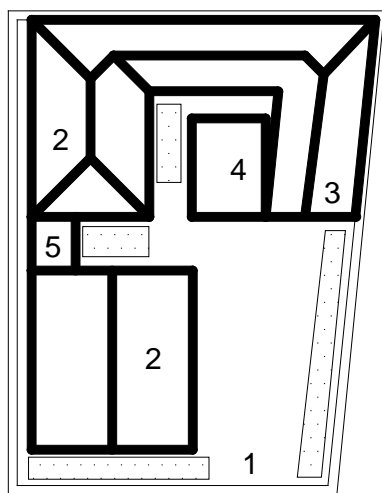

## Suvi Do

1. ULAZ U DVORIŠTE
2. KUĆA
3. GARAŽA
4. MAGACIN
5. KOTLARNICA

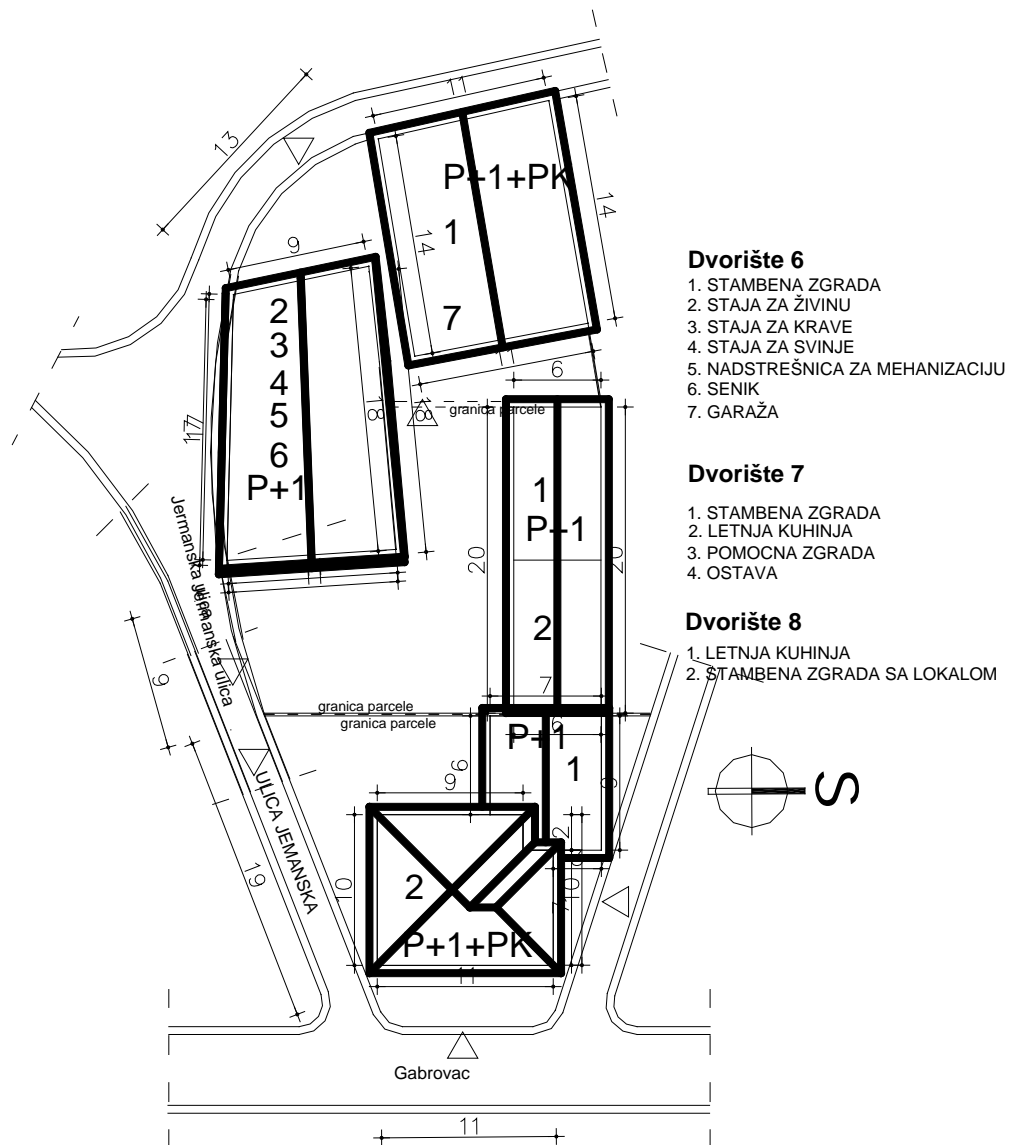
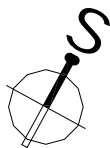

## Dvorište 6

1. STAMBENA ZGRADA
2. STAJA ZA ŽIVINU
3. STAJA ZA KRAVE
4. STAJA ZA SVINJE
5. NADSTREŠNICA ZA MEHANIZACIJU
6. SENIK
7. GARAŽA

## Dvorište 7

1. STAMBENA ZGRADA
2. LETNJA KUHINJA
3. POMOĆNA ZGRADA
4. OSTAVA

## Dvorište 8

1. LETNJA KUHINJA
2. STAMBENA ZGRADA SA LOKALOM

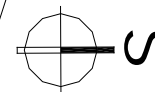

# Velika dvorišta

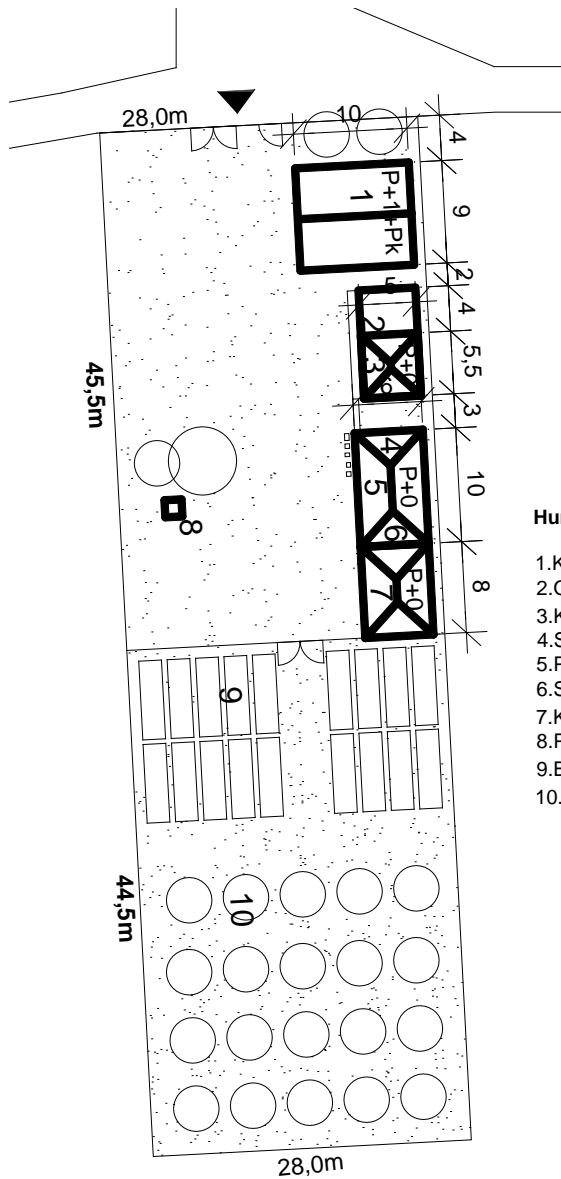

## Hum

1. KUĆA
2. OSTAVA
3. KOŠ ZA KUKURUZ
4. STAJA ZA SVINJE
5. PLEVNJA
6. STAJA ZA GOVEDA
7. KOKOŠINJAC
8. POLJSKI WC
9. BAŠTA
10. VOCNJAK

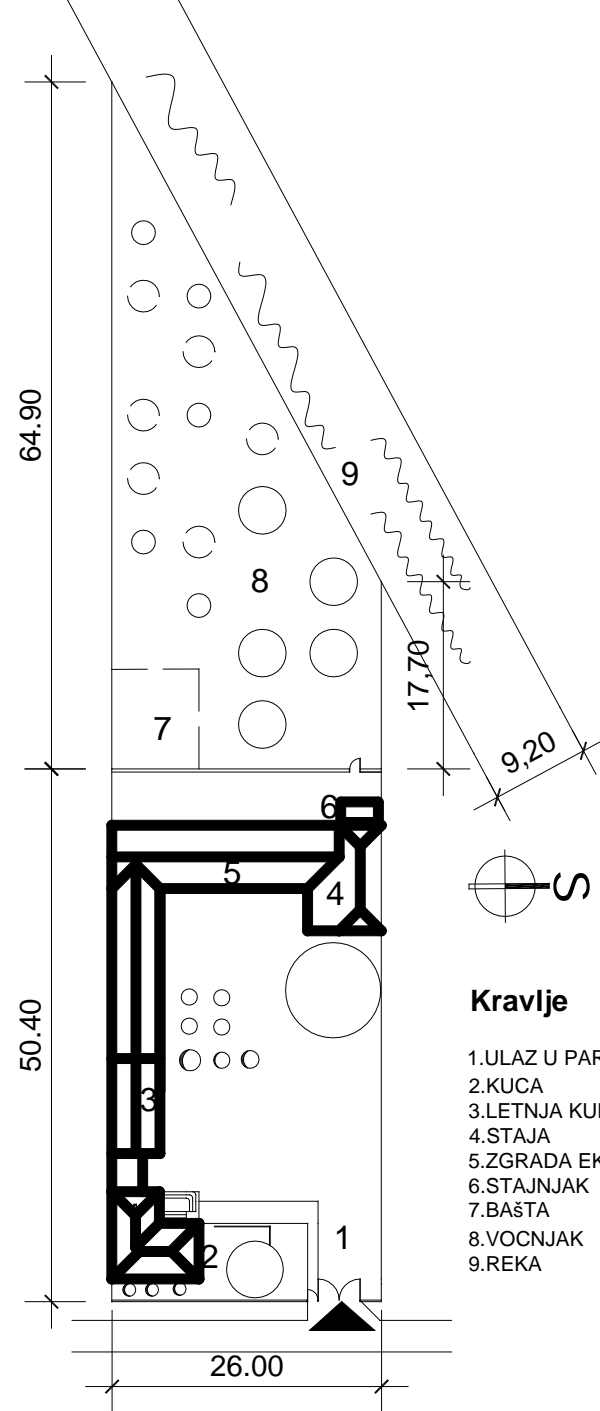

## Krvlje

1. ULAZ U PARCELU
2. KUĆA
3. LETNJA KUHINJA
4. STAJA
5. ZGRADA EKONOMATA
6. STAJNJAK
7. BAŠTA
8. VOCNJAK
9. REKA

# Forma dvorišta

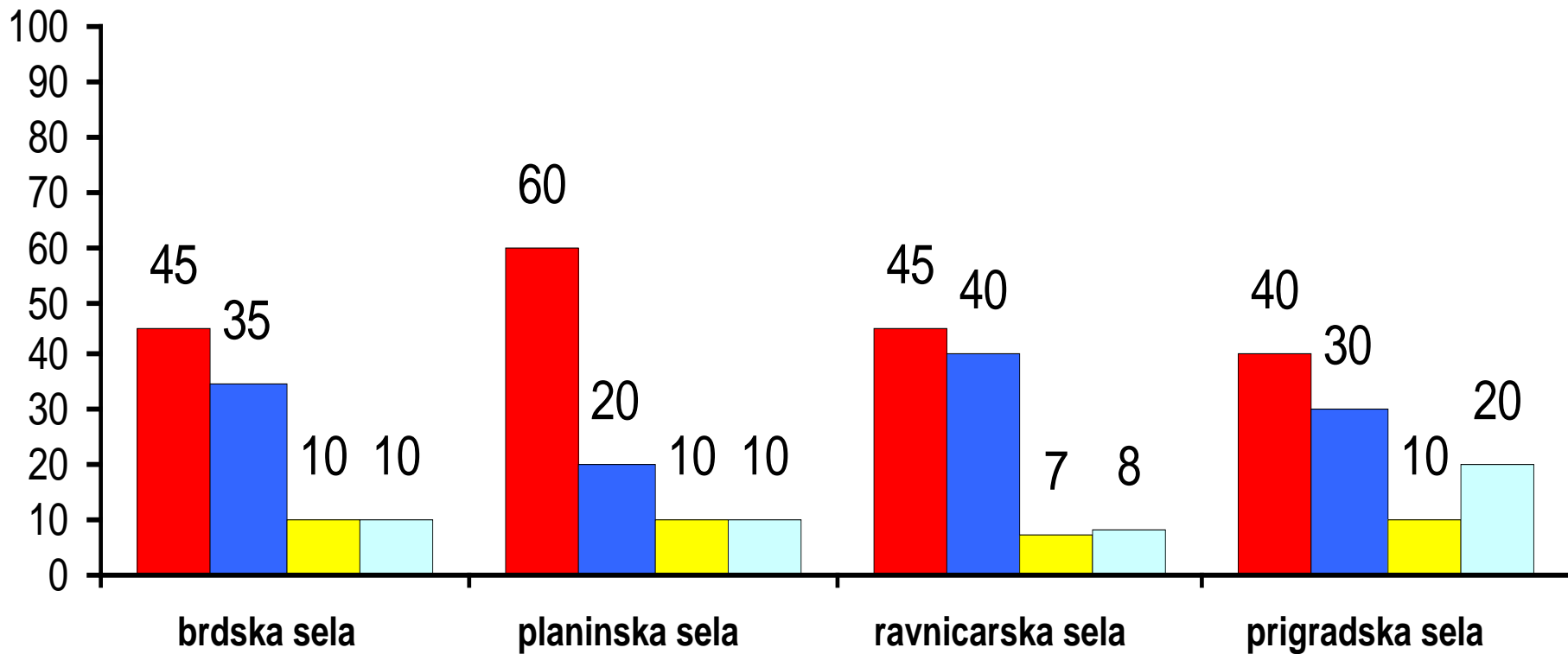

- pravougaona forma
- izduzena forma
- kvadratna i trapezna forma
- nepravilna forma

# Pravougaona forma

## Pasi Poljana

- 1.KUCA
- 2.LETNJA KUHINJA I POMOCNE PROSTORIJE
- 3.NADSTREŠNICA ZA TRAKTOR
- 4.STAJA ZA KRAVE
- 5.GARAŽA
- 6.SUŠNICA
- 7.KAVEZ ZA ZECEVE
- 8.BOKS ZA SVINJE
- 9.ĐUBRIŠTE

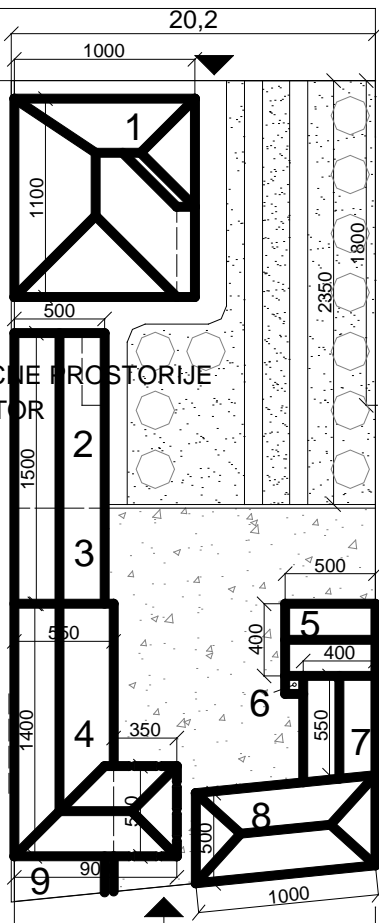

- 1.STAMBENI OBJEKAT
- 2.LETNJA KUHINJA I POMOCNA ZGRADA ZA STANOVANJE
- 3.GARAŽA
- 4.LETNJA KUHINJA
- 5.GARAŽA ZA PRIKLJUCNA VOZILA
- 6.STAJA ZA KRAVE (SPRATU IZNAD 3.4.5.6 NALAZI SE KOS ZA KUKURUZ I OSTAVE ZRNASTE HRANE)
- 7.STAJNJAK
- 8.SVINJAC
- 9.STAJA ZA KOZE (NA SPRATU IZNAD 8.9.10.11 NALAZI SE PROSTOR ZA SENO)
- 10.STAJA ZA OVCE
- 11.OSTAVE ZA HRANU
- 12.NADSTREŠNICA ZA TRAKTOR I PRIKLJUCNA VOZILA
- 13.POLJSKI WC
- 14.VOCNJAK
- 15.BAŠTA-ZELENILO
- 16.CESMA

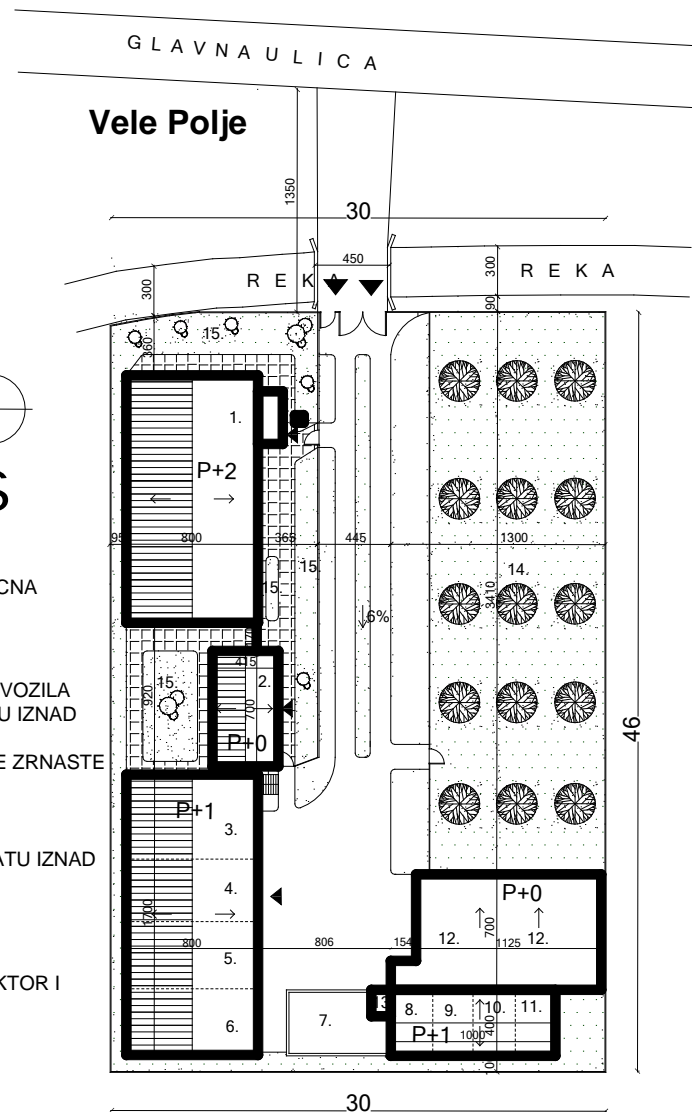

# Izdužena forma

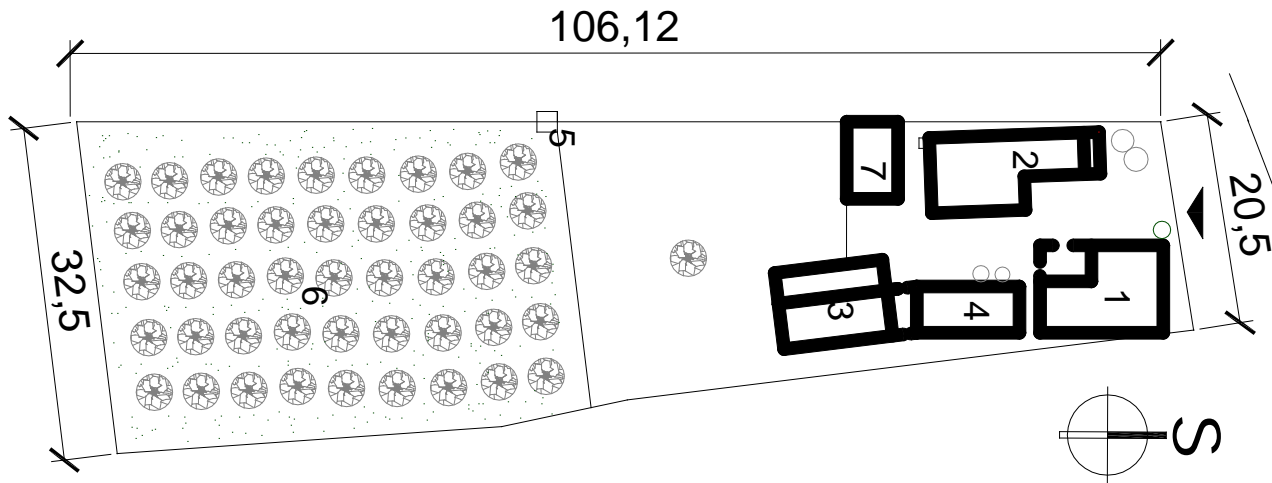

## Vele Polje

1. KUCA
2. NADSTREŠNICA, GARAŽA, STAJA i WC
3. SVINJAC i ŽIVINARNIK
4. LETNJA KUHINJA, KOŠ i KONCENTRAT
5. BUNAR
6. VOCNJAK
7. ĐUBRIŠTE

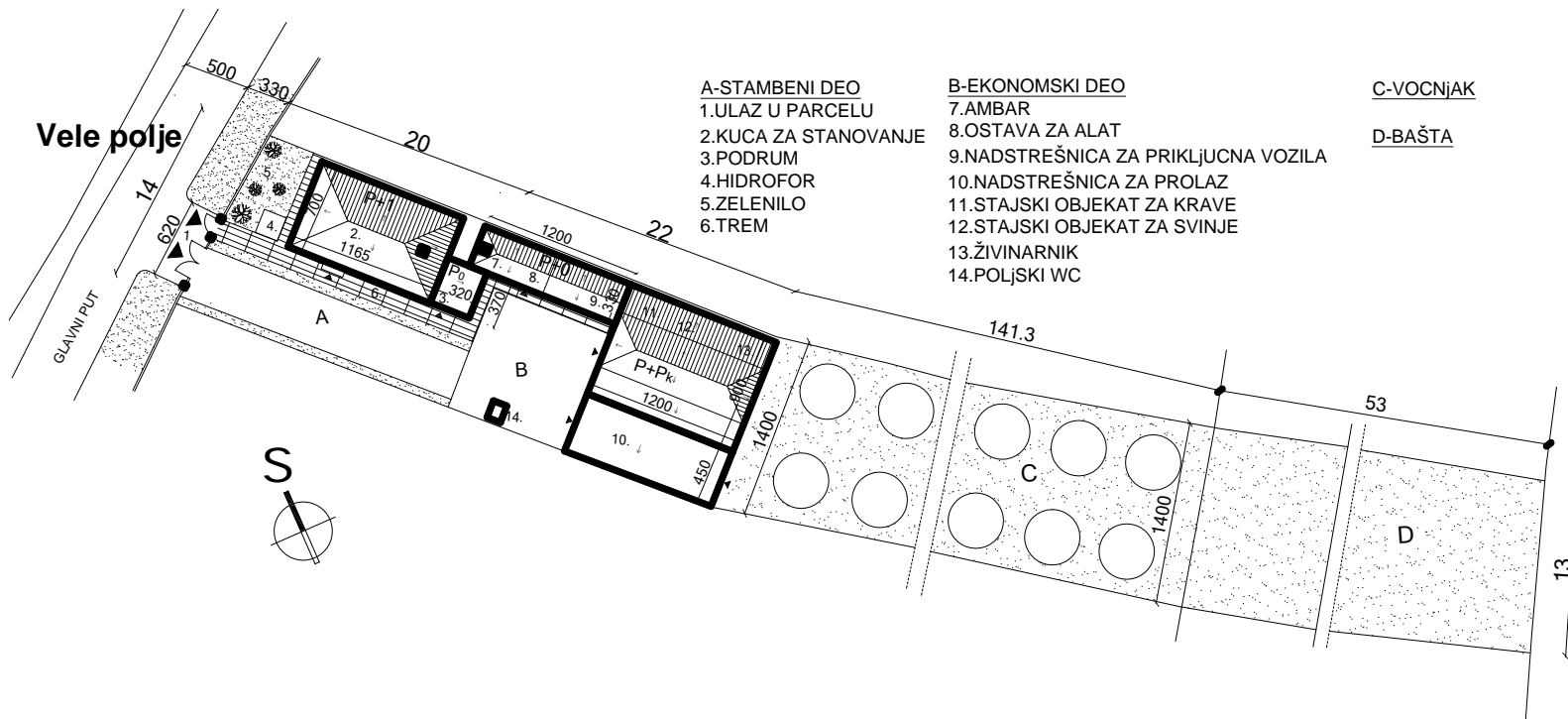



# Izdužena forma

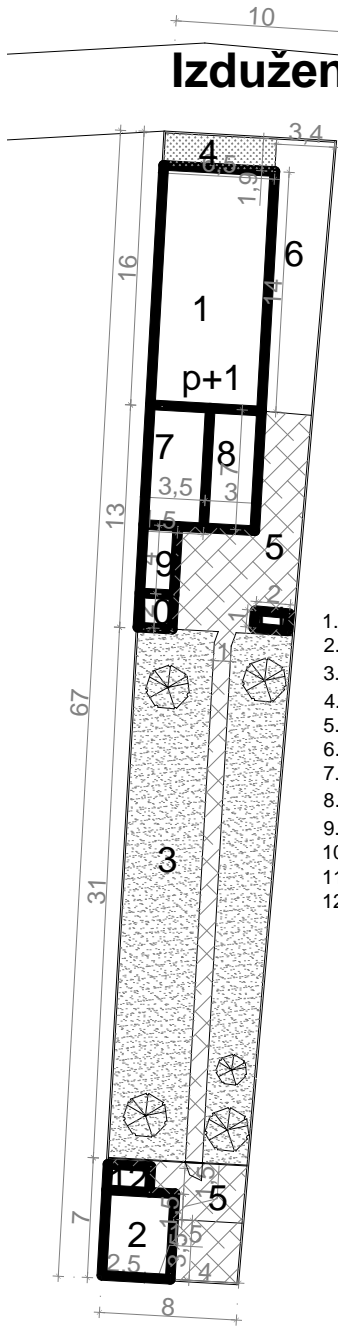

## Medoševac

1. KUCA
2. STAJA ZA TOVLJENIKE
3. BAŠTA
4. TRAVNATA POVRŠINA
5. STAZA OD NABIJENE ZEMLJA I TUCANIKA
6. BETONIRANA STAZA
7. LETNJA KUHINJA
8. NADSTREŠNICA
9. ŠUPA
10. OSTAVA ZA DRVA
11. KAVEZI ZA KANARINCE
12. STAJA ZA PATKE



## Bancarevo

1. KUCA
2. LETNJA KUHINJA
3. GARAŽA
4. PUŠNICA
5. AMBAR
6. KOKOŠARNIK
7. SVINJE
8. STAJA ZA GOVEDA
9. STAJNJE
10. NADSTREŠNICA ZA POLJOPRIVREDNE MAŠINE
11. VOCIJAK
12. PLATO, NABIJENA ZEMLJA

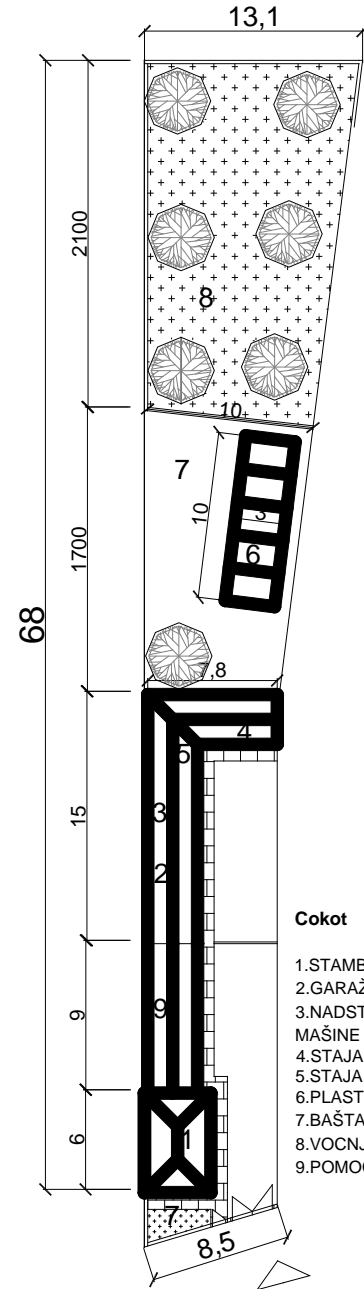

## Cokot

1. STAMBENI OBJEKAT
2. GARAŽA
3. NADSTREŠNICA ZA POLJ. MAŠINE
4. STAJA ZA GOVEDA
5. STAJA ZA SVINJE
6. PLASTENIK
7. BAŠTA
8. VOCIJAK
9. POMOĆNE PROSTORIJE

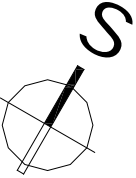

# Kvadratna-trapezna forma

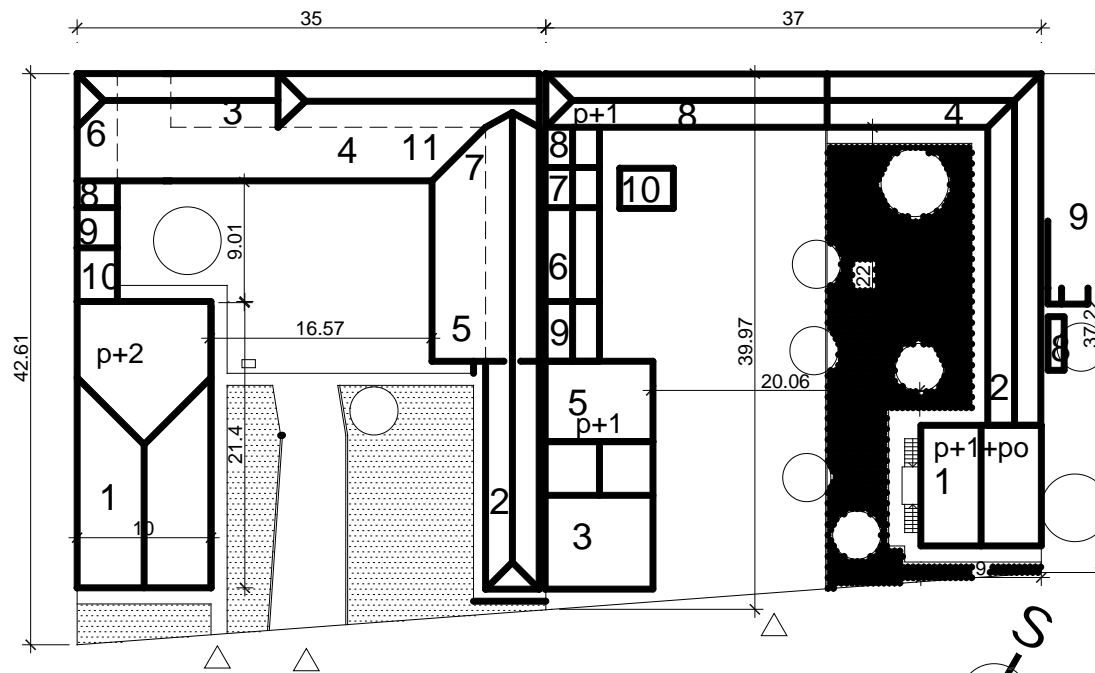

## Dvorište 1

1. NOVA KUĆA
2. STARA KUĆA
3. VULKANIZERSKA RADNJA
4. NADSTREŠNICA ZA PRIKLJUCNE MAŠINE
5. AMBAR
6. SVINJAC
7. STAJA
8. ŽIVINARNIK
9. ŠUPA
10. OSTAVA
11. STAJNJAK

## Popovac

## Dvorište 2

1. NOVA KUĆA
2. STARA KUĆA
3. KUĆA U IZGRADNJI
4. LETNJA KUHINJA
5. AUTOMEHANIČARSKA RADNJA
6. NADSTREŠNICA ZA PRIKLJUCNE MAŠINE
7. SVINJAC
8. STAJA
9. GARAŽA
10. STAJNJAK

# Kvadratna-trapezna forma

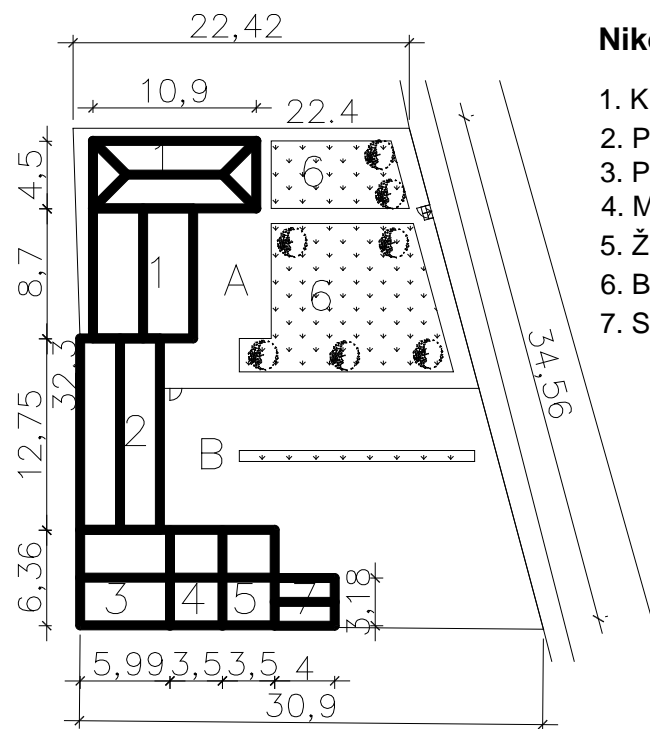
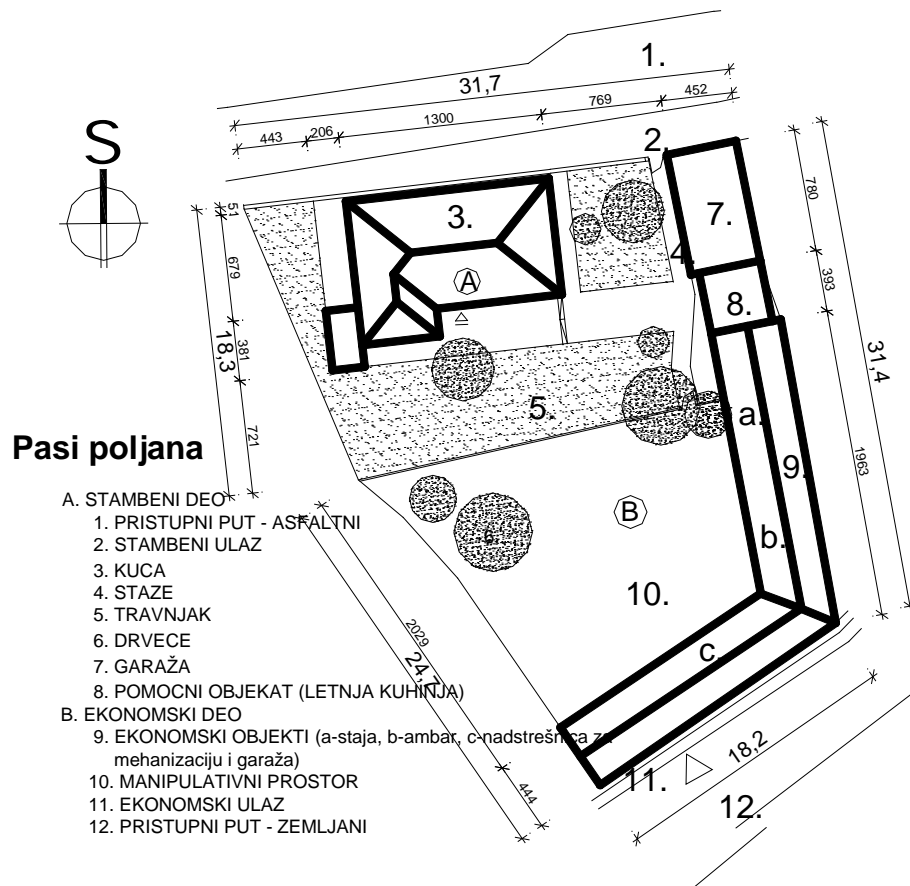

## Nikola Tesla

1. KUCA
2. POMOCNA ZGRADA
3. PLEVNJA
4. MEHANIZACIJA
5. ŽIVINARNIK
6. BAŠTA
7. SKLADIŠTE ZA DRVA

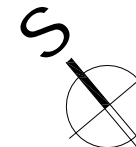

# Nepravilne forme

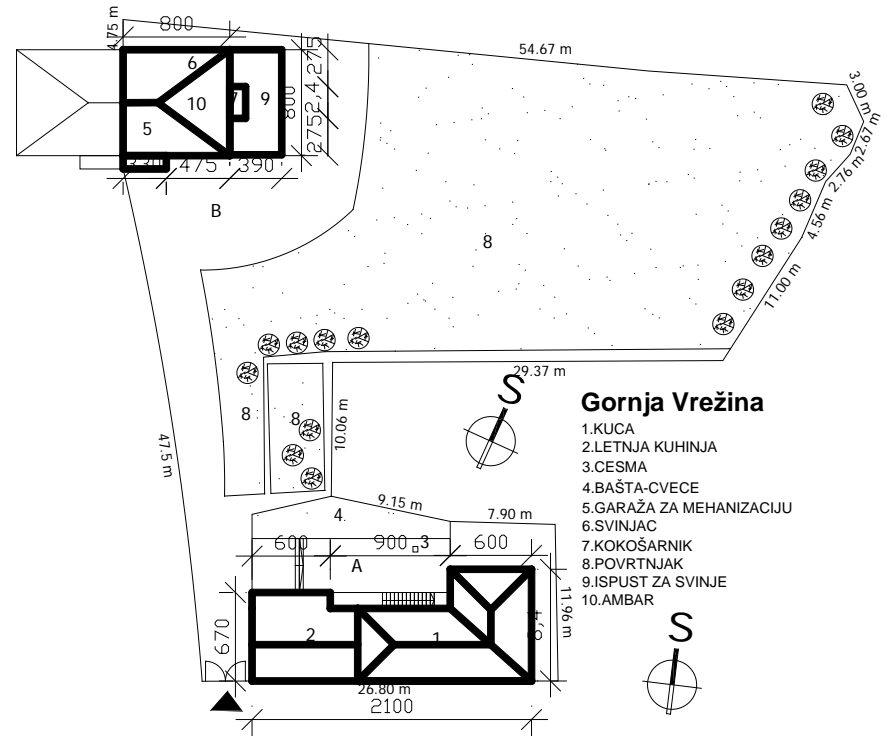
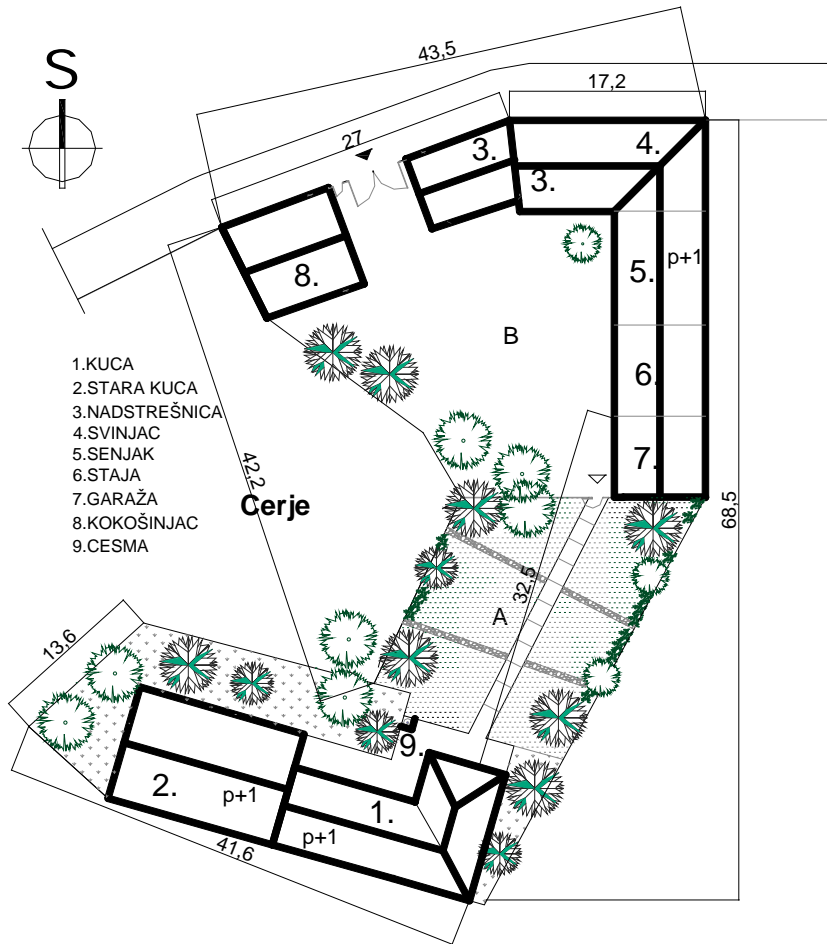

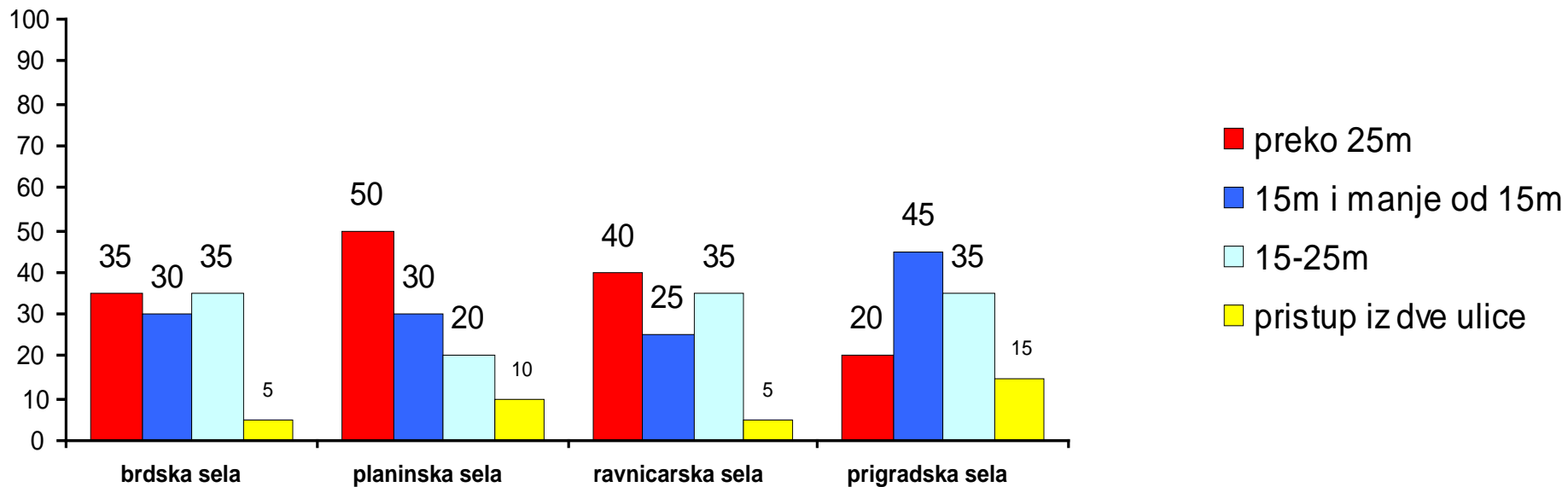
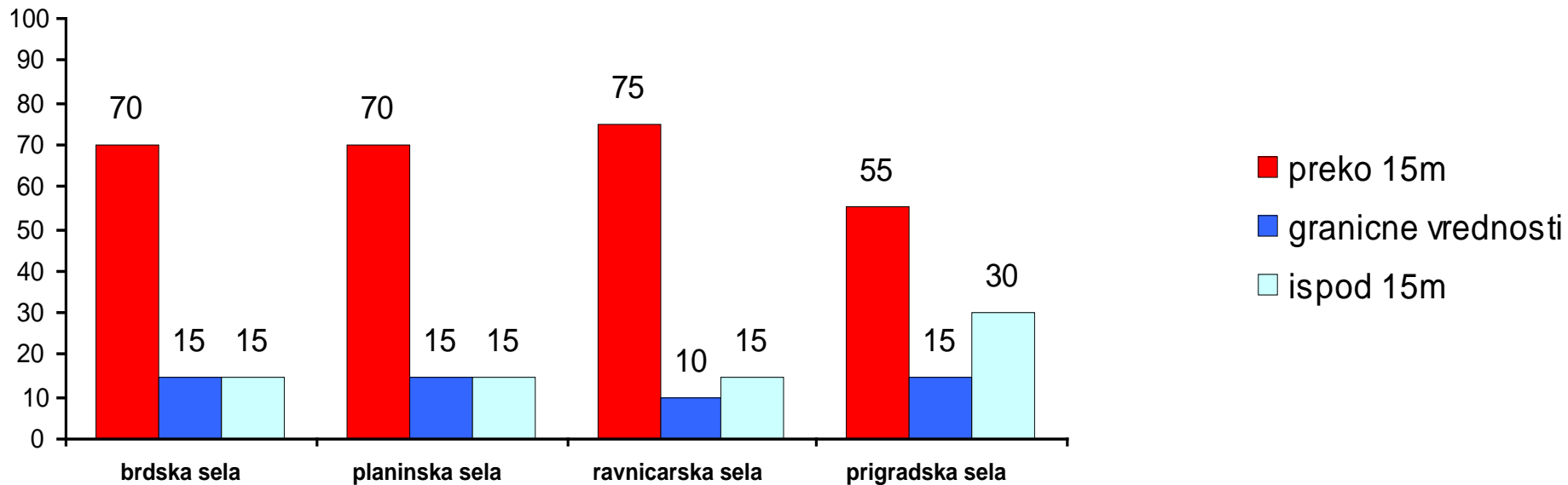

**Širina pristupnog fronta, prema preporučenim i propisanim vrednostima**



# Otežan pristup, manji od 15m

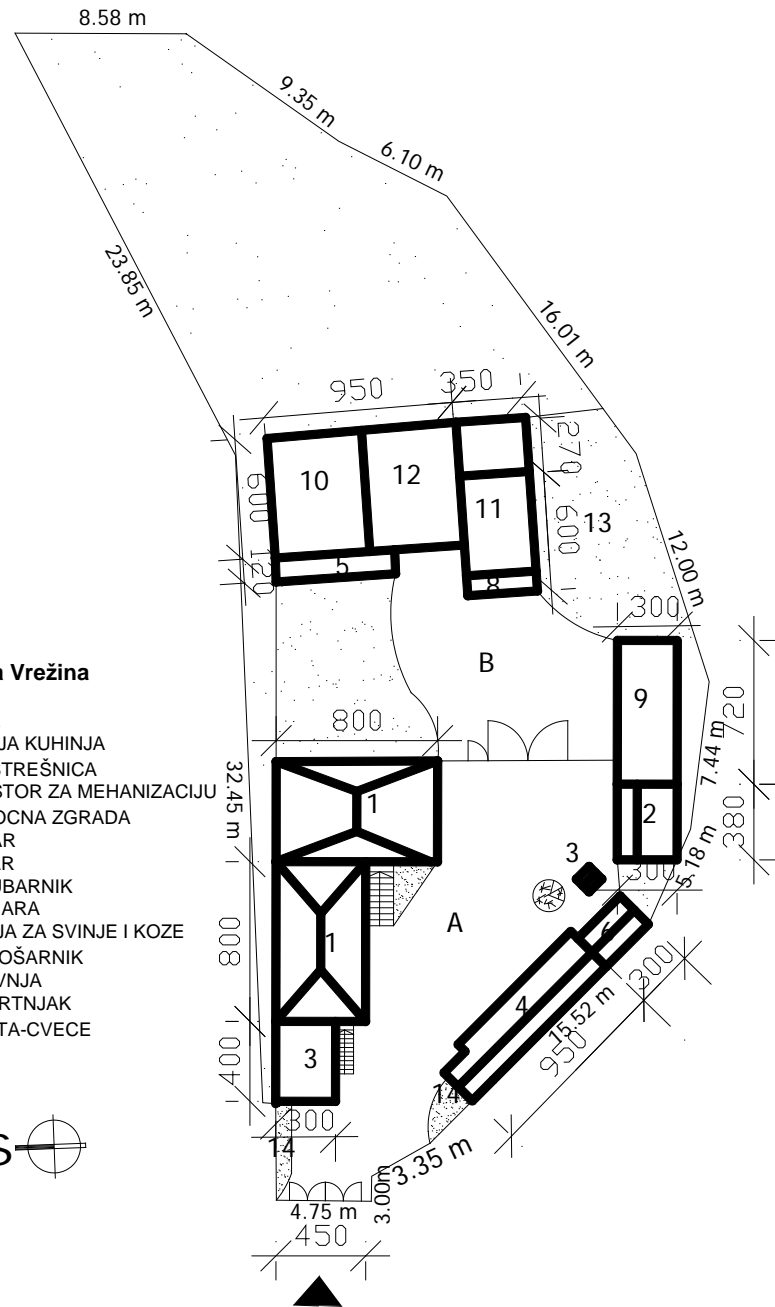
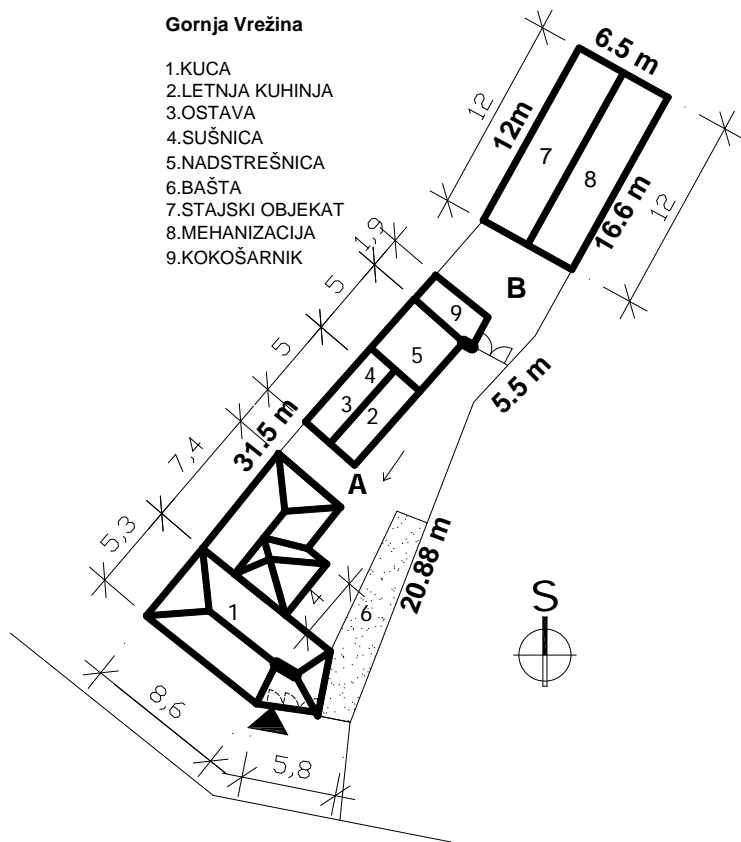

# Pristup iz dve ulice

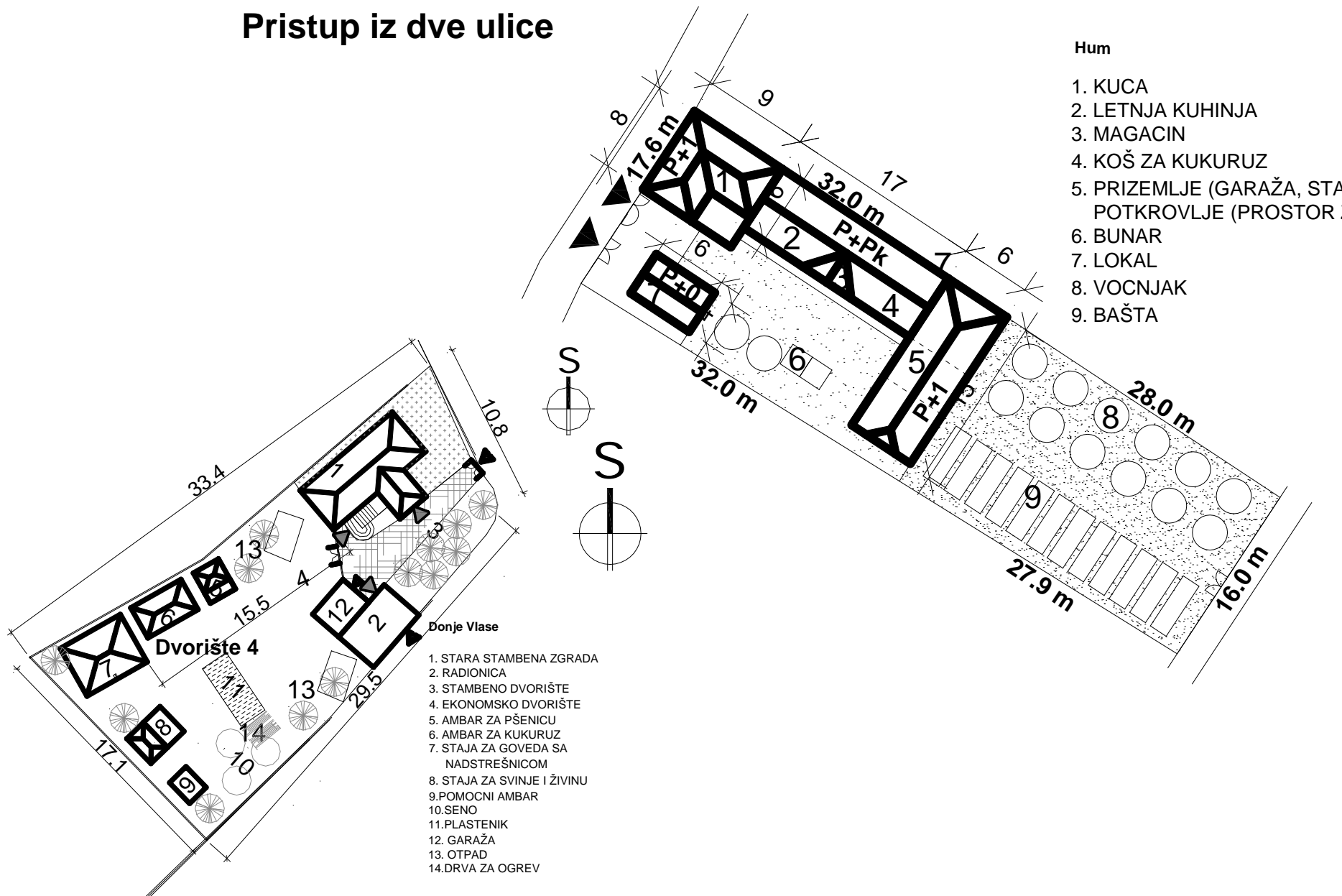



## Raspored objekata u dvorištu

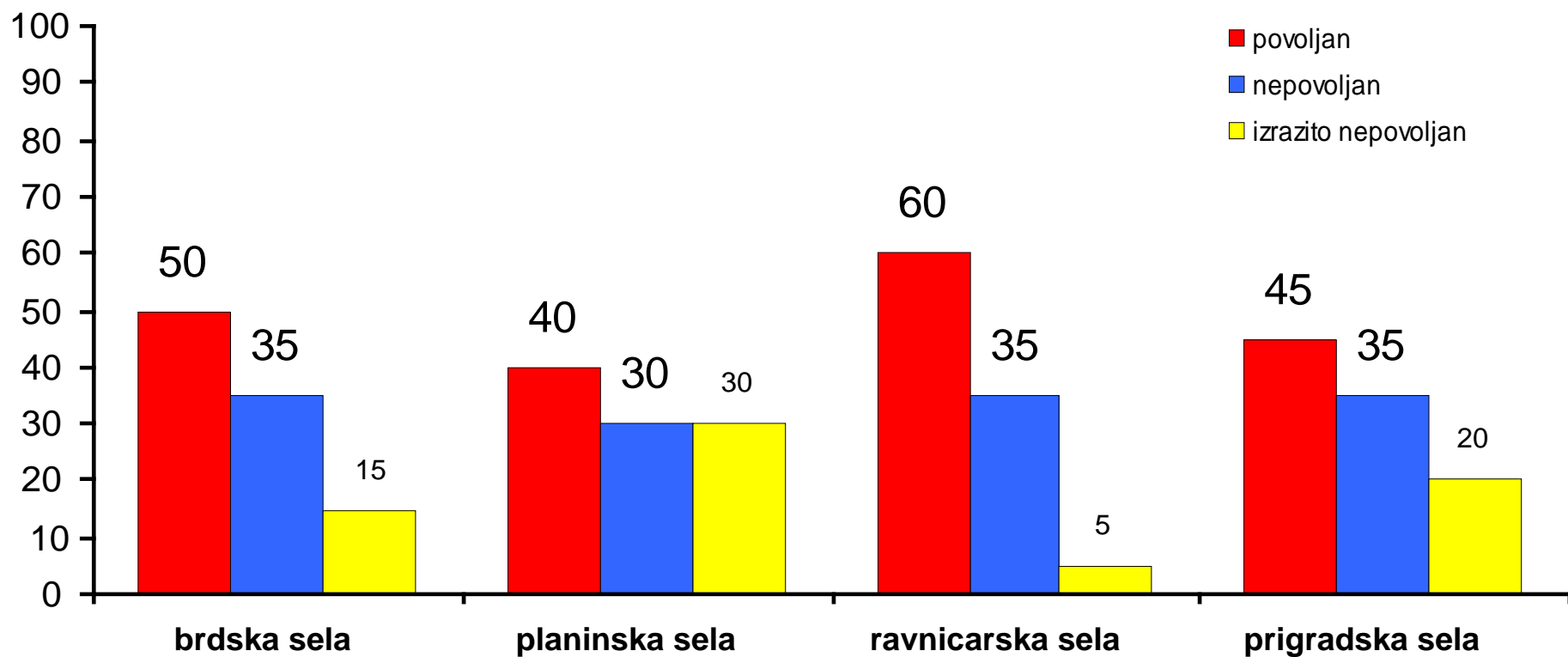

minimalno rastojanje stambenog objekta je: od staje 15m, a od đubrišta i poljskog wc-a 20-25m  
*Pravilnik o opštim pravilima urbanističke regulacije i parcelacije (članovi 45-79):*

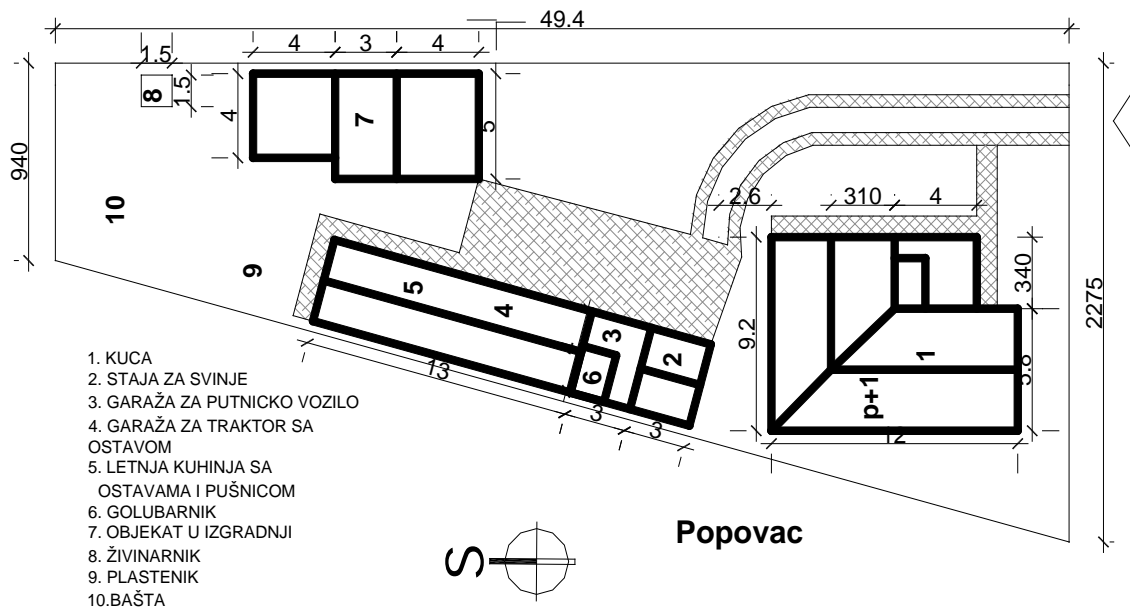

**Nepovoljan raspored objekata**

# Povoljan raspored- L raspored objekata

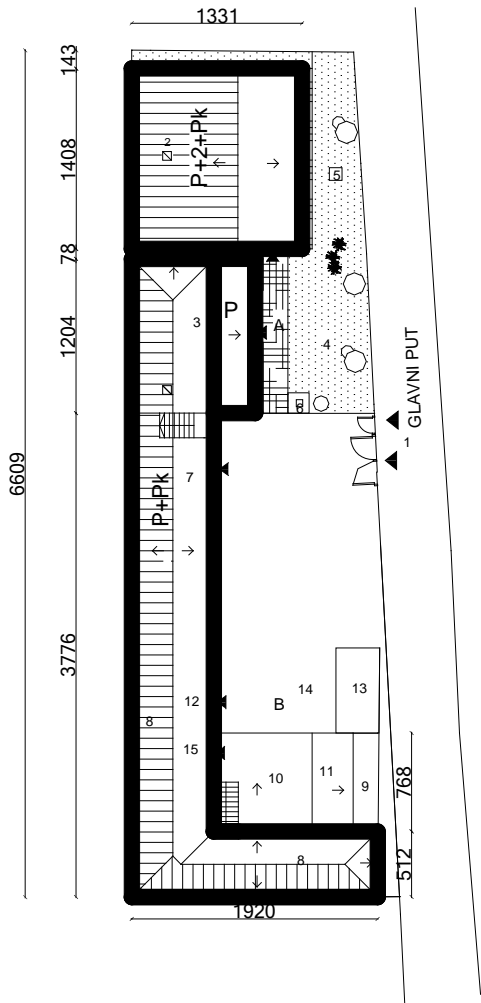

## Lainac

### A-STAMBENI DEO

1. ULAZ U PARCELU
2. KUĆA ZA STANOVANJE (NOVA)
3. KUĆA ZA STANOVANJE (STARA)
4. ZELENILO

5. SEPTIČKA JAMA
6. CESMA

### B-EKONOMSKI DEO

7. GARAŽA
8. OSTAVA HRANE
9. KOŠ ZA KUKURUZ
10. NADSTREŠNICA ZA PRIKLJUCNE MAŠINE
11. NADSTREŠNICA PORED KOŠA ZA KUKURUZ
12. STAJSKI OBJEKAT ZA SVINJE
13. STAJNJAK
14. POPLOCANJE
15. STAJSKI OBJEKAT ZA KRAVE

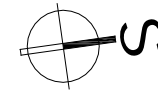
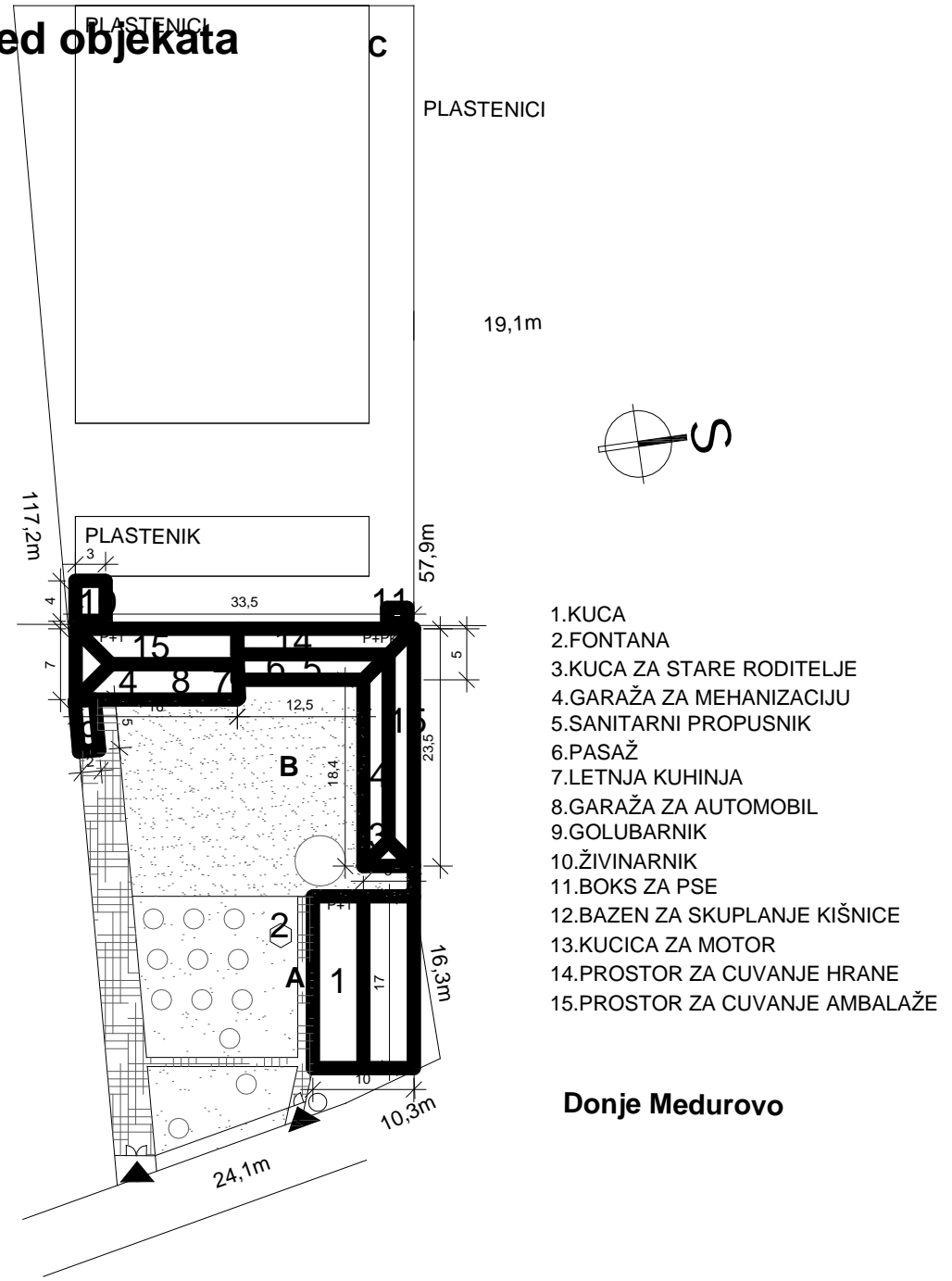

1. KUĆA
2. FONTANA
3. KUĆA ZA STARE RODITELJE
4. GARAŽA ZA MEHANIZACIJU
5. SANITARNI PROPUSNIK
6. PASAŽ
7. LETNJA KUHINJA
8. GARAŽA ZA AUTOMOBIL
9. GOLUBARNIK
10. ŽIVINARNIK
11. BOKS ZA PSE
12. BAZEN ZA SKUPLANJE KIŠNICE
13. KUCICA ZA MOTOR
14. PROSTOR ZA CUVANJE HRANE
15. PROSTOR ZA CUVANJE AMBALAŽE

Donje Medurovo

# Objekti raspoređeni u obliku slova U

## Povoljan raspored



### Lalinac

#### A-STAMBENI DEO

1. ULAZ U PARCELU
2. KUĆA ZA STANOVANJE (NOVA)
3. TERASA
4. KUĆA ZA STANOVANJE (STARA)
5. LETNJA KUHINJA (SA PODRUMOM)
6. NADSTERŠNICA
7. ZELENILLO
8. HIDROFOR

#### B-EKONOMSKI DEO

9. GARAŽA ZA TRAKTOR
10. OSTAVA HRANE
11. STAJSKI OBJEKAT ZA SVINJE
12. KOŠ ZA KUKURUZ

## Nepovoljan raspored

Medoševac

1. KUĆA ZA STANOVANJE
2. GARAŽE ZA PRIKLJUCNE MAŠINE
3. STAJE
4. STAJNJAK
5. RADIONICA
6. WC

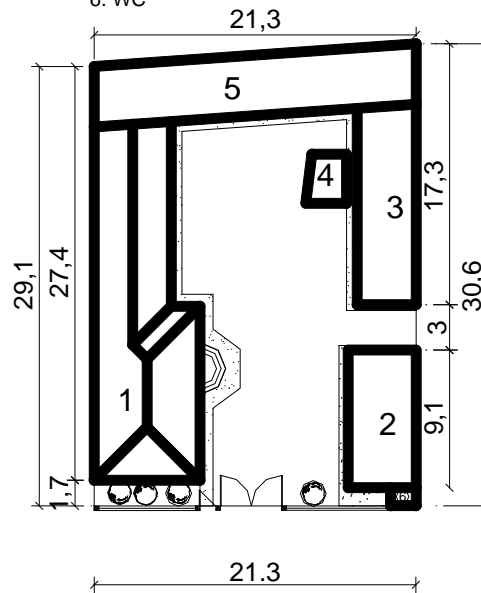

# Povoljan raspored- objekti raspoređeni u dva niza

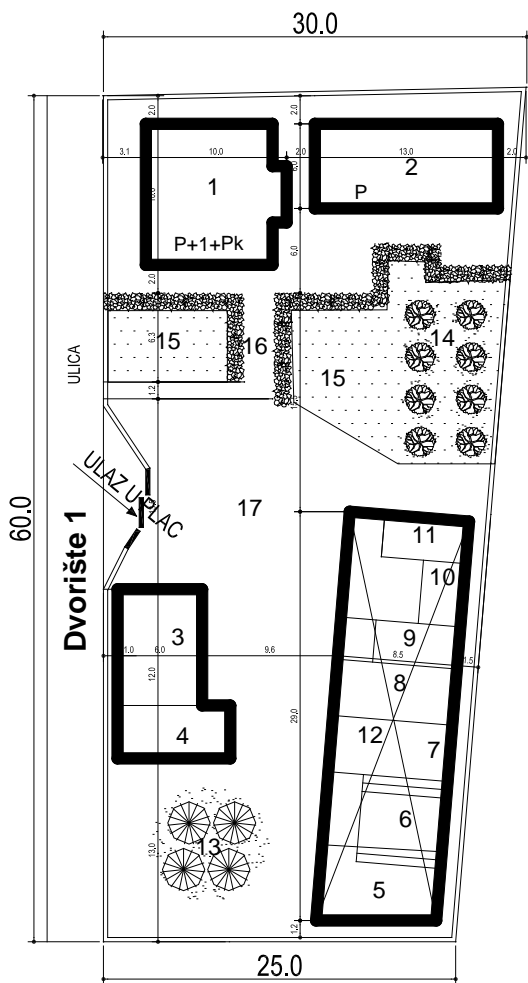

## Lalinac

- 1.NOVA KUCA
- 2.STARA KUCA
- 3.GARAŽA
- 4.OSTAVA ZA HRANU
- 5.STAJAZA KRAVE
- 6.STAJA ZA BIKOVE
- 7.SVINJAC
- 8.NADSTREŠNICA ZA MEHANIČACIJU
- 9.PROSTORIJA ZA ALAT
- 10.KOŠ ZA KUKURUZ
- 11.OSTAVA ZA ŽITO
- 12.TAVANSKI PROSTOR ZA SENO
- 13.STOGOVI SENA
- 14.VOCKE
- 15.BAŠTA
- 16.BETONSKI BOTOAR
- 17.NABIJENA ZEMLJA

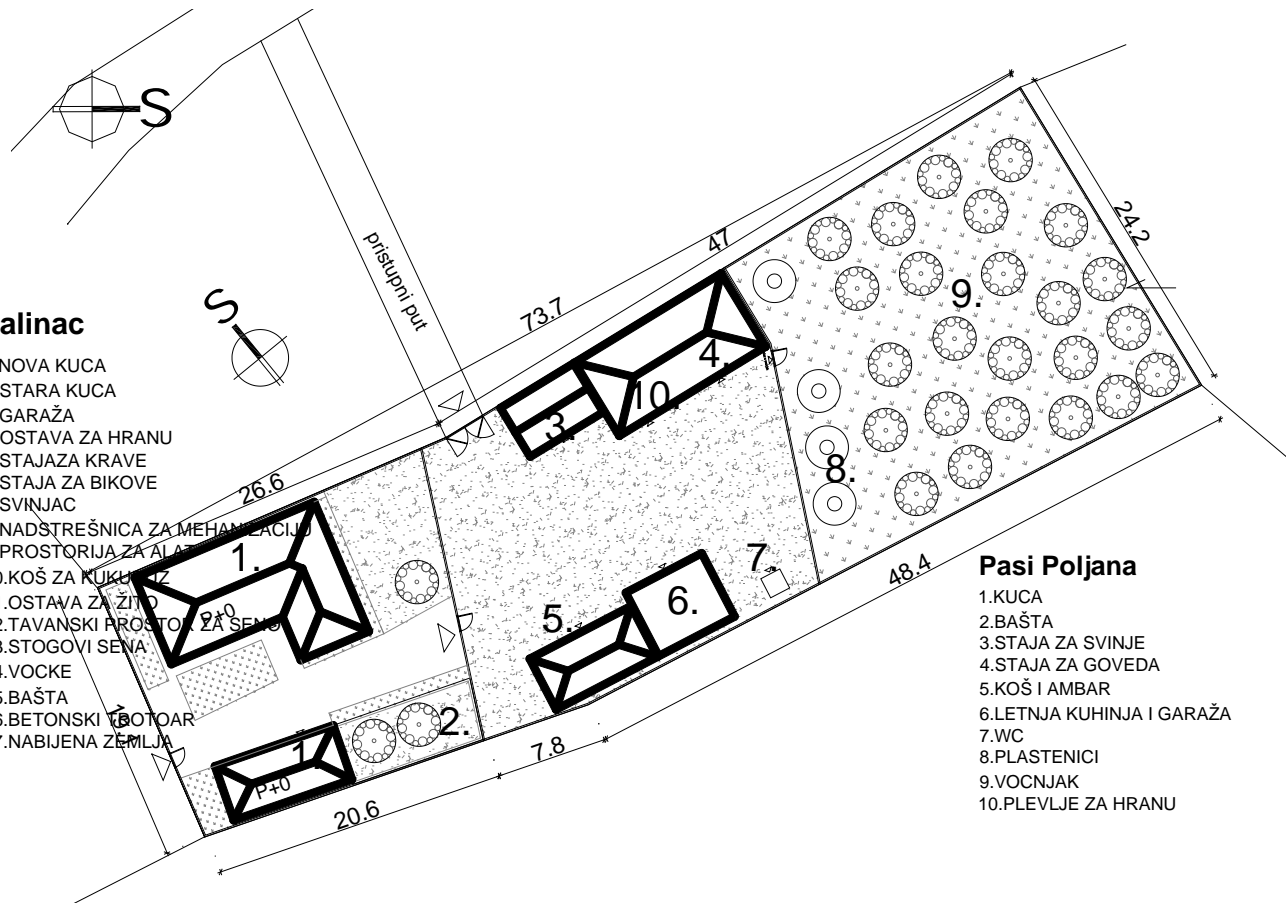

## Pasi Poljana

- 1.KUCA
- 2.BAŠTA
- 3.STAJA ZA SVINJE
- 4.STAJA ZA GOVEDA
- 5.KOŠ I AMBAR
- 6.LETNJA KUHINJA I GARAŽA
- 7.WC
- 8.PLASTENICI
- 9.VOCNJAK
- 10.PLEVLJE ZA HRANU

# Povoljan raspored- zatvoreno-atrijumsko dvorište

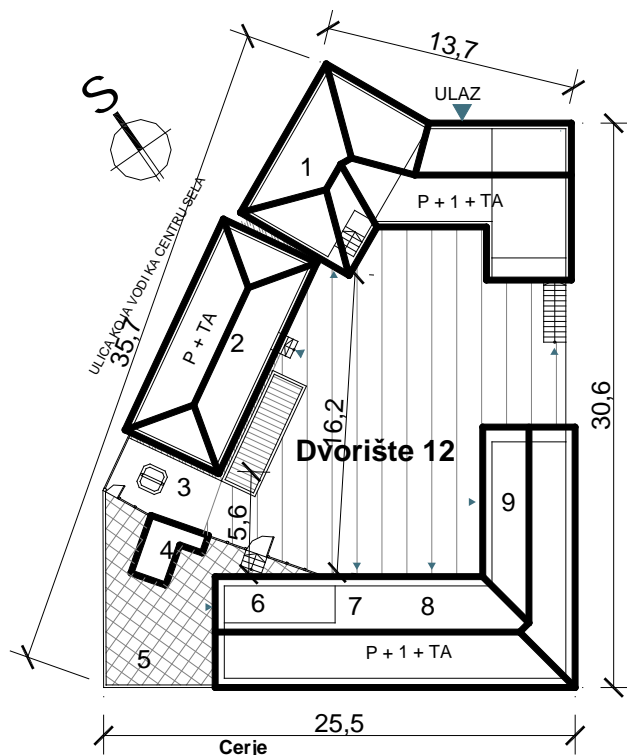

1. NOVA KUCA
2. STARA KUCA
3. BUNAR
4. POMOJNI OBJEKT
5. OTVORENI KOKOŠINJAC
6. STAJA
7. GARAŽA
8. GARAŽA
9. POMOJNI OBJEKAT SA AMBAROM

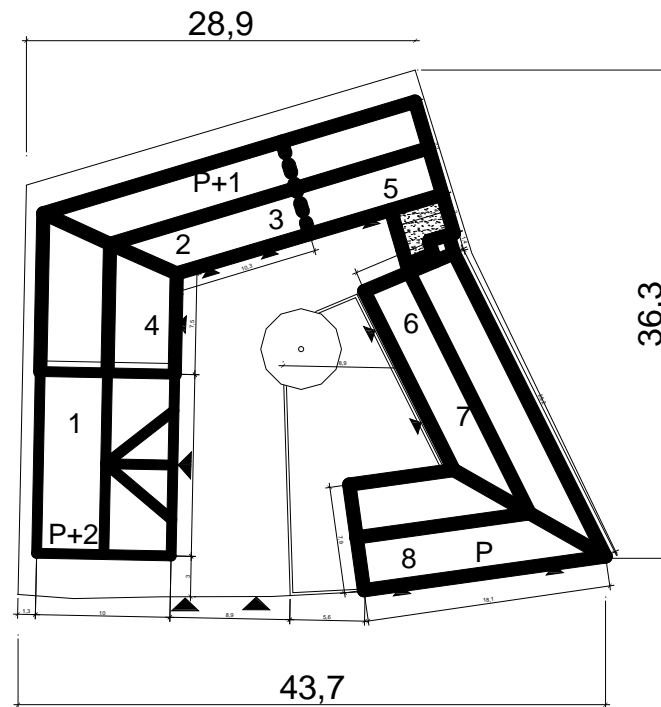

## Cokot

1. STAMBENA KUCA
2. LETNJA KUHINJA
3. GARAŽA
4. MEHANIZACIJA
5. STAJA ZA KRAVE
6. BOKS ZA SVINJE
7. AMBAR
8. LOKAL

# Nepovoljan raspored- zatvoreno-atrijumsko dvorište

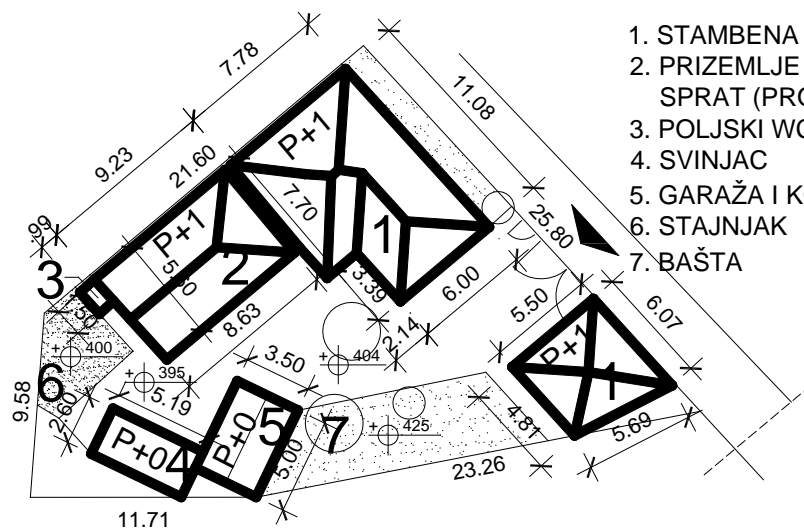
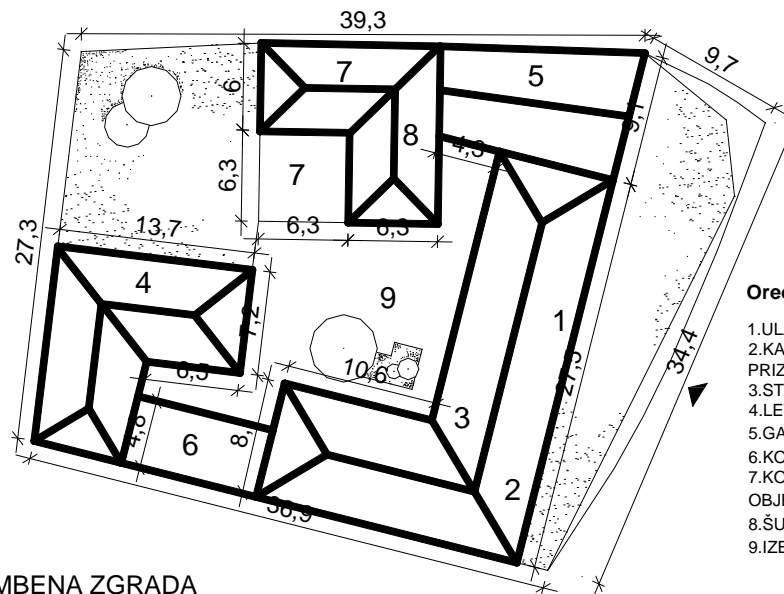

# Nepovoljan raspored- zatvoreno-atrijumsko dvorište

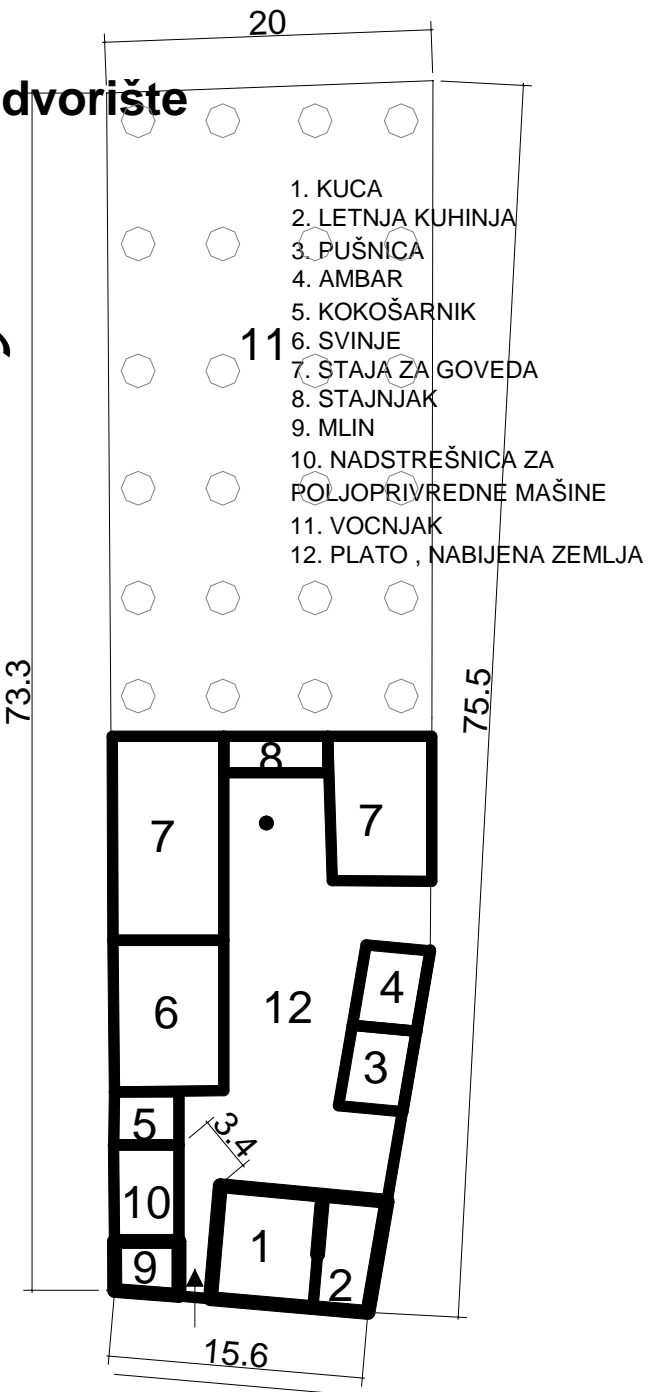
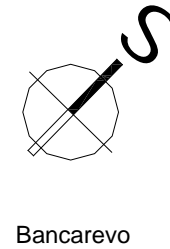
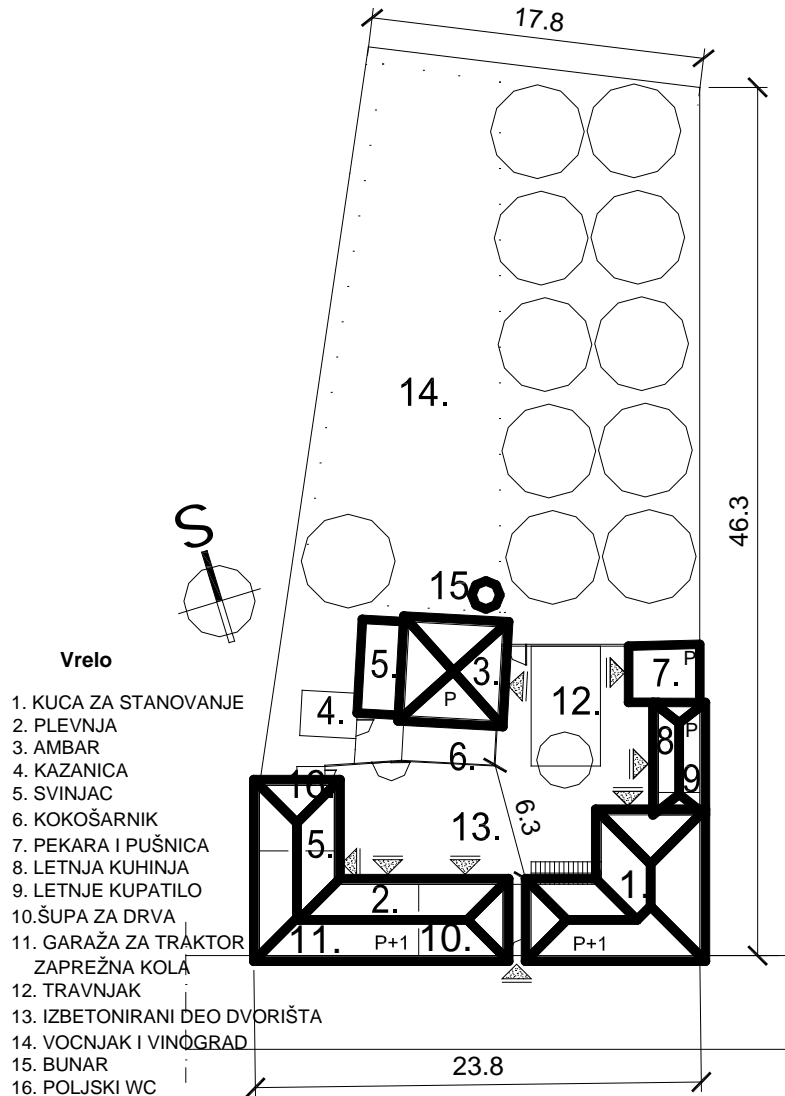



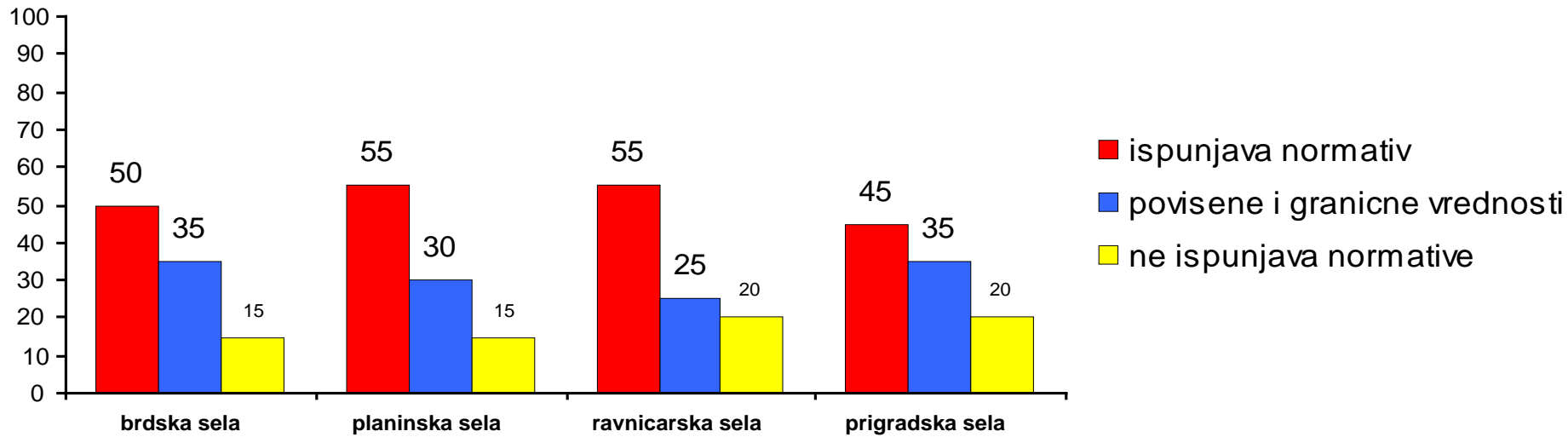

## Koeficijent izgrađenosti

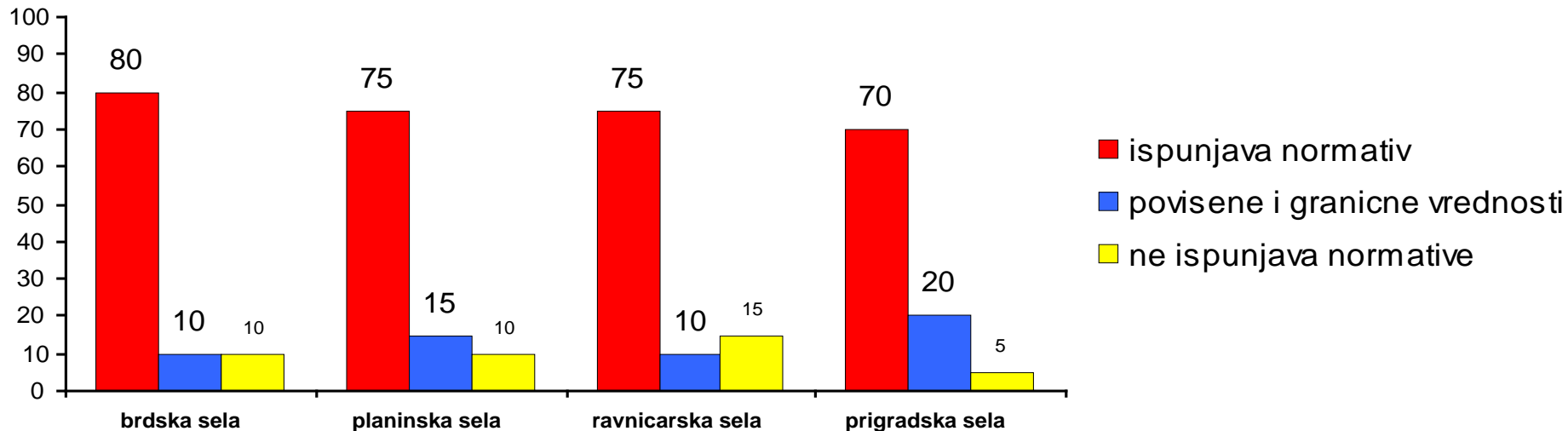

## Koeficijent zauzetosti

koeficijent izgrađenosti za stambenu zonu iznosi 0.15-0.6, a za ekonomsku 0.1-0.8  
 koeficijent zauzetosti za stambenu zonu iznosi maksimum 0.3, a za ekonomsku 0.7  
*Pravilnik o opštim pravilima urbanističke regulacije i parcelacije (članovi 45-79):*

# koeficijent izgrađenosti i zauzetosti-iznad normativa

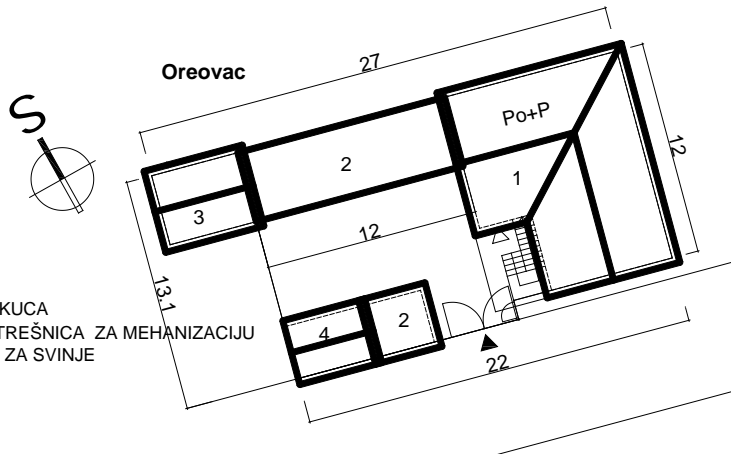

- 1.NOVA KUCA
- 2.NADSTREŠNICA ZA MEHANIZACIJU
- 3.STAJA ZA SVINJE
- 4.ŠUPA

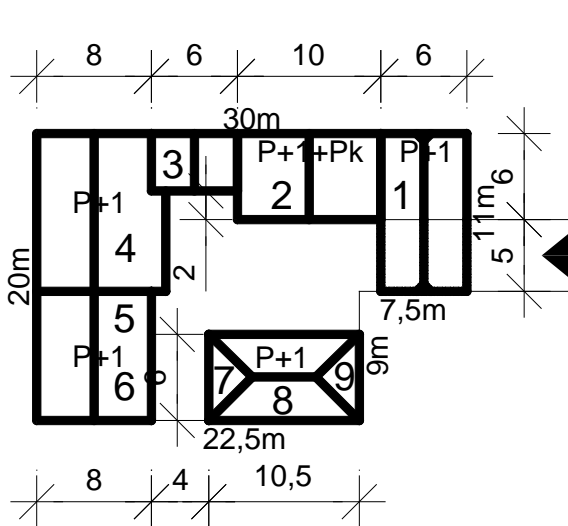

## Hum

- 1.LETNJA KUHINJA
- 2.NOVA KUCA
- 3.PLEVNJA
- 4.NADSTREŠNICA ZA MEHANIZACIJU
- 5.KOKOŠINJAC
- 6.STAJA
- 7.GARAŽA ZA PUTNICKO VOZILO
- 8.KOŠ ZA KUKURUZ
- 9.SKLADIŠTE HRANE

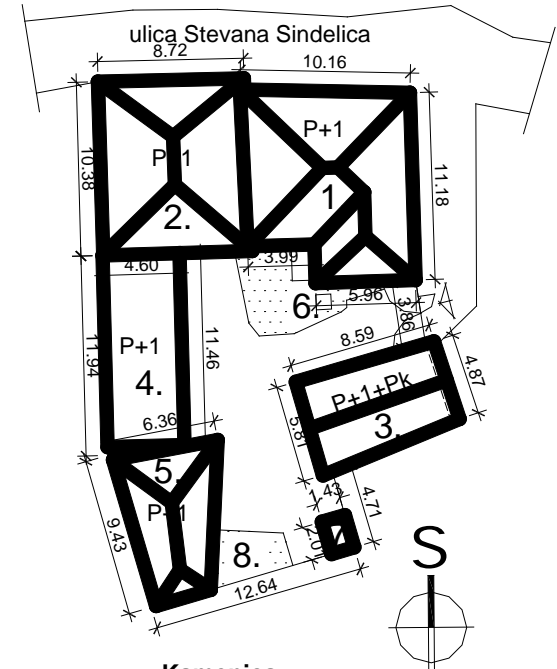

## Kamenica

- 1.STAMBENI OBJEKAT (novi)
- 2.STAMBENI OBJEKAT (stari)
- 3.KOŠ
- 4.GARAŽE
- 5.OSTAVA ZA ORUĐA
- 6.BUNAR
- 7.POLJSKI WC
- 8.STAJNIAK







## Stanje objekata

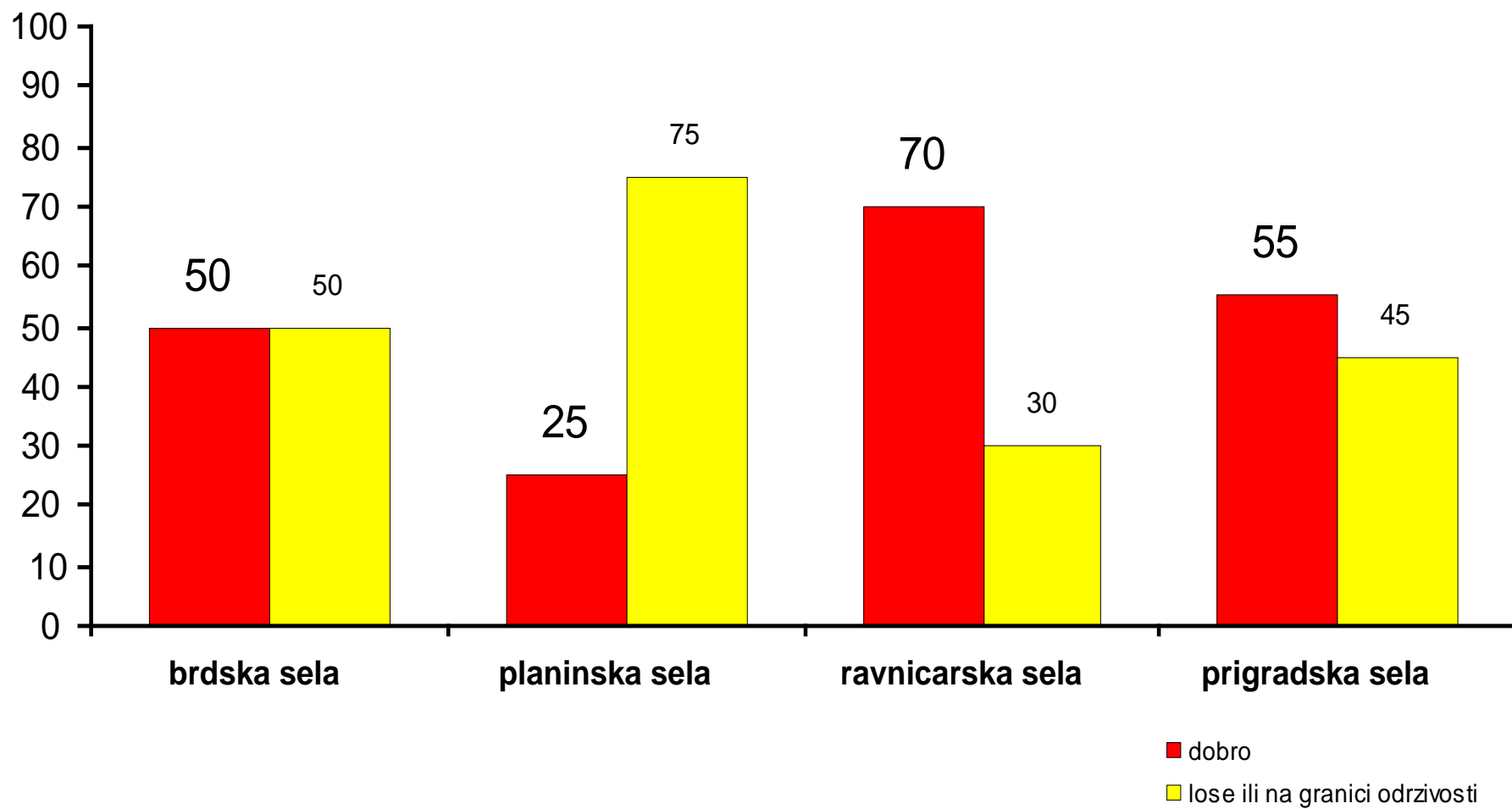













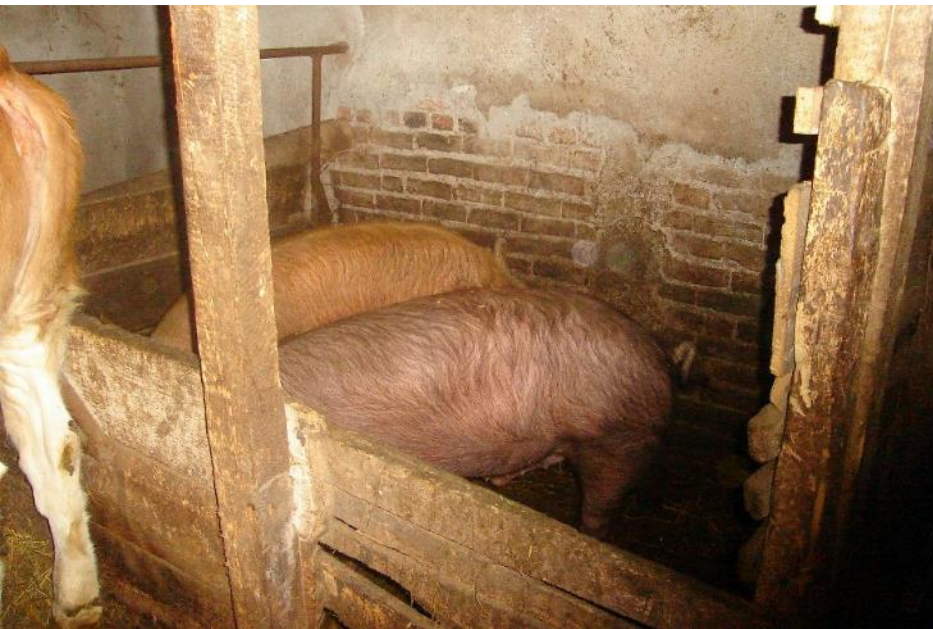



## Stanje uređenosti dvorišta

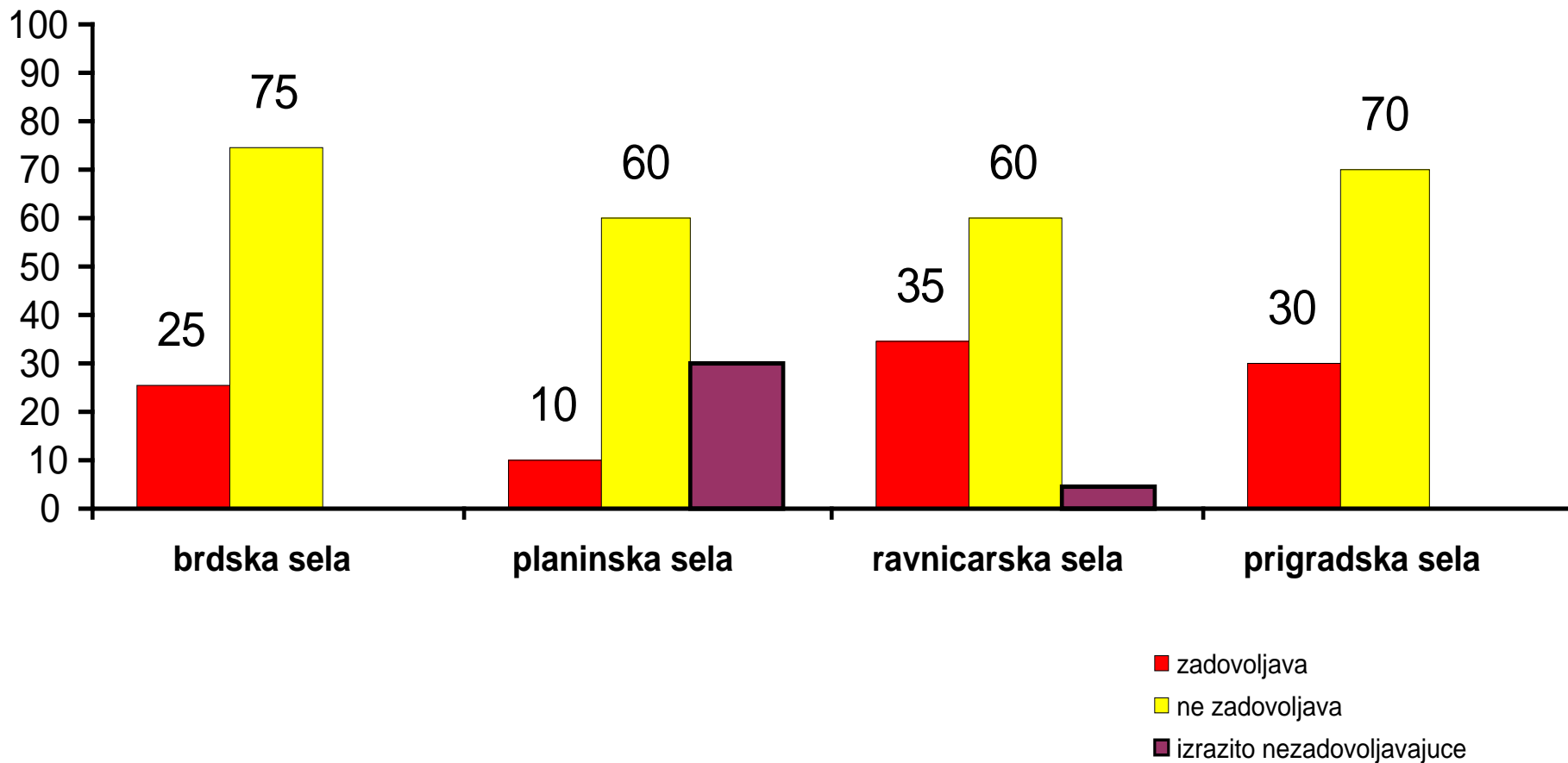















## Opremljenost stambenih objekata komunalnim sistemima

- intenzivno naseljavanje je krenulo pre infrastrukturnog opremanja parcela, spontano i u mnogo većem intenzitetu no što su gradski sistemi i službe mogli da isprate. Iz tog razloga je infrastrukturna opremljenosti i danas dosta loša.
- tek deo domaćinstava ima kanalizacionu mrežu, a ni rešenje odvoženja čvrstog otpada nije rešeno. Jedino su voda, struja i telefon prisutni u svim domaćinstvima.

## brdska sela

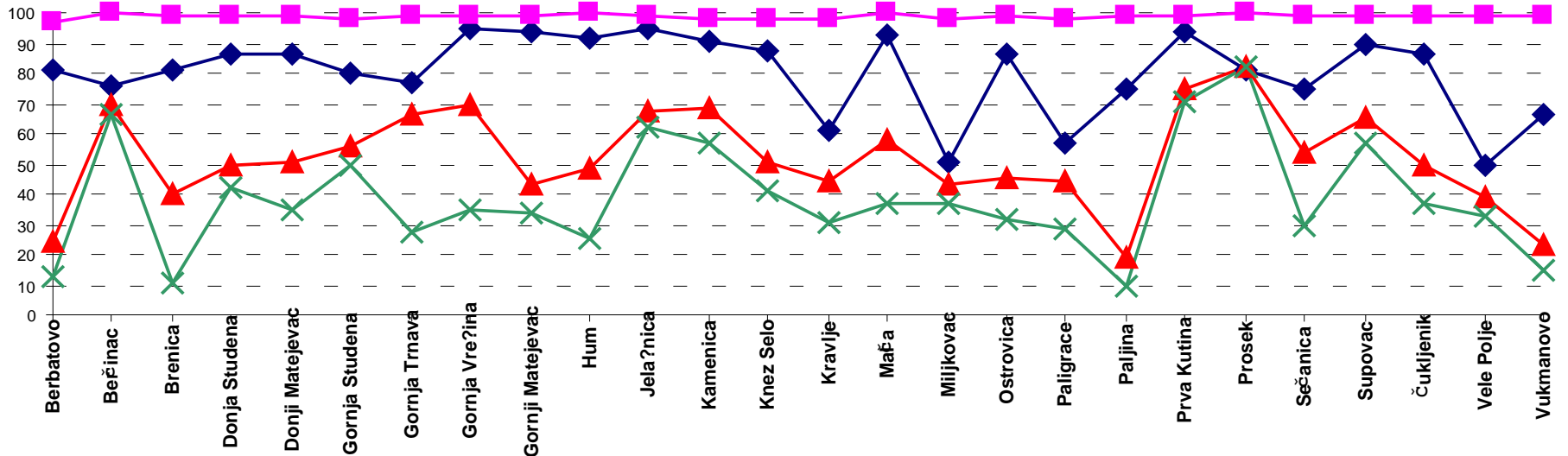

## planinska sela

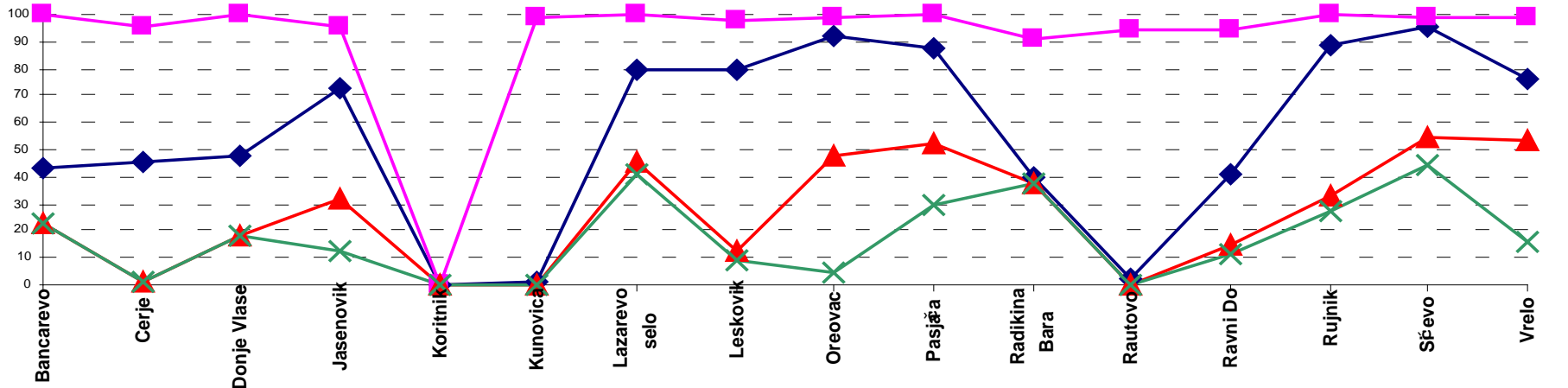

◆ stanovi opremljeni vodom   
 ■ stanovi opremljeni strujom   
 ▲ stanovi sa kupatilom   
 × stanovi sa wc-om

## ravničarsko-moravska sela

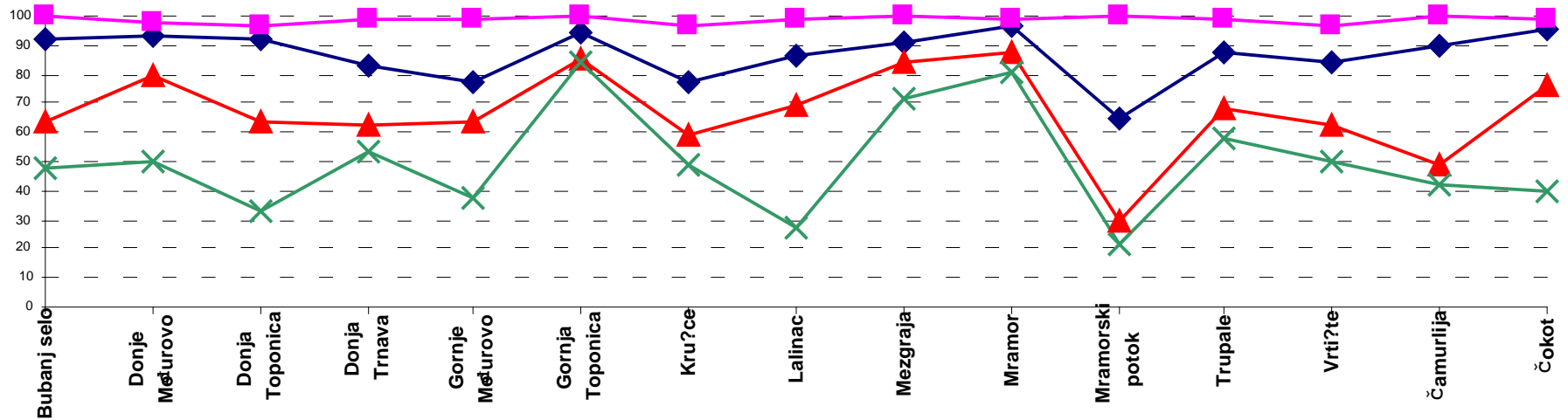

## prigradska sela

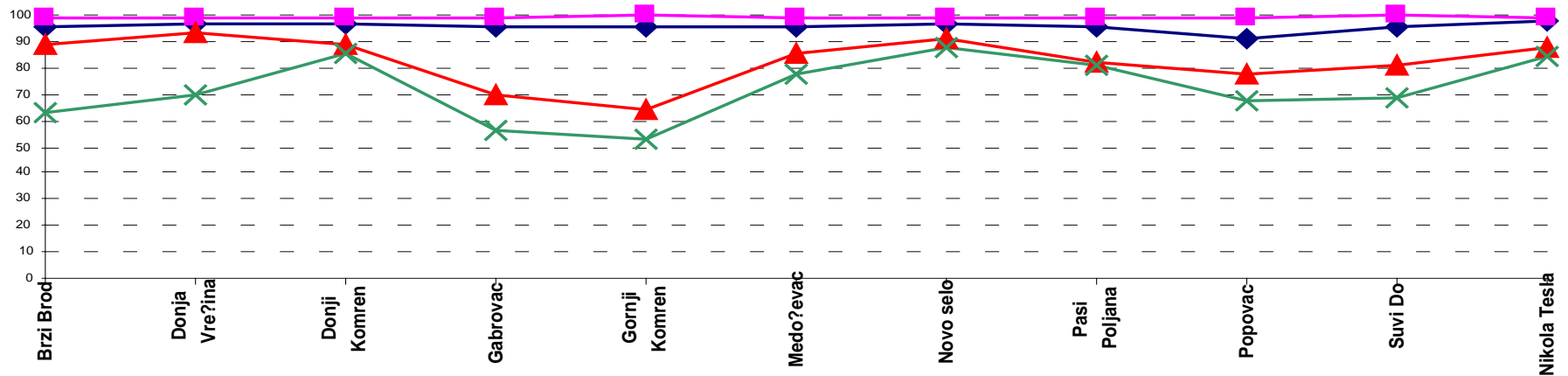

◆ stanovi opremljeni vodom   
 ■ stanovi opremljeni strujom   
 ▲ stanovi sa kupatilom   
 × stanovi sa wc-om

# Održivost domaćinstva u odnosu na starosnu strukturu

(kod sela u kojima su analizirana domaćinstva)

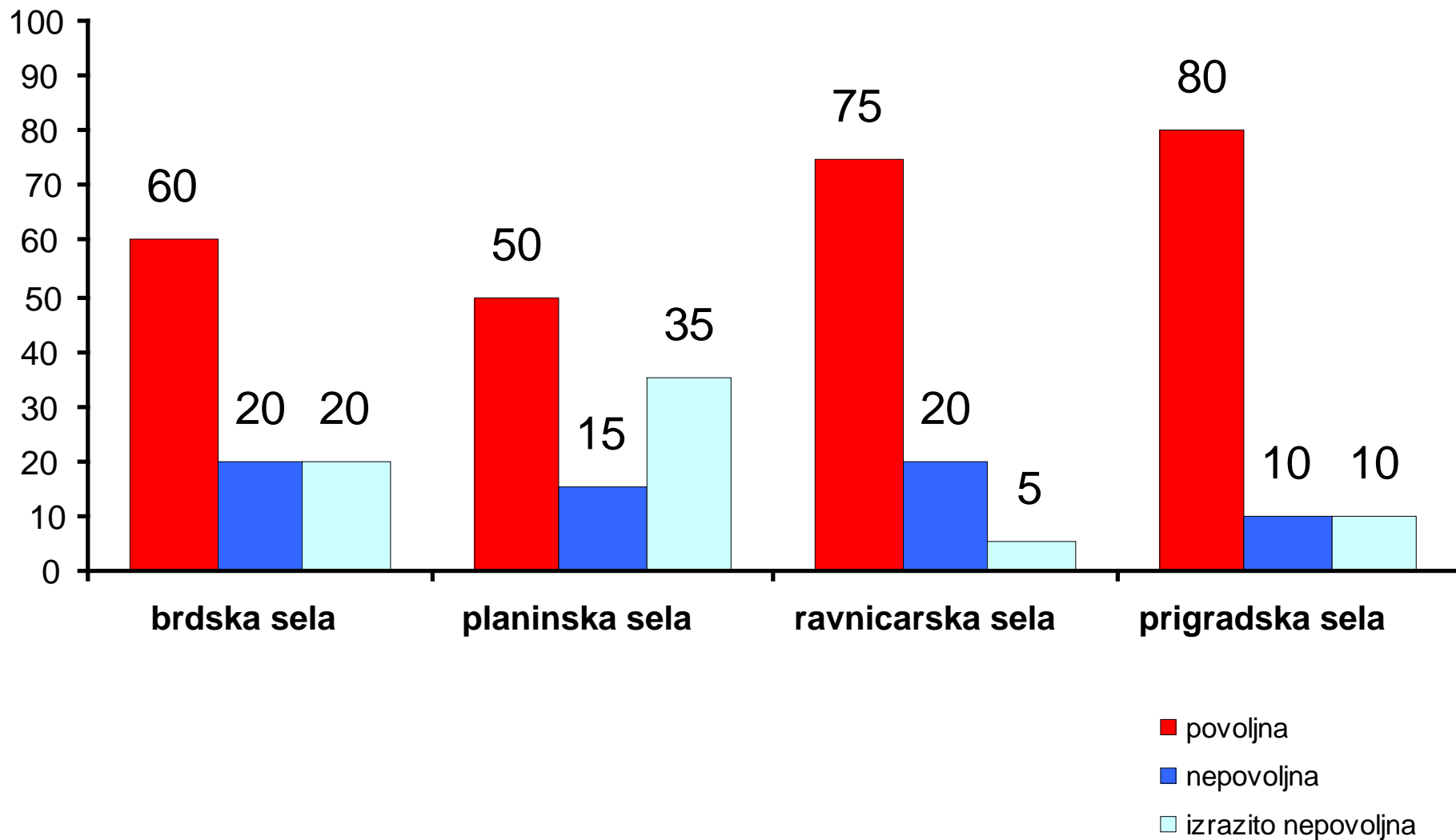



- procesu depopulacije su posebno bila izložena najudaljenija naselja i naselja koja su imala loše saobraćajne veze sa gradom.
- u većini naselja se stabilizovao broj stanovnika i veće promene ne treba očekivati. O tome govori i indeks porasta stanovništva, koji je u oko pedeset posto naselja oko nule ( $\pm 10\%$ , prirast stanovništva), dok je i dalje najugroženiji planinski, ruralniji prostor, gde oko 30% naselja ima negativan priraštaj, što je u skladu sa svim ostalim pokazateljima i tendencijama.
- Na ruralnom prostoru grada ima dvadeset jedno selo sa 300 i manje stanovnika
- Seoska porodica stari i smanjuje se. Na osnovu podataka iz popisa 1948god. prosečna porodica je imala 5-7 članova, dok je po poslednjem popisu to svega oko 3.5.

# Problem depopulacije

