

VII PREDAVANJE

NERAZVOJNE PRAVOIZVODNE JEDNOSTRUKO IZVODNE POVRŠI

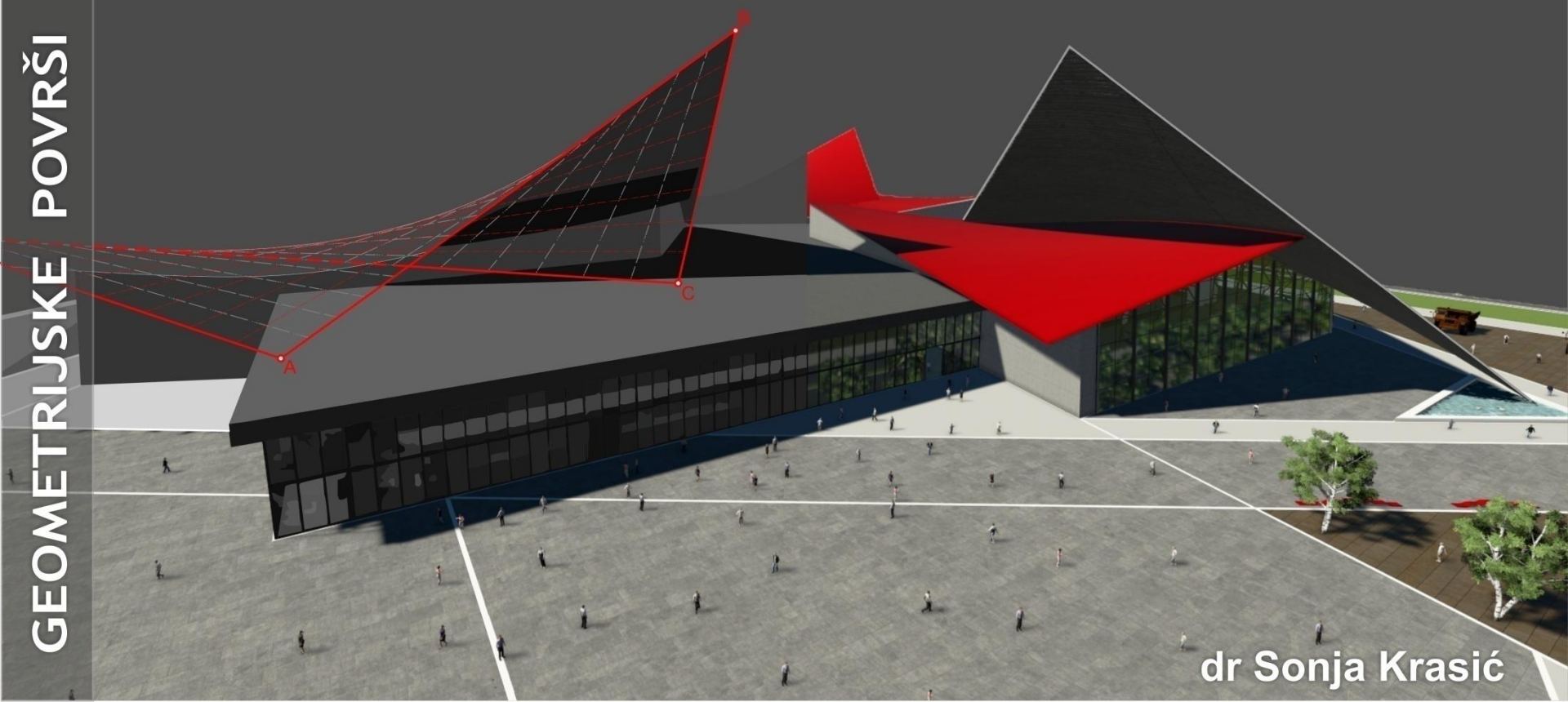



GEOMETRIJSKE POVRŠI U ARHITEKTURI

I PRAVOIZVODNE POVRŠI

I.1. RAZVOJNE:

I.1.1. POLIEDARSKE

I.1.1.1. Pravi poliedri

I.1.1.2. Piramide i prizme

I.1.2. JEDNOSTRUKO-ZAKRIVLJENE

I.1.2.1. Konusi i oblice

I.1.2.2. Konvolutne površi

I.2. NERAZVOJNE:

I.2.1. JEDNOSTRUKO-IZVODNE

I.2.1.1. Helikoidi

I.2.1.2. **Cilindroidi**

I.2.1.3. **Konoidi**

I.2.1.4. **Tetroidi**

I.2.2. DVOSTRUKO-IZVODNE

I.2.2.1. Jednograni obrtni hiperboloid

I.2.2.2. Jednograni eliptični hiperboloid

I.2.2.3. Hiperbolički paraboloid

II DVOSTRUKO ZAKRIVLJENE POVRŠI

II.1. OPŠTE POVRŠI

II.1.1. LOPTA (SFERA)

II.1.2. ELIPSOID

II.1.3. PARABOLOID

II.1.4. DVOGRANI HIPERBOLOID

II.2. OBRTNE POVRŠI

II.2.1. OPŠTE

II.2.2. TORUSI

II.3. KLIZNE (TRANSLACIJSKE) POVRŠI

JEDNOSTRUKO IZVODNE POVRŠI

CILINDROIDI

KONOIDI

TETROIDI



CILINDROIDI

CILINDROIDI

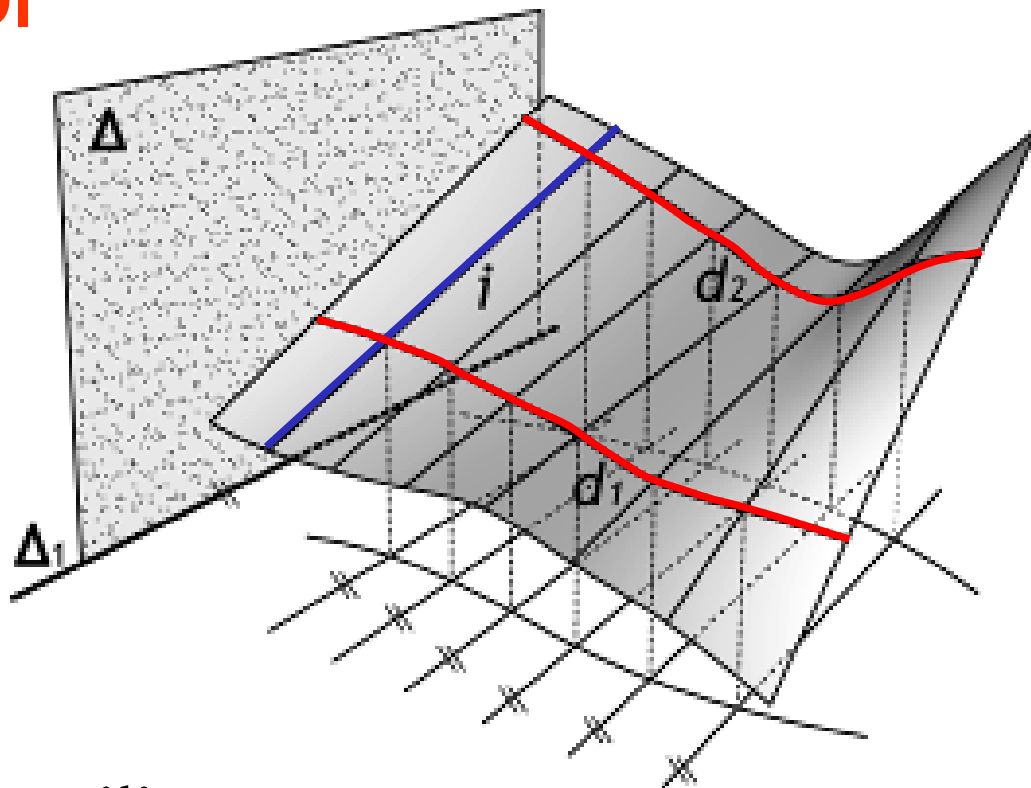

- **vodilje** - dve ravne ili prostorne krive d_1 , d_2 i jedna beskonačno daleka prava b_∞
- **izvodnice** - prave linije i paralelne direktrisnoj ravni Δ

Sl.1

CILINDROIDI

Ravni preseki

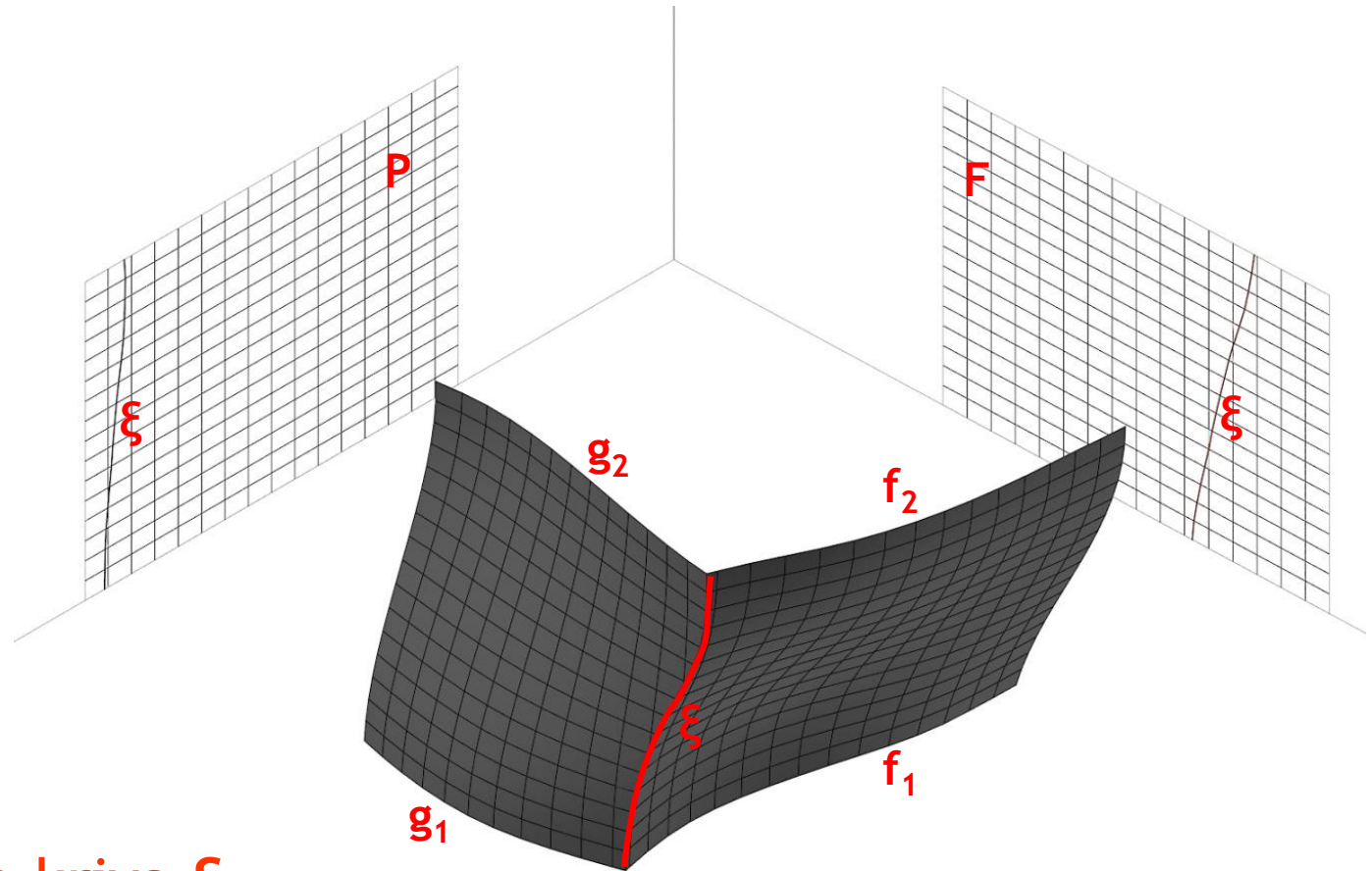

- prostorna kriva ξ - različite direktrise ravni

CILINDROIDI

Ravni preseki

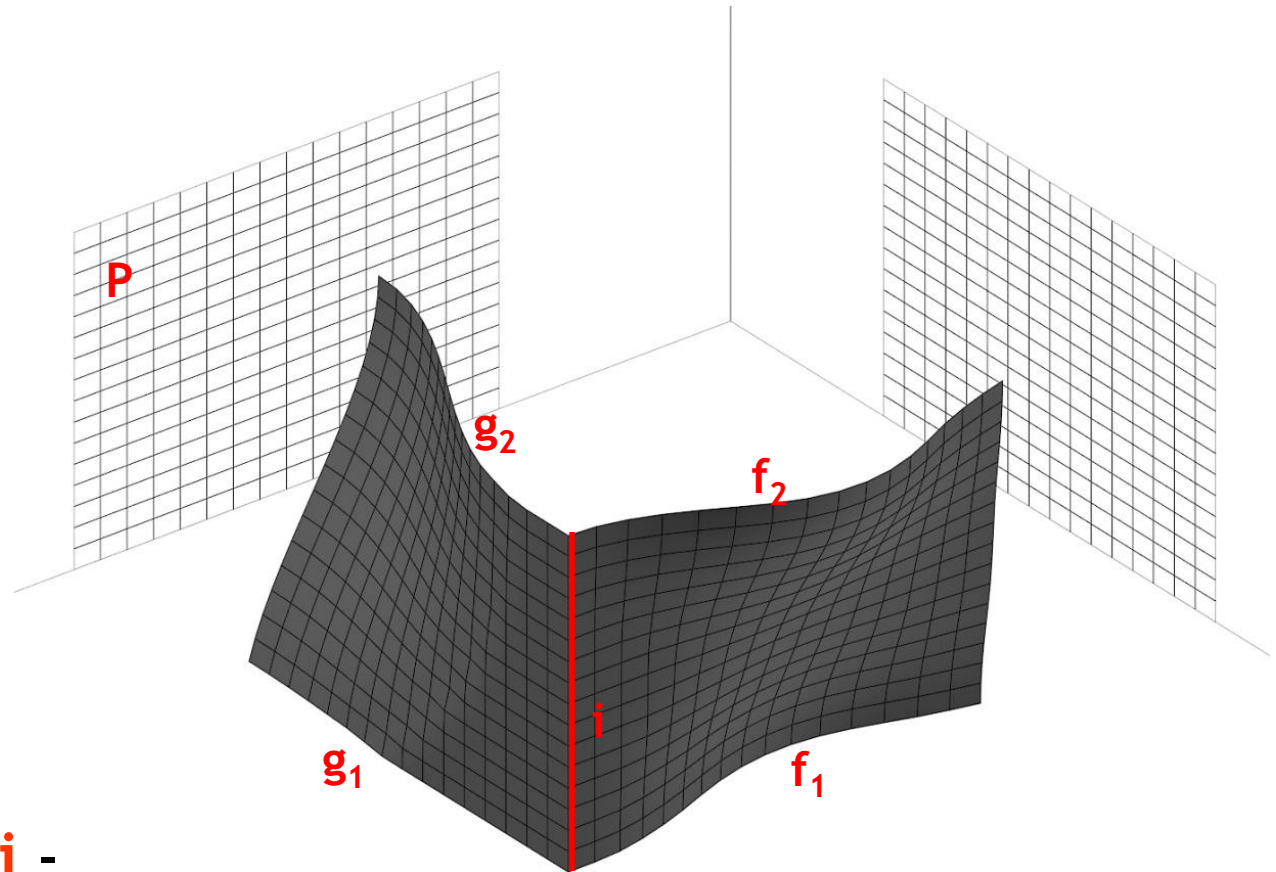

- prava linija i - iste direktrise ravni

CILINDROIDI

aksonometrija

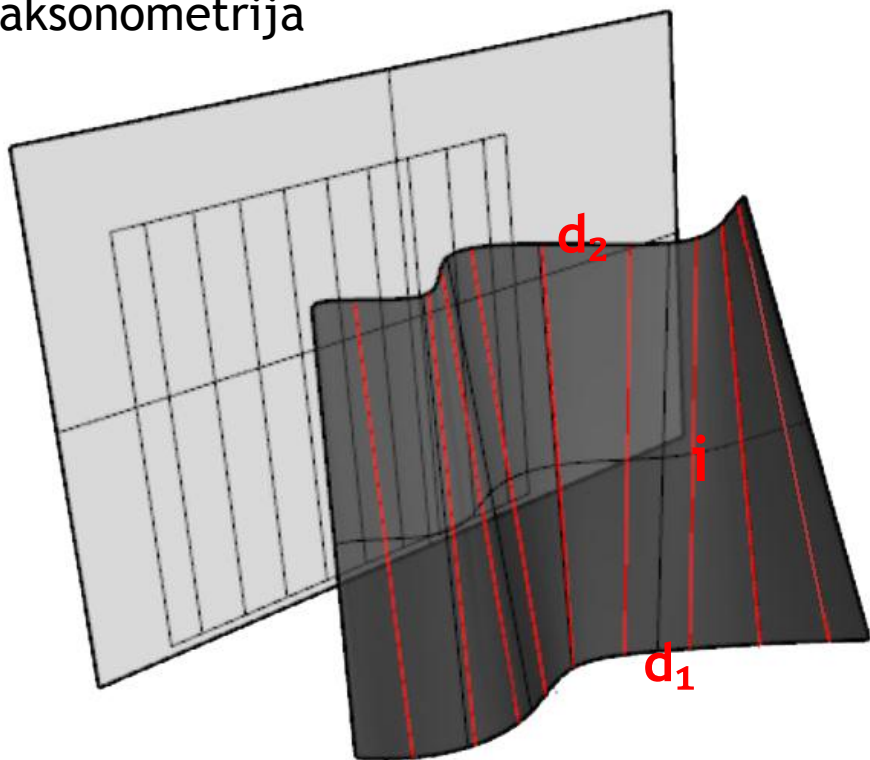

- **vodilje** - dve ravne krive d_1 , d_2
i beskonačno daleka prava b_∞
- **izvodnice** - prave linije i

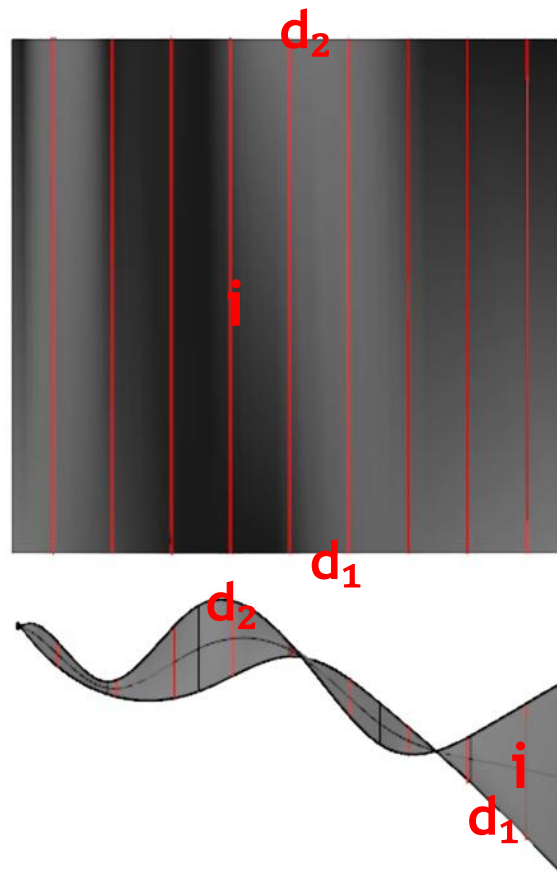

osnova i izgled

CILINDROIDI

aksonometrija

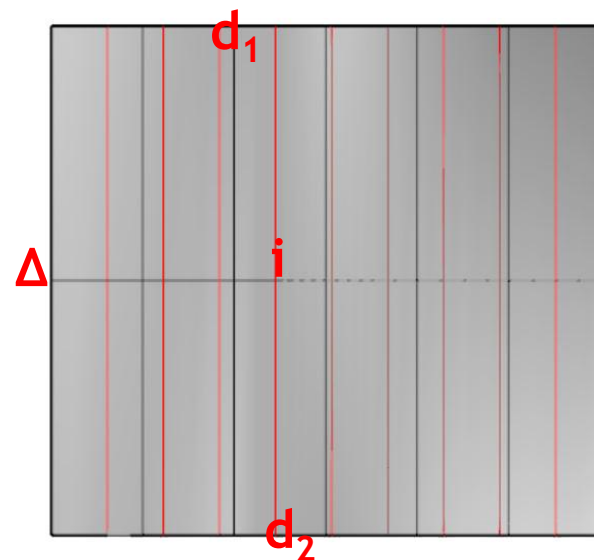
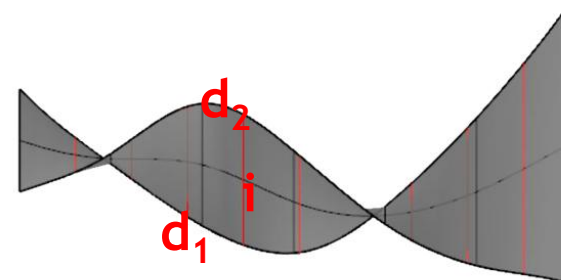
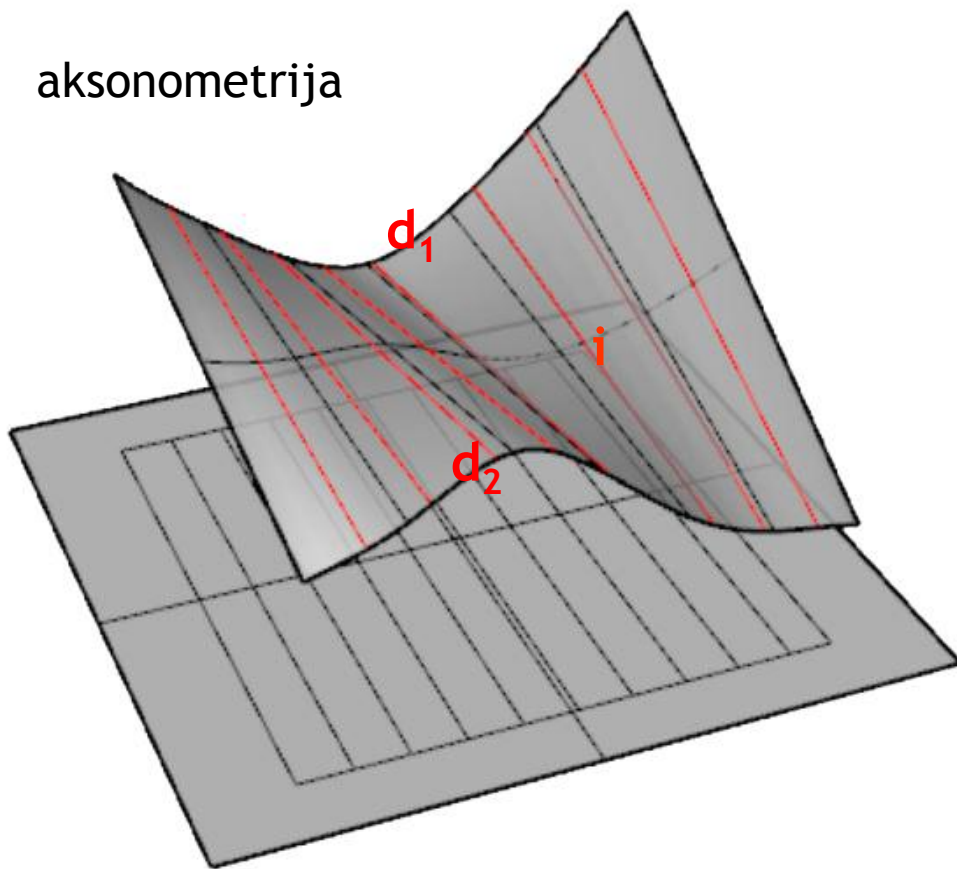

osnova i izgled

- **vodilje** - dve ravne krive d_1 , d_2 i beskonačno daleka prava b_∞
- **izvodnice** - prave linije i

CILINDROIDI

aksonometrija

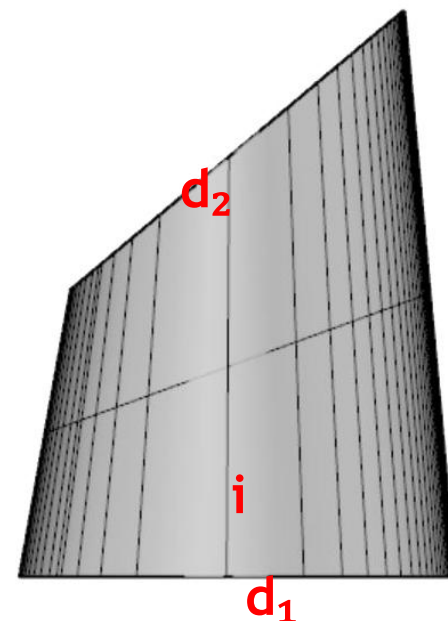
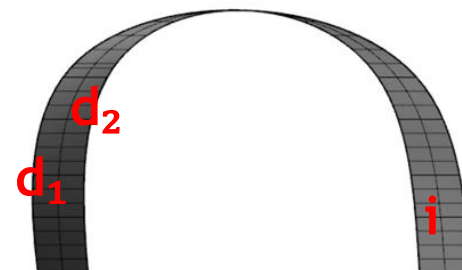
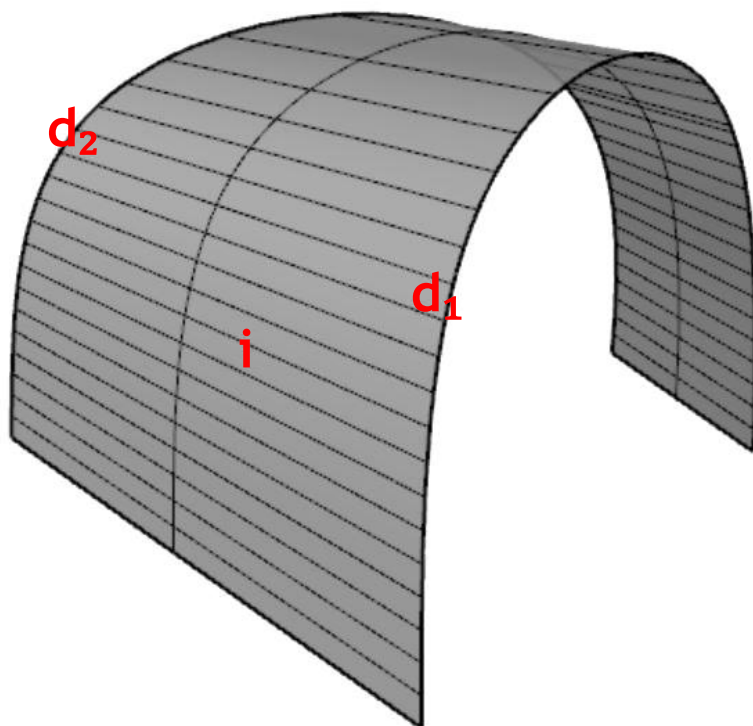

osnova i izgled

- **vodilje** - dve ravne krive d_1 , d_2
i beskonačno daleka prava b_∞
- **izvodnice** - prave linije i

CILINDROIDI

aksonometrija

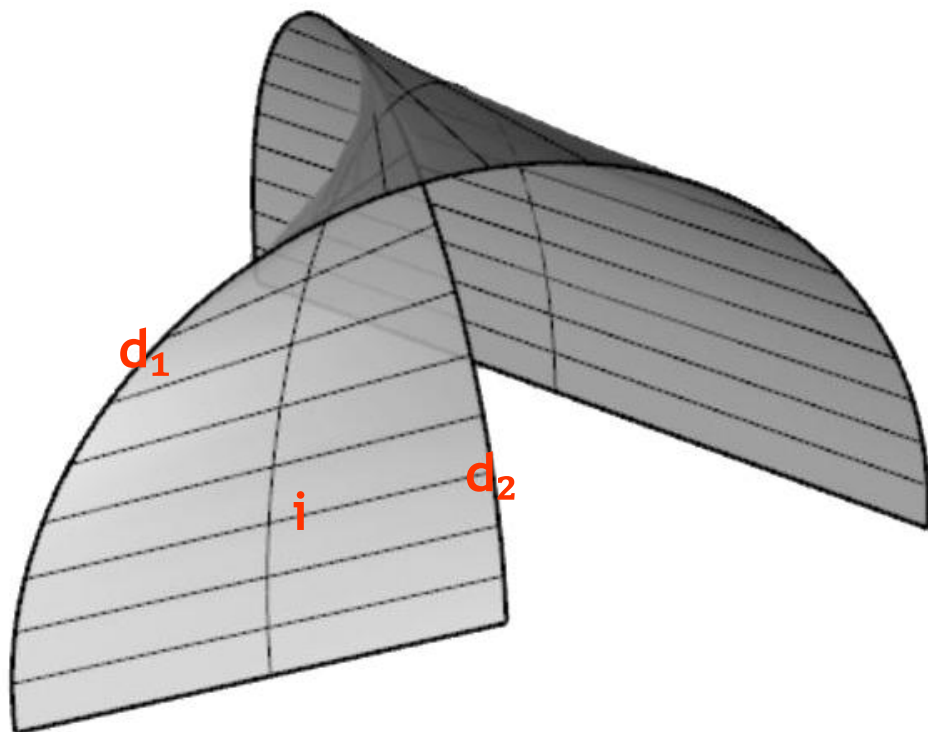

- **vodilje** - dve ravne krive d_1 , d_2
i beskonačno daleka prava b_∞
- **izvodnice** - prave linije i

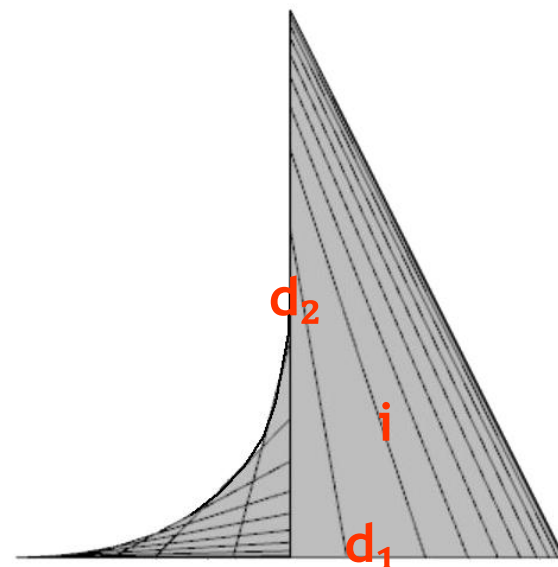
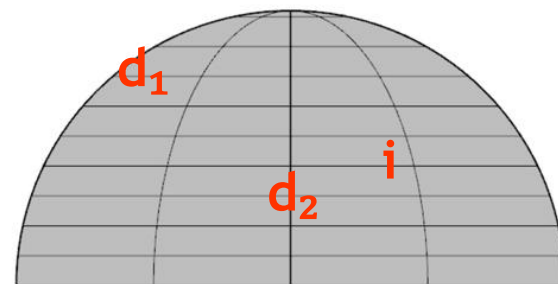

osnova i izgled

CILINDROIDI

aksonometrija

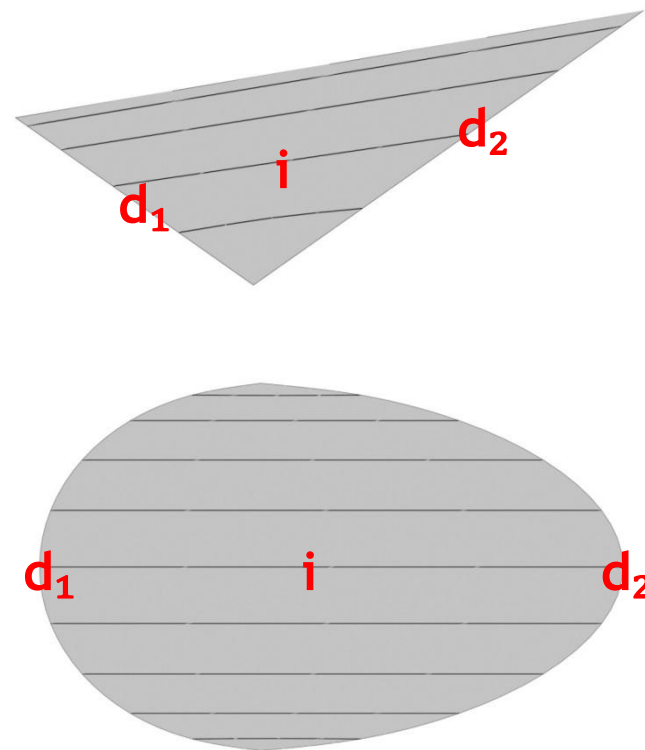
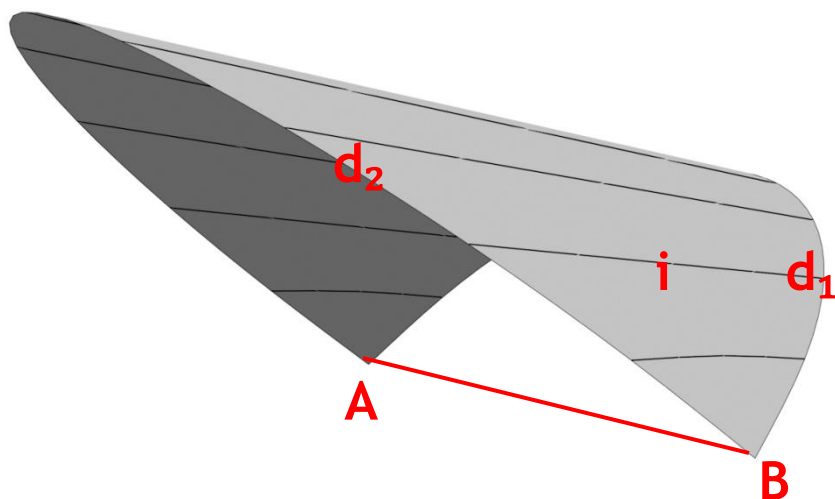

osnova i izgled

- **vodilje** - dve ravne krive d_1 , d_2 i beskonačno daleka prava b_∞
- **izvodnice** - prave linije i

CILINDROIDI

Transformacija cilindra u cilindroid

<p>A1</p>	<p>A2</p>	<p>A3</p>	<p>A</p>	<p>CILINDAR</p>		
<p>B1</p>	<p>B2</p>	<p>B3</p>			<p>B</p>	<p>CILINDROID</p>
<p>C1</p>	<p>C2</p>	<p>C3</p>				

CILINDROIDI

Transformacija cilindroida u cilindar

<p>D1</p>	<p>D2</p>	<p>D3</p>	D	CILINDROID		
<p>E1</p>	<p>E2</p>	<p>E3</p>			E	CILINDROID
<p>F1</p>	<p>F2</p>	<p>F3</p>				

PRIMENA CILINDROIDA U ARHITEKTURI



Primena cilindroida u arhitekturi



Kapela Notr Dam, Ronšamp, Francuska, arh. Le Corbusier, 1955.g

Primena cilindroida u arhitekturi



Umetnička galerija, Ontario, Kanada, arh. F.O. Gehry, 2006.g

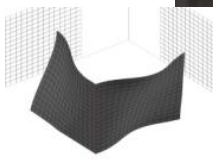

Koncertna hala Dizni, Los Angeles, SAD, arh. F.O.Geri, 2003.g

Primena cilindroida u arhitekturi



Gugenhajmov muzej, Bilbao, Španija, arhitekta F.O.Geri, 1997.g



Primena cilindroida u arhitekturi



Lou Ruvo Centar za moždane bolesti, Klivlend, SAD, F.O. Gehry,
2009.g



Peter B Lewis zgrada, Case Western Reserve Univerzitet, Masačusets, SAD, arh. F.O. Gehry, 2002.g

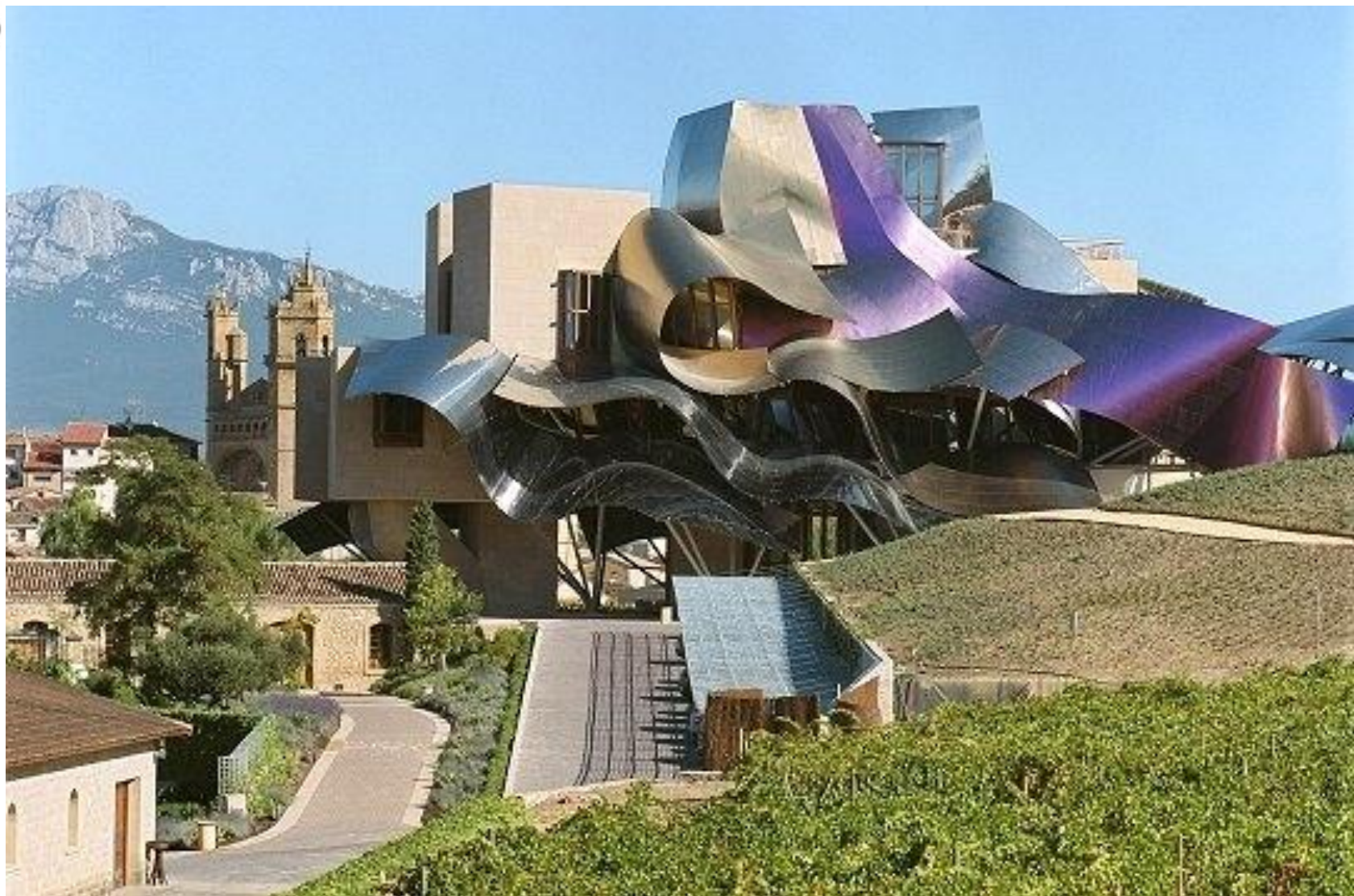

Markes De Riskal Hotel, Elciego, Španija, arh. F.O. Gehry, 2006.g

Primena cilindroida u arhitekturi



Markes De Riskal Hotel, Elciego, Španija, arh. F.O. Gehry, 2006.g



Sedište kompanije IAC, Nju Jork, SAD, arh. F.O.Gehry, 2007.g



Primena cilindroida u arhitekturi



Novy Zolhof, Dizeldorf, Nemačka, arh. F. O. Gehry, 1998.g

Primena cilindroida u arhitekturi



Vitra Centar, Basel-Birsfelden, Švajcarska, arh. F.O. Gehry,
1994.g



'MARTa' muzej, Herford, Nemačka, arh. F.O. Gehry, 2005.g

Primena cilindroida u arhitekturi



Umetnička galerija u Alberti, Edmonton, Kanada, arh. Randall Stout Architects, 2010.g

Primena cilindroida u arhitekturi

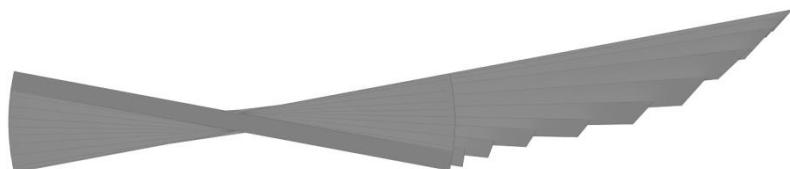

presek kroz centralni deo objekta

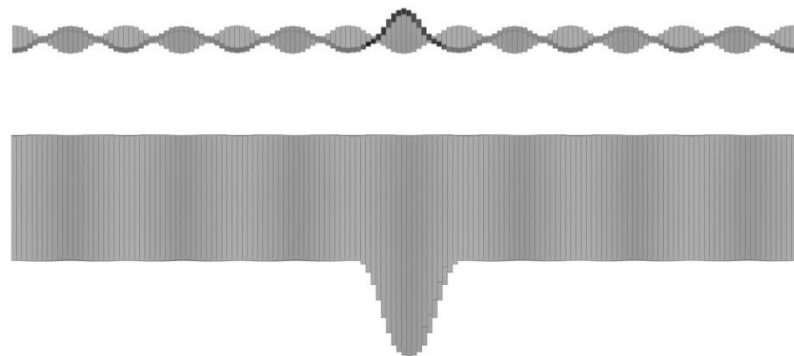

osnova i izgled

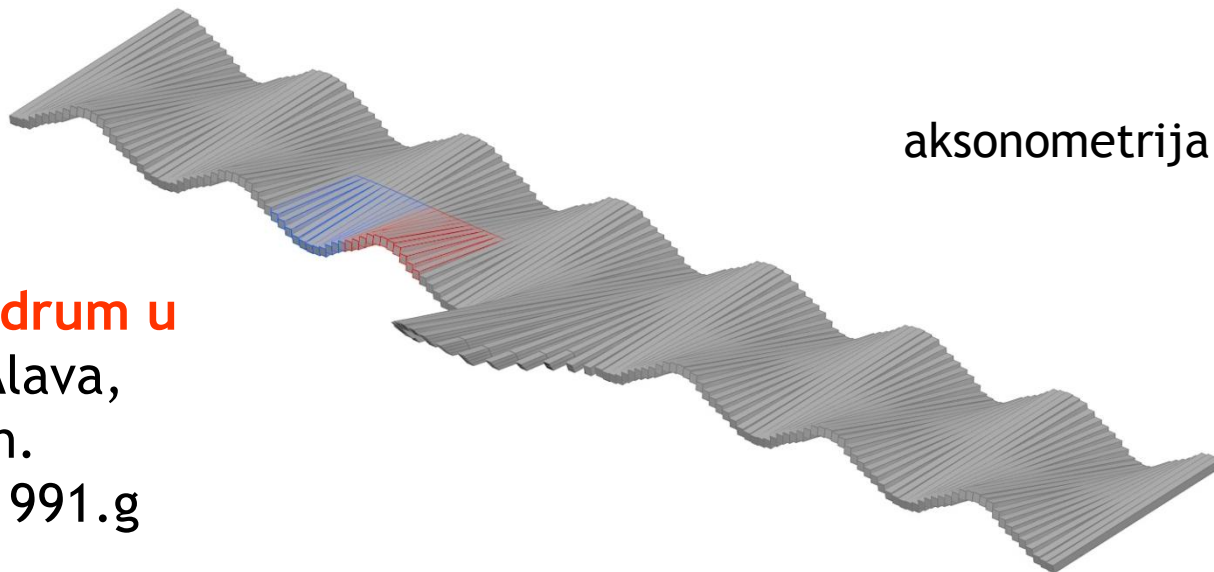

aksonometrija

**Ysios vinski podrum u
Laguardiji, Álava,
Spain, arh.
S.Calatrava, 1991.g**

Primena cilindroida u arhitekturi

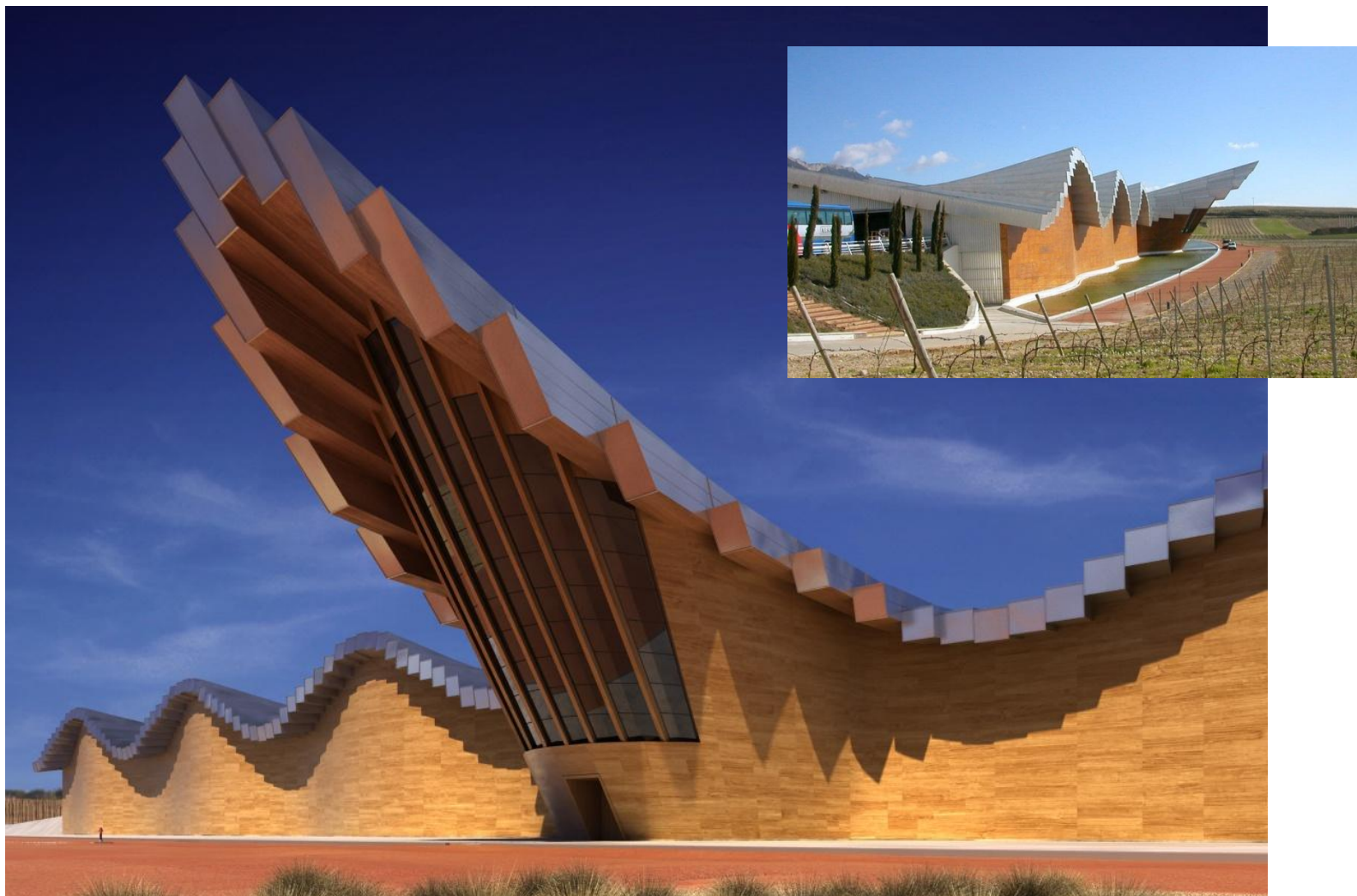

Ysios vinski podrum u Laguardiji, Álava, Spain, arh. S.Calatrava,
1991.g



Primena cilindroida u arhitekturi

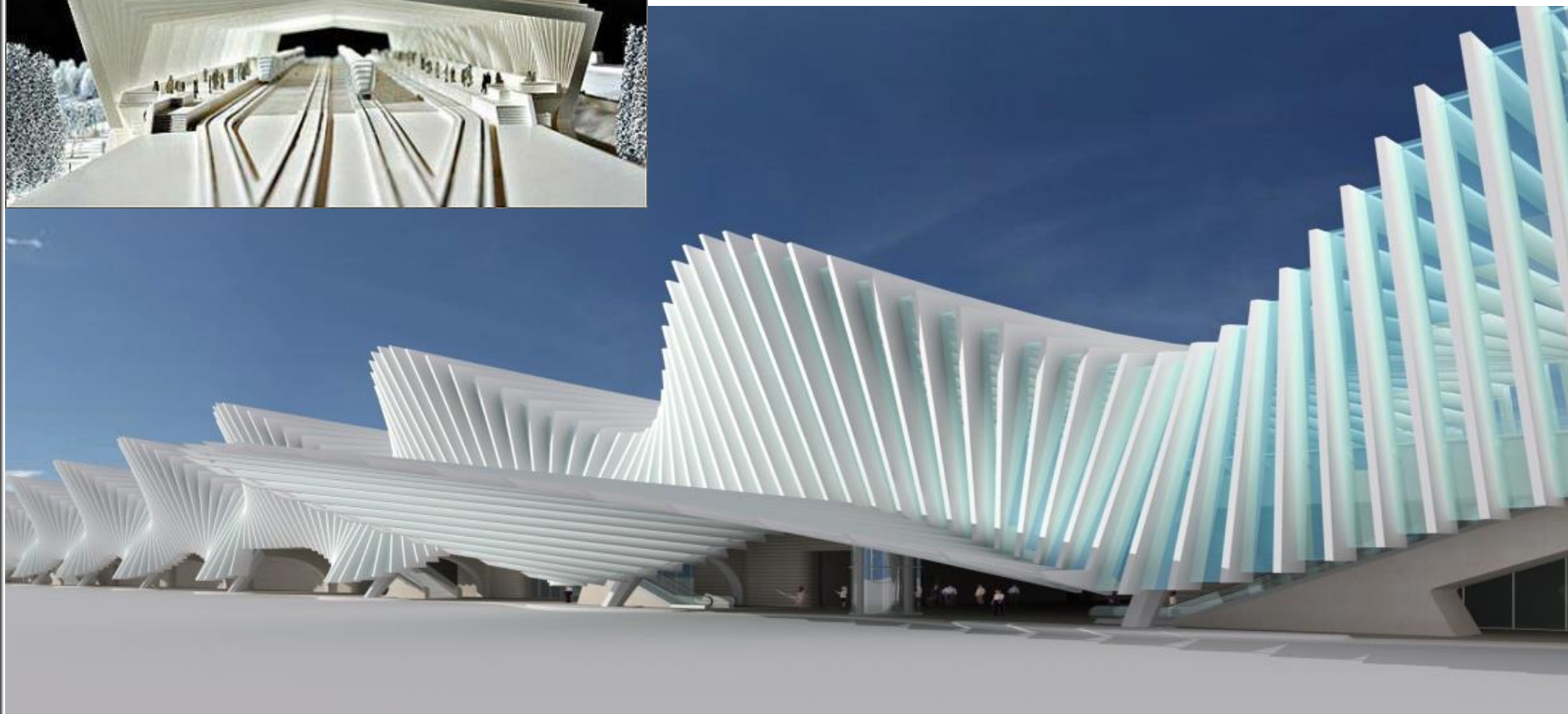

Železnička stanica, Reggio Emilia, Italija, arh. S. Calatrava, 2010.g



Ingalls hokejaška dvorana Yale univerziteta, Nju Heven, Konektikat,
SAD, arh. Eero Saarinen, 1958.g



Ingalls hokejaška dvorana Yale univerziteta, Nju Heven, Konektikat,
SAD, arh. Eero Saarinen, 1958.g

Primena cilindroida u arhitekturi

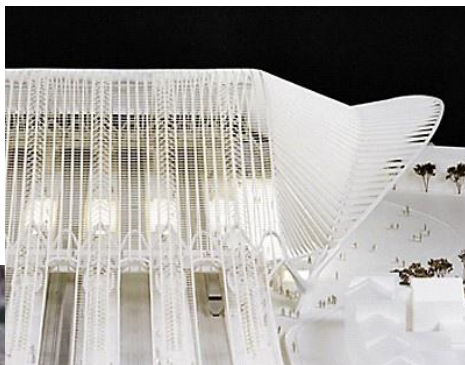

Liège Guillemins TGV stanica, Lijež, Belgija, arh.S. Calatrava,
2009.g

CILINDROIDI

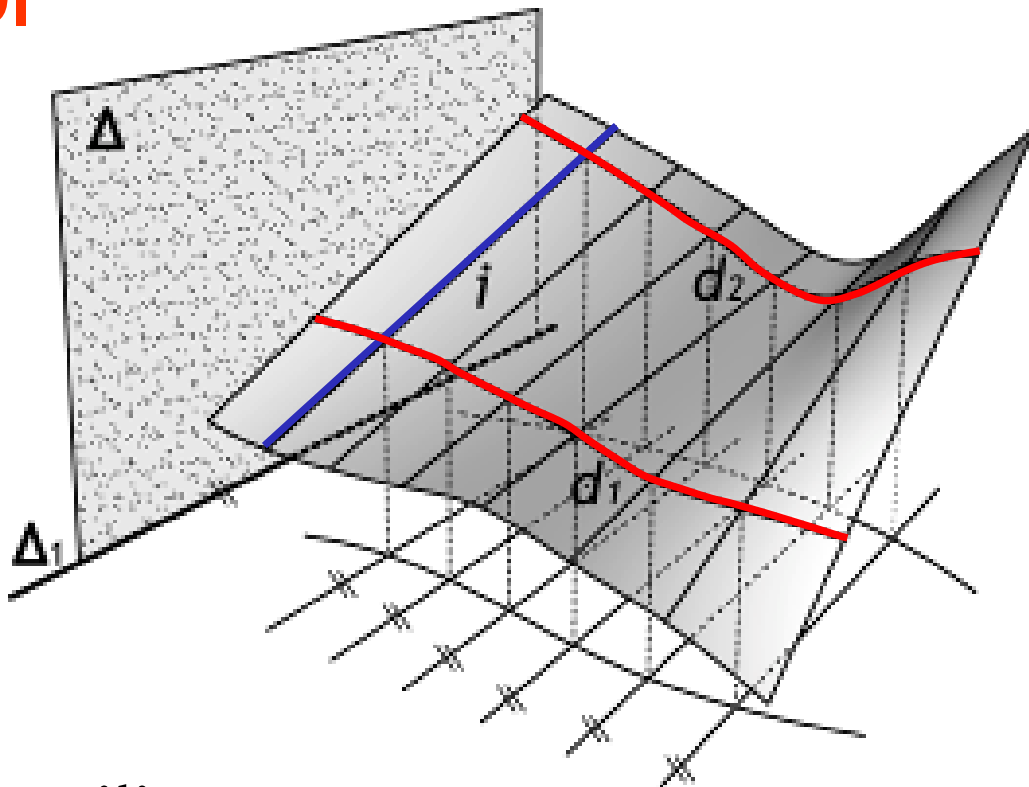

- **vodilje** - dve ravne ili prostorne krive d_1 , d_2 i jedna beskonačno daleka prava b_∞
- **izvodnice** - prave linije i paralelne direktrisnoj ravni Δ

Sl.1



KONOIDI

KONOIDI

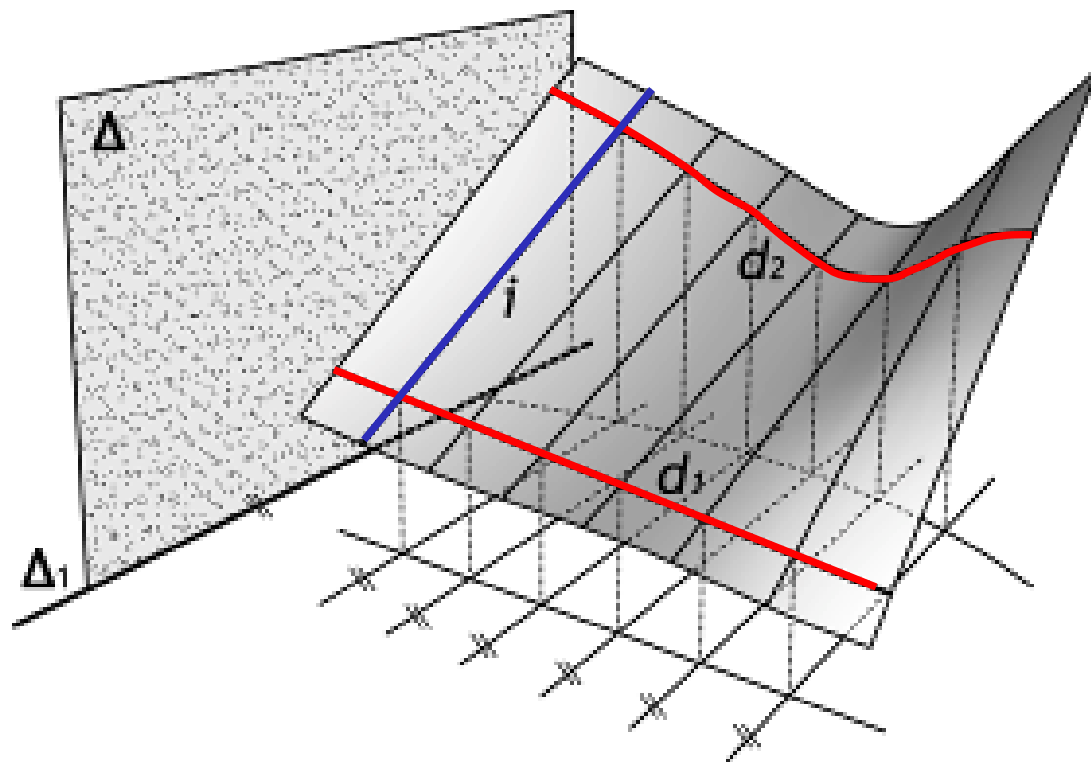

- **vodilje** - jedna prava u konačnosti d_1 , jedna beskonačno daleka prava b_∞ i jedna ravna ili prostorna kriva d_2
- **izvodnice** - prave linije i paralelne direktrisnoj ravni Δ

Sl.1

KONOIDI

Ravni preseki

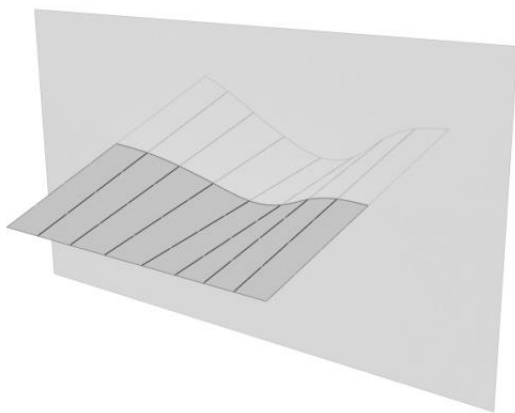

Sl.1

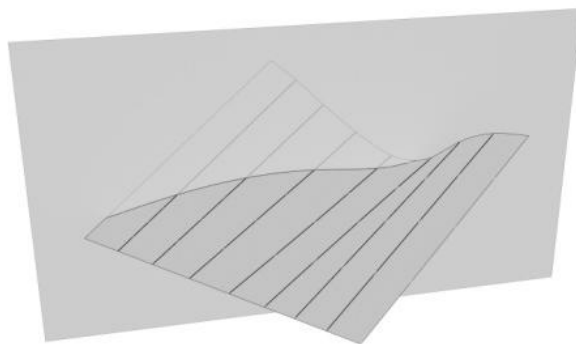

Sl.2

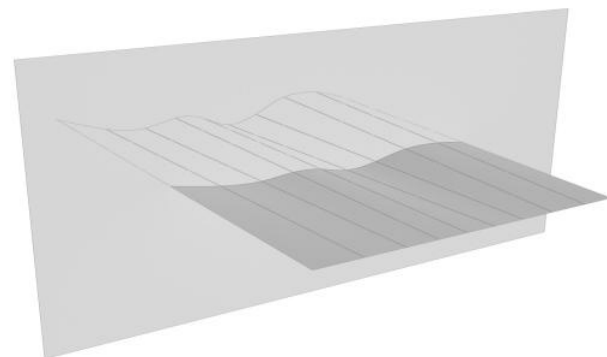

Sl.3

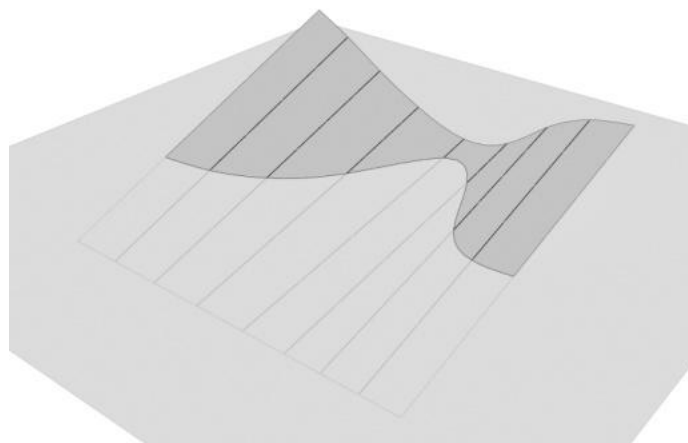

Sl.4

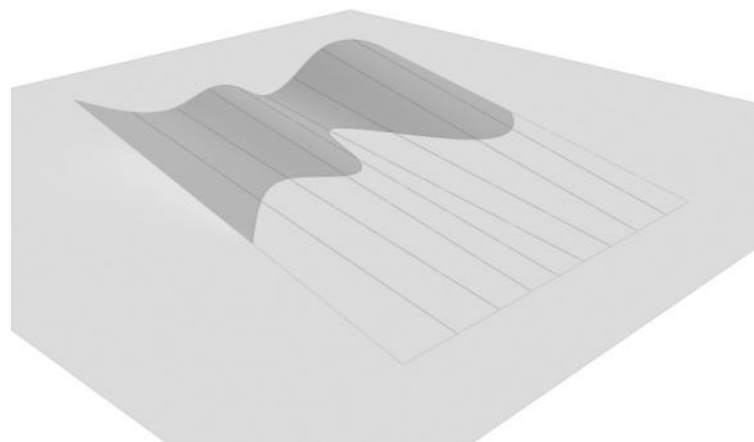

Sl.5

KONOIDI

Ravni presecki

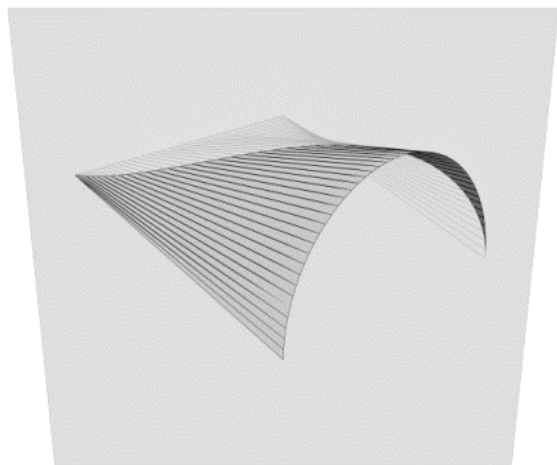

Sl.1

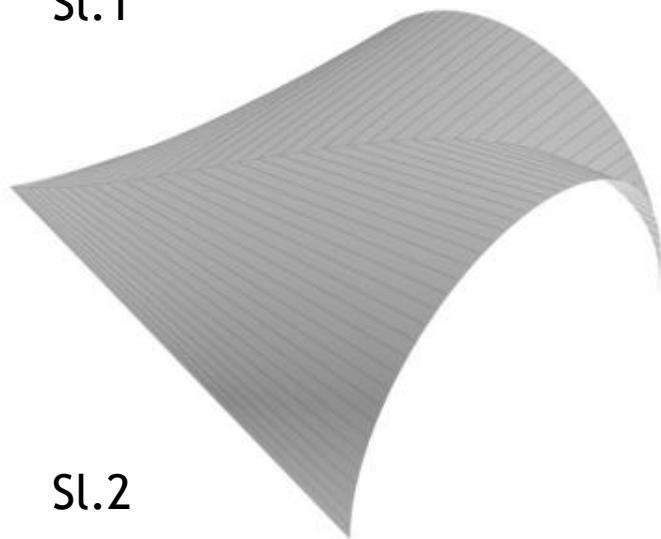

Sl.2

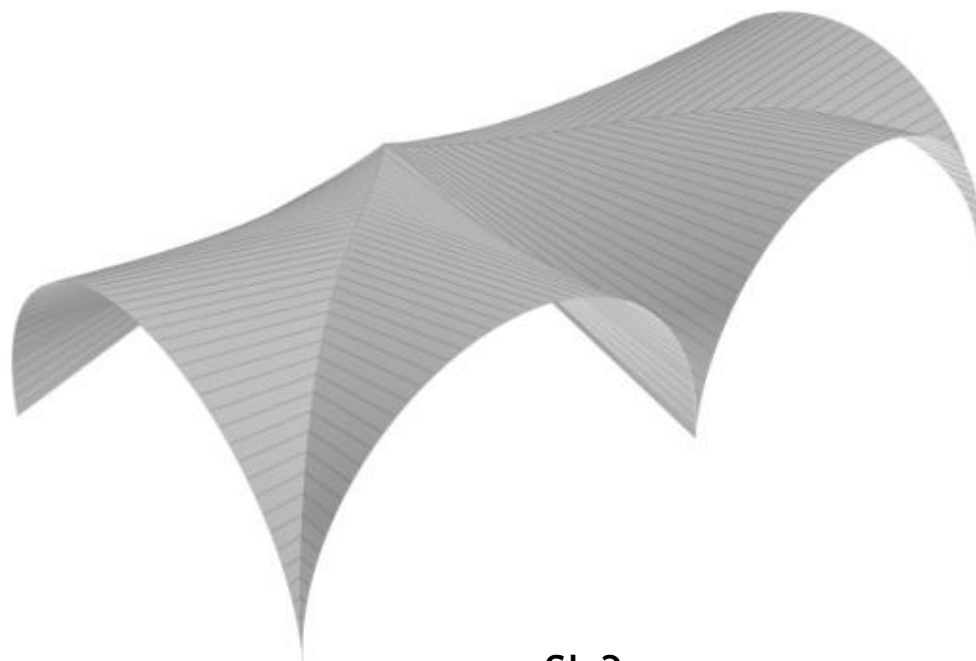

Sl.3

osnova kvadrat

KONOIDI

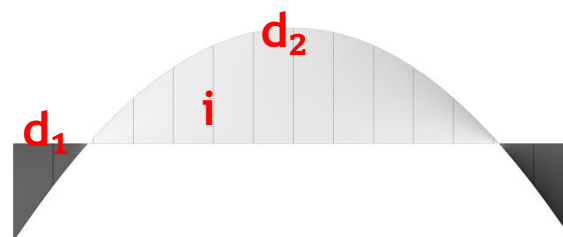
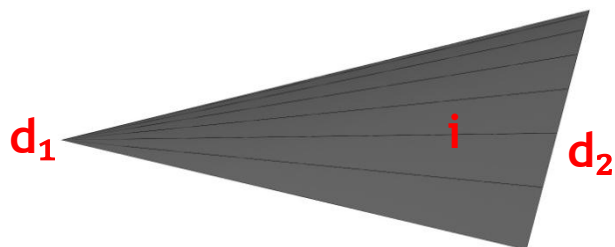

- **vodilje** - prave d_1 , $b\infty$ i parabola d_2
- **izvodnice** - prave linije i

aksonometrija

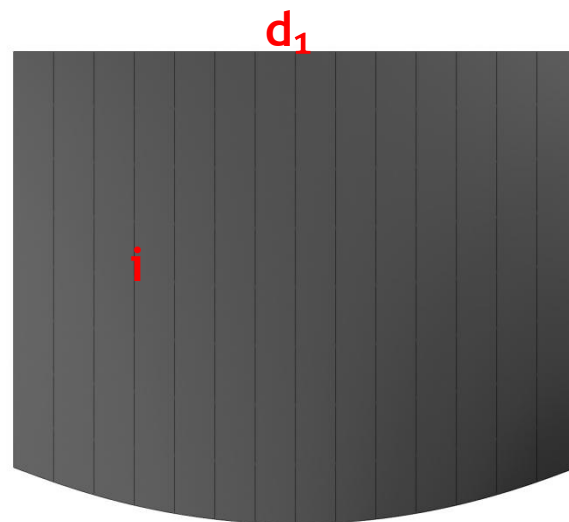

osnova i izgledi

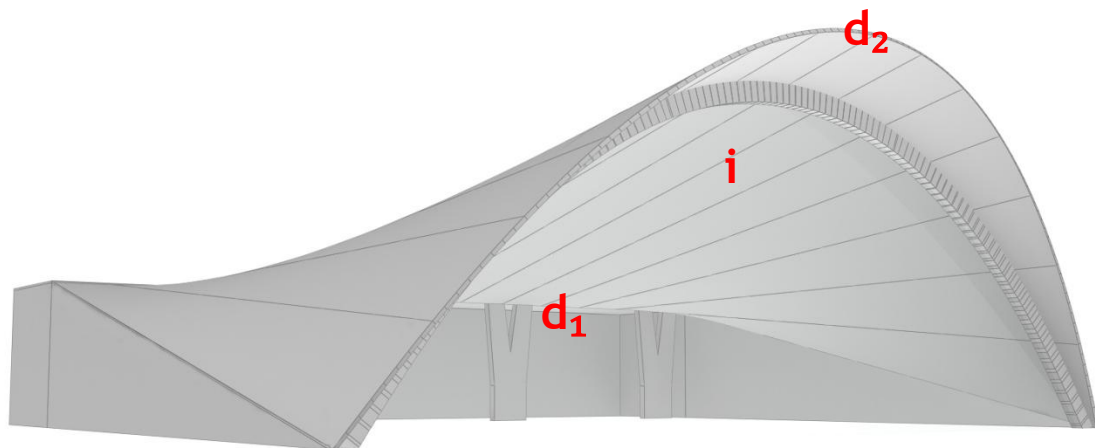

KONOIDI

- **vodilje** - prave d_1 , $b\infty$ i kružnica d_2
- **izvodnice** - prave linije i

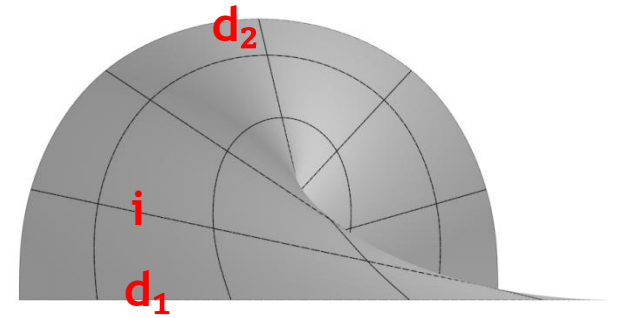

facade

axonometry

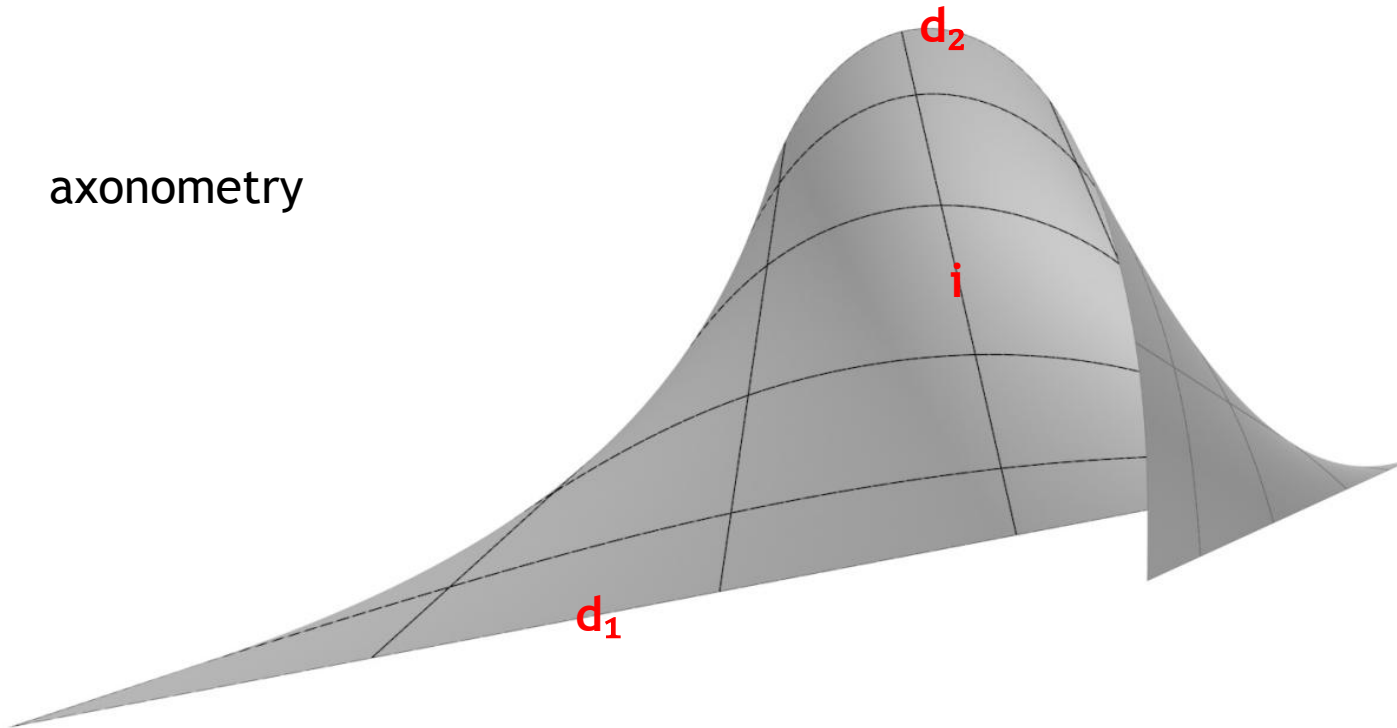

KONOIDI

- **vodilje** - prave $d_1(e)$, b_∞ i kružnica d_2
- **izvodnice** - prave linije i

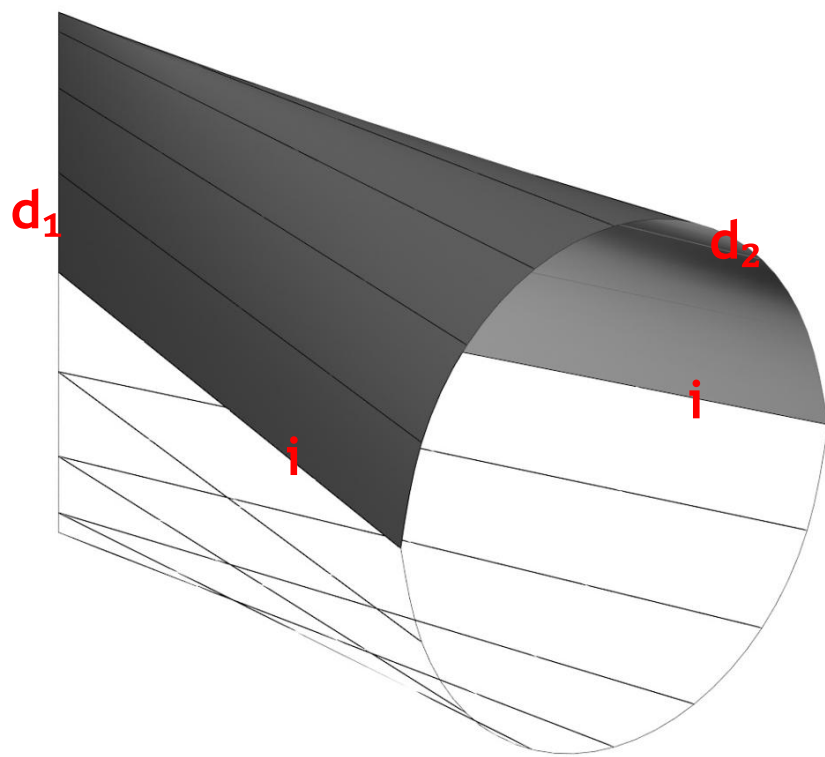

Sl.1

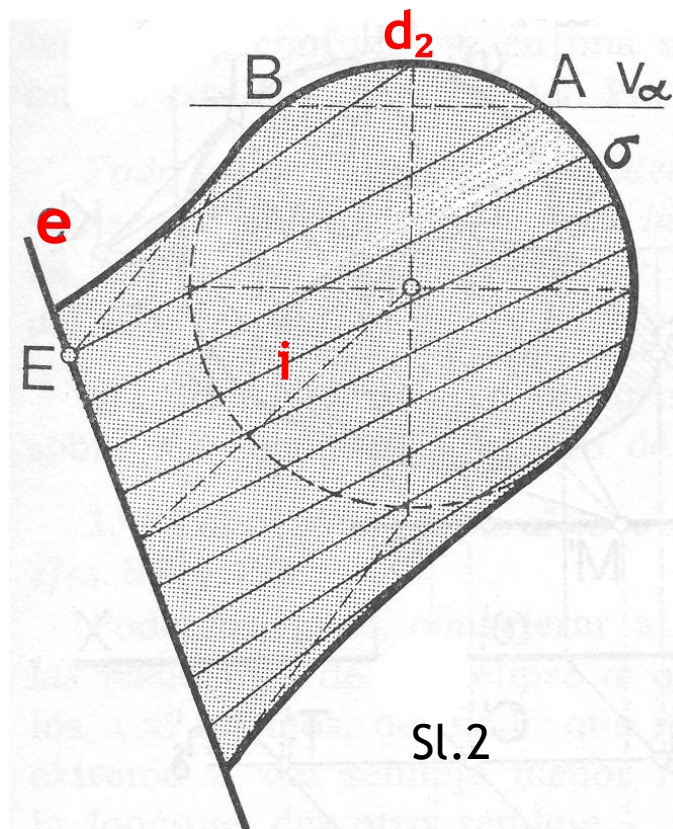

Sl.2

KONOIDI

aksonometrija

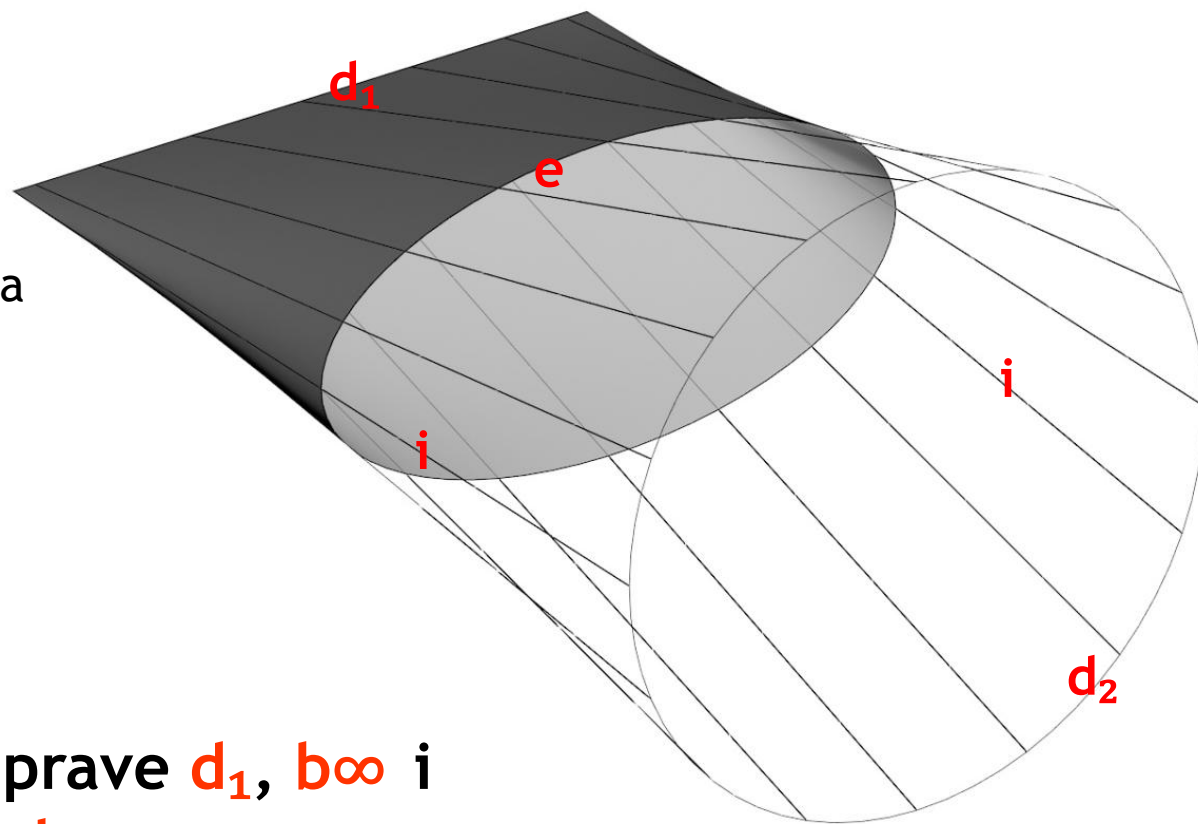

- **vodilje** - prave d_1 , b_∞ i kružnica d_2
- **izvodnice** - prave linije i

KONOIDI

- **vodilje** - prave e , $b\infty$ i prostorna kriva ω
- **izvodnice** - prave linije i

aksonometrija

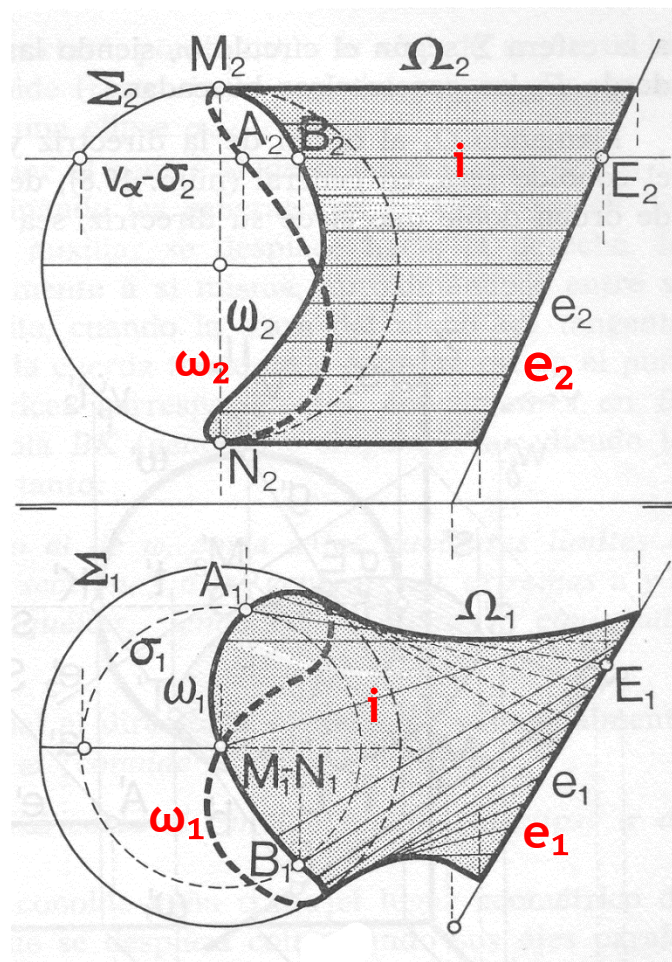
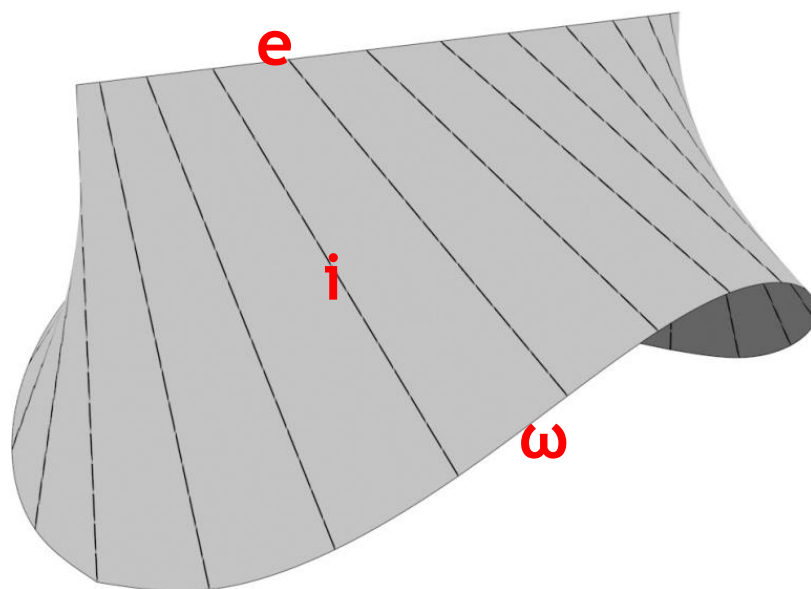

osnova i izgled

PRIMENA KONOIDA U ARHITEKTURI



KONOIDI

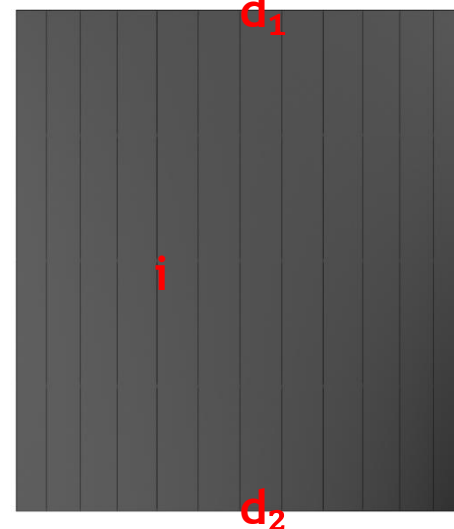
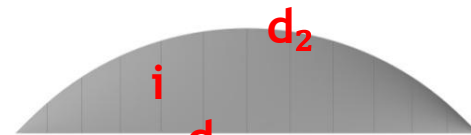
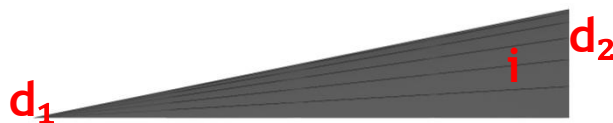

- **vodilje** - prave d_1 , $b\infty$ i kružnica d_2
- **izvodnice** - prave linije i

aksonometrija

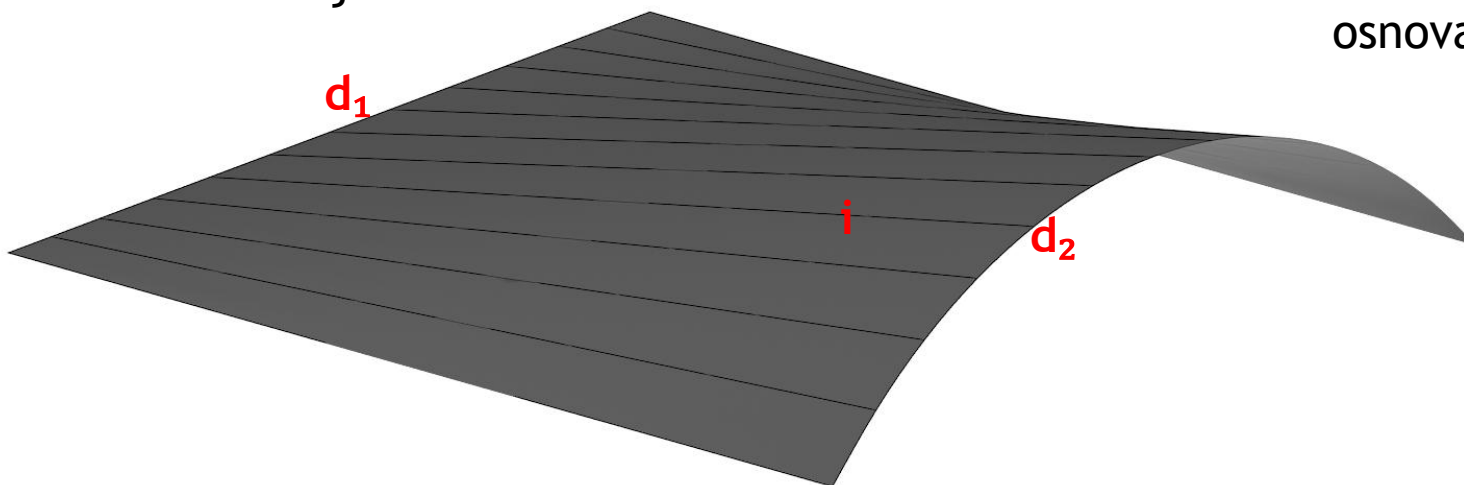

osnova i izgledi

KONOIDI

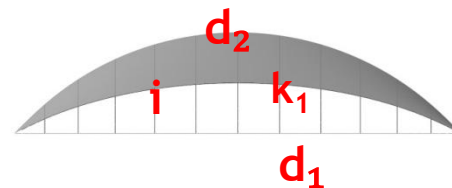
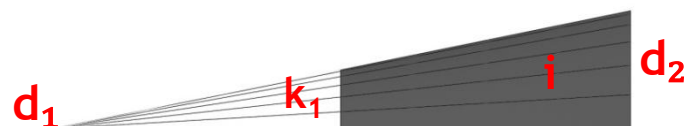

- **vodilje** - prave d_1 , $b\infty$ i kružnica d_2
- **izvodnice** - prave linije i

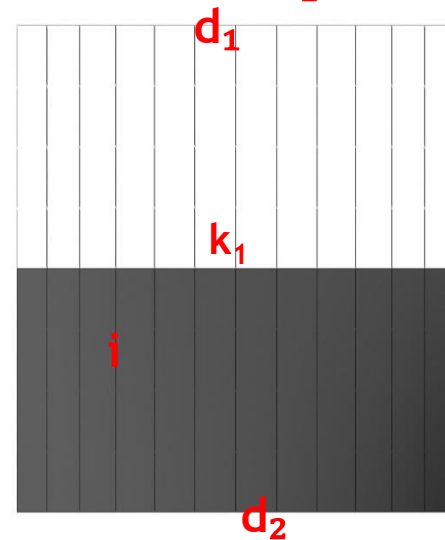

aksonometrija

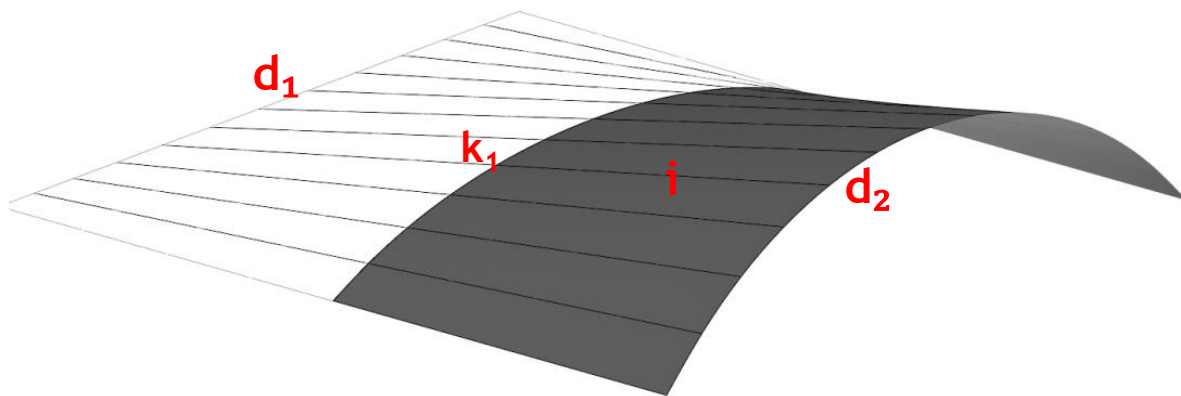

osnova i izgledi

Primena konoida u arhitekturi

Konoidi kao ljuske za pokrivanje objekata

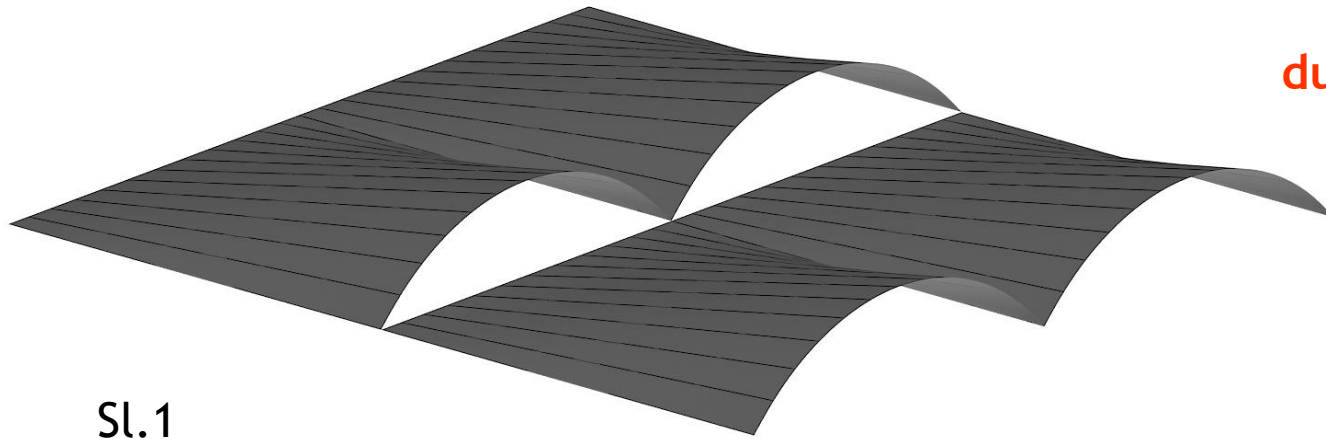

duge konoidne ljuske

Sl.1

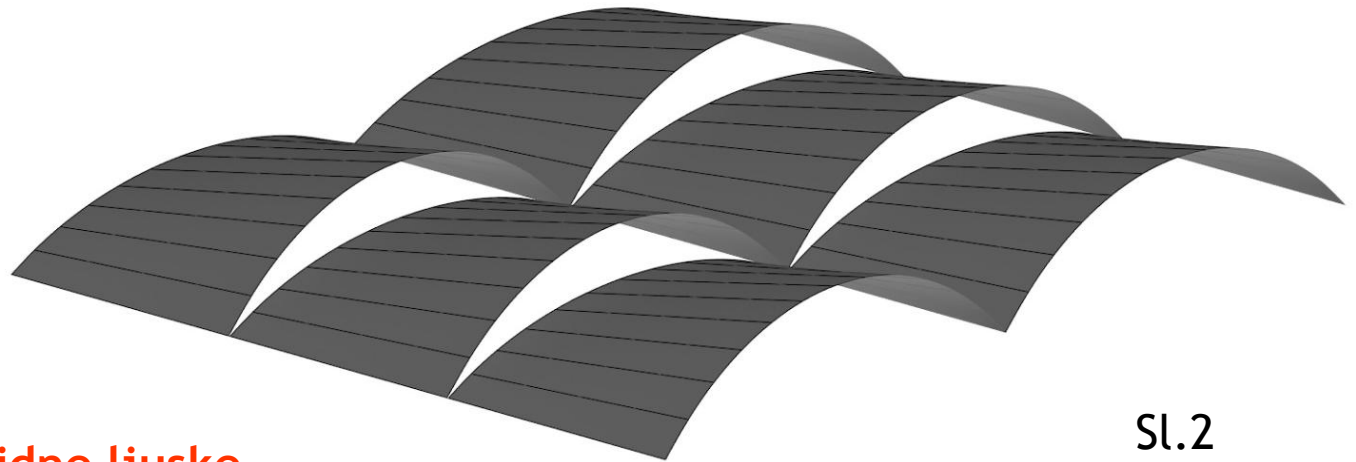

kratke konoidne ljuske

Sl.2

Primena konoida u arhitekturi



Oxford železnička stanica, Mančester , UK, arch. W. R. Headley and M. Glendinning, 1960.g

Primena konoida u arhitekturi



Crkva Atlantida, Atlantida ,Urugvaj, arh. Eladio Dieste, 1952.g

Primena konoida u arhitekturi

Kratke konoidne ljuske

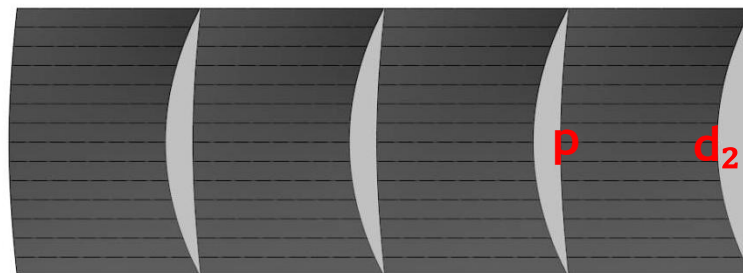
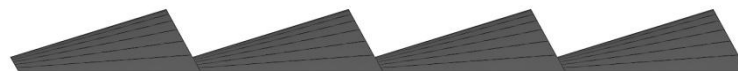

aksonometrija

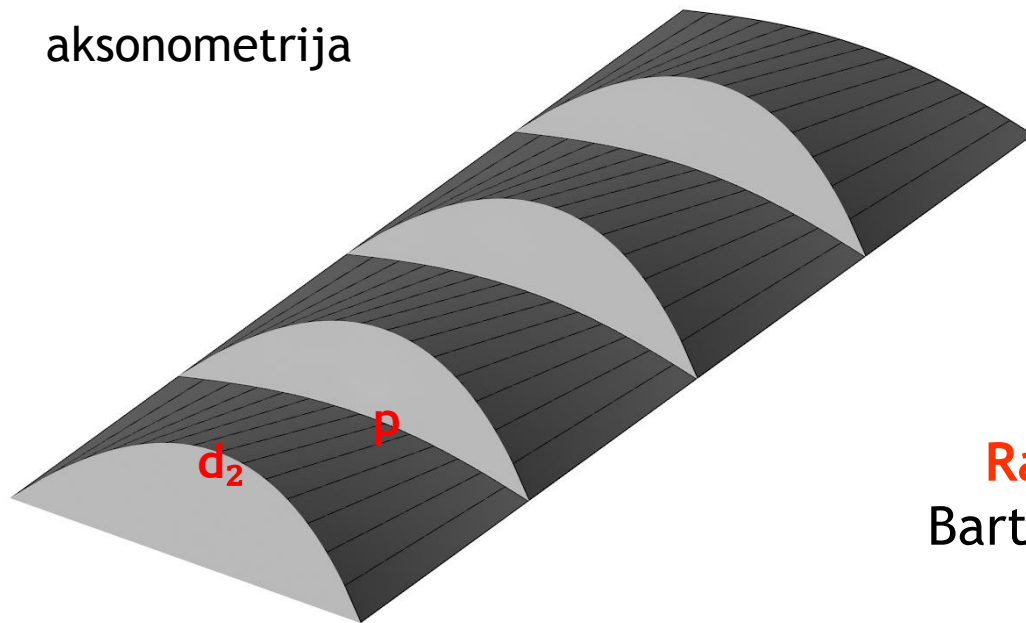

osnova i izgled

Raul Fernandez fabrika, San Bartolo, Meksiko, arh. F. Candela, 1950.g

Primena konoida u arhitekturi

Konoidne ljuske kao nadstrešnice



- **vodilje** - prave d_1 , b^∞
i kružnica d_2
- **izvodnice** - prave linije i



osnova i izgledi

aksonometrija

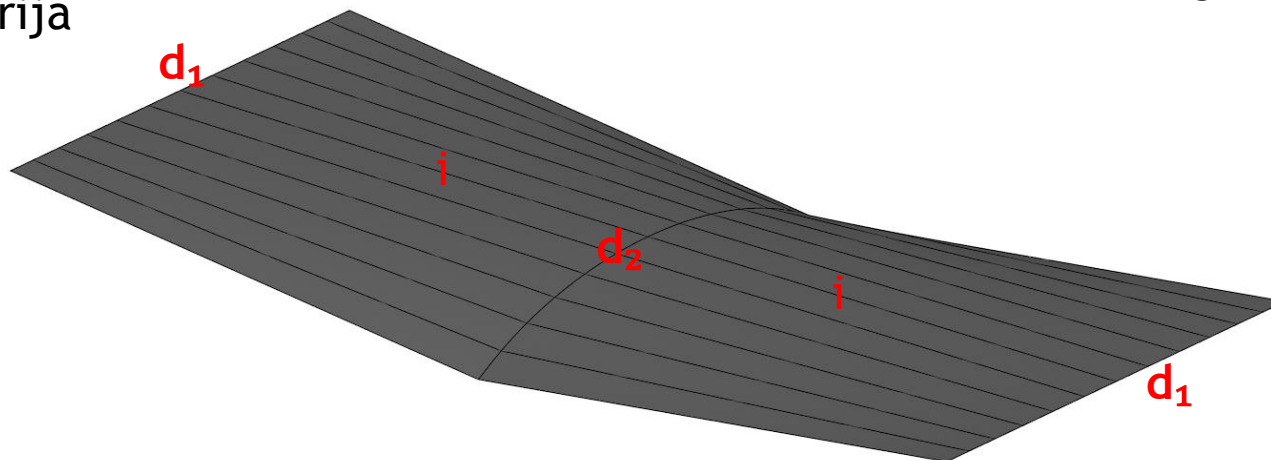

Primena konoida u arhitekturi

Konoidne ljske kao nadstrešnice

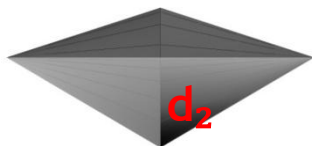

- **vodilje** - prave d_1 , b^∞
i kružnica d_2
- **izvodnice** - prave linije i

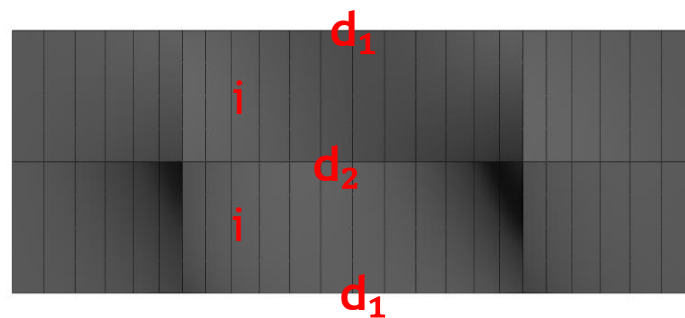
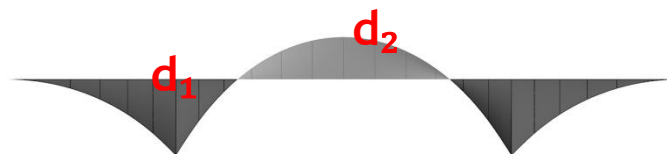

aksonometrija

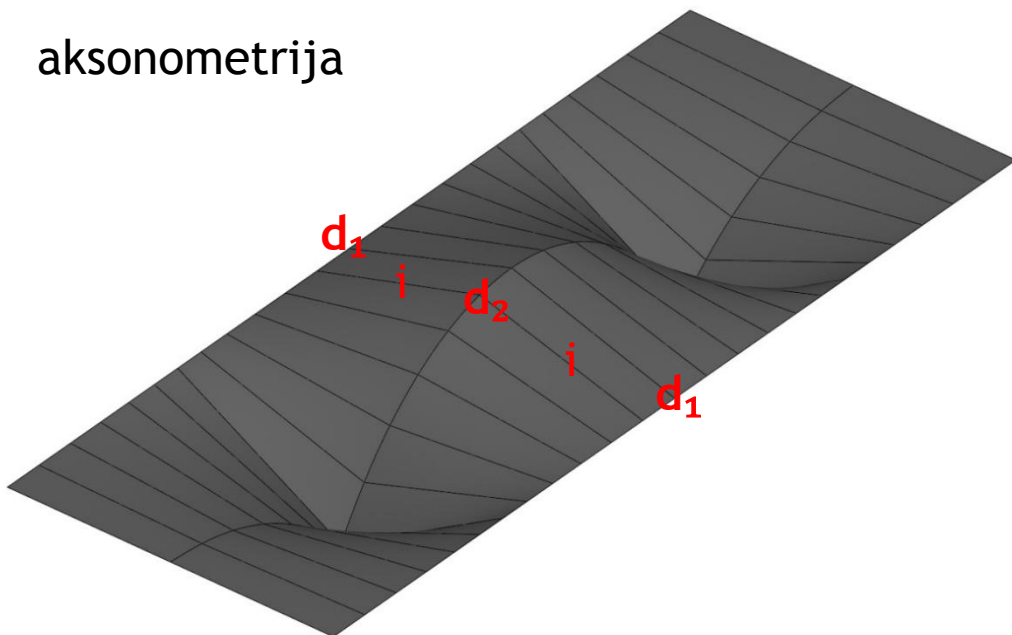

osnova i izgledi

Primena konoida u arhitekturi

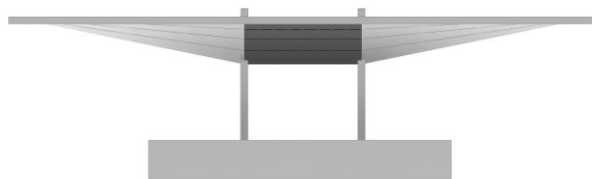

aksonometrija

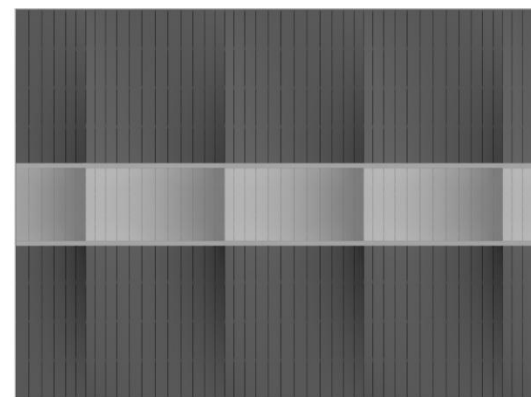
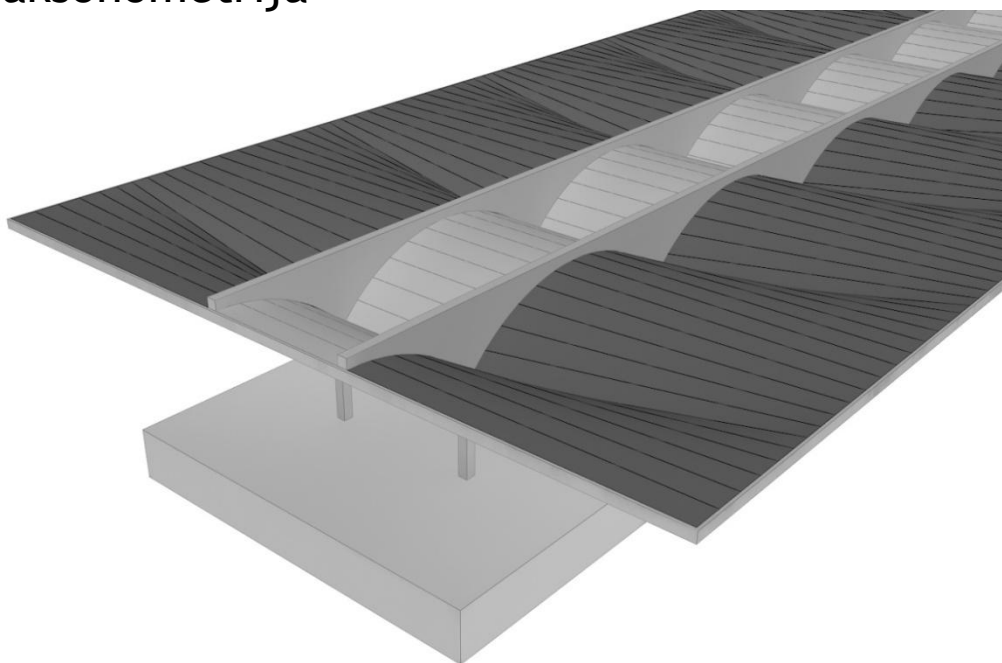

osnova i izgledi

Industrijski objekat Mlekara, Meksiko Siti, Meksiko, arh. C. Recamier, F. Candela, 1952.g

Primena konoida u arhitekturi

Konoidne ljuske kao nadstrešnice



- **vodilje** - prave d_1 , b^∞
i kružnica d_2
- **izvodnice** - prave linije i

aksonometrija

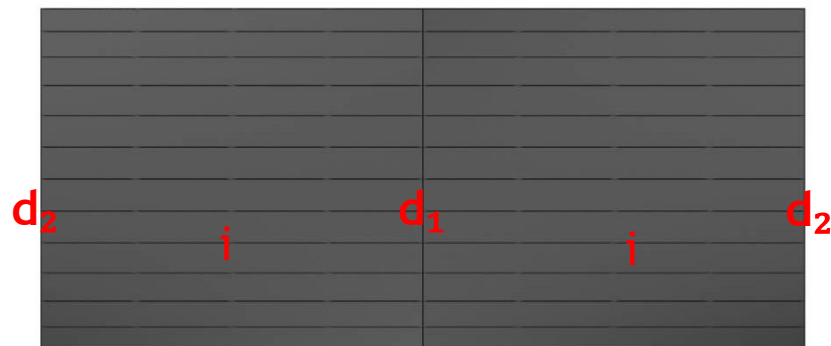

osnova i izgledi

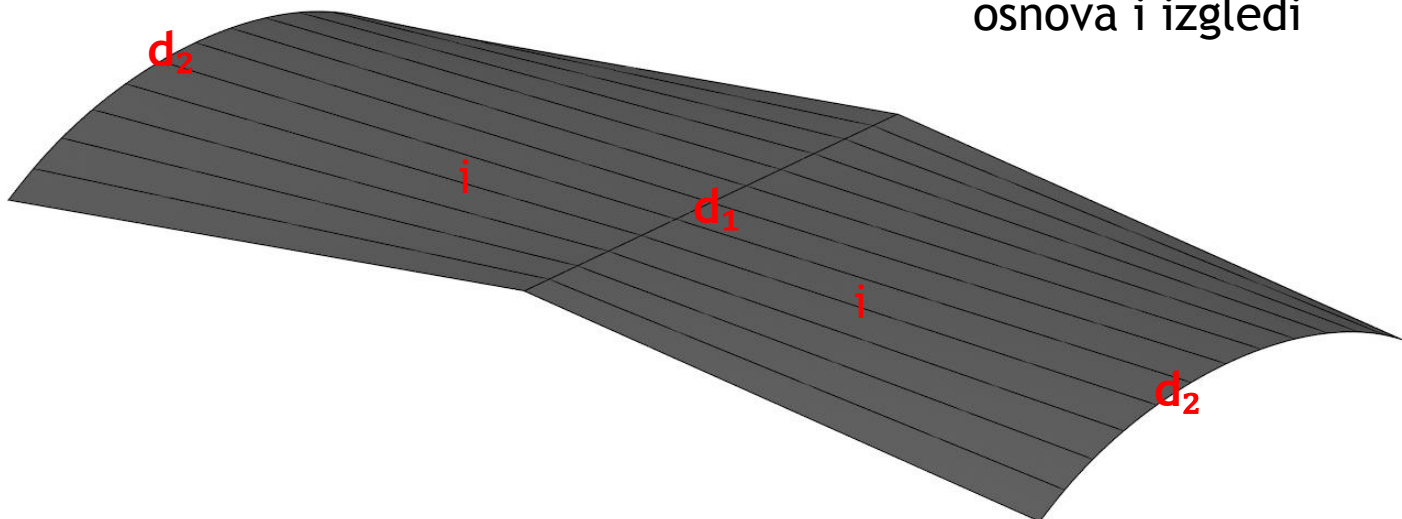

Primena konoida u arhitekturi



Škola svete porodice, Barselona, Katalonia, Španija, arh. Antoni Gaudi, 1926.g

Primena konoida u arhitekturi

Konoidne ljske kao nadstrešnice

- **vodilje** - prave d_1 , b^∞ i kružnica d_2
- **izvodnice** - prave linije i

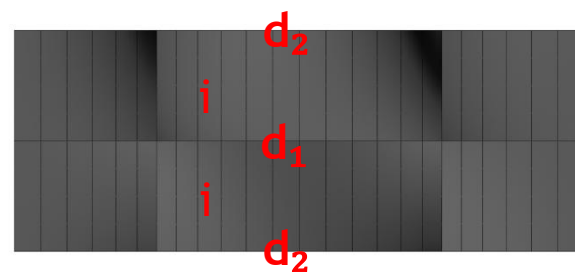
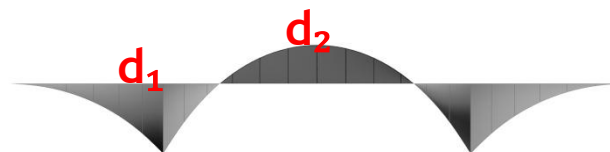
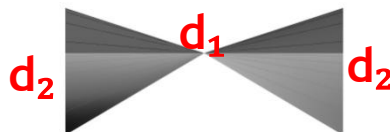

aksonometrija

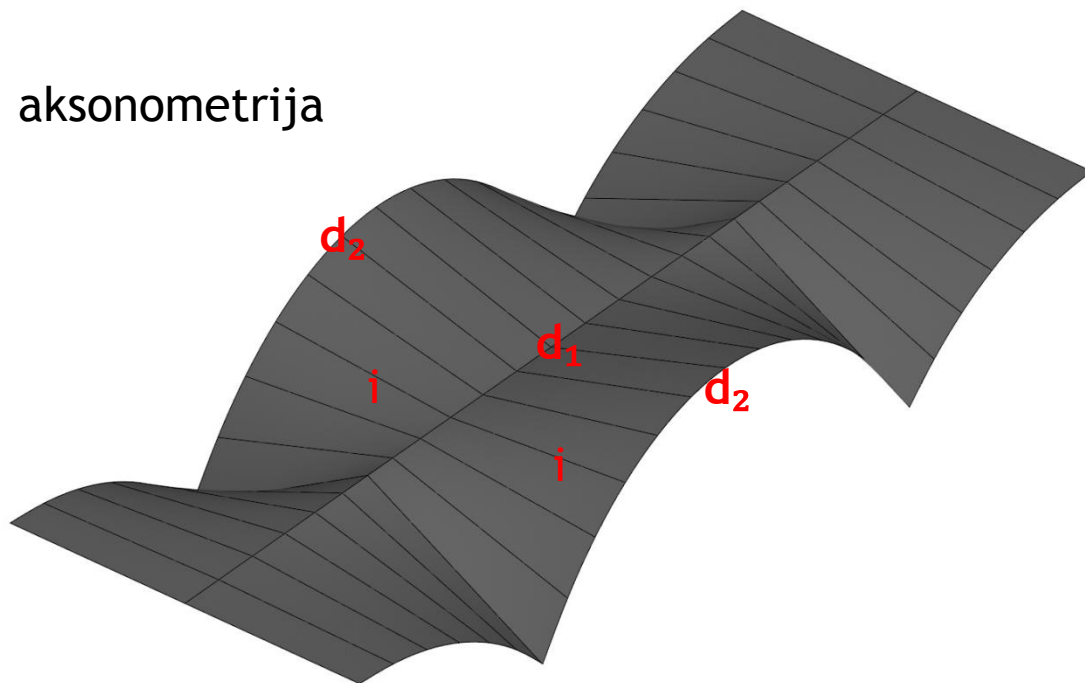

osnova i izgledi

Primena konoida u arhitekturi



Milvoki muzej umetnosti, Milvoki, Jezero Mičigen, SAD, arh. S. Calatrava, 2001.g

Primena konoida u arhitekturi

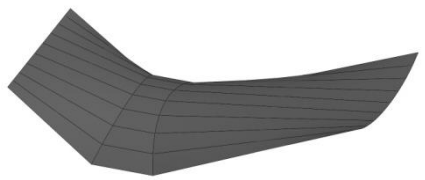

Nadstrešnica za Unesko, Pariz, Francuska, arh. Marcel Breuer, Pier Luigi Nervi i Bernard Zehruss, 1953.g

Primena konoida u arhitekturi



Lebdeći hram, Tokio, Japan, arh. Ishibashi, Tokugawa i Associates, 2010.g

KONOIDI

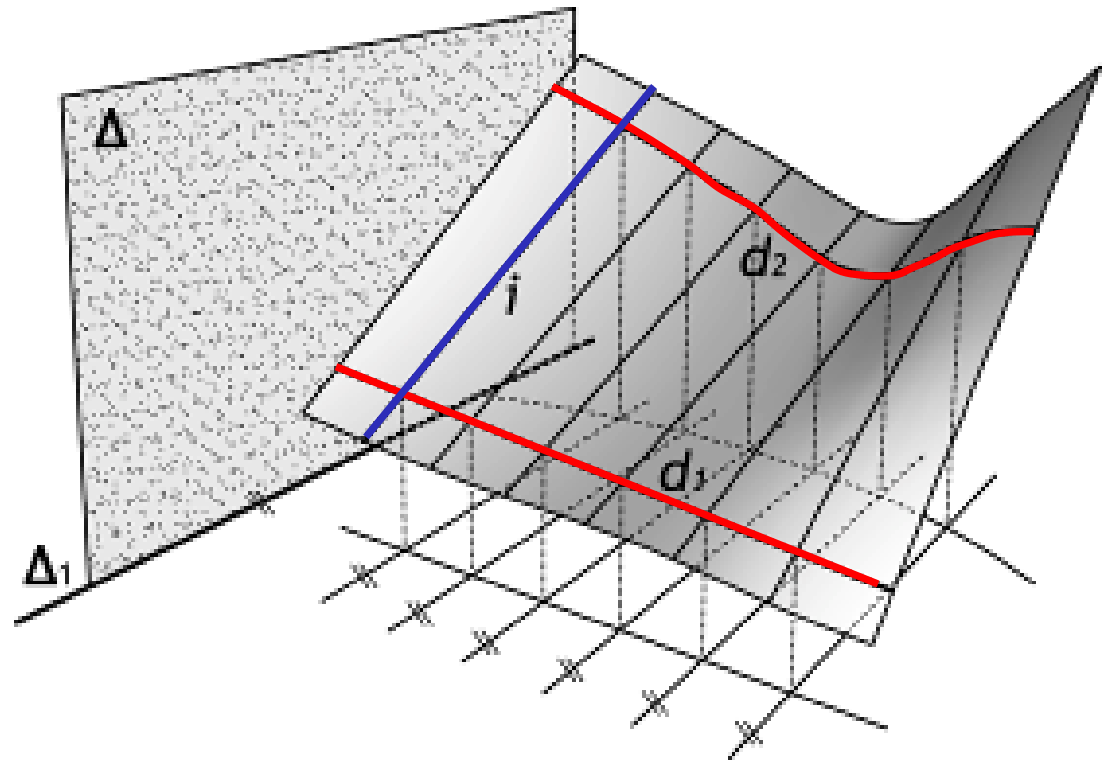

- **vodilje** - jedna prava u konačnosti d_1 , jedna beskonačno daleka prava b_∞ i ravna ili prostorna kriva d_2
- **izvodnice** - prave linije i paralelne direktrisnoj ravni Δ



TETROIDI

TETROIDI

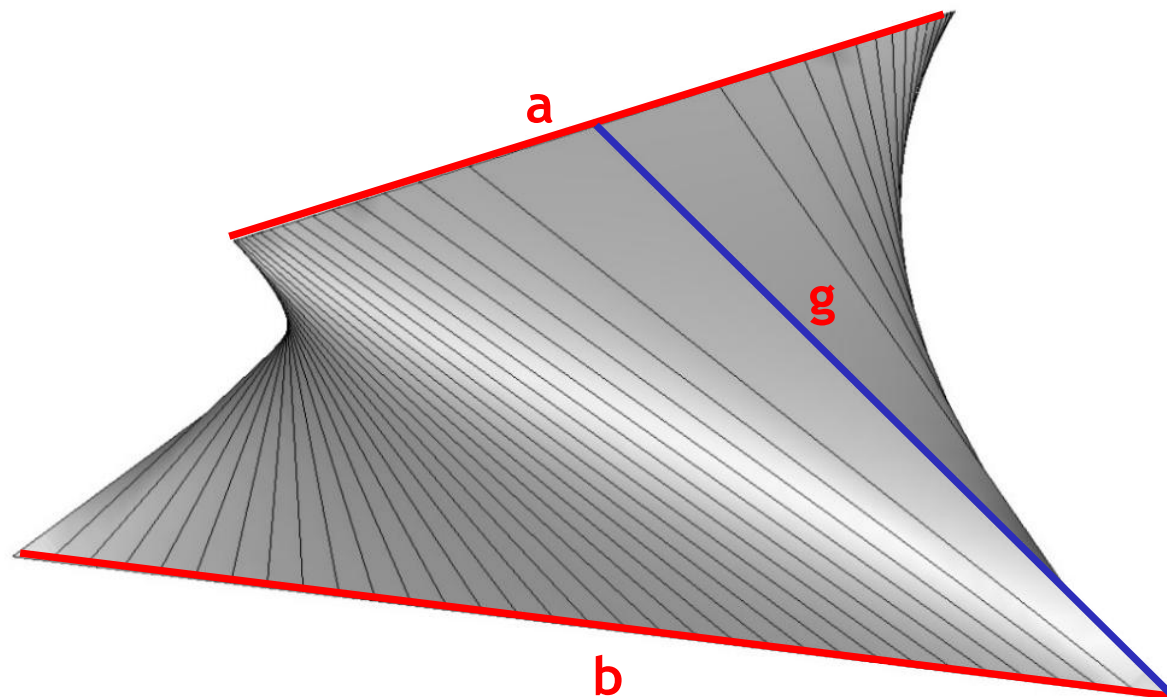

Sl. 1

- **vodilje** - dve prave u konačnosti **a, b** i beskonačno daleka kriva k_{∞}
- **izvodnice** - prave linije **g**

TETROIDI

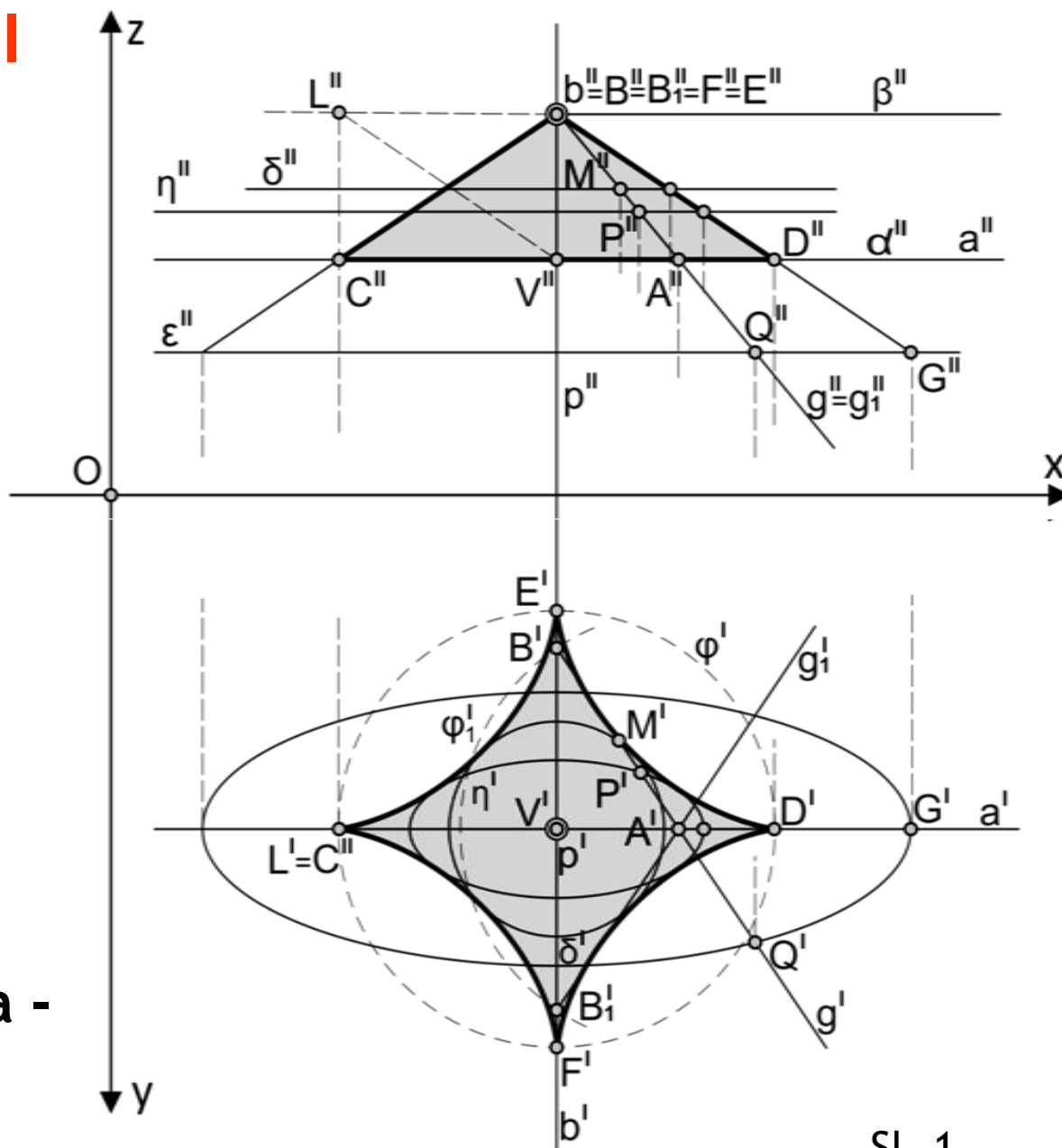

- prva projekcija - ravna kriva
astroida
- druga projekcija - **trougao**

TETROIDI

Ravni preseki

- elipsa - duža osa paralelna pravoj **a**

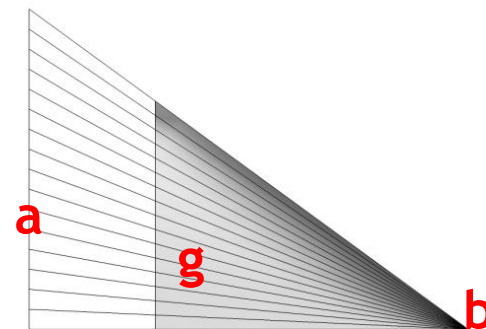
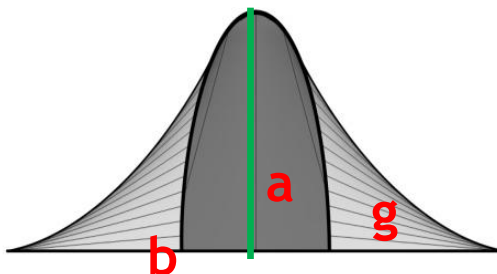

aksonometrija

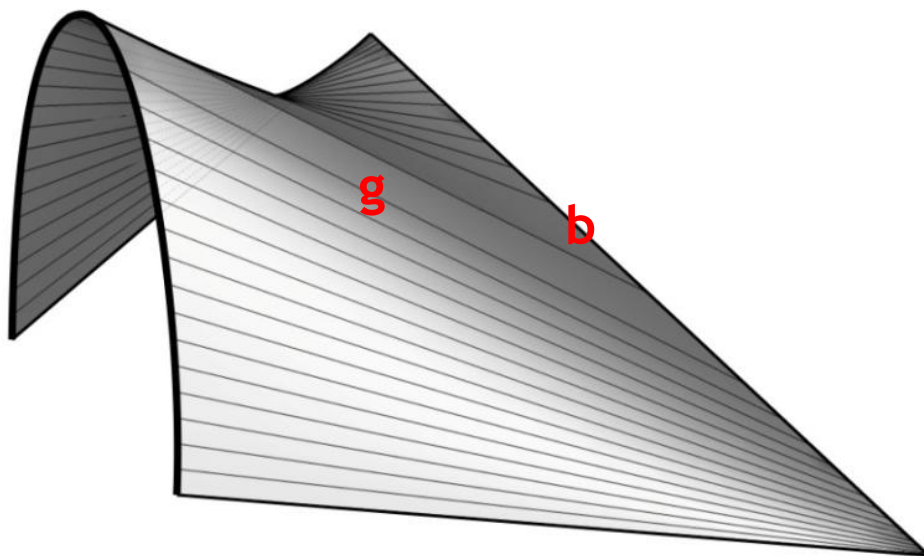

osnova trapez

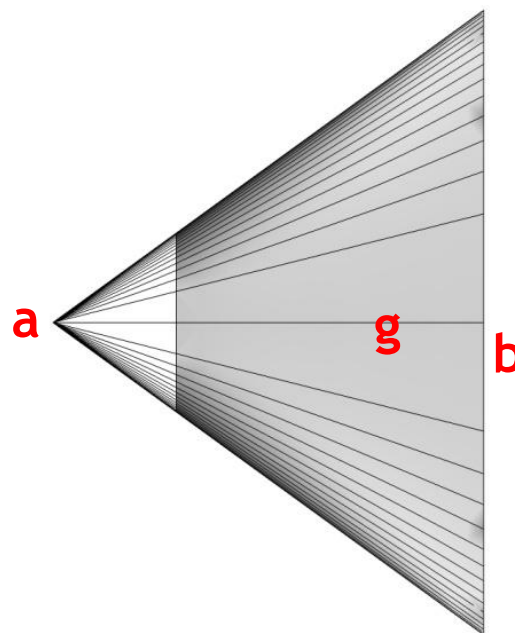

osnova i izgledi

TETROIDI

Ravni preseki

- elipsa e_1 - l duža osa paralelna pravoj a
- elipsa e_2 - duža osa paralelna pravoj b

aksonometrija

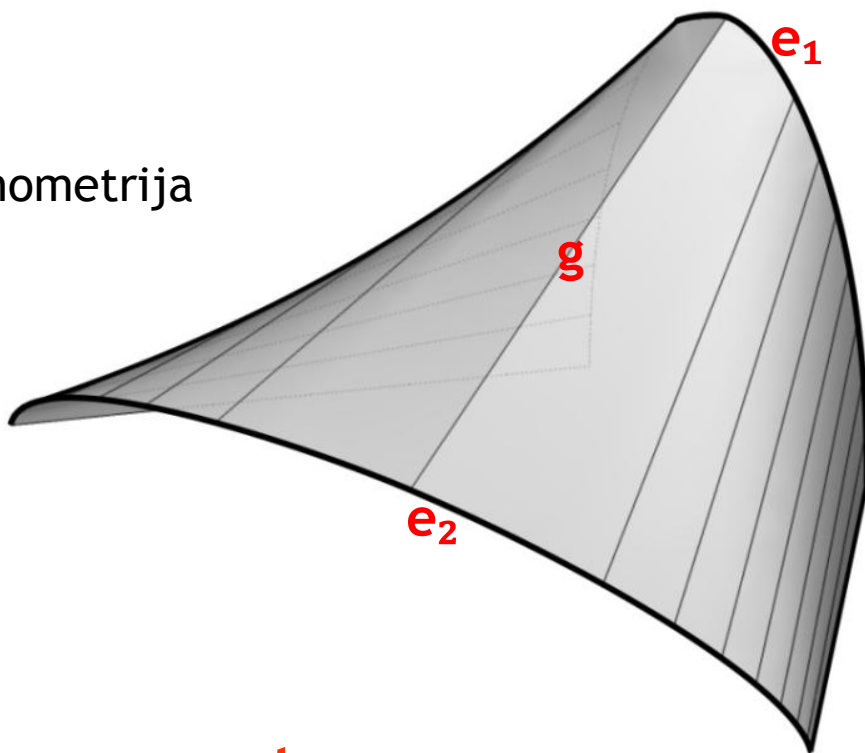

osnova trapez

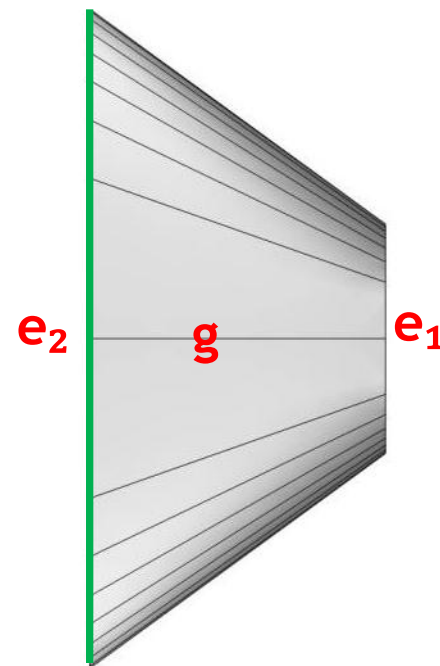

osnova i izgled

PRIMENA TETROIDA U ARHITEKTURI

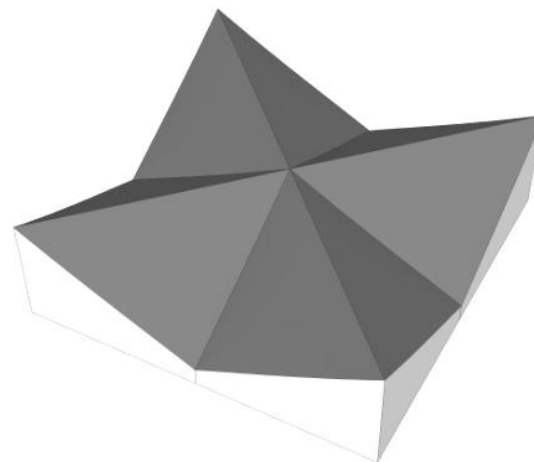
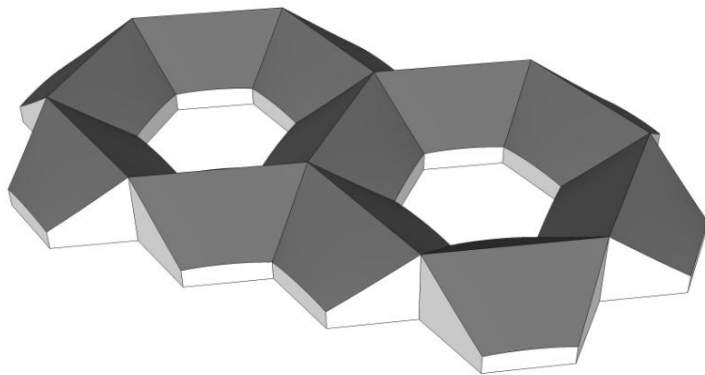
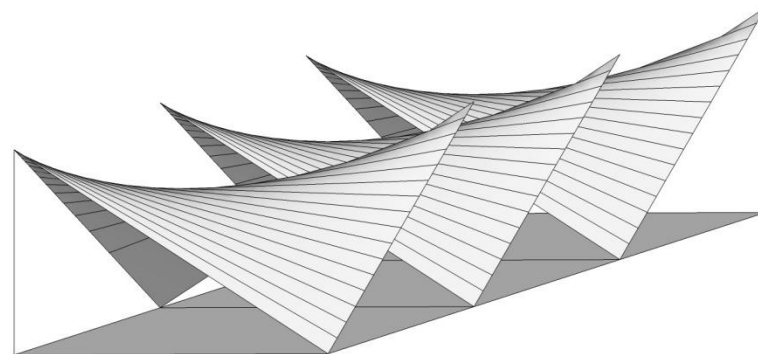
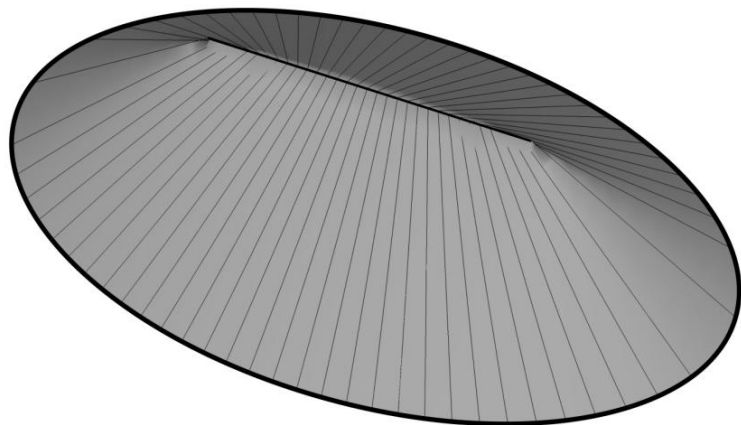

Primena tetroida u arhitekturi

Četvrtina tetroida

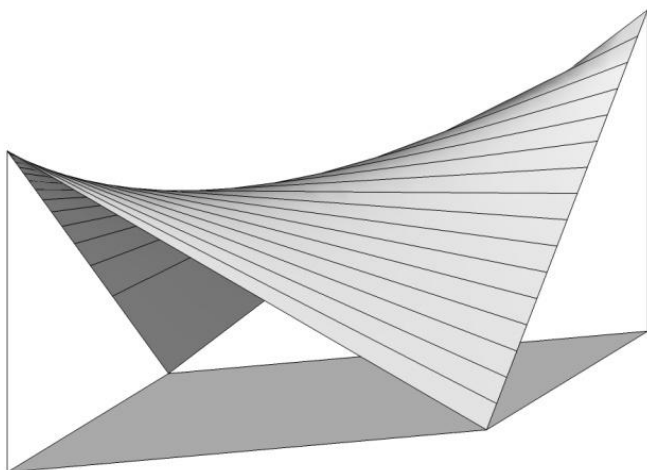
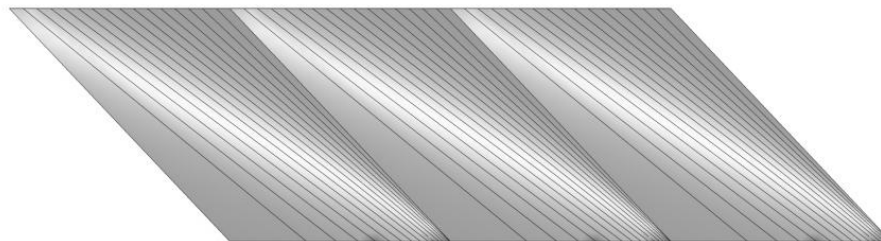
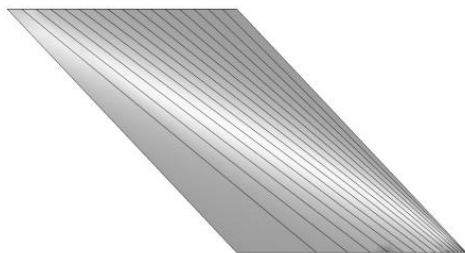

Sl.1

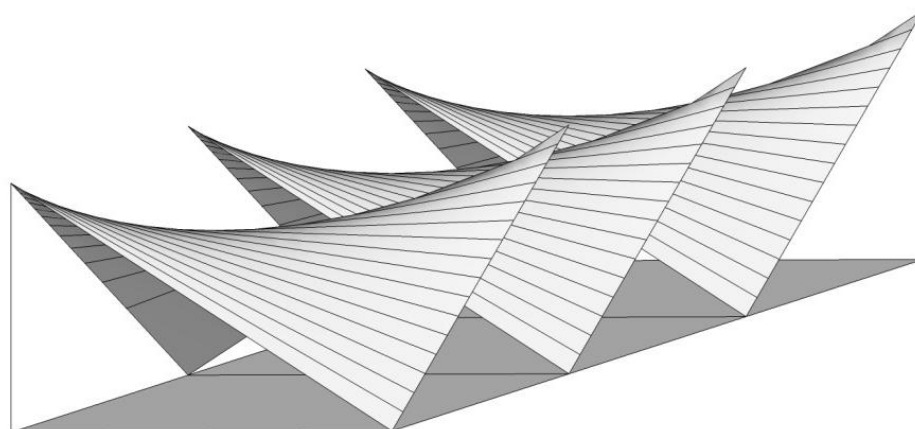

Sl.2

osnova paralelogram

Četvrtina tetroida

aksonometrija

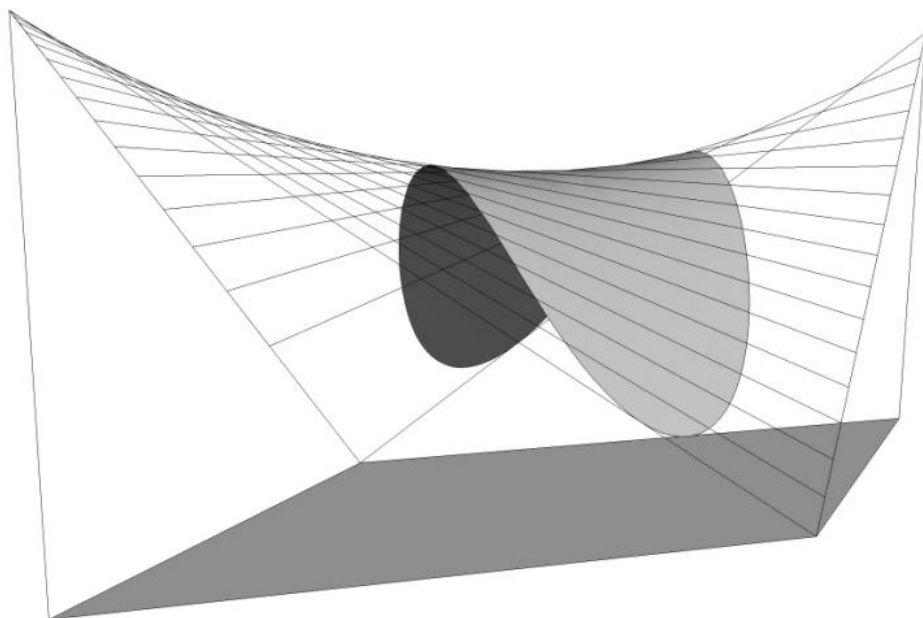

kružna osnova

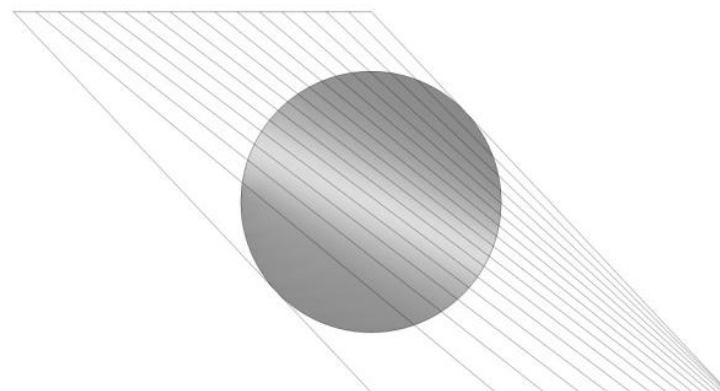
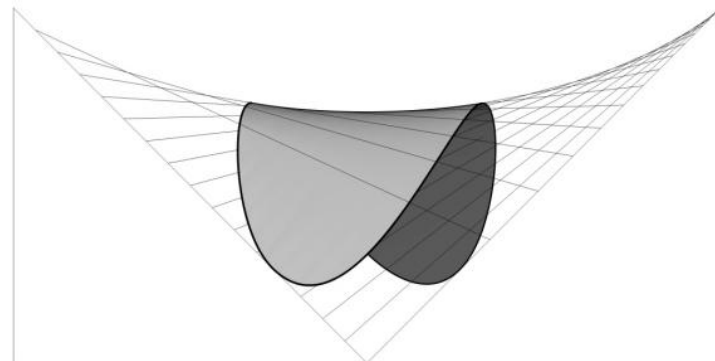

osnova i izgled

Polovina tetroida

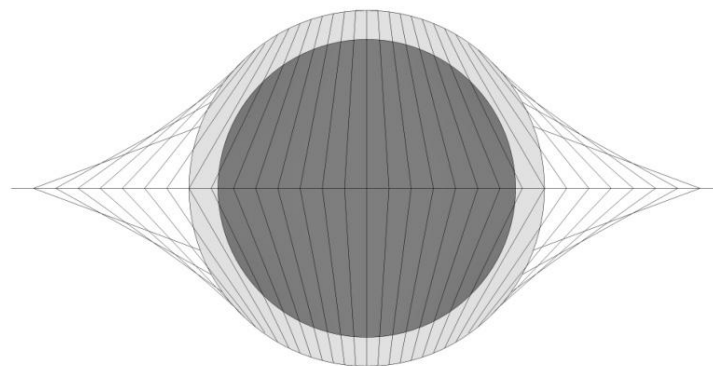
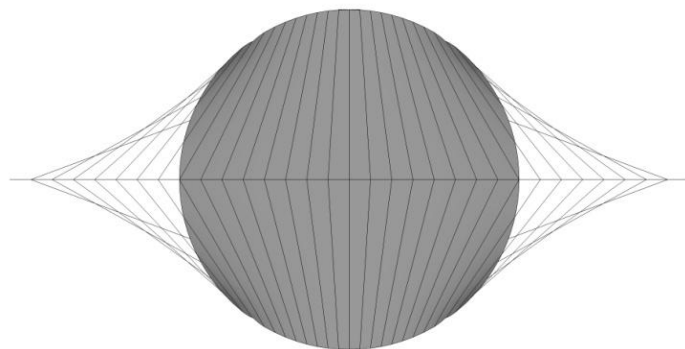
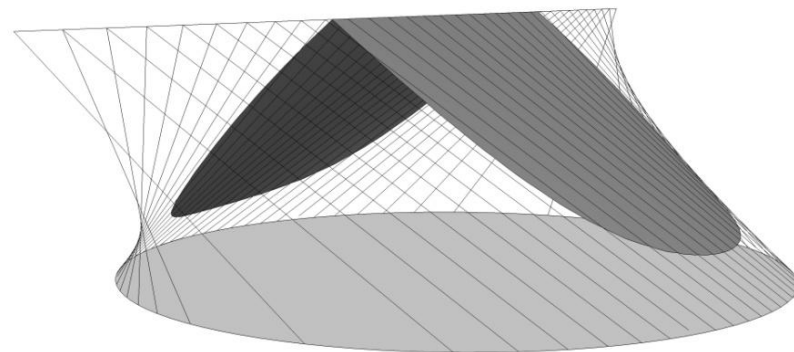
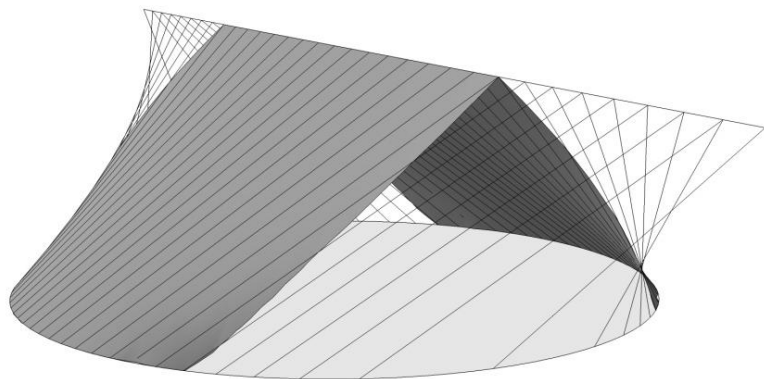

Sl.1

Sl.2

kružna osnova

Polovina tetroida

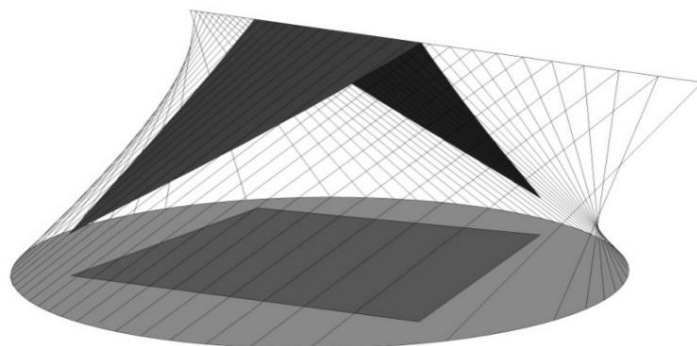

Sl.1

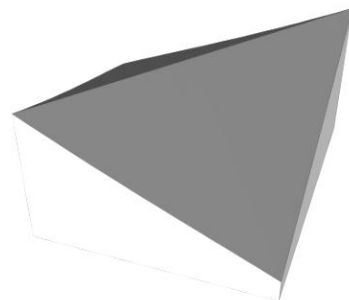

Sl.2

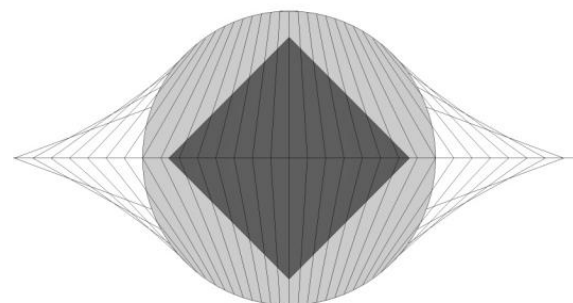

Sl.3

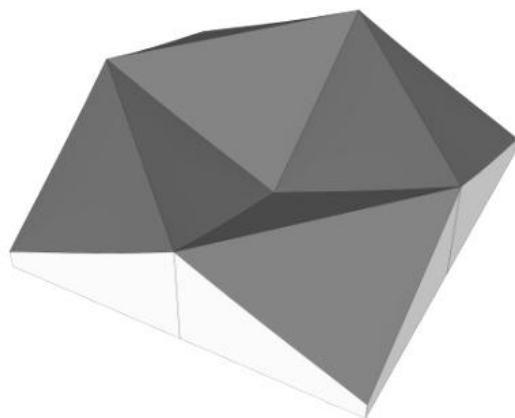

Sl.4

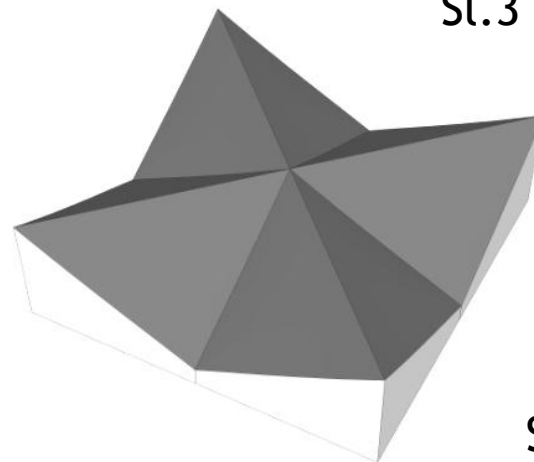

Sl.5

kvadratna osnova

Primena tetroida u arhitekturi

Prodori

Polovina tetroida

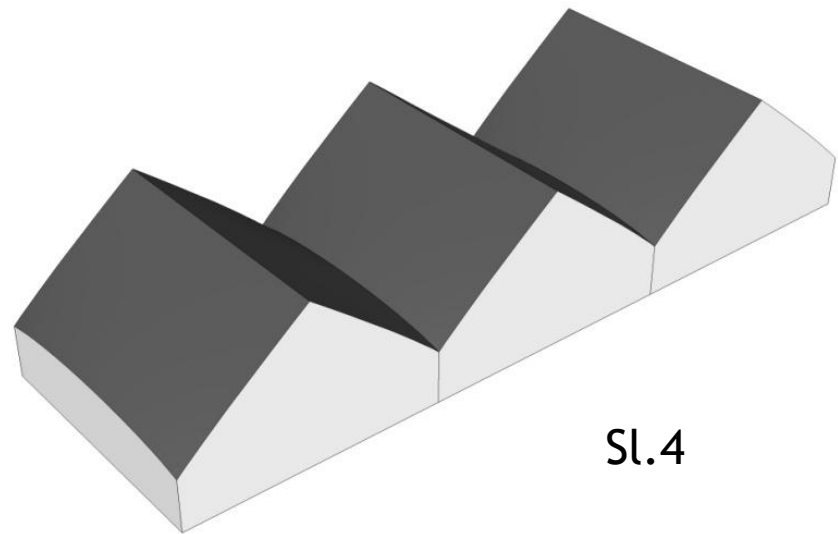
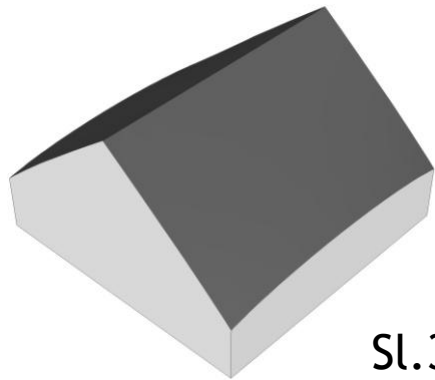
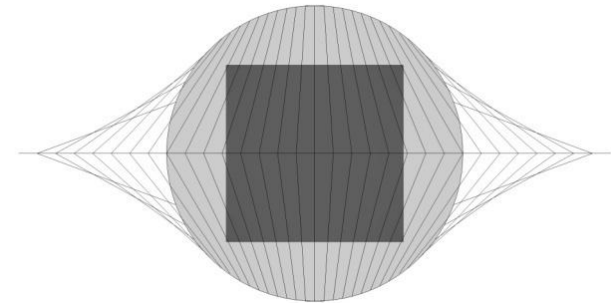
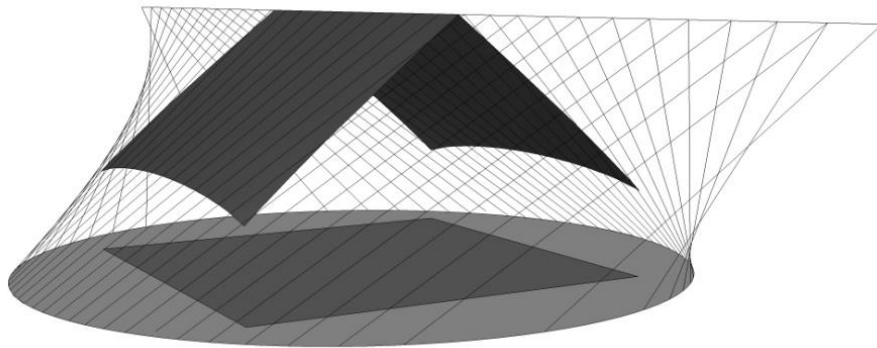

kvadratna osnova

Primena tetroida u arhitekturi

Prodori

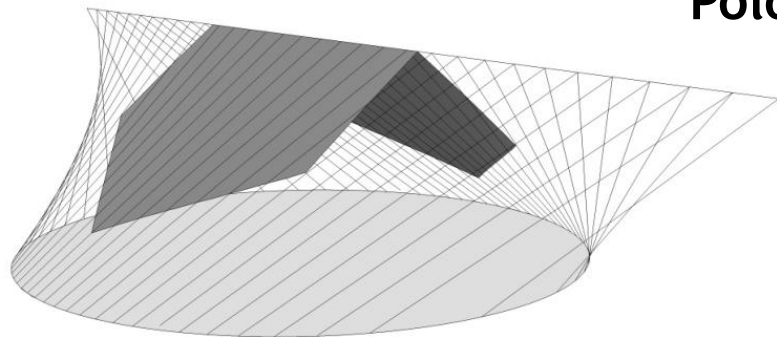

Sl.1

Polovina tetroida

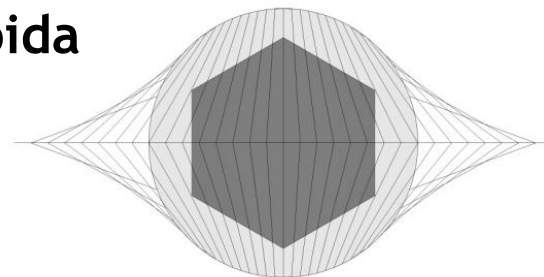

Sl.2

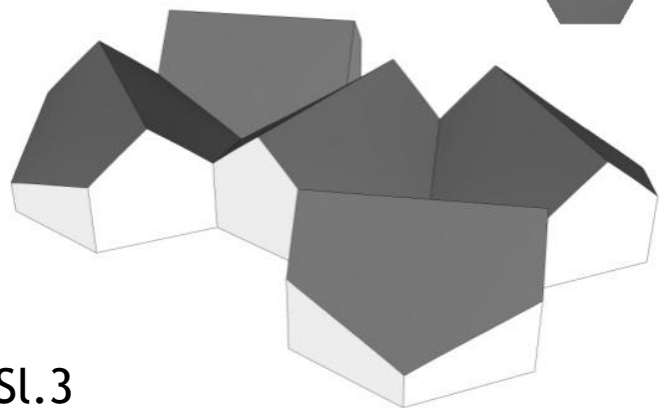
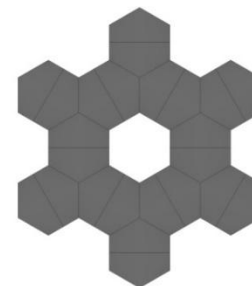
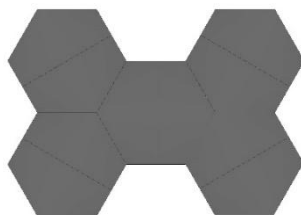

Sl.3

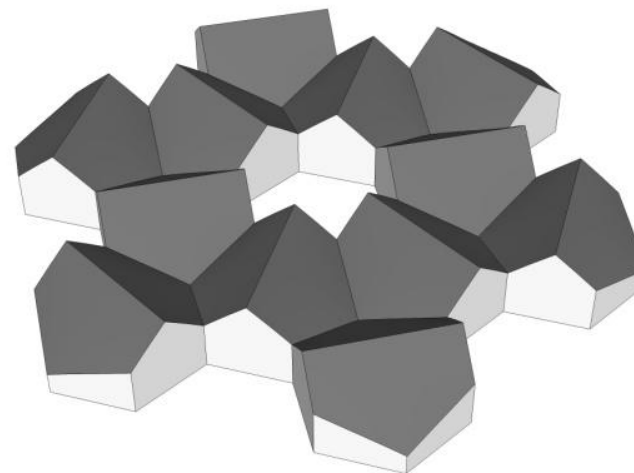

Sl.4

šestougaona osnova

Primena tetroida u arhitekturi

Prodori

Polovina tetroida

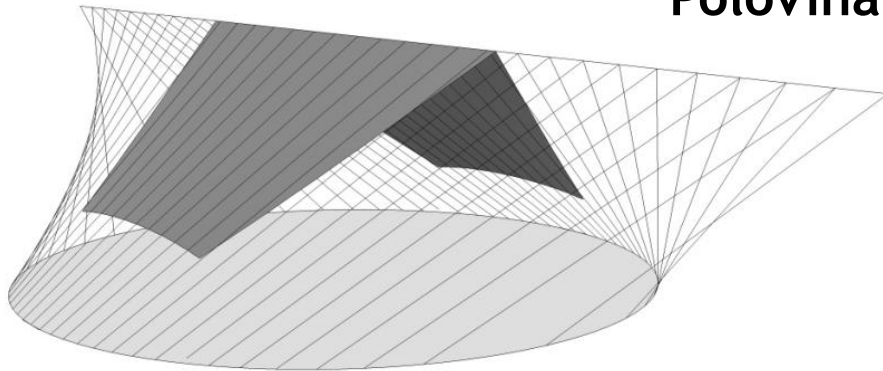

Sl.1

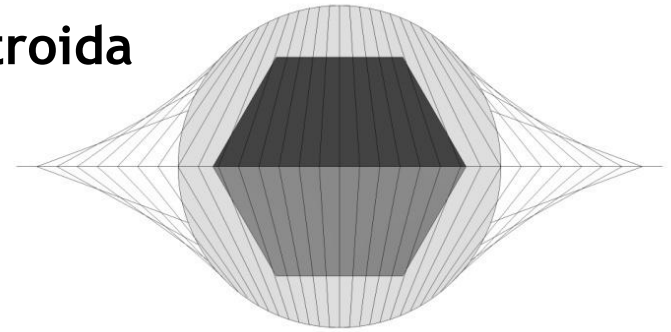

Sl.2

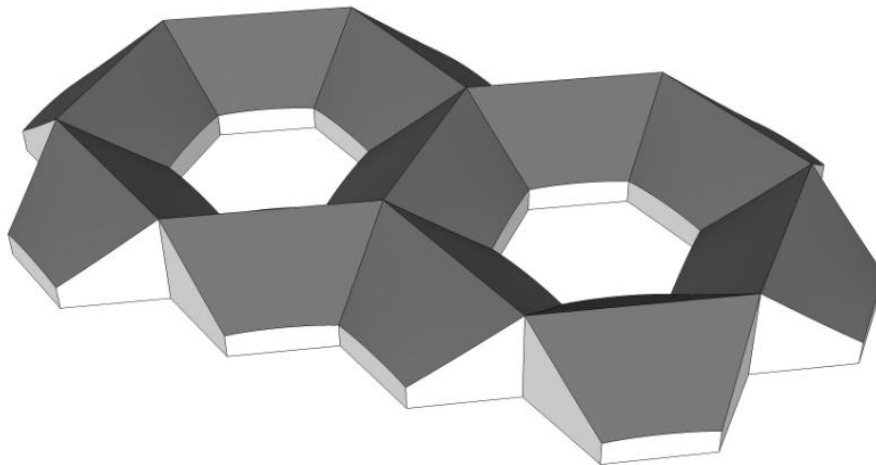

Sl.3

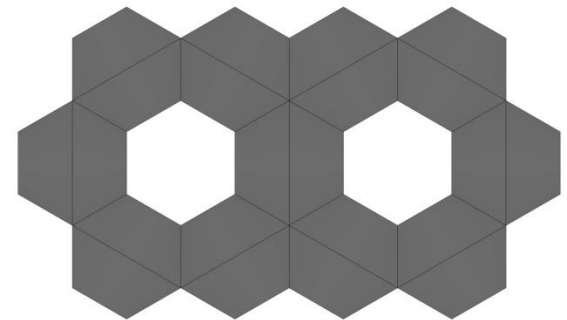

Sl.4

šestougaona osnova

TETROIDI

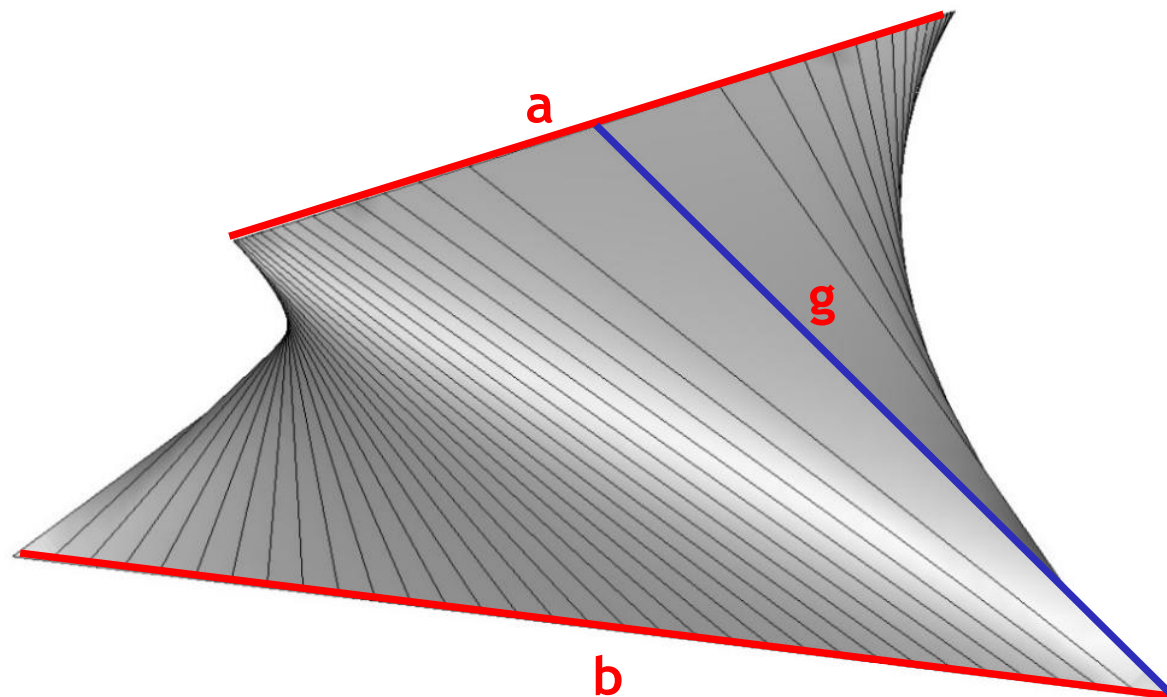

- **vodilje** - dve prave u konačnosti **a, b** i beskonačno daleka kriva **k_∞**
- **izvodnice** - prave linije **g**



Studentski grafički radovi

Primena cilindroida u arhitekturi



Srđan Sakan, grafički rad, student, generacija 2010/11

Primena cilindroida u arhitekturi

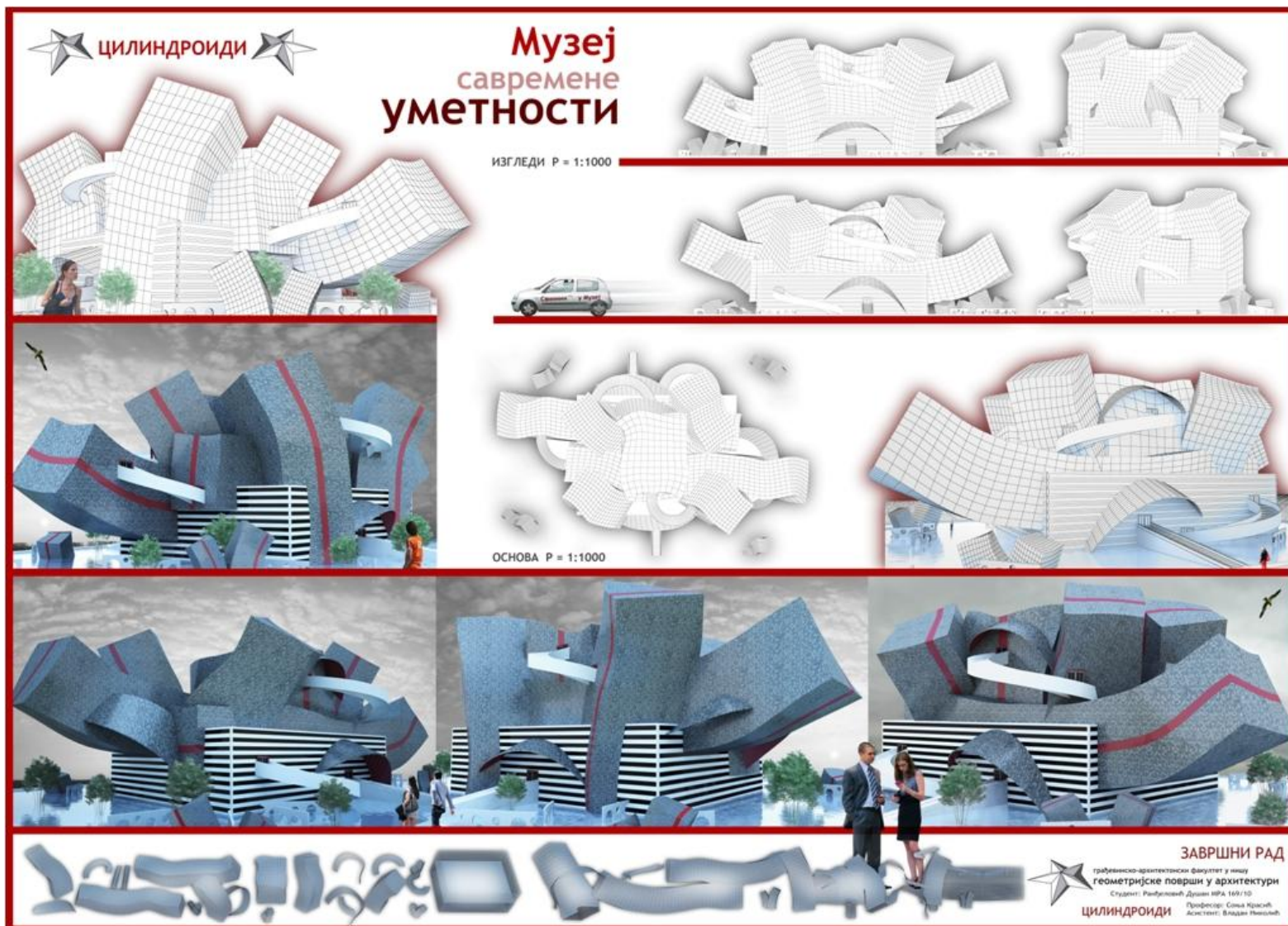

Dušan Randelović, grafički rad, student, generacija 2011/12

Primena cilindroida u arhitekturi

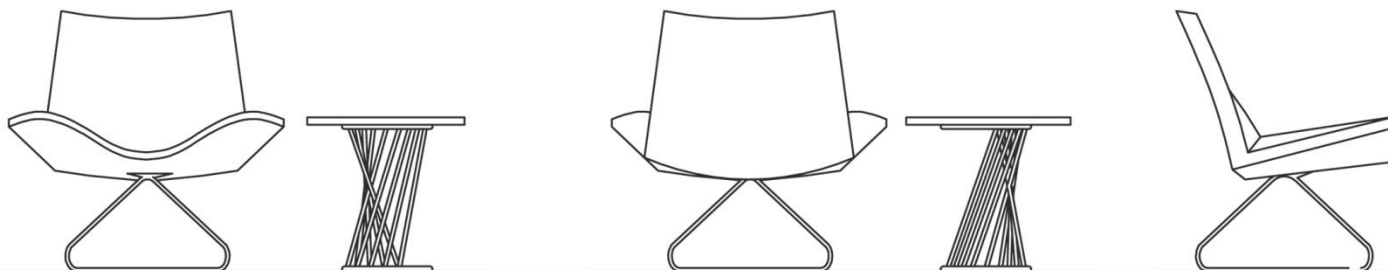

5

грађевинско-архитектонски факултет у нишу
геометријске површи у архитектури
Александра Цветковић мр 231/12

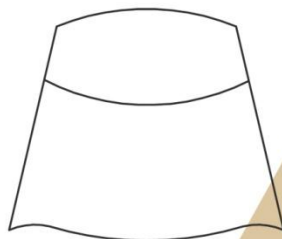

Aleksandra Cvetković, grafički rad, student, generacija 2012/13

Primena cilindroida u arhitekturi



5 цилиндроиди



грађевинско-архитектонски факултет у нишу
геометријске површи у архитектури
Душан Лилић МРА 234/12



Dušan Lilić, grafički rad, student, generacija 2012/13

Primena cilindroida u arhitekturi



ЦИЛИНДРОИДИ И КОНОИДИ
Институт за графичко инжењерство и архитектуру
Милан Брзаковић, март 2012

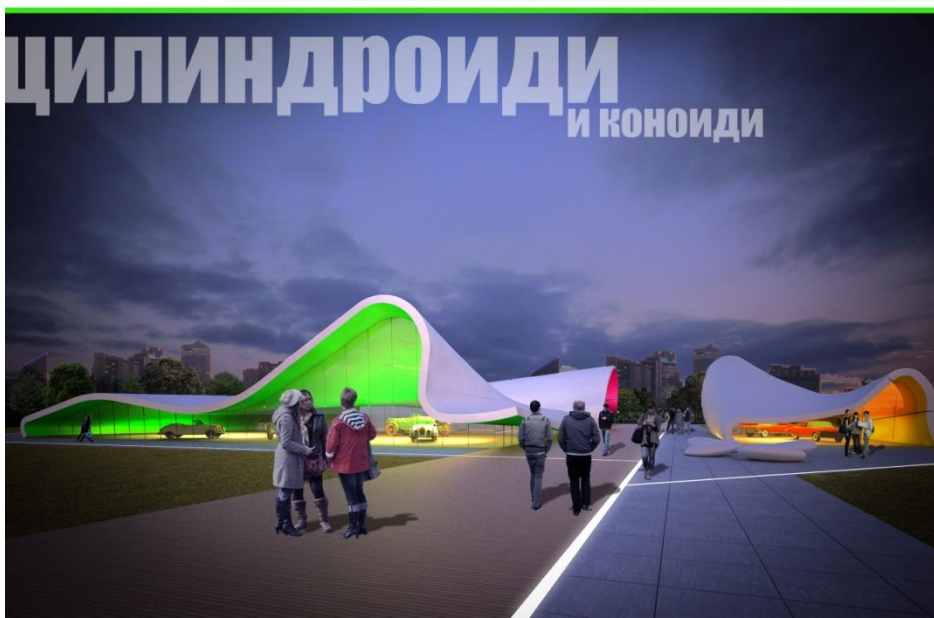
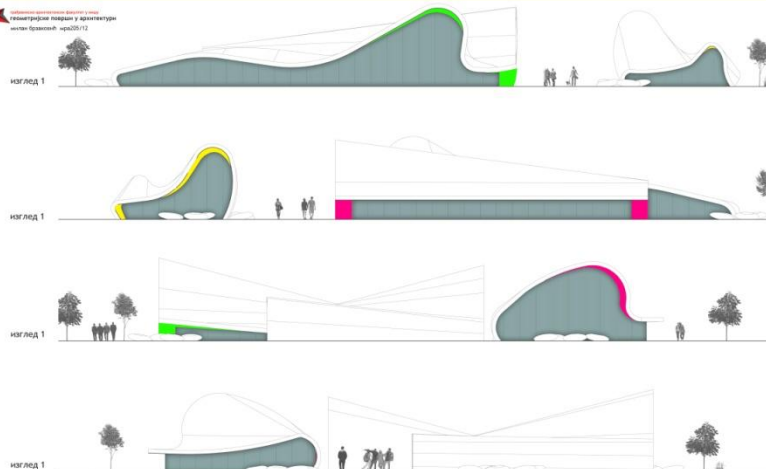

Milan Brzaković, grafički
rad, student, generacija
2012/13

Primena cilindroida u arhitekturi

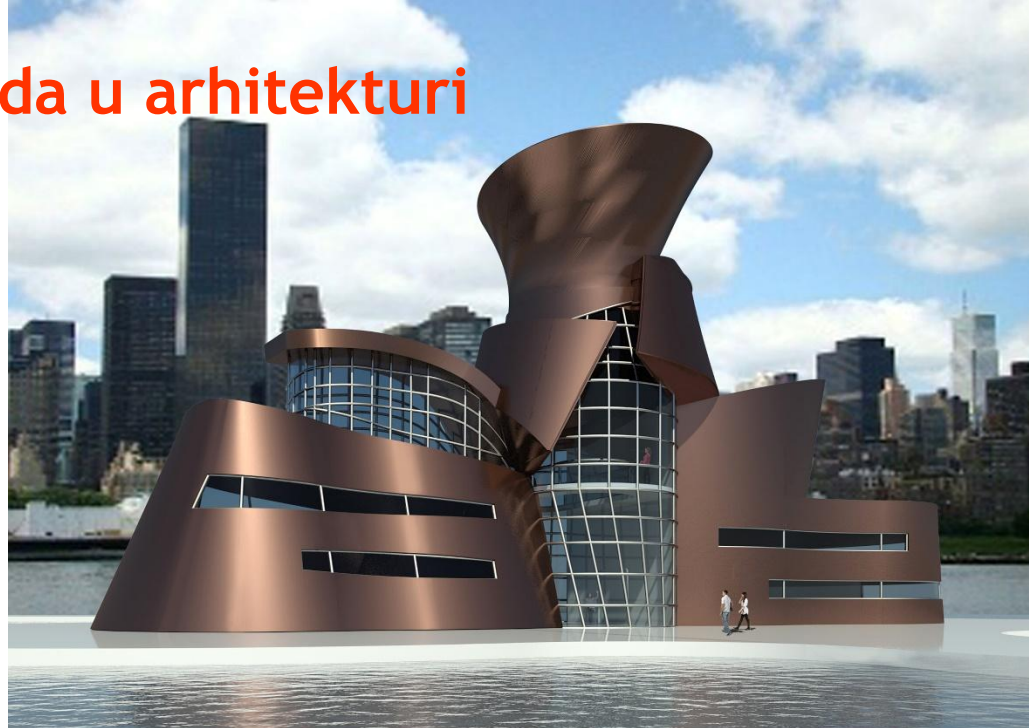

НЕРАЗВОЈНЕ ВИТОПЕРНЕ ПРАВИЗВОДНЕ ПОВРШИ ЈЕДНОСТРУКО-ИЗВОДНЕ ПРАВИЗВОДНЕ ПОВРШИ ЦИЛИНДРОИДИ



грађевинско-архитектонски факултет
геометријске површи у архитектури

професор: др Соња Кривош
ментор: Владимир Великовић
СТУДЕНТ: Милана Великовић МРБ 333/14

равна крива водиља β ;
изводница α - бесконачно далека права
параполна равни
равна крива водиља β ;

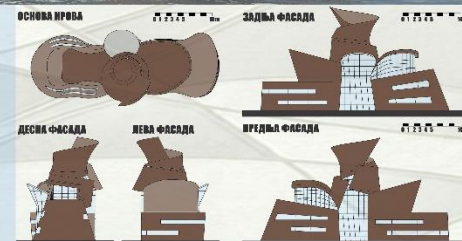
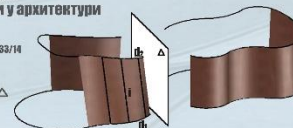

Milica Veljković, grafički rad,
student, generacija 2014/15



Primena konoida u arhitekturi

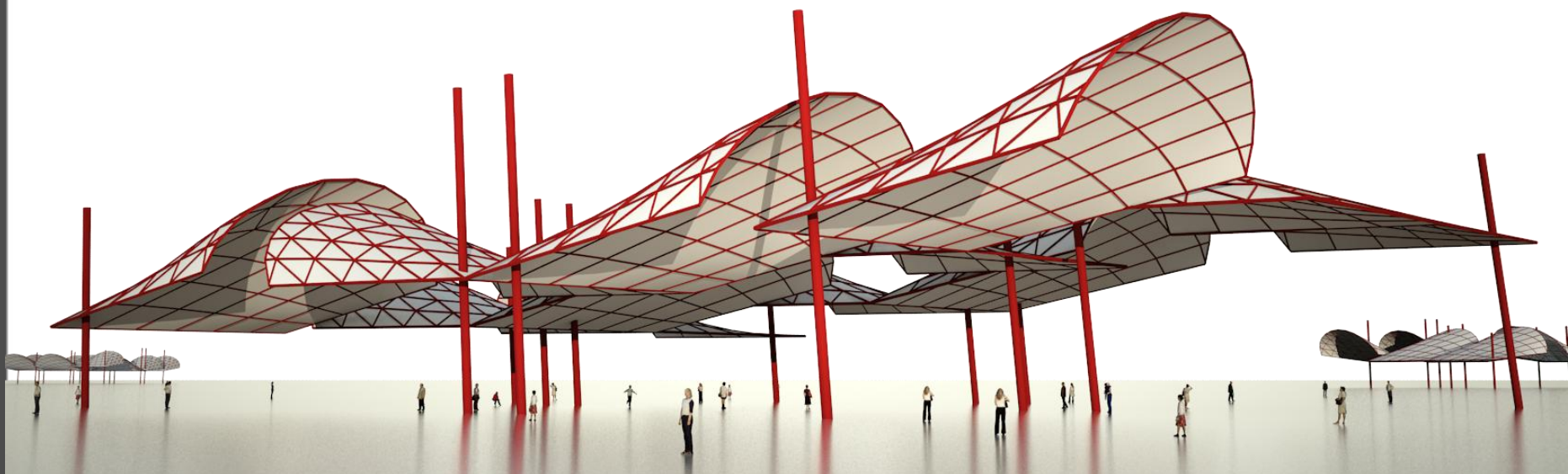

Tamara Manojlović, grafički rad, student, generacija 2009/10

Primena konoida u arhitekturi

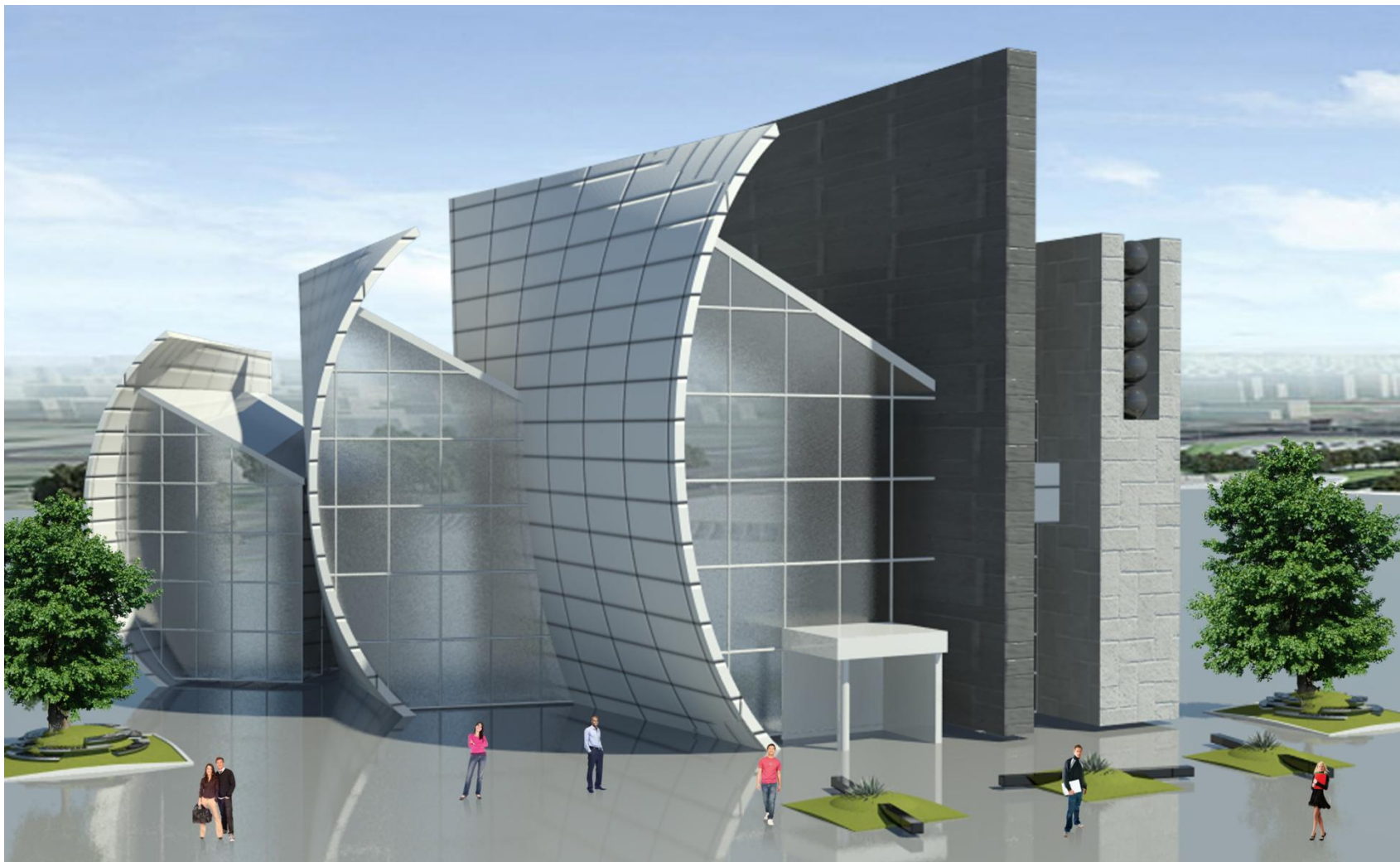

Ana Vasiljević, grafički rad, student, generacija 2010/11

Primena konoida u arhitekturi



Stefan Stanojević, grafički rad, student, generacija 2010/11

Primena konoida u arhitekturi

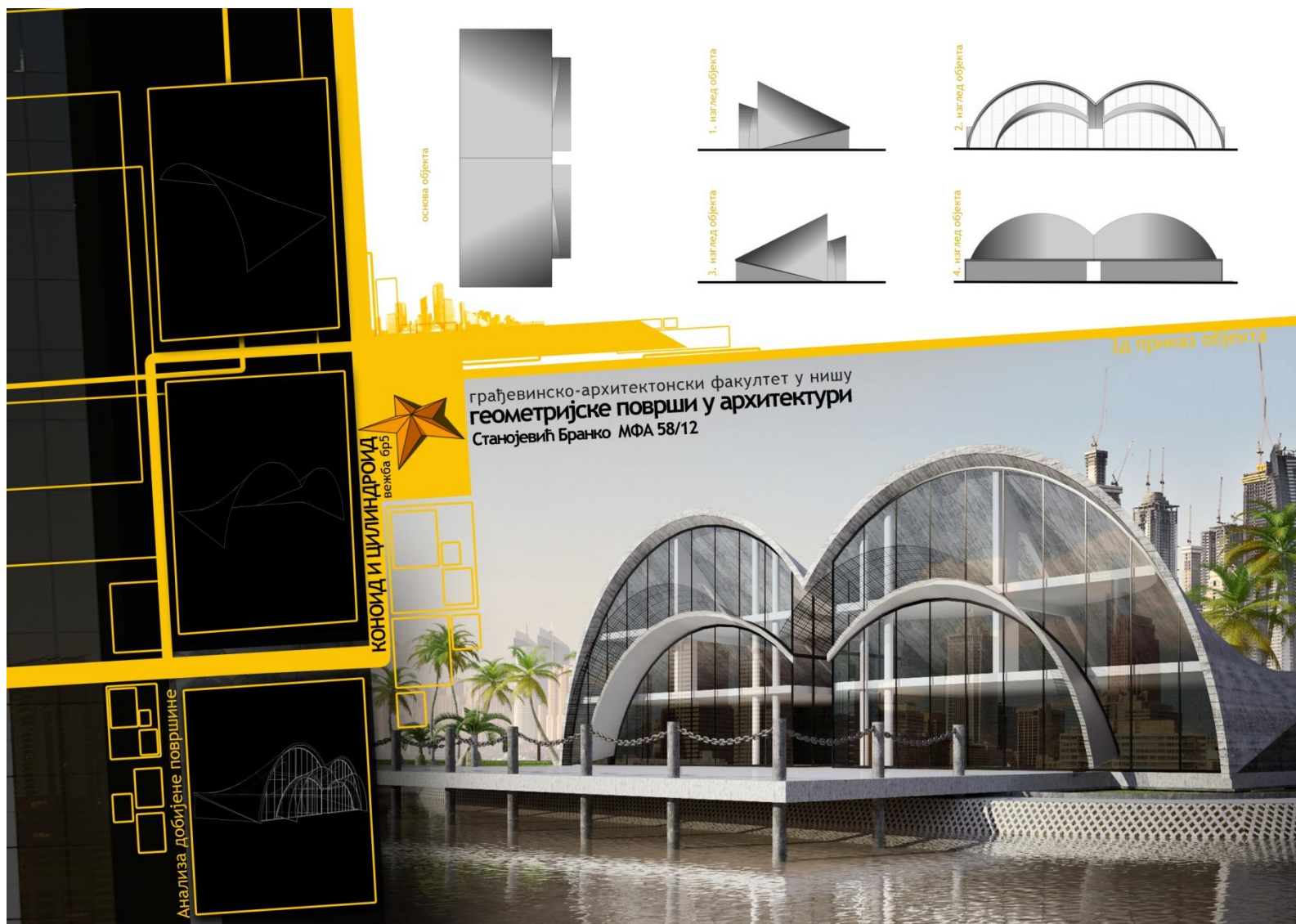

Branko Stanojević, grafički rad, student, generacija 2012/13

Primena konoida u arhitekturi

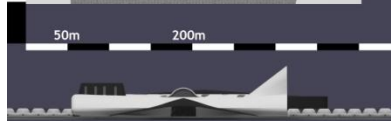

Dušan Lilić, grafički rad,
student, generacija 2012/13



Primena konoida u arhitekturi

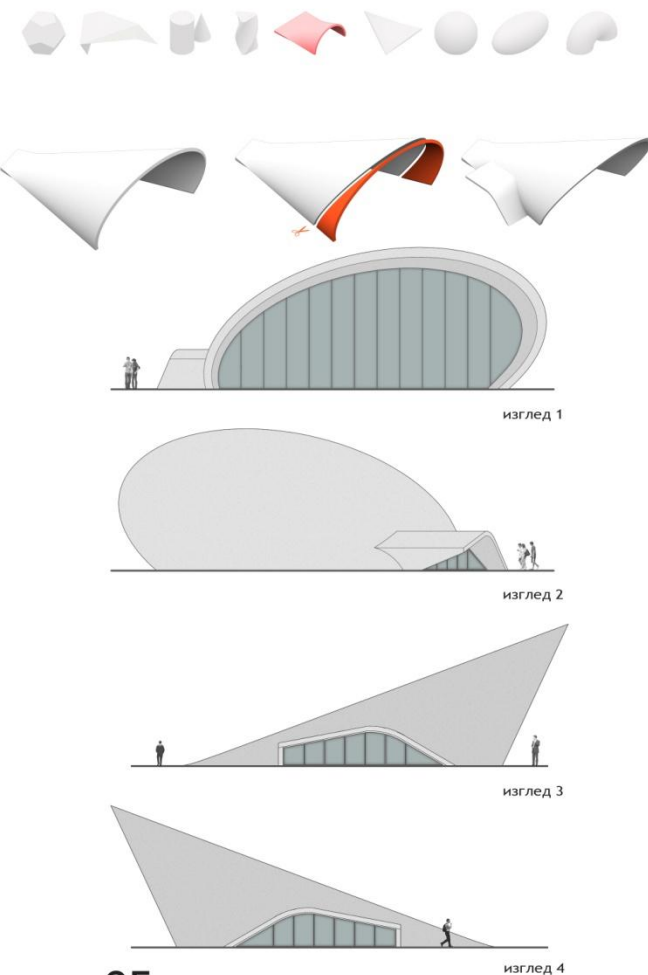

05



грађевинско-архитектонски факултет у нишу
геометријске површи у архитектури
милан брзакловић мра205/12

Primena konoida u arhitekturi

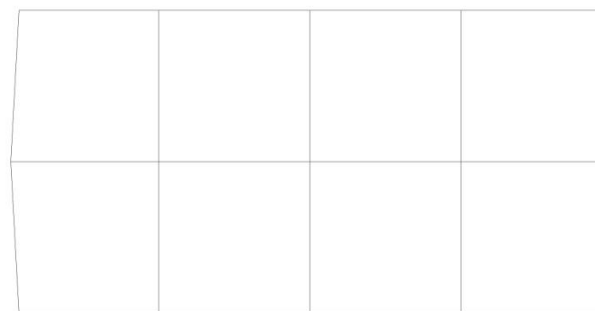
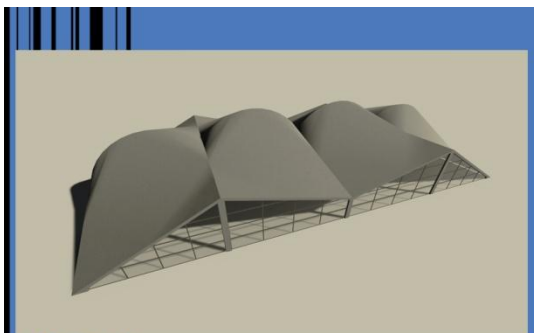

OSNOVA

RAZMERNIK 0 — 1 0

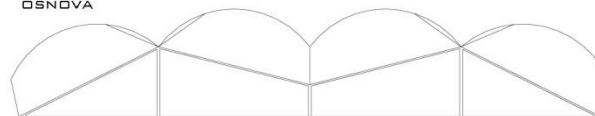
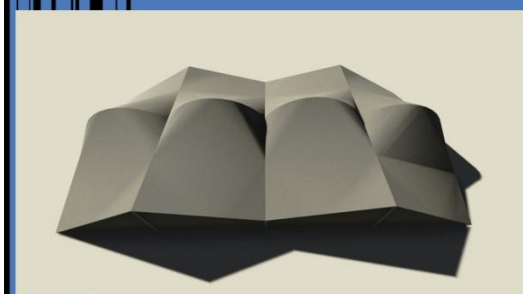

IZGLED 1

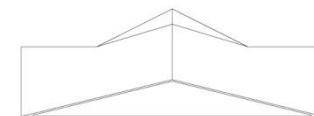

IZGLED 3

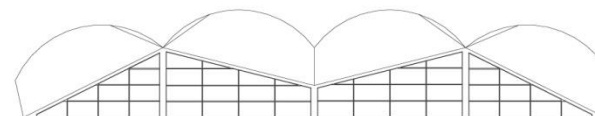
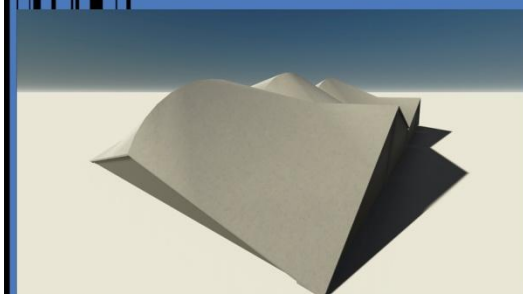

IZGLED 2

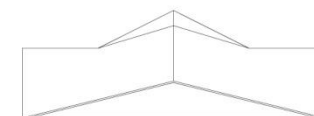

IZGLED 4



Primena konoida u arhitekturi

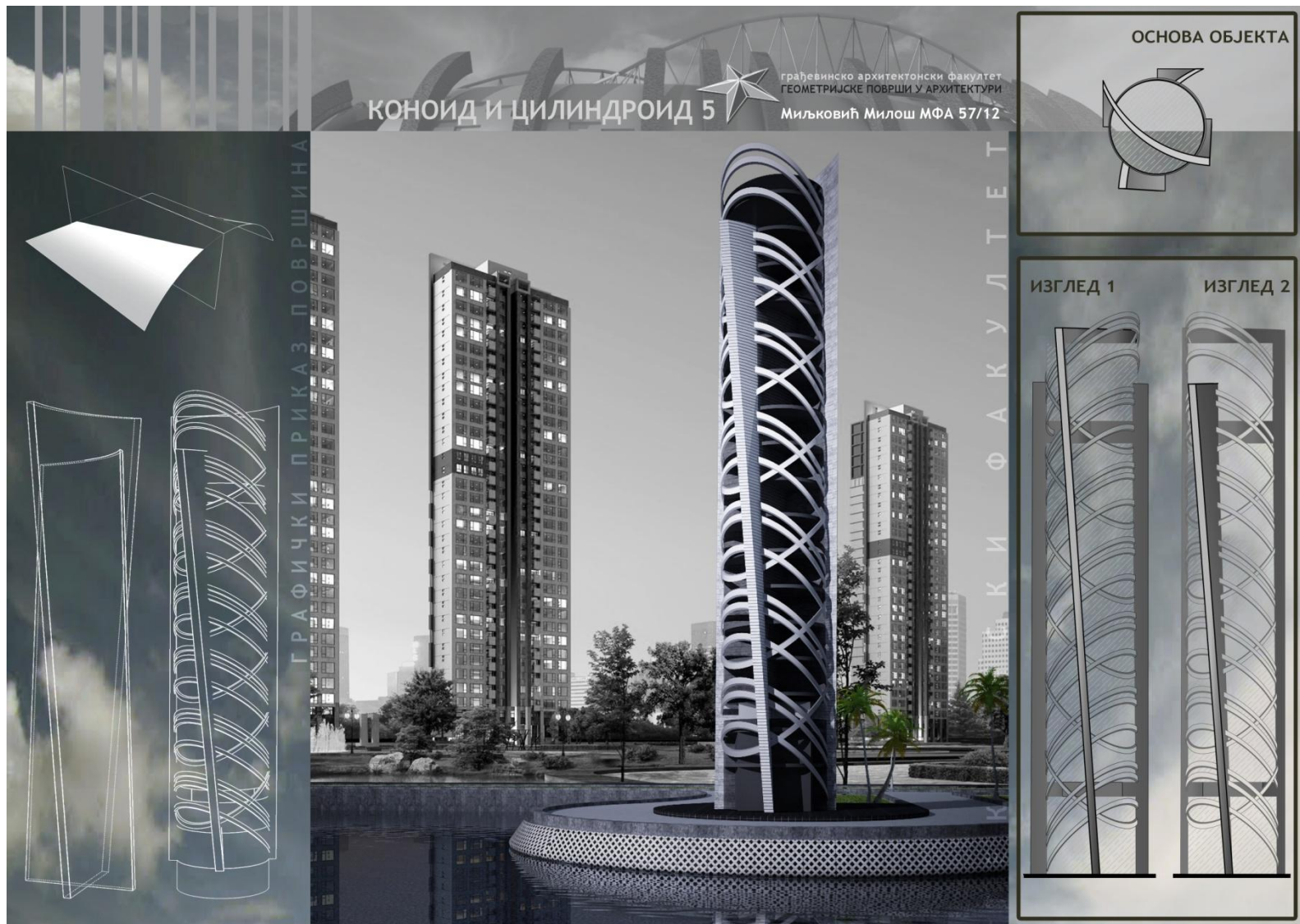

Miloš Miljković, grafički rad, student, generacija 2012/13

Primena konoida u arhitekturi

основа постоља за таблет, $p=1:5$

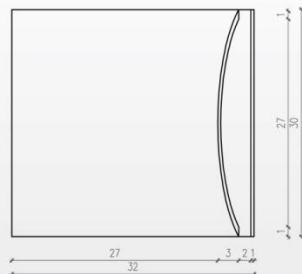

изглед постоља за таблет, $p=1:5$

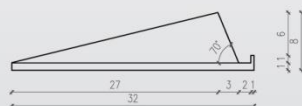

аксонометрија

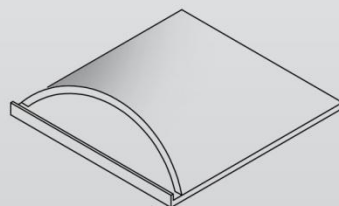

Primena konoida u arhitekturi

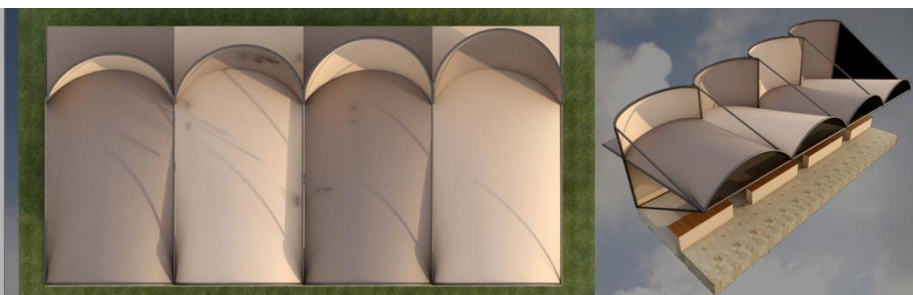
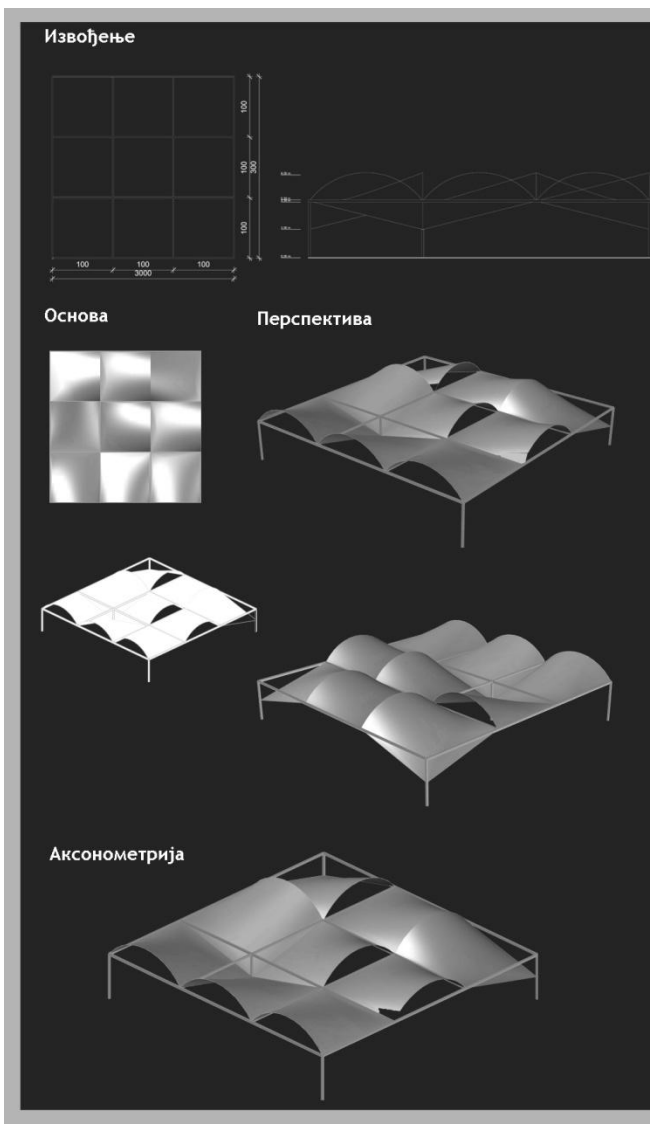

Надстрешница пијаце



Primena konoida u arhitekturi

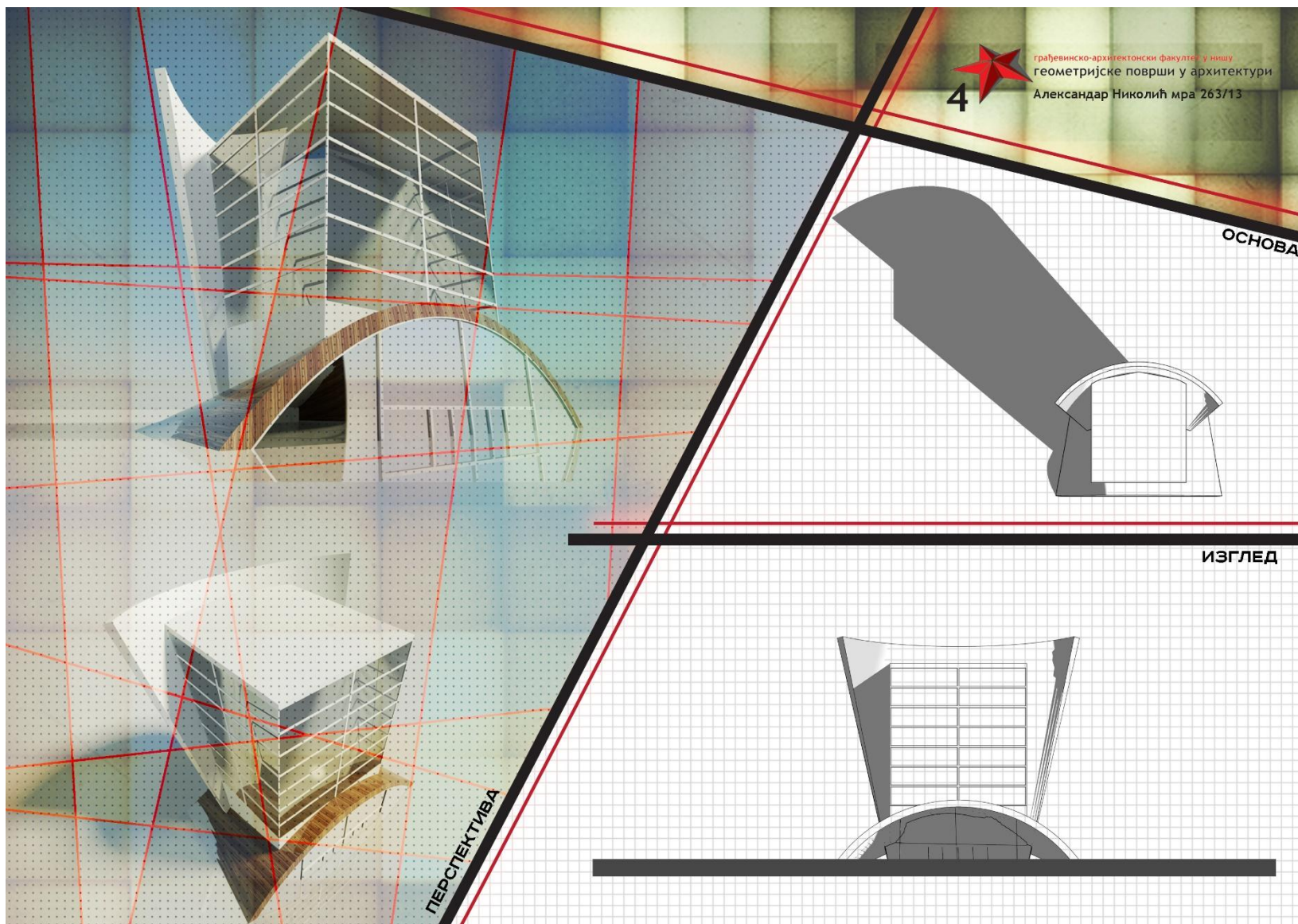

Primena konoida u arhitekturi



P= 1:10

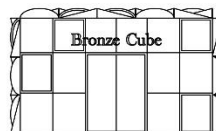
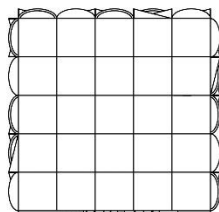

грађевинско-архитектонски факултет у нишу
геометријске површи у архитектури

Јована Илијев МРА 298/13



ОСНОВА

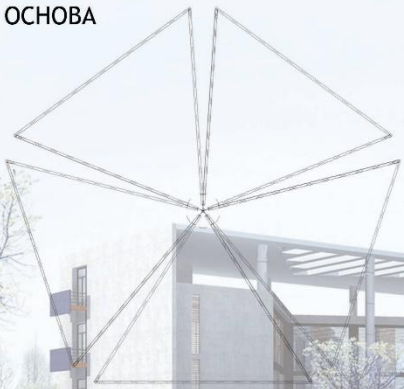

ФРОНТАЛНИ ПОГЛЕД

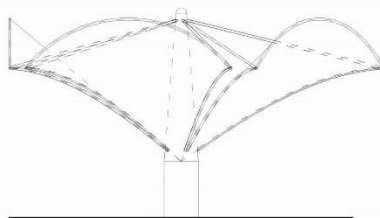

ПОГЛЕД СА СТРАНЕ

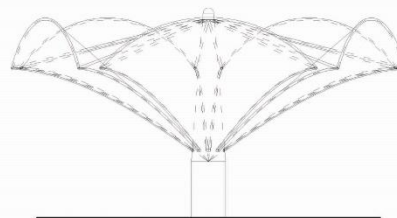

ШЕМАТСКИ ЗД ПРИКАЗ

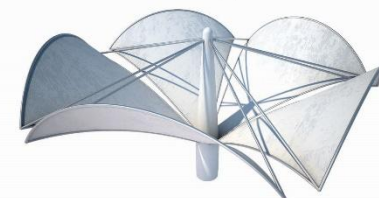

грађевинско-архитектонски факултет у нишу
геометријске површи у архитектури

Немања Љубеновић МФА 69/13

Primena konoida u arhitekturi

КОНОИД

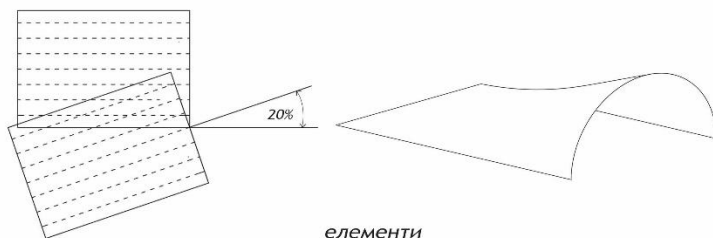
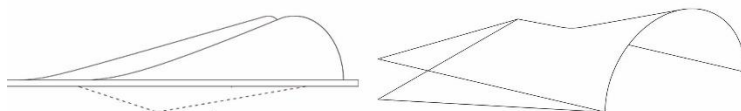

елементи

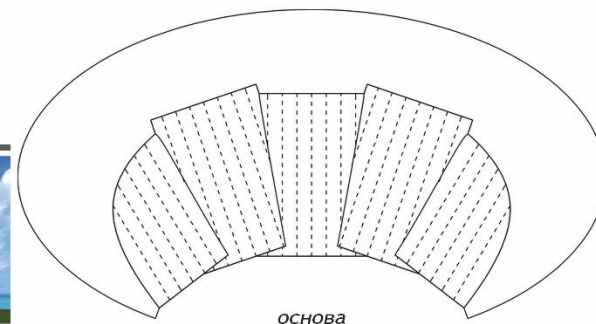
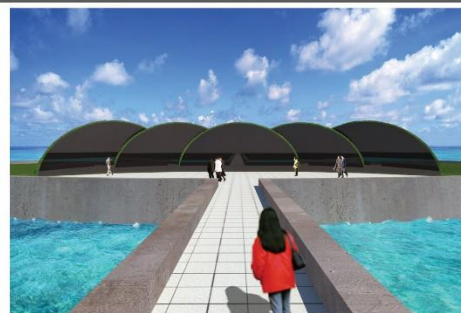
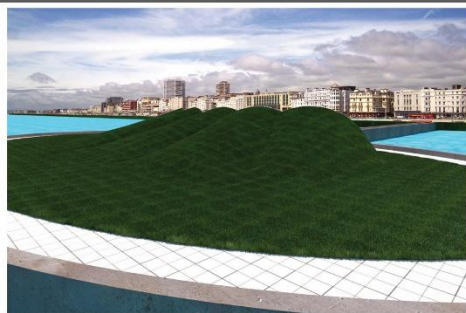
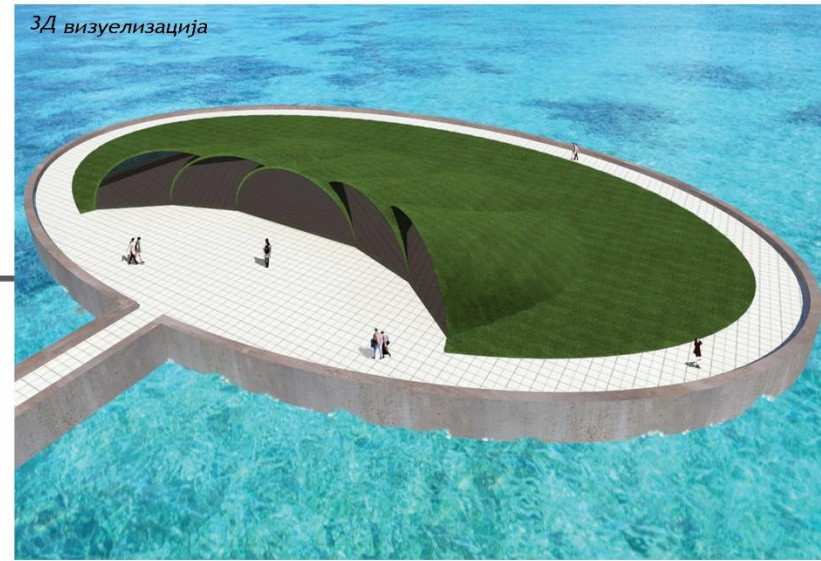

04



грађевинско-архитектонски факултет у нишу
геометријске површи у архитектури

Primena konoida u arhitekturi

КОНОИДИ

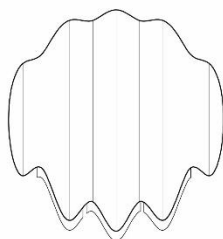
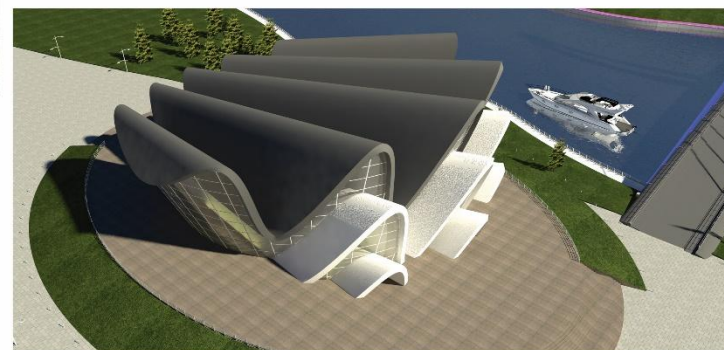
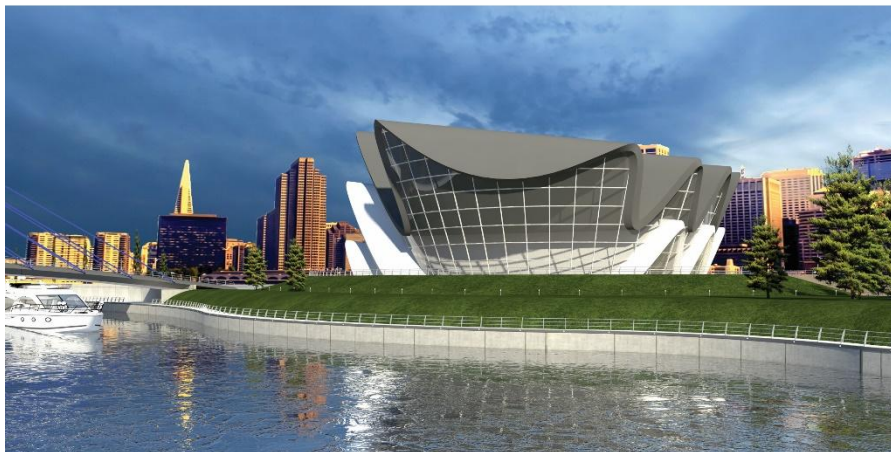
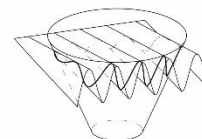

ОСНОВА

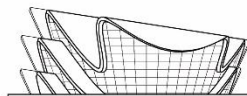

изглед 1



изглед 2



04



грађевинско-архитектонски факултет у нишу
геометријске површи у архитектури

Стефан Пешић МРА265/13

Primena konoida u arhitekturi

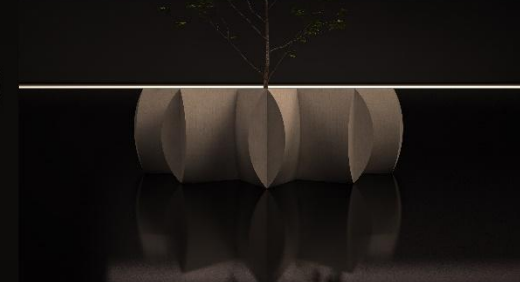
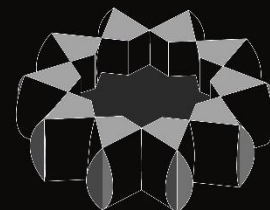
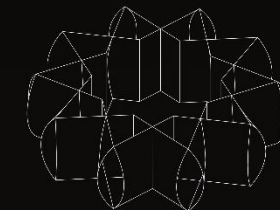
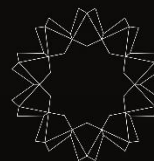

Ђорђе Јовић, граfiчки рад,
student, генерација 2014/15



Primena konoida u arhitekturi

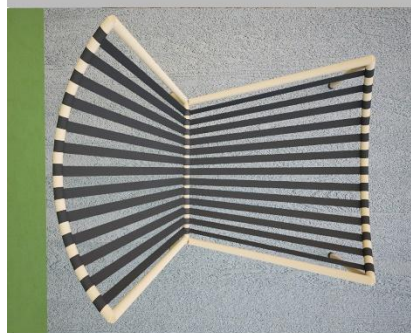

Ljiljana Đorđević, grafički rad,
student, generacija 2014/15



5. КОНОИД

основа објекта

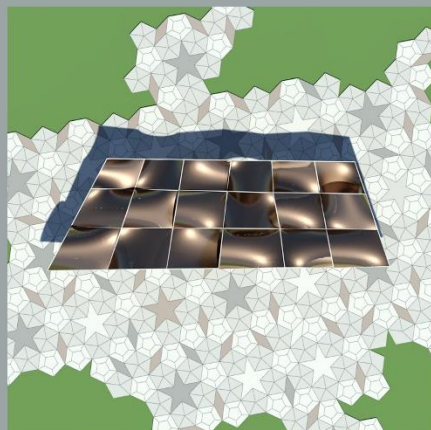

изглед објекта

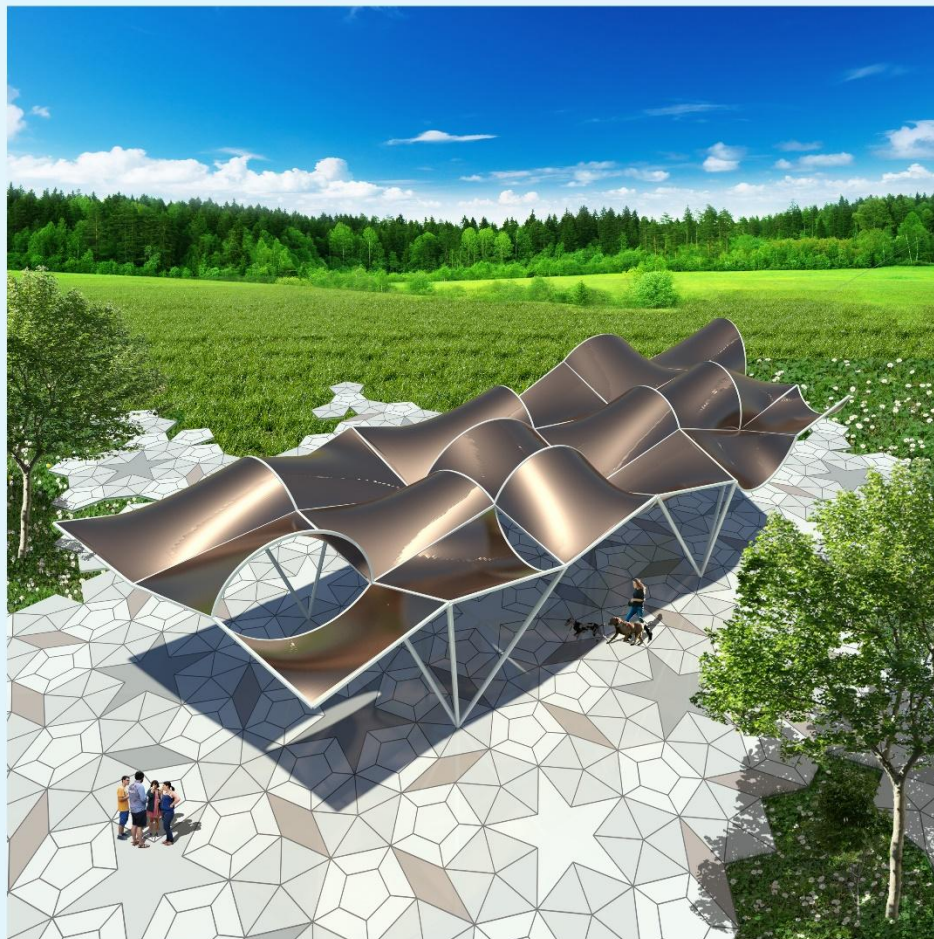
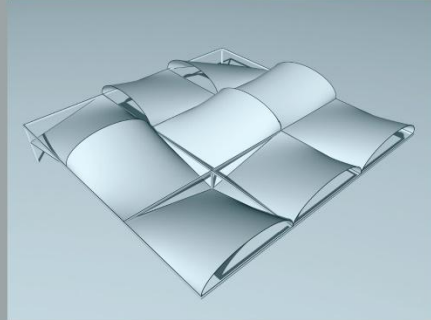

Primena konoida u arhitekturi

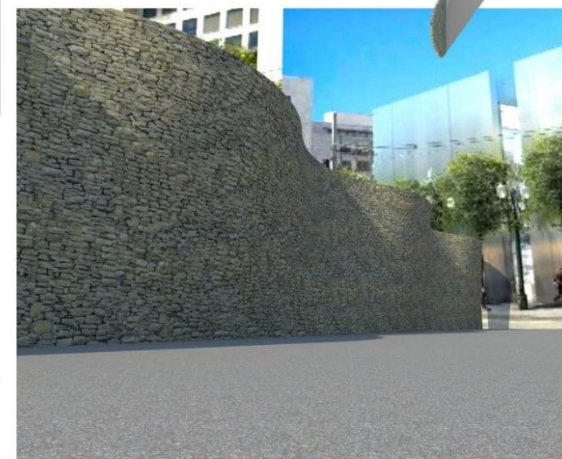
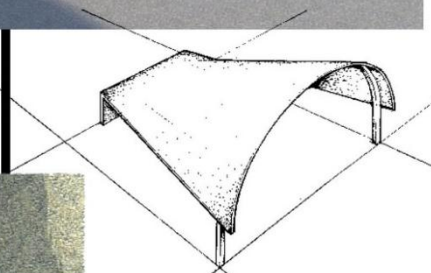
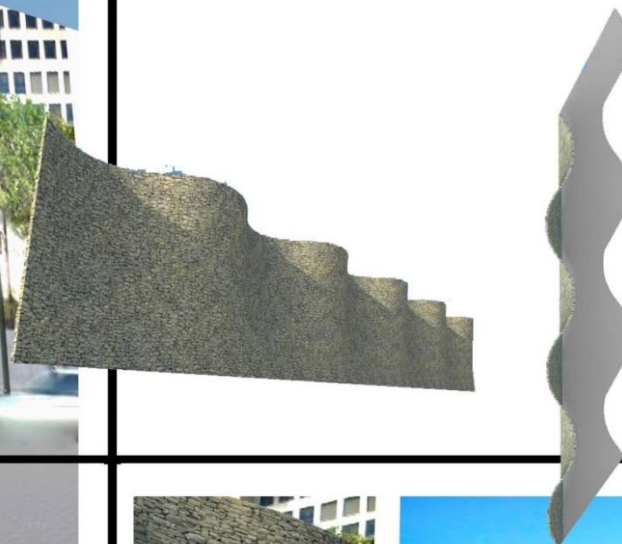

вежба **5** | **КОНОИД**



грађевинско-архитектонски факултет у нишу
геометријске површи у архитектури
Никоleta Милосављевић МРА 369/14

Nikoleta Milosavljević, grafički rad, student, generacija 2014/15



Literatura:

Geometrijske površi u arhitekturi, dr Sonja Krasić, Niš, Građevinsko-arhitektonski fakultet, 2012.g

Nacrtna geometrija, prof. Dr Miroslav Marković, Niš, 1998.g

Nacrtna geometrija, Anagnosti Petar, Naučna knjiga, Beograd, 1981.

Geometrija u graditeljstvu, Heinrich Brauner, Walter Kickingner, Školska knjiga, Zagreb, 1980.g

Geometria descriptiva superiory aplicada, Fernando I. Asensi, Editorial dossat. S.A. Madrid, 1975.g

Konstruktivni sistemi, Miodrag Nestorović, AF, Beograd ,2000.g

Konstruktivni sistemi, Desimir Dančević, GF, Niš, 1978.g

Crteži:

Vojislav Nikolić, student, gen. 2010/11

Petar Pejić, student, gen. 2010/11