

THE INTERNATIONAL CONFERENCE  
SYNERGY OF ARCHITECTURE & CIVIL ENGINEERING  
**SINARG 2023**

---

**PROCEEDINGS**

---

**VOLUME 2**



International Conference

**Synergy of  
Architecture &  
Civil Engineering**

Niš (SERBIA) - Science & Technology Park Niš - September 14-15, 2023

---

**PROCEEDINGS OF THE INTERNATIONAL CONFERENCE  
SYNERGY OF ARCHITECTURE & CIVIL ENGINEERING  
SINARG 2023**

**VOLUME 2**

**PUBLISHED BY:**

FACULTY OF CIVIL ENGINEERING AND ARCHITECTURE, UNIVERSITY OF NIŠ  
SERBIAN ACADEMY OF SCIENCES AND ARTS - BRANCH IN NIŠ

**FOR PUBLISHERS:**

SLAVIŠA TRAJKOVIĆ, PHD  
VLADA VELJKOVIĆ, PHD

**EDITORS:**

SLAVIŠA TRAJKOVIĆ, PHD  
VUK MILOŠEVIĆ, PHD

APPROVED TO BE PRINTED ON 7TH SEPTEMBER 2023. BY THE DECREE OF TEACHING SCIENTIFIC COUNCIL OF THE  
FACULTY OF CIVIL ENGINEERING AND ARCHITECTURE, UNIVERSITY OF NIŠ, NO. 8/181

APPROVED TO BE PRINTED ON 4TH SEPTEMBER 2023. BY THE COMMITTEE FOR MANAGING THE WORK OF THE  
SERBIAN ACADEMY OF SCIENCES AND ARTS - BRANCH IN NIŠ, NO. 1/23-159

**TECHNICAL EDITOR:** DUŠAN RANĐELOVIĆ, PHD

**COVER DESIGN:** LJILJANA JEVREMOVIĆ, PHD

**ISBN** 978-86-88601-81-8

**ISBN** 978-86-88601-82-5 (FOR PUBLISHING ISSUE)

**PRESS:** 100 COPIES

**PRINTED BY:** GRAFIKA GALEB NIŠ

**ORGANIZED BY:**

FACULTY OF CIVIL ENGINEERING AND ARCHITECTURE, UNIVERSITY OF NIŠ  
SERBIAN ACADEMY OF SCIENCES AND ARTS - BRANCH IN NIŠ  
SERBIAN ACADEMY OF SCIENCES AND ARTS - DEPARTMENT OF TECHNICAL SCIENCES

**IN PARTNERSHIP WITH**

SCIENCE TECHNOLOGY PARK NIŠ



**SCIENCE  
TECHNOLOGY  
PARK  
NIS**

*THE ORGANISATION OF THE INTERNATIONAL CONFERENCE*  
***SYNERGY OF ARCHITECTURE AND CIVIL ENGINEERING - SINARG 2023***  
*AND PRINTING OF THE PROCEEDINGS HAS BEEN SUPPORTED BY THE*  
***MINISTRY OF SCIENCE, TECHNOLOGICAL DEVELOPMENT AND INNOVATION,***  
***REPUBLIC OF SERBIA***  
*AND*  
***SERBIAN CHAMBER OF ENGINEERS.***



Ministry of Science, Technological  
Development and Innovation  
of the Republic of Serbia



ИНЖЕЊЕРСКА КОМОРА  
СРБИЈЕ

## SCIENTIFIC PROGRAM COMMITTEE

### CO-CHAIRS:

**Academician Dušan Teodorović**, PhD, Serbian Academy of Sciences and Arts, Belgrade, Serbia  
**Academician Branislav Mitrović**, Serbian Academy of Sciences and Arts, Belgrade, Serbia

### MEMBERS:

**Academician Fedor Mesinger**, PhD, Serbian Academy of Sciences and Arts, Belgrade, Serbia  
**Professor Günther Meschke**, PhD, Ruhr University, Bochum, Germany (Editor-in-Chief, Engineering Structures)  
**Professor Momcilo Markus**, PhD, University of Illinois, Urbana-Champaign, USA (Editor-in-Chief, JAWRA)  
**Professor Janos Logo**, PhD, BME University, Budapest, Hungary (Editor-in-Chief, Periodica Polytechnica Civil Engineering)  
**Professor Hartmut Pasternak**, PhD, Brandenburg University of Technology, Cottbus, Germany  
**Professor Sandra Klinge**, PhD, Technical University Berlin, Germany  
**Professor Naomi Ando**, PhD, Hosei University, Tokyo, Japan  
**Associate Professor Zakhar Maletskiy**, PhD, Norwegian University of Life Sciences (NMBU), As, Norway  
**Senior Lecturer Milena Metalkova-Markova**, PhD, University of Portsmouth, Portsmouth, United Kingdom  
**Associate Professor Oliveir Gaudin**, PhD, Ecole Nature et Paysage / INSA Centre Val de Loire, Blois, France  
**Adjunct Professor Giuseppe Tito Aronica**, PhD, University of Messina, Italy  
**Adjunct Professor Elena Lucchi**, PhD, Politecnico di Milano, Italy  
**Associate Professor Michael Tritthart**, PhD, University of Natural Resources (BOKU), Wien, Austria  
**Professor Georgios E. Stavroulakis**, PhD, Technical University of Crete, Chania, Greece  
**Research Associate Charalampos Skoulikaris**, PhD, Aristotle University of Thessaloniki, Greece  
**Associate Professor Janusz Marchwiński**, PhD, University of Ecology and Management, Warsaw, Poland  
**Assistant Professor Monika Magdziak**, PhD, Białystok University of Technology, Poland  
**Associate Professor Martin Horáček**, PhD, Brno University of Technology, Czech Republic  
**Professor Martina Zelenakova**, PhD, Technical University of Kosice, Slovakia  
**Professor Beatrice-Gabriela Jöger**, PhD, Ion Mincu University of Architecture and Urbanism, Bucharest, Romania  
**Research Associate Constanta Carmina Gheoghita**, PhD, Technical University of Iasi, Romania  
**Associate Professor Petar Filkov**, PhD, University of Architecture, Civil Engineering and Geodesy (UACG), Sofia, Bulgaria  
**Associate Professor Stefan Asparuhov**, PhD, University of Architecture, Civil Engineering and Geodesy (UACG), Sofia, Bulgaria  
**Associate Professor Filiz Karakuş**, PhD, Ankara Yildirim Beyazit University, Ankara, Türkiye  
**Senior Lecturer Jan-Frederik Flor**, PhD, University of Malaysia, Kelantan, Malaysia  
**Associate Professor Davorin Penava**, PhD, University of Osijek, Croatia  
**Professor Barbara Karleuša**, PhD, University of Rijeka, Croatia  
**Associate Professor Darija Gajić**, PhD, University of Banja Luka, Bosnia and Herzegovina  
**Professor Emina Hadžić**, PhD, University of Sarajevo, Bosnia and Herzegovina  
**Professor Adnan Ibrahimović**, PhD, University of Tuzla, Bosnia and Herzegovina  
**Professor Biljana Šćepanović**, PhD, University of Montenegro, Podgorica, Montenegro  
**Professor Goran Sekulić**, PhD, University of Montenegro, Podgorica, Montenegro  
**Professor Goran Markovski**, PhD, Ss. Cyril and Methodius University, Skopje, North Macedonia  
**Professor Milorad Jovanovski**, PhD, Ss. Cyril and Methodius University, Skopje, North Macedonia  
**Professor Aneta Hristova Popovska**, PhD, Ss. Cyril and Methodius University, Skopje, North Macedonia  
**Associate Professor Aleksandar Radevski**, PhD, Ss. Cyril and Methodius University, Skopje, North Macedonia  
**Professor Vlatko Šešov**, PhD, Institute of Earthquake Engineering and Engineering Seismology, Skopje, North Macedonia  
**Professor Vladan Kuzmanović**, PhD, University of Belgrade, Serbia  
**Professor Vladimir Lojanica**, University of Belgrade, Serbia  
**Professor Srdjan Kolaković**, PhD, University of Novi Sad, Serbia  
**Professor Slaviša Trajković**, PhD, University of Niš, Serbia  
**Research Professor Saša Milijić**, PhD, Institute of Architecture and Urban & Spatial Planning of Serbia (IAUS), Belgrade, Serbia  
**Senior research fellow Sanja Simonović Alfirević**, PhD, IAUS, Belgrade, Serbia  
**Research Professor Nenad Šušić**, PhD, Institute for testing materials (IMS), Belgrade, Serbia  
**Professor Milan Gocić**, PhD, University of Niš, Serbia

□

## ORGANIZING COMMITTEE

### CO-CHAIRS:

**SASA Corresponding Member Vlada Veljković**, PhD, Serbian Academy of Sciences and Arts, Branch in Niš, Serbia  
**Professor Slaviša Trajković**, PhD, Faculty of Civil Engineering and Architecture, University of Niš, Serbia

### MEMBERS:

**Professor Zoran Bonić**, PhD, Faculty of Civil Engineering and Architecture, University of Niš, Serbia  
**Professor Dragan Žunić**, PhD, Activities Coordinator in SASA Branch in Niš, Serbia  
**Milan Randjelović**, PhD, CEO, Science Technology Park Niš, Serbia  
**Boban Veličković**, MSc, Deputy CEO, Building Directorate of Serbia  
**Professor Zlatko Zafirovski**, PhD, Faculty of Civil Engineering, Ss. Cyril and Methodius University, Skopje, North Macedonia  
**Professor Miroslav Marjanovic**, PhD, Faculty of Civil Engineering, University of Belgrade, Serbia  
**Professor Igor Pesko**, PhD, Faculty of Technical Sciences, University of Novi Sad, Serbia  
**Senior Research Fellow Božidar Manić**, PhD, Institute of Architecture and Urban & Spatial Planning of Serbia (IAUS), Belgrade, Serbia  
**Professor of Applied Sciences Nenad Stojković**, PhD, Academy of Applied Technical and Educational Studies in Niš, Serbia  
**Associate Research Professor Milan Stojković**, PhD, Institute for Artificial Intelligence of Serbia, Novi Sad, Serbia  
**Professor Snežana Djorić-Veljković**, PhD, Faculty of Civil Engineering and Architecture, University of Niš, Serbia  
**Associate Professor Vuk Milošević**, PhD, Faculty of Civil Engineering and Architecture, University of Niš, Serbia  
**Assistant Professor Ljiljana Jevremović**, PhD, Faculty of Civil Engineering and Architecture, University of Niš, Serbia  
**Professor Marina Mijalković**, PhD, Faculty of Civil Engineering and Architecture, University of Niš, Serbia  
**Professor Zoran Grdić**, PhD, Faculty of Civil Engineering and Architecture, University of Niš, Serbia  
**Associate Professor Nenad Ristić**, PhD, Faculty of Civil Engineering and Architecture, University of Niš, Serbia  
**Associate Professor Elefterija Zlatanović**, PhD, Faculty of Civil Engineering and Architecture, University of Niš, Serbia  
**Assistant Professor Miodir Miljković**, PhD, University of Niš, Serbia  
**Associate Professor Žarko Petrović**, PhD, Faculty of Civil Engineering and Architecture, University of Niš, Serbia  
**Professor Ljiljana Vasilevska**, PhD, Faculty of Civil Engineering and Architecture, University of Niš, Serbia  
**Professor Danica Stanković**, PhD, Faculty of Civil Engineering and Architecture, University of Niš, Serbia  
**Professor Sonja Kراسić**, PhD, Faculty of Civil Engineering and Architecture, University of Niš, Serbia  
**Professor Dragan Kostić**, PhD, Faculty of Civil Engineering and Architecture, University of Niš, Serbia  
**Professor Miodir Vasov**, PhD, Faculty of Civil Engineering and Architecture, University of Niš, Serbia  
**Associate Professor Aleksandar Milojković**, PhD, Faculty of Civil Engineering and Architecture, University of Niš, Serbia  
**Associate Professor Marko Nikolić**, PhD, Faculty of Civil Engineering and Architecture, University of Niš, Serbia  
**Assistant Professor Dušan Randelović**, PhD, Faculty of Civil Engineering and Architecture, University of Niš, Serbia  
**Assistant Professor Radovan Cvetković**, PhD, Faculty of Civil Engineering and Architecture, University of Niš, Serbia  
**Associate Professor Milica Marković**, PhD, Faculty of Civil Engineering and Architecture, University of Niš, Serbia  
**Associate Professor Srdjan Zivković**, PhD, Faculty of Civil Engineering and Architecture, University of Niš, Serbia  
**Associate Professor Milena Dinić-Branković**, PhD, Faculty of Civil Engineering and Architecture, University of Niš, Serbia  
**Associate Professor Ana Momčilović-Petronijević**, PhD, Faculty of Civil Engineering and Architecture, University of Niš, Serbia

## LOCAL ORGANIZING TEAM

### CHAIR:

**Professor Zoran Bonić**, PhD, Faculty of Civil Engineering and Architecture, University of Niš, Serbia

### MEMBERS:

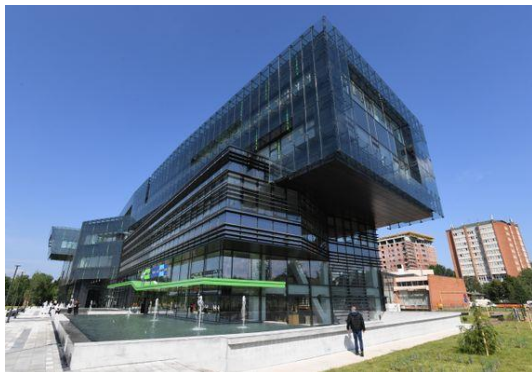
**Associate Professor Vuk Milošević**, PhD, Faculty of Civil Engineering and Architecture, University of Niš, Serbia  
**Assistant Professor Ljiljana Jevremović**, PhD, Faculty of Civil Engineering and Architecture, University of Niš, Serbia  
**Professor Snežana Djorić-Veljković**, PhD, Faculty of Civil Engineering and Architecture, University of Niš, Serbia  
**Associate Professor Nenad Ristić**, PhD, Faculty of Civil Engineering and Architecture, University of Niš, Serbia  
**Assistant Professor Dušan Randelović**, PhD, Faculty of Civil Engineering and Architecture, University of Niš, Serbia  
**Teach. Ass. Milica Igić**, PhD, Faculty of Civil Engineering and Architecture, University of Niš, Serbia  
**Teach. Ass. Aleksandar Djordjević**, Faculty of Civil Engineering and Architecture, University of Niš, Serbia  
**Teach. Ass. Nemanja Marinković**, Faculty of Civil Engineering and Architecture, University of Niš, Serbia

---

## CONFERENCE TOPICS

- ✓ *URBAN AND SPATIAL PLANNING*
- ✓ *PLANNING AND DESIGNING SMART AND RESILIENT CITIES*
- ✓ *URBAN AND ARCHITECTURAL DESIGN - THEORY AND PRACTICE*
- ✓ *ARCHITECTURAL DESIGN AND ANALYSIS*
- ✓ *ARCHITECTURE AND BUILT ENVIRONMENT*
- ✓ *BIOClimatic AND BIOPHILIC ARCHITECTURE*
- ✓ *PRINCIPLES OF ECOLOGICAL DESIGN AND CONSTRUCTION*
- ✓ *BUILT HERITAGE PROTECTION AND MANAGEMENT*
- ✓ *BUILDING RENOVATION AND RECYCLING*
- ✓ *ARCHITECTURAL ENGINEERING*
- ✓ *BUILDING INFORMATION MODELING (BIM)*
- ✓ *STRUCTURAL ENGINEERING*
- ✓ *MATERIALS IN CIVIL ENGINEERING AND ARCHITECTURE*
- ✓ *ENGINEERING MECHANICS*
- ✓ *WATER RESOURCES MANAGEMENT*
- ✓ *HIGHWAY ENGINEERING*
- ✓ *GEOTECHNICAL ENGINEERING*
- ✓ *CONSTRUCTION ENGINEERING AND MANAGEMENT*
- ✓ *PROJECT MANAGEMENT*
- ✓ *CIRCULAR ENGINEERING*
- ✓ *ENTREPRENEURSHIP AND ENGINEERING*
- ✓ *TRANSPORTATION RESEARCH AND DEVELOPMENT*
- ✓ *CLIMATE CHANGE CHALLENGES IN ENGINEERING*
- ✓ *DISASTER RISK MANAGEMENT*

## CONFERENCE VENUE



International Conference

**Synergy of  
Architecture &  
Civil Engineering**

Niš (SERBIA) - Science & Technology Park Niš - September 14-15, 2023

## **PREFACE**

*The primary goal of the SINARG 2023 conference is to present contemporary achievements in the scientific and practical aspects of architecture and civil engineering. The organizers of the conference aimed to facilitate the participation of both national and international professionals in theoretical and experimental research related to the processes of design, project management, construction, and building maintenance within the construction industry.*

*Simultaneously, this scientific conference serves as a platform for exchanging experiences and information regarding innovations and advancements in planning, design, new materials, and construction and reconstruction technologies within the fields of architecture and civil engineering.*

*Therefore, this conference should serve as a forum where experts from civil engineering, architecture, and other related fields have the opportunity to present the results of their research. In that context, conference topics have been carefully selected to provide focus on current issues in the field and encourage productive discussion bringing fresh and original insights and concepts to the forefront.*

*More than 180 paper proposals have been submitted to the conference. A single-blind review process was used to assess the full papers. The reviewers are esteemed scientists holding PhD degrees in the same field as the paper's topic. There are more than 70 reviewers from ten countries who have significantly contributed to the scientific quality of the conference, and their names are printed in the proceedings.*

*A total of 142 full papers have been accepted for publication. Some of the papers have been selected for publication in our journals, with nineteen papers in *Facta Universitatis: Architecture and Civil Engineering* and nine in the *Journal of the Faculty of Civil Engineering and Architecture*. The conference proceedings consist of 114 papers divided into two volumes.*

*The total number of authors and co-authors accepted for publishing at SINARG 2023 exceeds 320. Out of this number, more than 80 authors come from abroad, representing 19 countries (Albania, Bosnia and Herzegovina, Bulgaria, Croatia, Germany, Greece, Hungary, India, Indonesia, Netherlands, North Macedonia, Montenegro, Oman, Poland, Romania, Serbia, Slovakia, Turkey, United Kingdom).*

*The editors express their gratitude to all the authors for their participation and to the reviewers for their valuable comments, which have contributed to the improvement of the original manuscripts and have enhanced the overall quality of the conference..*

## CONTENTS

### **PREFACE**

57.	<b>CLASSIFICATION OF RAILWAY SUPERSTRUCTURE RECONSTRUCTION METHODS</b>	<b>597</b>
	<i>JELENA DIMITRIJEVIĆ, ZLATKO ZAFIROVSKI</i>	
58.	<b>COMPARISON OF DAILY AND MONTHLY REFERENCE EVAPOTRANSPIRATION IN AN URBAN AREA</b>	<b>607</b>
	<i>MLADEN MILANOVIĆ, SLAVISA TRAJKOVIC, MILAN GOCIC, MARTINA ZELENKOVA, HANY F. ABD-ELHAMID</i>	
59.	<b>EARTHQUAKE RESISTANCE OF PILE FOUNDATIONS</b>	<b>614</b>
	<i>BORKO MILADINOVIC, ZVONKO TOMANOVIC</i>	
60.	<b>ANALYSIS OF THE BEARING CAPACITY OF A MASONRY WALL UNDER THE ACTION OF AN EARTHQUAKE THAT HAPPENED IN TURKEY IN 2023</b>	<b>625</b>
	<i>FARIS TREŠNJO</i>	
61.	<b>MARKETING SPECIALIZED IN THE FIELD OF CONSTRUCTION AND ARCHITECTURE TO CREATE AN INTERACTIVE RELATIONSHIP IN THE REAL ESTATE MARKET</b>	<b>636</b>
	<i>LJILJANA STOŠIĆ MIHAJLOVIĆ, MARIJA MIHAJLOVIĆ</i>	
62.	<b>CONSTRUCTION AND DEMOLITION WASTE MANAGEMENT IN SERBIA</b>	<b>647</b>
	<i>IVAN STOJKOVIĆ, PREDRAG STANKOVIĆ, MILICA TRPKOVA</i>	
63.	<b>PREISACH MODEL FOR INNER HYSTERESIS LOOPS OF CYCLICLY LOADED MILD STEEL ELEMENTS</b>	<b>659</b>
	<i>PETAR KNEŽEVIĆ, ALEKSANDAR RADAKOVIĆ, NIKOLA VELIMIROVIĆ, ZORAN PEROVIĆ, NENAD STOJKOVIĆ</i>	
64.	<b>THE POSSIBILITY OF IMPROVING THE ARCHITECTURAL DESIGN OF COMMUNAL AND CIRCULATION AREAS IN PRESCHOOLS USING THE SPACE SYNTAX METHOD</b>	<b>667</b>
	<i>SOFIJA ICKOVSKI, MILAN TANIĆ</i>	
65.	<b>ARTS AND ARCHITECTURAL COLLABORATIONS IN ATHENS OF THE SIXTIES (60S)</b>	<b>678</b>
	<i>DIMITRIS GRIGORIOU</i>	
66.	<b>EXTENDING THE LIFE OF RESIDENTIAL BUILDINGS THROUGH ADAPTATION: A CASE STUDY OF NIŠ, SERBIA</b>	<b>690</b>
	<i>BRANISLAVA STOILJKOVIĆ, HRISTINA KRSTIĆ, NATAŠA PETKOVIĆ, VLADANA PETROVIĆ</i>	
67.	<b>RIVER TRAINING WORKS WITH THE AIM OF FLUVIAL PROCESSES CONTROL THROUGH THE SEDIMENT TRANSPORT AND DEFORMATION OF THE RIVER BED ANALYSIS</b>	<b>701</b>
	<i>ALEKSANDRA ILIĆ, ILIJA ILIĆ, DRAGAN RADIVOJEVIĆ, BORKO RADIVOJEVIĆ</i>	
68.	<b>ANALYSIS OF THE INTERACTION BETWEEN THE FOUNDATION SLAB AND THE SOIL IN A MULTI-STOREY REINFORCED CONCRETE BUILDING</b>	<b>713</b>
	<i>MARIJANA JANIČIJEVIĆ, STEFAN MIHAJLOVIĆ</i>	
69.	<b>EXPLORING THE POSSIBILITY OF CONNECTING THE GAME ENGINE AND GIS AS MEANS OF DECISION SUPPORT IN URBAN PLANNING</b>	<b>723</b>
	<i>PETAR VRANIĆ, DUŠAN TATIĆ</i>	
70.	<b>LARGE HOUSING ESTATES IN POST-SOCIALIST PERIOD: DEVELOPMENT STRATEGIES AND PRACTICE</b>	<b>733</b>
	<i>JELENA ĐEKIĆ, MILENA DINIĆ BRANKOVIĆ, MILICA LJUBENOVIĆ, MILICA IGIĆ, MIHAILO MITKOVIĆ</i>	
71.	<b>"ERASING" THE BOUNDARY BETWEEN INTERNAL AND EXTERNAL SPACES IN PRESCHOOL FACILITIES</b>	<b>745</b>
	<i>ALEKSANDRA RANČIĆ, DANICA STANKOVIĆ, ALEKSANDRA CVETANOVIĆ</i>	
72.	<b>THE WAY OF BEAUTY - ARCHITECTURE AS A QUASI-OBJECT BETWEEN CONSUMPTION AND SUSTAINABILITY</b>	<b>756</b>
	<i>MILENA METALKOVA-MARKOVA</i>	
73.	<b>AFFIRMING THE CONCEPT OF CONTINUITY IN THE MODERNIST HERITAGE THROUGH THE NOTION OF BORDER: CASE STUDY OF THE MEANDER BUILDINGS IN NEW BELGRADE'S BLOCK 23</b>	<b>765</b>
	<i>VANJA SPASENOVIĆ, BOJANA SIĆOVIĆ</i>	
74.	<b>COOPERATION BETWEEN ARCHITECTS AND STRUCTURAL ENGINEERS IN THE DESIGN OF COMPLEX STRUCTURES – THE REVIEW</b>	<b>777</b>
	<i>MILOŠ ČOKIĆ, RUŽICA KOVAČEVIĆ, RADOMIR FOLIĆ, NADJA KURTOVIĆ FOLIĆ</i>	



---

75.	<b>QUANTITATIVE CHARACTERISTICS OF HIGH INTENSITY RAINFALL IN THE VICINITY OF THE CITY OF NIS</b>	<b>789</b>
	<i>STEVAN PROHASKA, ALEKSANDRA ILIĆ, OGNJEN PROHASKA, VLADISLAVA BARTOŠ DIVAC</i>	
76.	<b>STABILITY OF COMPRESSED CHORD OF HALF-THROUGH TRUSS GIRDERS IN BRIDGE CONSTRUCTION ACCORDING TO EUROCODE WITH CASE STUDY</b>	<b>799</b>
	<i>ALEKSANDAR STOJANOVIĆ, JOVAN ANĐELKOVIĆ</i>	
77.	<b>PUBLIC PARTICIPATION SUPPORTING URBAN SUSTAINABILITY TRANSITION: RECENT EXPERIENCES FROM PLANNING AND GOVERNANCE PRACTICE IN SERBIAN CITIES</b>	<b>808</b>
	<i>NATASA ČOLIĆ, MARINA NENKOVIĆ-RIZNIC, MARIJANA PANTIC</i>	
78.	<b>OCCUPATIONAL SAFETY AND HEALTH IN CONSTRUCTION INDUSTRY – CHALLENGES OF MODERN LABOR LEGISLATION AND PRACTICE</b>	<b>819</b>
	<i>ALEKSANDRA ILIĆ PETKOVIĆ, IVAN MIJAILOVIĆ</i>	
79.	<b>DEFLECTIONS OF BARREL VAULT SHAPED MEMBRANE MODEL UNDER EXTERNAL LOADS</b>	<b>827</b>
	<i>VUK MILOŠEVIĆ, DRAGAN KOSTIĆ, MIOMIR VASOV, DUŠAN RANĐELOVIĆ, JANUSZ MARCHWIŃSKI</i>	
80.	<b>BIOPHILIC DESIGN PRINCIPLES IN WORKPLACE</b>	<b>837</b>
	<i>STELA SKRIZHOVSKA-KOLEVA</i>	
81.	<b>THE LARGE-SCALE COLLECTIVE HOUSING OF SOCIALIST YUGOSLAVIA – THE INTRODUCTION AND DEVELOPMENT OF A NEW WAY OF CITY LIFE</b>	<b>846</b>
	<i>VIOLETA STEFANOVIĆ</i>	
82.	<b>INVESTIGATION OF THE POSSIBILITIES OF USING “BUZZI-SPACE” APPLICATION IN ORDER TO PREDICT REVERBERATION TIME</b>	<b>855</b>
	<i>PREDRAG RADOMIROVIĆ</i>	
83.	<b>POSSIBILITIES OF ABSENTEE LEARNING IN ARCHITECTURAL DESIGN</b>	<b>864</b>
	<i>NIKOLAY ISTATKOV</i>	
84.	<b>FATIGUE LIFE PREDICTION OF ADHESIVELY BONDED JOINTS BASED ON STIFFNESS DEGRADATION</b>	<b>875</b>
	<i>NENAD STOJKOVIĆ, PETAR KNEŽEVIĆ, NIKOLA VELIMIROVIĆ, NEMANJA MARKOVIĆ</i>	
85.	<b>TOWARDS NUMERICAL ARCHITECTURAL ORDER IDENTIFICATION: EXPRESSING CAPITAL MORPHOLOGY BY USING DYNAMICS OF ITS PARAMETERS</b>	<b>886</b>
	<i>DJORDJE MITROVIĆ, DJORDJE DJORDJEVIĆ, MIRJANA DEVETAKOVIĆ, GORDANA DJUKANOVIĆ</i>	
86.	<b>SOME SIGNIFICANT ACHIEVEMENTS OF CONCRETE STRUCTURES</b>	<b>898</b>
	<i>NADJA KURTOVIĆ FOLIĆ, RADOMIR FOLIĆ, MILOŠ ČOKIĆ</i>	
87.	<b>GEOMETRY AND FORM IN FUNCTION OF INTERIOR SPACE AND OUTER APPEARANCE</b>	<b>910</b>
	<i>JOVANA VUKANIĆ, VLADAN NIKOLIĆ, JASMINA TAMBURIĆ, OLIVERA NIKOLIĆ, SANJA SPASIĆ ĐORĐEVIĆ</i>	
88.	<b>HYDROTECHNICAL TUNNELS AT DAMS</b>	<b>916</b>
	<i>ZLATKO ZAFIROVSKI, MARIJA PETKOVSKA</i>	
89.	<b>ANALYSIS OF PHASES AND STEPS OF THE ISO 22370 STANDARD IN PLANNING AND DESIGNING SMART AND RESILIENT CITIES</b>	<b>928</b>
	<i>ANA STOJANOVIĆ, DEJAN VASOVIĆ</i>	
90.	<b>POTENTIALS OF EPHEMERAL ARCHITECTURE TO ENCOURAGE REUSE AND ADAPTATION OF ABANDONED INDUSTRIAL COMPLEXES</b>	<b>935</b>
	<i>DIMITRA JEZDIMIROVIĆ</i>	
91.	<b>DAMAGE FORMS OF STEEL CONSTRUCTIONS</b>	<b>947</b>
	<i>MARKO MILOŠEVIĆ, DRAGOSLAV STOJIĆ, SRĐAN ŽIVKOVIĆ</i>	
92.	<b>THE USE OF “GEOTEXTILES” FOR THE PROTECTION OF ARCHAEOLOGICAL SITES WITH MOSAICS</b>	<b>959</b>
	<i>ELENA VASIĆ PETROVIĆ</i>	
93.	<b>EVALUATION OF BRIDGE TRAFFIC LOAD MODEL USING B-WIM MEASUREMENTS IN SERBIA</b>	<b>969</b>
	<i>GORAN MILUTINOVIC, RADE HAJDIN</i>	
94.	<b>ANALYSIS OF THE CONCEPT OF BUILDING INTEGRATED PHOTOVOLTAICS WITH INTEGRATION TO THE ARCHITECTURAL DESIGN</b>	<b>979</b>
	<i>VIKTORIJA MANGAROSKA, KOSTA MANGAROSKI</i>	

---

95.	<b><u>THE INTEGRATION OF GREENERY IN ARCHITECTURE AS AN APPROACH TO ROOFTOP EXTENSION</u></b>	<b>991</b>
	<i>IVANA MIŠKELJIN, IGOR MARAŠ</i>	
96.	<b><u>REUSE AND ENVIRONMENTAL IMPACTS OF TREATED DOMESTIC WASTEWATER</u></b>	<b>1002</b>
	<i>MUHAMMED KAMIL ÖDEN, BILGEHAN YABGU HORASAN, CEMALETTIN SARIÇOBAN, ALI ÖZDÖNER</i>	
97.	<b><u>ARCHITECTURAL FORM AND LIBRARY DESIGN</u></b>	<b>1009</b>
	<i>NEVENA PAVLOVIĆ, DANICA STANKOVIĆ</i>	
98.	<b><u>CONTEMPORARY METHODOLOGY OF BANKING DESIGN</u></b>	<b>1020</b>
	<i>ĐURĐINA RANČIĆ, DANICA STANKOVIĆ</i>	
99.	<b><u>STUDIES ON THE IMPACT OF WASTE FOUNDRY SAND ON THE PROPERTIES OF CEMENT COMPOSITES FOR ENVIRONMENT CONCERNS IN OMAN</u></b>	<b>1033</b>
	<i>RATHAN RAJ RAJENDRAN, ALI SAID AHMED MATRAF ALMANJAWI</i>	
100.	<b><u>BULGARIAN PRACTICE AND EXPERIENCE IN DESIGN DEVELOPMENT OF YOUTH CENTRES</u></b>	<b>1044</b>
	<i>BORIANA NOZHAROVA</i>	
101.	<b><u>THE CONSTRUCTION PROJECT EFFICIENCY OF PIER HEAD STRUCTURE DESIGN USING THE HIGH YIELD STRENGTH STEEL</u></b>	<b>1054</b>
	<i>AGUNG FAJARWANTO, ARRY ARYADI, G. AJI SENTOSA, HARRY BUDI PRASETYA, ERI DWI WIBAWA, ANNISA DEWANTI PUTRI, MUHAMMAD ILHAM ADITYA, FARIDZ MOHAMMAD EDRIE</i>	
102.	<b><u>INFLUENCE OF DIFFERENT TYPES OF FIBERS ON PROPERTIES OF CONCRETE</u></b>	<b>1066</b>
	<i>MARKO STOJANOVIĆ, LANA ANTIĆ-ARANĐELOVIĆ, KSENIJA JANKOVIĆ, DRAGAN BOJOVIĆ, ZELJKO FLAJS</i>	
103.	<b><u>DEVELOPING THE DATABASE OF WEFEX NEXUS PROJECTS AND CASE STUDIES</u></b>	<b>1073</b>
	<i>ŽARKO VRANJANAC, STEFANIA MUNARETTO, ALEXANDRA SPYROPOULOU, TAMARA RADENOVIĆ, DEJAN VASOVIĆ, SNEŽANA ŽIVKOVIĆ</i>	
104.	<b><u>INFLUENCE OF THERMAL INSULATION POSITION ON CONDENSATION IN THE WALL</u></b>	<b>1079</b>
	<i>ANKA STARČEV-ČURČIN, VESNA BULATOVIĆ, TIANA MILOVIĆ, MILOŠ ŠEŠLIJA</i>	
105.	<b><u>ENERGY EFFICIENCY OF BUILDINGS IN SERBIA - SOME PERSONAL EXPERIENCES FROM THE PROCESS OF DESIGN AND REALIZATION</u></b>	<b>1087</b>
	<i>ALEKSANDAR RAJČIĆ</i>	
106.	<b><u>ASSESSMENT OF THE QUALITY OF HOUSING STOCK IN BELGRADE ACCORDING TO ENERGY CONSUMPTION</u></b>	<b>1099</b>
	<i>LJILJANA ĐUKANOVIĆ</i>	
107.	<b><u>EFFLUENT QUALITY FROM THE WASTEWATER TREATMENT PLANT LESKOVAC</u></b>	<b>1111</b>
	<i>RASTISLAV TRAJKOVIĆ, MARIJA MILIČEVIĆ, DRAGAN MILIČEVIĆ</i>	
108.	<b><u>RE-VILLAGE ECOLOGICAL EXPERIMENTS IN ARCHITECTURE</u></b>	<b>1121</b>
	<i>ANDREJ JOSIFOVSKI, ANĐELA POSAVEC, STEFAN JANKOVIĆ, JELENA MILOŠEVIĆ</i>	
109.	<b><u>ARCHITECTURE AND TEXTILES - A MILLENNIAL STORY</u></b>	<b>1127</b>
	<i>BEATRICE-GABRIELA JÖGER</i>	
110.	<b><u>SULFATE RESISTANCE OF GEOPOLYMER CONCRETE PRODUCED WITH HAZARDOUS WASTE VITREOUS ENAMEL GENERATED IN THE PRODUCTION PROCESS OF HEATING DEVICES</u></b>	<b>1139</b>
	<i>NENAD RISTIĆ, JELENA BIJELIĆ, DUŠAN GRDIĆ, GORDANA TOPLIČIĆ-ČURČIĆ, ZORAN GRDIĆ</i>	
111.	<b><u>SIGNIFICANCE OF NUMERICAL SIMULATION OF SOIL MEDIA IN SSI ANALYSIS OF FRAMES</u></b>	<b>1147</b>
	<i>KEMAL EDIP, VLATKO SHESHOV, JULIJANA BOJADJIEVA, TONI KITANOVSKI AND DEJAN IVANOVSKI</i>	
112.	<b><u>LANDSLIDE SUSCEPTIBILITY MAPS (LSM) - METHODOLOGY AND APPLICATION IN SPATIAL PLANNING</u></b>	<b>1154</b>
	<i>ADNAN IBRAHIMOVIĆ, KENAN MANDŽIĆ, NEDRETA KIKANOVIĆ, ELVIR BABAJIĆ</i>	
113.	<b><u>APPLICATION OF GIS IN A SYSTEM FOR PLANNING, MANAGEMENT, AND MAINTENANCE OF SEWER NETWORK</u></b>	<b>1166</b>
	<i>NEDRETA KIKANOVIĆ, ELVIR FERHATBEGOVIĆ</i>	
114.	<b><u>THE IMPORTANCE OF THE NEXUS GOVERNANCE FOR ACHIEVING SDGS</u></b>	<b>1178</b>
	<i>TAMARA RAĐENOVIĆ, DEJAN VASOVIĆ, ŽARKO VRANJANAC, SNEŽANA ŽIVKOVIĆ, SLOBODAN MILUTINOVIĆ</i>	

# CLASSIFICATION OF RAILWAY SUPERSTRUCTURE RECONSTRUCTION METHODS

Jelena Dimitrijević<sup>1</sup>, Zlatko Zafirovski<sup>2</sup>

## Abstract

*The concept of railway reconstruction represents a form of corrective maintenance when regular continuous maintenance cannot restore the railway to a functional condition. Renovation is most often focused on the elements of superstructure such as ballast, sleepers, fastening system and rails. In the circumstance that the substructure additionally has to be repaired, all related operations are transformed into preparatory operations and take precedence over all procedures involving the restoration of the superstructure. The chosen method of construction has a direct impact on the quality of construction and the efficiency of operations. The required quality is directly related to the category of railway being built, with higher requirements as the railway ranks higher and has higher projected speed. Aside from the required quality and efficiency of construction, the chosen method is also influenced by the available space for maneuvering the machinery. The paper provides a basic classification of methods for restoring railway superstructures, with specific references to the positive and negative aspects of each method.*

**Key words:** *railway superstructure, railway reconstruction, railway's superstructure mechanized renewal*

---

<sup>1</sup>Teaching Assistant, M.Sc., PhD student, University of Niš, Faculty of Civil Engineering and Architecture, Serbia, [jelena.dimitrijevic@gaf.ni.ac.rs](mailto:jelena.dimitrijevic@gaf.ni.ac.rs)

<sup>2</sup>Associate professor, PhD, University Ss. Cyril and Methodius, Faculty of Civil Engineering – Skopje, Republic of North Macedonia, [zafirovski@gf.ukim.edu.mk](mailto:zafirovski@gf.ukim.edu.mk)

## 1. INTRODUCTION

Railway superstructures form the vital infrastructure that enables safe and efficient rail operations. The elements of superstructure, including ballast, sleepers, fastening systems and rails, are subjected to constant stresses and strains due to heavy traffic loads, adverse weather conditions and the natural wear and tear of daily operations. Over time, these factors can lead to the deterioration of railway superstructure, compromising their integrity and functionality. To ensure the continuous and reliable operation of railways, regular maintenance and repair efforts are undertaken. However, in some cases, the extent of damage or deterioration may exceed the capabilities of regular maintenance procedures. Railway reconstruction represents a form of corrective maintenance employed when regular continuous maintenance fails to restore the railway to a functional condition.

In this paper, a comprehensive analysis and classification of methods employed for maintaining and restoring railway superstructures is provided, considering the positive and negative aspects associated with each method. Certain methods are equally used for regular and corrective maintenance. Therefore, this classification will include all measures, both for maintenance and track correction, which return the track to a usable state in accordance with the relevant regulations [1].

Traditional manual methods, mechanized renewal techniques and advanced technologies such as automated track construction systems are analyzed based on their positive aspects, including improved construction speed, enhanced quality control and reduced labor intensity. The negative aspects, such as high capital investment, particular workforce requirements and potential limitations in certain terrains or constrained work areas, are also discussed [2].

The selection of an appropriate construction method directly influences the construction quality and operational efficiency. It is influenced by various factors. The category of railway being built plays a crucial role in determining the required quality standards. Higher-ranking railways and those designed for higher speeds demand more stringent quality requirements to ensure safe and efficient operations [3]. Furthermore, the method selection is influenced by the available space for maneuvering construction machinery. Factors such as track geometry, alignment, track stiffness and ride comfort are considered during the decision-making process.

Improving an existing track requires predicting the likely rate of track deterioration as a function of variables related to the train and its periodicity. So far, there are currently no track deterioration methodologies available to examine the condition of a railway track [4].

The findings of this paper provide valuable insights for railway authorities, engineers and researchers involved in railway reconstruction projects. The classification of methods, along with the evaluation of their positive and negative aspects, will facilitate informed decision-making and contribute to the successful restoration of railway superstructures. Ultimately, this study should direct to appropriate model development for scheduling and planning maintenance work, as well as emerging research trends and potential holes in the corresponding decision-making models [5].

## 2. CLASSIFICATION OF METHODS

The appropriate methods for railway superstructure restoration are categorized into three main groups: traditional manual methods, mechanized renewal techniques and advanced technologies. Each method offers distinct advantages and considerations related to construction speed, quality control, labor efficiency and capital investment [2, 6].

Table 1. Method presentation according to purpose of application

	Method	Resources	Maintenance	Renewal
1	Traditional manual methods	Skilled workforce	x	
		Hand tool		
		Easy machinery		
2	Mechanized renewal techniques	Skilled workforce	x	x
		Qualified machinists		
		Machinery		
		Heavy machinery		
3	Automated track construction systems	Qualified machinists		x
		One machine chain (Removing old and installing new superstructure elements)		
		One machine chain (installing new superstructure elements)		

### 2.1. Traditional Manual Method

Traditional manual methods involve manual labor and conventional construction techniques. These methods typically require a skilled workforce to carry out tasks such as track removal, ballast replenishment, sleeper replacement and rail installation. Traditional methods have been widely used in railway reconstruction projects for many years and offer several advantages. They are generally adaptable to various terrains and work areas, making them suitable for projects with limited access or complex site conditions. These methods also provide flexibility in adjusting construction processes based on on-site conditions and challenges. The tasks can be done quickly and easily, with no need for interrupting traffic. No additional preparation or procedure is required. They are appropriate for sudden and dangerous situations where immediate intervention is required. Hand tools and small machinery are typically used for this type of work.

However, traditional manual methods can be labor-intensive and time-consuming compared to mechanized or automated approaches. They may require a larger workforce and longer construction durations, which can impact project timelines and costs. Quality control may also be more challenging with manual methods, as they rely heavily on the skills and experience of the construction workers. Additionally,

these methods may have limitations in terms of achieving high construction speeds and maintaining consistent quality across large-scale projects.

## 2.2. Mechanized Renewal Techniques

Mechanized renewal techniques utilize specialized machinery and equipment to carry out various tasks involved in railway superstructure restoration. These procedures aim to improve construction speed, quality control and labor efficiency [7]. Mechanized techniques can include the use of track-laying machines (cranes), ballast cleaner, rail grinder, mechanized ballast tampers, wagon plateaus, rail threader, track stabilization machine, bulldozers and automated rail welding systems, among others.

Although certain procedures, such as re-ballasting and rail re-profiling, are classified as maintenance operations, they improve track performance and lead to improved quality of ride, fewer track defects and greater train stability. These methods also contribute to enhanced safety by minimizing the risk of derailments and track failures. Despite just being partially completed, this renovation is very significant overall. Superstructure assistances, such as re-ballasting, sleeper replacement, rail re-profiling and fastening system upgrades, both maintenance and renovation methods are discussed, highlighting their contributions to improved track stability, load-bearing capacity and ride quality.

Re-ballasting is a common and often used procedure in superstructure renovation. The very brief lifecycle of the ballast layer is a contributing factor in the ballast track's comparatively high maintenance expenses. It has been demonstrated that the technology of the machinery used to carry out the procedure has a significant impact on the efficiency and durability of ballasting (vertical and side tamping method) [8]. Re-ballasting involves the removal of old and worn-out ballast and the replacement with fresh ballast material. This process helps to restore the track's stability by providing a solid foundation for the sleepers and rails. It also assists in maintaining proper drainage and reducing track settlement issues [9]. Re-ballasting enhances the load-bearing capacity of the track, allowing it to support heavy train traffic and reduce the risk of track failures. This procedure is more appropriate for routine maintenance, but considering how much it improves the condition of the superstructure, it is comparable to the quality reached when installing new track.

Rail re-profiling is another represented technique employed in superstructure correction. It is simultaneous maintenance and renovation process. Continuous train traffic can cause wear and deformation on the rail profiles, leading to irregularities and an uneven track surface. Rail re-profiling involves the removal of excessive metal from the rail's running surface, restoring the desired profile. This procedure improves ride quality, reduce track noise and maintain proper wheel-rail contact, thereby enhancing safety and comfort for train operations. The technology of re-profiling is the focus of current research in this maintenance measure [10]. Rail re-profiling machines are utilized for such purposes. The benefit of preventive against remedial re-profiling is really significant [11].

One of the most important repairing activities of superstructure is the replacement of sleepers when fields or sections are replaced. Such procedures require appropriate substrate preparation and nearly every rail replacement. Sleepers, provide support and stability to the rails. Over time, sleepers may deteriorate due to decay, insect infestation or mechanical damage. In the renovation process,

damaged sleepers are replaced with new ones to ensure a reliable and sturdy track structure. Mechanized sleeper replacement includes replacing smaller fields or continuously replacing on the area where the reconstruction is planned. Cranes are used for setting sleeper fields using either the ready-made fields approach (Figures 2) or the continuous method (Figure 1) [2, 12]. In the case of a lack of space, alternate methods for laying ready-made fields, including the one shown in Figure 3, can be used.



Figure 1. Removal of new sleepers from wagon plateau to intended position, using gantry crane (continuous method)



Figure 2. An example of ready-made field's method for sleepers setting down [13]



*Figure 3. An example of ready-made field's method when it is impossible to utilize a crane due to a lack of space*

Upgrading the fastening systems is also a critical aspect of superstructure renovation. Fastening systems, such as clips, bolts, and plates, secure the rail to the sleepers and ensure proper alignment. Over time, these components may become worn or damaged, compromising the stability of the track. Upgrading the fastening systems involves replacing worn-out components with new, more robust ones. This process helps to maintain proper rail alignment, reduce track maintenance requirements and enhance the overall track performance.

Work on the installation of new switches should be classified as a special type of work during the superstructure renovation. These operations can be done as part of routine maintenance, independently of the rest of the track, or as part of the reconstruction of a specific segment. Switches could be transported and installed in sections or as a single unit, depending on the available machinery and transportation conditions [6].

Mechanized renewal techniques offer significant advantages in terms of increased construction speed and productivity. The use of specialized machinery enables faster track laying, ballast compaction and rail installation. These methods also provide improved precision and quality control, resulting in more consistent track geometry, alignment and stability. Mechanized techniques can reduce labor intensity and minimize the reliance on manual labor, thereby optimizing workforce utilization and potentially reducing construction costs.

However, it is important to consider certain challenges associated with superstructure renovation. Specialized equipment and machinery are often required to carry out these tasks effectively. Skilled labor and expertise are necessary for the precise execution of renovation techniques. Additionally, construction activities during superstructure renovation may cause temporary disruptions to train operations, necessitating careful scheduling and coordination to minimize inconvenience to rail users.



Mechanized renewal techniques may require substantial capital investment in acquiring and maintaining specialized equipment. Skilled operators and maintenance personnel are necessary to operate and manage the machinery effectively. Additionally, certain terrains or constrained work areas may pose limitations on the use of large-scale mechanized equipment. Proper planning and evaluation of site conditions are crucial to determine the feasibility and efficiency of mechanized renewal techniques.

### **2.3. Advanced Technologies**

Advanced technologies, such as automated track construction systems, represent the cutting-edge approaches in railway superstructure restoration. These systems incorporate advanced robotics, computer-controlled processes and artificial intelligence to automate various construction tasks. Automated track construction systems include one part construction technology [6].

This is entirely related to the reconstruction procedure. Automatic track construction systems can be used in two different ways. In the first instance, it is a composition that removes and replaces the old superstructure components in a single pass. The second scenario only involves the process of arranging new parts on a previously created substrate. The lone exception is track stabilization, which includes a time delay between installation and full track stabilization [2].

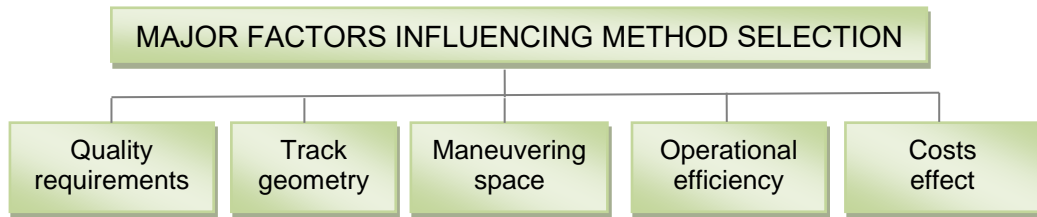
The use of advanced technologies offers significant advantages in terms of construction speed, precision and quality control. Automated systems can achieve high construction speeds while maintaining accuracy and consistency in track geometry, alignment and other critical parameters. These technologies reduce the reliance on manual labor, leading to improved workforce efficiency and reduced construction time. They also provide enhanced quality control through real-time monitoring and adjustments during the construction process.

However, advanced technologies come with higher capital investment costs and may require specialized expertise for operation and maintenance. The implementation of automated track construction systems may be more suitable for large-scale projects with well-defined track requirements and consistent work areas. Certain terrains or constrained work areas may pose challenges for the deployment and maneuverability of robotic or automated systems, necessitating careful evaluation of site conditions and project specifications.

## **3. METHOD SELECTION**

The selection of an appropriate construction method for railway reconstruction is a critical decision that significantly influences the quality of construction and the operational efficiency of the railway. The chosen method must align with the specific requirements and considerations associated with the project, ensuring that the reconstructed railway meets the desired standards and operates safely and efficiently [7].

In Figure 4. major factors influencing method selection are presented.



*Figure 4. major factors influencing method selection*

Quality considerations play a fundamental role in the method selection process. The category of railway being built is a primary factor that determines the required quality standards. Railways with higher rankings, such as high-speed or mainline railways, demand more stringent quality requirements compared to lower-ranking or branch line railways. Higher-ranking railways often have stricter tolerances for track geometry, alignment, and track stiffness to ensure safe and reliable operations at increased speeds. The selection of a method must take into account these quality standards to meet the specific needs of the railway being reconstructed.

Track geometry, which includes parameters such as gauge, alignment and curvature, has a significant impact on the method chosen for reconstruction. Different methods may be more suitable for specific track geometries, ensuring accurate alignment and geometry control during construction. Considerations for ride comfort, such as minimizing track irregularities and ensuring smooth transitions between track sections, are also important factors that influence the method selection process.

The availability of space for maneuvering construction machinery is another crucial consideration in method selection. The chosen method must be feasible and efficient within the given work area. Space constraints can limit the use of certain construction techniques, such as large-scale mechanized or automated methods. In such cases, alternative methods that can accommodate the available space while maintaining construction quality and efficiency need to be considered.

The efficiency of the selected construction method is crucial for timely completion and cost-effectiveness of the reconstruction project. Methods that offer faster construction speeds, enhanced quality control and reduced labor intensity can contribute to improved operational efficiency. Mechanized or automated methods, such as track-laying machines or automated track construction systems, can significantly accelerate construction processes and reduce reliance on manual labor.

However, it is important to note that the selection of certain advanced or mechanized methods may require specialized equipment, skilled workforce, and higher capital investment. These factors need to be considered during the decision-making process, weighing the potential benefits against the associated costs and resource requirements [14].

## 4. CONCLUSION

By examining traditional manual methods, mechanized renewal techniques, and automated track construction systems, this paper has provided valuable insights into the advantages and considerations associated with each method.

The comprehensive analysis and classification of methods for restoring railway superstructures presented in this paper serve as a valuable resource for practitioners and researchers involved in railway reconstruction projects. By leveraging this knowledge, stakeholders can make informed decisions, enhance the quality and efficiency of railway reconstruction, and contribute to the safe and reliable operation of railway systems.

In summary, the selection of an appropriate construction method for railway reconstruction involves, among others, careful consideration of quality requirements, track geometry, efficiency, cost-effectiveness and the availability of space for maneuvering machinery. By aligning the chosen method with these considerations, railway authorities and engineers can ensure that the reconstructed railway meets the desired quality standards while maximizing operational efficiency.

Due to the complexity of decision-making when determining a technique and taking into consideration relevant factors in decision-making, it would be beneficial in the future to focus on the development of decision-making models. The process of degradation of the superstructure might be predicted by continually monitoring the track condition parameters. As a result, the on-going interventions on the track mandated by the regulations, would be replaced with meaningful regular and corrective maintenance specific to the railway in question and its superstructure elements.

## REFERENCES

- [1] **Pravilnik o održavanju gornjeg i donjeg stroja železničkih pruga**, *Službeni glasnik Republike Srbije*, br.39/2023
- [2] Tomičić-Torlaković Mirjana: **Održavanje železničkih pruga**. *Građevinski fakultet*, Beograd, 1998.
- [3] Týfa Lukás, Kruntorád Jan, Tomaschko Ondřej: **Railway superstrucute for high-speed rails**. *Acta Polytechnica CTU proceedings*, Vol.31, pp.53-57, 2021.
- [4] de Melo Andre L.O., Kaewunruen Sakdirat, Papaelias Mayorkinos, Bernucci Liedi L.B., Motta Rosangela: **Methods to monitor and evaluate the deterioration of track and its components in a railway in-services : A systematic review**. *Frontiers in Built Environment*, Vol.6, No.118, 2020.
- [5] Sedghi Mahdieh, Kauppila Osmo, Bergquist Bjarne, Vanhatalo Erik, Kulahci Murat: **A taxonomy of railway track maintenance planning and scheduling: A review and research trends**. *Reliability Engineering and System Safety*, Vol.215, No.107827, 2021
- [6] Fisher Szabolcs, Eller Balázs, Kada Zoltán, Németh Attila: **Railway construction**. *UNIVERSITAS-GYŐR NONPROFIT KFT, GYŐR*, 2015.
- [7] Ilinykh Andrey S., Kolyasov Konstantin M., Yaitskov Ivan A.: **Assessing the effectiveness of track operation mechanization facilities**. *Transportation Research Procedia*, Vol.61, pp.668-673, 2022.
- [8] Przybyłowicz Michal, Sysyn Mykola, Gerber Ulf, Kovalchuk Vitalii, Fischer Szbolcs: **Comparison of the effects and efficiency of vertical and side tamping methods for ballasted railway tracks**. *Construction and Building Materials*, Vol.314, No.125708, 2022.
- [9] Paiva Cassio, Ferreira Mateus, Ferreira Adelino: **Ballast drainage in Brazilian railway infrastructures**, *Construction and Building Materials*, Vol.92, pp.58-63, 2015.

- [10] Binoj Joseph Selvi, Shah Vijesh Yogesh, Chhatwani Bhavna, Chhikara Rahul: **Influence of grinding on rail surface and profile- A review**. *Materials Today: Proceedings*, IN PRESS
- [11] Popović Zdenka, Mičić Milica, Lazarević Luka: **Guidelines for rail reprofiling**. *Transportation Research Procedia*, Vol.63, pp.2562-2570, 2022.
- [12] Dimitrijević Jelena, Zafirovski Zlatko, Matejević-Nikolić Biljana, Milijić Marko: **Application of the continuous method with gantry crane on railway reconstruction**: *Proceedings of the XXI International Scientific Conference on Construction and Architecture VSU'2021, Sofia*, Vol.II, pp. 425-430, 2021.
- [13] <https://www.youtube.com/watch?v=6OkHQ0CTj7g> ,(18.11.2019.)
- [14] Sresakoolchai Jessada, Kaewunruen Sakdirat: **Railway infrastructure maintenance efficiency improvement using deep reinforcement learning integrated with digital twin based on track geometry and component defects**. *Scientific Reports*, Vol.13, No.2439, 2023.

## COMPARISON OF DAILY AND MONTHLY REFERENCE EVAPOTRANSPIRATION IN AN URBAN AREA

Mladen Milanovic<sup>1</sup>, Slavisa Trajkovic<sup>2</sup>, Milan Gocic<sup>3</sup>, Martina Zelenakova<sup>4</sup>, Hany F. Abd-Elhamid<sup>5</sup>

### Abstract

*Evapotranspiration is one of the most important components of the hydrological circle due to the direct interdependence between soil, plants and the atmosphere, i.e. it represents the critical factor for local and regional planning of water quantity and quality. The presented analysis of daily and monthly reference evapotranspiration ( $ET_0$ ) was used to define the most accurate approach in urban areas. Two approaches are applied in order to estimate, more precisely, evapotranspiration for the development of urban green areas with a very heterogeneous urban environment. The first approach is based on the calculated daily  $ET_0$  values which are converted into daily average  $ET_0$  values on a monthly level, while the second approach is based on the  $ET_0$  directly calculated from the average daily data on a monthly level. Meteorological data used for analysis were collected from an automatic meteorological station in the urban area of Nis from 15<sup>th</sup> July 2022 to 28<sup>th</sup> February 2023. The  $ET_0$  values were determined using the Penman-Monteith method. To compare the proposed two approaches, the following three statistical tests were used: root mean square error (RMSE), mean bias error (MBE) and mean absolute error (MAE). The results of the statistical tests showed that there is no significant difference between the approaches, i.e. that the results are almost the same (RMSE = 0.056, MBE = -0.026 and MAE = 0.035). The difference between the approaches varies from 0.6 % to 3 %, depending on the observed month.*

**Key words:** reference evapotranspiration, automatic meteorological station, urban area

---

<sup>1</sup> MSc, Teaching Assistant, Faculty of Civil Engineering and Architecture, mmsmladen@gmail.com

<sup>2</sup> PhD, Professor, Faculty of Civil Engineering and Architecture, slavisa@gaf.ni.ac.rs

<sup>3</sup> PhD, Associate Professor, Faculty of Civil Engineering and Architecture, milan.gocic@gaf.ni.ac.rs

<sup>4</sup> PhD, Professor, Department of Environmental Engineering, Faculty of Civil Engineering, Technical University of Kosice, martina.zelenakova@tuke.sk

<sup>5</sup> PhD, Professor, Department of Environmental Engineering, Faculty of Civil Engineering, Technical University of Kosice, hany\_farhat2003@yahoo.com

## 1. INTRODUCTION

The estimation of evapotranspiration (ET) presents a significant challenge for both researchers and operational hydrologists. A reliable estimation of ET is essential for urban hydrology, especially for water balance, water supply, water quality, groundwater level and urban floods [1]. The main problem is to define the most accurate method for ET estimation in specific urban conditions. There are several approaches which directly measure evapotranspiration, such as lysimeter and soil water balance (hydrological methods), eddy covariance and Bowen ratio energy balance (micrometeorological methods) as well as chamber systems and sap flow measurement (plant physiological methods) [2]. In addition, the remote sensing approach can be used for ET estimation. All the mentioned approaches are relatively complex requiring experts from different fields, time-consuming and expensive [3-5].

There are numerous methods for defining reference evapotranspiration ( $ET_0$ ) using an empirical approach. The International Commission for Irrigation and Drainage and the Food and Agriculture Organization of the United Nations recommended the FAO56 Penman-Monteith method as the most appropriate and standard model for computing  $ET_0$ . The method incorporates energy balance and aerodynamic theory and is based on meteorological data. In order to provide the reliable urban data for this method, automatic weather stations (AWS) are utilized. The AWS provides reliable data by using sophisticated technology and modern measurement techniques. This kind of station allows work without the supervision of an observer, reduction of human errors, as well as measurement and reports with high frequency [6].

Daily  $ET_0$  values are important because they are the starting point for irrigation planning methods. They can later be modified according to the crop grown, its growth stage and the soil water content, especially in arid environments. Monthly and yearly  $ET_0$  data are useful for regional crop management, water use assessment and water management [7].

The Penman-Monteith method, the reference method for  $ET_0$  calculation, is a nonlinear method, so there are differences between different approaches in  $ET_0$  estimation. There is no linearity in algorithms used for meteorological data calculation, such as vapour pressure and the slope of the saturation vapour pressure curve [8]. For these reasons, the  $ET_0$  values obtained using various time steps can be different.

There are several studies where the authors compared  $ET_0$  values based on different approaches (time scales) [4, 9-13]. Bakhtiari et al., 2017 [4], analyzed daily and hourly  $ET_0$  values, obtained with the Penman-Monteith equation. Daily  $ET_0$  values were calculated by adding hourly  $ET_0$  values and compared with directly computed daily values of  $ET_0$ . The final results show that there is a distinctive difference between the analyzed approaches. A direct computed  $ET_0$  was greater than the sum of hourly  $ET_0$ . The same comparative principle was conducted for northeastern Austria [9]. The overall result showed that approaches are well correlated and have an obvious seasonal effect. The closest results were during the summer months. The same results were obtained for the Harran plain in Turkey [10].

In order to evaluate the general relationships between different time scales for  $ET_0$ , daily and monthly  $ET_0$  were estimated using the Penman, Penman-Monteith and Hargreaves equations [11]. Statistical analysis showed a significant difference

between the three methods, while the mean difference between Penman-Monteith and Hargreaves equation was 1 mm annually. The maximum and minimum values belonged to Hargreaves and Penman-Monteith equations, respectively.

The paper presents a comparative analysis of two approaches for the calculation of daily average reference evapotranspiration on a monthly level in an urban area, i.e. 1) the calculation of daily  $ET_0$ , converted into the daily average  $ET_0$  values on a monthly level and 2) calculation of average daily data on a monthly level, after which  $ET_0$  was calculated.

## 2. METHODOLOGY

### 2.1. Study Area and Data

The study area is the territory of the urban area in Nis. Nis is located in South-eastern Serbia and has a humid subtropical climate with continental influences. The average annual temperature is 11.9 °C and annual precipitation is 607 mm. The warmest month is July (23.1 °C), while the coldest one is January (0.9 °C). The sunniest month is August, with an average of 277 hours of sunshine. June is the wettest month (88 mm of precipitation), while the driest month is February with 40 mm of precipitation.

The data used in this study are collected from the automatic weather station located in an urban area of Nis, with coordinates 43°19' N, 21°56' E and elevation of 197.2 m a.s.l. The analyzed period was based on the daily data from 15<sup>th</sup> July 2022 to 28<sup>th</sup> February 2023. AWS is equipped with sensors for measurement: air temperature and relative humidity (HC2S3-L Temperature and Relative Humidity Probe, Campbell scientific), wind speed and direction (05103-5 Wind Monitor RM Young, Campbell scientific) and solar radiation (CS300-L Pyranometer, Campbell scientific). The data from sensors are gathered at 5-minute interval, using the datalogger CR1000 (CR1000 Measurement and Control Datalogger, Campbell scientific).

### 2.2. Penman monteith reference evapotranspiration method

Daily reference evapotranspiration was calculated using the Penman-Monteith method [14]:

$$ET_0 = \frac{0.408\Delta(R_n - G) + \gamma \frac{900}{T + 273} u_2 (e_s - e_a)}{\Delta + \gamma(1 + 0.34u_2)} \quad (1)$$

Where:

$R_n$  – net radiation at the crop surface [ $MJ m^{-2} day^{-1}$ ]

$G$  – soil heat flux density [ $MJ m^{-2} day^{-1}$ ]

$T$  – air temperature at 2 m height [ $^{\circ}C$ ]

$u_2$  – wind speed at 2 m height [ $m s^{-1}$ ]

$e_s$  – saturation vapour pressure [kPa]

$e_a$  – actual vapour pressure [kPa]

$e_s - e_a$  – saturation vapour pressure deficit [kPa]

$\Delta$  – slope vapour pressure curve [ $kPa ^{\circ}C^{-1}$ ]

$\gamma$  – psychrometric constant [ $kPa ^{\circ}C^{-1}$ ]

Two approaches were used for this study. Firstly, daily  $ET_0$  was calculated based on the meteorological parameters, and then converted into daily average  $ET_0$  values on a monthly level ( $ET_{0,d\text{ avg}}$ ). Secondly, average daily meteorological parameters were calculated for each month, and the daily average  $ET_0$  values were then calculated for each month ( $ET_{0,d}$ ) based on the mentioned values.

### 2.3. Evaluation criteria

Three statistical tests (root mean square error – RMSE, mean bias error – MBE and mean absolute error - MAE) were used for result comparison:

$$RMSE = \sqrt{\frac{1}{n} \sum_{i=1}^n (ET_{0,d\text{ avg}} - ET_{0,d})^2} \quad (2)$$

$$MBE = \frac{1}{n} \sum_{i=1}^n (ET_{0,d\text{ avg}} - ET_{0,d}) \quad (3)$$

$$MAE = \frac{1}{n} \sum_{i=1}^n |ET_{0,d\text{ avg}} - ET_{0,d}| \quad (4)$$

where  $n$  is the total number of months,  $ET_{0,d\text{ avg}}$  is the average daily reference evapotranspiration on a monthly level and  $ET_{0,d}$  is the daily reference evapotranspiration directly calculated from the average daily data on a monthly level. Ideally, the best match for all the three tests is value 0.

## 3. RESULTS AND DISCUSSION

The analysis of urban  $ET_0$  in Nis shows that plant water demands are the greatest in July and August, with the maximum value of 5.1 mm/day, Figure 1. The lowest values of  $ET_0$  are in December (0.3 mm/day). According to Figure 1, the months of August and September exhibit large oscillations between daily  $ET_0$  values, unlike the  $ET_0$  values for other months.

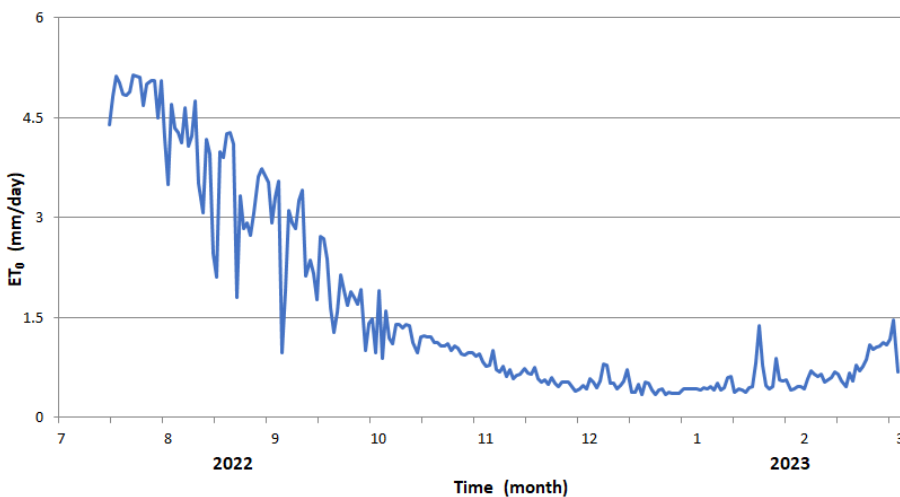


Figure 1. Daily reference evapotranspiration for an urban area in Nis

Figure 2 shows the differences/similarities between the two approaches in the calculation of daily  $ET_0$  values. It is obvious that the differences come to light in July



(2.8 %), at the beginning of the analyzed period, where  $ET_{0,d}$  have a slightly higher value than  $ET_{0,d,avg}$ . Also, there are differences between the values in January and February, i.e. 2.5 % and 2.9 %, respectively. There are no significant differences between the approaches for other months, it is 0.6 % for September.

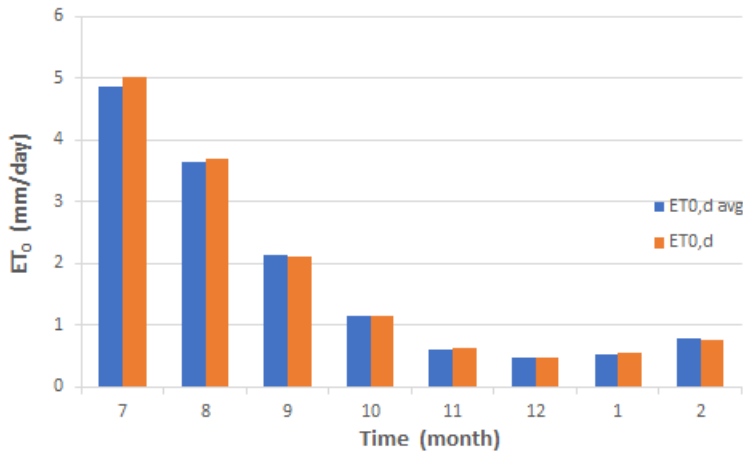


Figure 2. Daily average  $ET_0$  on a monthly level, calculated based on two approaches

The relationship between the two approaches from 15<sup>th</sup> July 2022 to 28<sup>th</sup> February 2023 is shown in Figure 3. The regression equation between  $ET_{0,d,avg}$  and  $ET_{0,d}$  is  $ET_{0,d,avg} = 1.0276 ET_{0,d} - 0.0229$  with a determination coefficient of 99.98 %, which is significantly high.

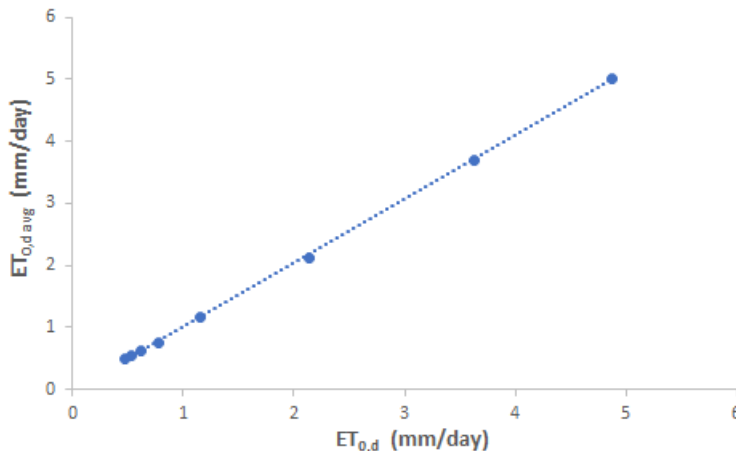


Figure 3. Relationship between the two approaches

The analysis of statistical tests shows great similarities (almost perfect matching) between  $ET_{0,d,avg}$  and  $ET_{0,d}$  for the entire observed period, i.e. RMSE = 0.056, MBE = - 0.026 and MAE = 0.035.

#### 4. CONCLUSION

The analysis of the Penman-Monteith method was conducted based on two approaches ( $ET_{0,d,avg}$  and  $ET_{0,d}$ ), in an urban area of Nis for the period from 15<sup>th</sup> July 2022 to 28<sup>th</sup> February 2023. The results show that there are no significant differences between the proposed approaches (maximum 2.9 % and minimum 0.6 %). Three

statistical tests showed the same results, i.e. almost ideal matching (RMSE = 0.056, MBE = - 0.026 and MAE = 0.035)., Considering the non-linearity of the Penman-Monteith equation, it can be concluded that both approaches are adequate for reference evapotranspiration calculation for the previously defined urban conditions.

Further study will be oriented towards the analysis of hourly and daily  $ET_0$  in different locations in urban areas. In addition to the Penman-Monteith method, other methods, such as Hargreaves and Thornthwaite methods, will be included in the calculation procedure for urban conditions.

## ACKNOWLEDGMENTS

This research was funded by the Ministry of Education, Science and Technological Development of the Republic of Serbia, grant number 451-03-47/2023-01/200095 as well as part of the bilateral scientific project between Serbia and Slovakia, grant numbers APVV-20-0281 and SK-SRB-21-0052.

## REFERENCES

- [1] Grimmond C.S.B., Oke T.R.: **Evapotranspiration rates in urban areas**. Proceedings of IUGG 99, Symposium HSS, Birmingham, 235-243, 1999.
- [2] Nouri Hamideh, Beecham Simon, Kazemi Fatemeh, Hassanli Ali Morad: **A review of ET measurement techniques for estimating the water requirements of urban landscape vegetation**. Urban Water Journal, Vol. 10, No. 4, 247-259, 2013.
- [3] Irmak S., Irmak A., Allen R.G., Jones J.W.: **Solar and net radiation-based equations to estimate reference evapotranspiration in humid climates**. Journal of irrigation and drainage engineering, Vol. 129, No. 5, 336-347, 2003.
- [4] Bakhtiari Bahram, Khanjani Mohamad Javad, Fadaei-Kermani Ehsan: **Differentiation of computed sum of hourly and daily reference evapotranspiration in a semi-arid climate**. Journal of applied research in water and wastewater, Vol. 8, 358-362, 2017.
- [5] Perera Kushan, Western Andrew, Nawarathna Bandara, George Biju: **Comparison of hourly and daily reference crop evapotranspiration equations across seasons and climate zones in Australia**. Agricultural water management, Vol. 148, 84-96, 2015.
- [6] World Meteorological Organization: **International meteorological vocabulary, second edition**, No. 182, Geneva, 1992.
- [7] Zhang Xiaotao, Kang Shaozhong, Zhang Lu, Liu Junqi: **Spatial variation of climatology monthly crop reference evapotranspiration and sensitivity coefficients in Shiyang river basin of northwest China**. Agricultural water management, Vol. 97, 1506-1516, 2010.
- [8] Trajkovic Slavisa: **Testing hourly reference evapotranspiration approaches using lysimeter measurements in a semiarid climate**. Hydrology research, Vol. 41, No. 1, 38-49, 2010.
- [9] Nolz Reinhard, Rodny Marek: **Evaluation and validation of the ASCE standardized reference evapotranspiration equations for subhumid site in northeastern Austria**. Journal of hydrology and hydromechanics, Vol. 67, No. 3, 289-296, 2019.
- [10] Yildirim Ersoy, Cakmak Belgin, Kose Tamer: **Comparison of hourly and daily reference evapotranspiration values of GAP project area**. Journal of applied sciences, Vol. 4, No. 1, 53-57, 2004.

- [11] Saghravani Seyed Reza, Mustapha Sa'ari, Ibrahim Shahrin, Randjbaran Elias: **Comparison of daily and monthly results of three evapotranspiration models in tropical zone: a case study**. American journal of environmental sciences, Vol.5, No. 6, 698-705, 2009.
- [12] Koffi Djaman, Koudahe K., Lombard K., O'Neill M.: **Sum oh hourly vs. daily Penman-Monteith grass-reference evapotranspiration under semiarid and arid climate**. Irrigation & drainage systems engineering, Vol. 7, No. 1, 1-6, 2018.
- [13] dos Santos Aline Aparecida, de Souza Jorge Luiz Moretti, Rosa Stefanie Lais Kreutz: **Hourly and daily reference evapotranspiration with ASCE-PM model for Parana state, Brazil**. Revista brasileira de meteorologia, Vol. 36, 1-13, 2021.
- [14] Allen Richard, Pereira Luis, Raes Dirk, Smith Martin: **Crop evapotranspiration (guidelines for computing crop water requirements)**. *FAO Irrigation and drainage Paper, No. 56.*, Rome, 1998.

# EARTHQUAKE RESISTANCE OF PILE FOUNDATIONS

**Borko Miladinovic<sup>1</sup>, Zvonko Tomanovic<sup>2</sup>**

## **Abstract**

*Seismic standard Eurocode 8 in its 5<sup>th</sup> part treats the seismic resistance of pile foundations in a quite limited and insufficient scope for practical application. Only some general rules and recommendations are given. The generally known division of the lateral seismic load of piles into kinematic and inertial components is defined. However, it is not described how to determine these components and how the pile internal forces and deflections of these components can be superimposed. The necessity of conducting an analysis of the interaction among foundation soil, piles and superstructure during an earthquake was recognised in order to define the seismic resistance of pile foundations. However, only a few general recommendations are given regarding this very complicated interaction. Finally, the standard Eurocode 8 recognizes the design situation that is very common in civil engineering practice. This is a situation when it is impossible to avoid the appearance of a plastic hinge on the pile during an earthquake, most often at its upper end i.e. at the place where the pile is fixed into a pile cap. However, the standard Eurocode 8 does not treat this participation of piles in the process of seismic energy dissipation. Due to the importance of this topic, especially in Montenegro, in this paper the previously mentioned aspects of seismic resistance of pile foundations, which the standard Eurocode 8 practically only "recognizes", will be analysed in more detail. The analyses will be conducted based on the results of the research that the authors of this paper conducted in the previous period, the available research results of other researchers, as well as the rules and recommendations of several seismic standards. The main goal of the paper is to help engineers in practice to overcome the previously mentioned shortcomings of the standard Eurocode 8.*

**Key words:** *Earthquake, Pile Foundations, Seismic Soil-Pile-Structure Interaction*

---

<sup>1</sup> MSc, Teaching Associate, University of Montenegro, Faculty of Civil Engineering, borkom@ucg.ac.me

<sup>2</sup> PhD, Professor, University of Montenegro, Faculty of Civil Engineering, zvonko@t-com.me

## 1. INTRODUCTION

Experiences in past earthquakes have shown that the main reason for the complete collapse of structures can be the insufficient seismic resistance of their pile foundations. As a dramatic example, the collapse of the Showa Bridge during the 1964 Niigata earthquake (Fig. 1a) can be mentioned. The superstructure (bridge deck) could not "withstand" the large lateral movements of the piers (about 1m), which actually only "followed" the large lateral movements of the piles on which they were founded. Also, errors in the way of analysing the interaction of the superstructure with the pile foundation and foundation soil during an earthquake (hereinafter seismic SPS interaction) might result in an unrealistic intensity of seismic forces used in the design of superstructural elements. This can have dramatic consequences. As a typical example, the collapse of piers in Hanshin Express Highway during the 1995 Kobe earthquake (Fig. 1b) can be mentioned.



Figure 1. a) Collapse of the Showa Bridge during 1964 Niigata earthquake, source NISEE b) Collapse of piers in Hanshin Express Highway during 1995 Kobe earthquake, source Reuters

Seismic standard Eurocode 8 in its 5<sup>th</sup> part (hereinafter standard EC8-5 [1]) treats the seismic resistance of pile foundations in a quite limited and insufficient scope for practical application. Only some general rules and recommendations are given. The generally known division of the lateral seismic load of piles into kinematic and inertial components is defined. However, it is not defined what these components actually are. Also, it is not described how to determine these components and how the pile internal forces and deflections of these components can be superimposed. In most cases, the real seismic influences in the superstructure and pile foundation cannot be determined without a seismic SPS interaction analysis. This fact is more or less stated by the standard EC8-5 [1]. However, this standard does not propose a method or make any recommendations on how to analyse this interaction. Since this is a very complicated interaction, engineers in practice are in trouble. Also, a problem for engineers in practice is that the standard EC8-5 [1] analyses the participation of piles in the process of seismic energy dissipation on a quite limited scope. It is well-known that the appearance of a plastic hinge on a pile, most often at its upper end i.e. at the place where the pile is fixed into a pile cap, usually cannot be avoided during stronger earthquakes. How dangerous and problematic is the appearance of a plastic hinging on a pile as an element that is usually exposed to intense compressive force, is a troubling question for engineers in practice.

In the following, all previously mentioned shortcomings of the standard EC8-5 [1] related to the seismic resistance of pile foundations will be analysed in more detail. Since recently the standard Eurocode 8 is the only valid seismic standard in Montenegro, as well as in other ex-YU countries, paper of this type can be very useful for engineers in practice.

## 2. KINEMATIC AND INERTIAL LATERAL SEISMIC FORCES OF PILE FOUNDATIONS

In the professional literature, which is dealing with problems of seismic SPS interaction as well as in the standard EC8-5 [1], lateral seismic load of pile foundation is separated into the two components. These are the kinematic and inertial components. Kinematic lateral seismic forces arise as a consequence of the displacements (vibrations) of the foundation soil during an earthquake (Fig 2a). The piles are forced to more or less follow these displacements, which depends primarily on their relative stiffness (in relation to the surrounding soil). A relative displacement occurs between the surrounding soil and the piles. The kinematic lateral seismic forces are proportional to this relative displacement. Displacements of the piles caused by the displacements of the foundation soil during an earthquake are transferred to the superstructure. Displacements (vibrations) of the superstructure cause the appearance of inertial lateral seismic forces acting on it. However, these forces are also transferred to the piles via the pile cap, so the piles are exposed to "new" inertial lateral seismic forces from the superstructure (Fig. 2b). Therefore, kinematic and inertial seismic forces on the piles act simultaneously.

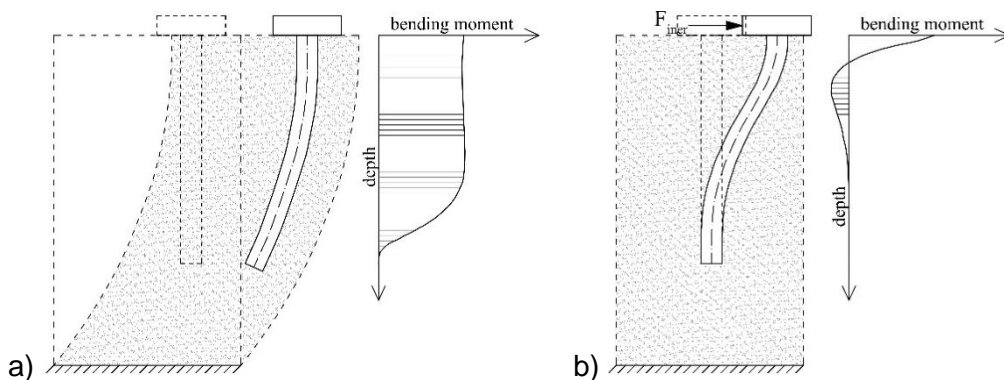


Figure 2. Deflection and bending moment diagram of fixed-headed pile due to the action of the a) kinematic lateral seismic forces b) inertial lateral seismic forces.

Adapted from [2]

Unfortunately, when it comes to kinematic and inertial seismic load of pile foundations, the situation is quite complicated. Kinematic lateral seismic forces are a direct consequence of the lateral displacements of the surrounding soil during an earthquake. Inertial lateral seismic forces are a direct consequence of the lateral displacements of the superstructure during an earthquake. However, these forces act simultaneously and are not independent of each other. The displacements of the surrounding soil during an earthquake are determined by a large number of factors. Among them are number of piles, relative stiffness of the piles, distance between the piles and the displacement of the piles caused by the inertial lateral seismic forces

from the superstructure. These inertial forces actually arise as a consequence of the displacements of foundation soil, which were transferred to the upper structure via the piles and pile cap. So, inertial forces arise as a consequence of the act of the kinematic forces.

### **3. ANALYSIS OF KINEMATIC AND INERTIAL SEISMIC SPS INTERACTION - CALCULATION MODEL AND LOADS**

In the last 40 years, many researchers around the world have analysed the problems of seismic SPS interaction using adequate numerical and/or physical models with the main goal of realistically and accurately estimating the seismic response of pile-supported structures [3-12]. However, all these researches have not yet resulted in any generally accepted method that would be implemented in seismic standards and that engineers could use in practice.

Taking into account all the methods for dealing with seismic SPS interaction, the so-called BDWF method (beam-on-dynamic-Winkler-foundation) is the most suitable for application in engineering practice. It is about pseudo-static pushover seismic analysis. There are several variants of this method that are very similar to each other. It is based on the assumption that the intensities of mutually dependent kinematic and inertial lateral seismic forces can be determined completely independently. The pile is modelled using beam finite elements with appropriate geometric and material characteristics. The inertial seismic load is applied as a horizontal force at the upper end of the pile. Kinematic seismic load is simulated by applying the envelope of the maximum seismic free-field soil displacements to the pile. However, this envelope of the maximum displacements is not applied directly to the pile but through a series of horizontal contact elements (Fig. 3). Variants of the BDWF method differ from each other depending on the adopted type of contact elements. These can be different nonlinear  $p$ - $y$  or  $p$ - $\delta$  springs. Among others, the application of springs whose mechanical behaviour is defined by a nonlinear  $p$ - $y$  diagram (curve) was proposed by: Metlock [13], Reese et al. [14], O'Neill & Gazioglu [15], Castelli and Maugeri [16], Dezi et al. [11]. Among others, the application of springs whose mechanical behaviour is defined by a nonlinear  $p$ - $\delta$  diagram (curve) was proposed by Jeong et al. [17] and Cubrinovski et al. [18]. It is useful to mention that the method proposed by Cubrinovski et al. [18], which treats the specific case of seismic SPS interaction with the occurrence of liquefaction in the foundation soil during an earthquake, is recommended by the New Zealand Transport Agency for use in engineering practice in the design of road and railway bridges. Unfortunately, the American national standards (ASCE standards) treat this problem in a quite limited and insufficient scope for practical application, similar to the standard EC8-5.

Many researchers believe that the most accurate and realistic results are provided by the variant of the BDWF method where the well-known Kelvin-Voigt elements with a constant spring stiffness  $k$  and a constant dashpot damping coefficient  $c$  are adopted for the contact elements (Fig. 3). Dashpot damping coefficient are defined depending on the main natural angular frequency of the foundation soil  $\omega$ . They studied this variant of the BDWF method in their research. Examples include: Makris & Gazetas [5], Mylonakis et al. [6], Nikolaou et al. [8] and Castelli et al. [19].

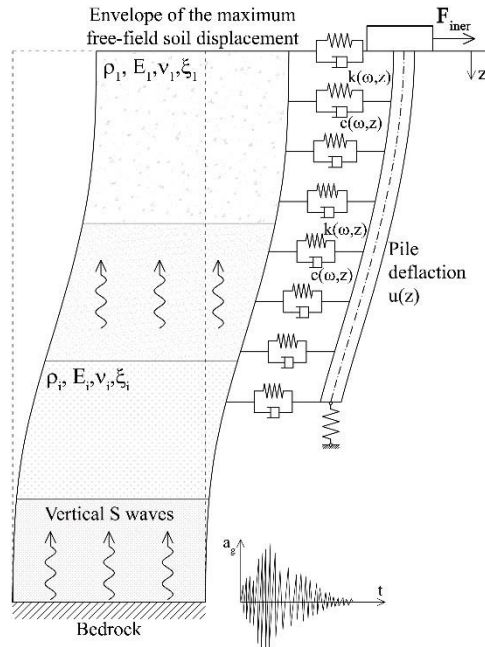


Figure 3. Schematic illustration of the BDWF method for seismic SPS interaction analysis. Adapted from [8, 19]

To determine the envelope of the maximum seismic free-field soil displacements, a well-known equivalent-linear analysis is usually used with the help of appropriate software (e.g EERA, SHAKE, DEEPSOIL and others). Castelli and Maugeri [16] note that the application of the envelope of the maximum free-field soil displacements at each depth does not always guarantee obtaining the maximum values of the "kinematic" bending moments in the piles. So, if there are possibilities, the time-history of the free-field soil displacements should be taken into consideration.

In older papers, such as [5, 20, 21], the following proposal can be found for determining spring stiffness  $k$  and a dashpot damping coefficient  $c$  for contact elements placed at the depth of the  $i$ -th layer of the foundation soil:

$$k_i = \delta \cdot E_{s,i} \quad (1)$$

$$c_i = 6 \cdot \left( \frac{\omega \cdot d_p}{V_{s,i}} \right)^{\frac{1}{4}} \cdot \rho_{s,i} \cdot V_{s,i} \cdot d_p + 2 \cdot \xi_{s,i} \cdot \frac{k_i}{\omega} \quad (2)$$

where  $E_{s,i}$  is the Young's modulus of the soil layer  $i$ ,  $\rho_{s,i}$  is the mass density of the soil layer  $i$ ,  $V_{s,i}$  is shear wave velocity of the soil layer  $i$ ,  $\xi_{s,i}$  is the damping ratio of the soil layer  $i$ ,  $\omega$  is main natural angular frequency of the foundation soil and  $d_p$  is pile diameter. The value of coefficient  $\delta$  varies from 1.0 to 1.2 for free-headed piles (without pile cap). The value of coefficient  $\delta$  varies from 1.5 to 2.5 for fixed-headed piles (with pile cap). More recently, new proposals for determining spring stiffness  $k$  and a dashpot damping coefficient  $c$  for contact elements placed at the depth of  $i$ -th layer of the foundation soil appear in professional literature. Karatzia and Mylonakis [22] propose the following expressions for free-headed piles:

$$k_i = \delta \cdot E_{sd,i} \quad (3)$$



$$c_i = \pi \cdot \rho_{s,i} \cdot V_{s,i} \cdot d_p \cdot \left( 0.25 + 0.8 \cdot \frac{V_{p,i}}{V_{s,i}} \right) \cdot \left( \frac{\omega \cdot d_p}{V_{s,i}} \right)^{-0.4} \quad (4)$$

where  $E_{sd,i}$  is the Young's modulus of the soil layer  $i$  at the depth of one pile diameter,  $V_{p,i}$  is compression wave velocity of the soil layer.

At first glance, it can be said that determining the inertial lateral seismic load of pile foundation is not problematic. It is about inertial lateral seismic forces that are transferred from the superstructure to the piles via the pile cap. However, things are far from simple. In order to determine the design seismic (inertial) load of the superstructure, which will be transferred to the piles via the pile cap, it is necessary to use an appropriate elastic acceleration response spectrum and an appropriate value of the behaviour (ductility) factor  $q$ . In other words, it is necessary to use an appropriate design (inelastic) acceleration response spectrum. However, elastic and inelastic acceleration response spectra for pile-supported structures do not exist.

The standard Eurocode 8 in its first part (hereinafter standard EC8-1 [23]) recommends (prescribes) the same elastic response spectra for all structures regardless of how they are founded, which is a rough assumption. Therefore, engineers in practice have a problem because they are not sure how to choose an adequate ground type i.e. the elastic response spectrum for pile-supported structure. Is it an unrealistic solution even in these situations, when choosing the ground type i.e. elastic response spectrum, to take into account all foundation soil layers up to a depth of 30m, as recommended (prescribed) by the standard EC8-1 [23]? This means taking into account the soft soil layers through which the piles only pass and which practically do not accept the loads from the superstructure. In other words, this proposal ignores the adopted type of foundation. On the other hand, is it a realistic and overly optimistic solution to completely ignore the soft foundation soil layers through which the piles pass and the ground type i.e. elastic response spectrum choose based on the characteristics of only the hard soil layer in which the piles are supported? Therefore, this proposal completely ignores the influence of soft soil layers. It is clear that in this way a "better" ground type will be obtained, which means less seismic load on the structure. If this solution is adopted, what should be done if that hard soil layer is at a depth greater than 30m, which is prescribed as the lower limit by the standard EC8-1 [23]? Be that as it may, it is clear that the characteristics of the seismic excitation that "goes" from the foundation soil to the structure depends more or less on the characteristics of the pile foundation. This primarily refers to the stiffness of the piles, the slenderness of the piles, their number and their mutual distance, as well as the position of the hard soil layer in which piles are supported in the relation to the bedrock.

The problem of determining the appropriate ground type i.e. appropriate design (inelastic) acceleration response spectrum for pile-supported structure are not recognized and treated for now by standard Eurocode 8 and ASCE standards. The New Zealand Seismic Standard with mark NZS 1170.5:2004 [24] in its supplement recognizes this problem and states without elaboration that the ground type should be adopted based on the characteristics of the shallower (surface) layers of the foundation soil. The exception is situations with very stiff piles, such as sleeved piles.

Research on the topic of inelastic response spectra of pile-supported structures has practically not been carried out so far. An exception is the research conducted by Nguyen et al. [25] and López Jiménez et al. [26] on numerical models of the

different SPS system. In these researches, among other things, a comparison of the acceleration response spectrum of the input seismic excitation given at the bedrock level in the horizontal direction and the obtained horizontal acceleration response spectrum of the pile-supported structure at the pile cap level was carried out. These researches has shown that the characteristics of the piles often have a significant influence on the intensity of the seismic excitation of the superstructure (Fig. 4).

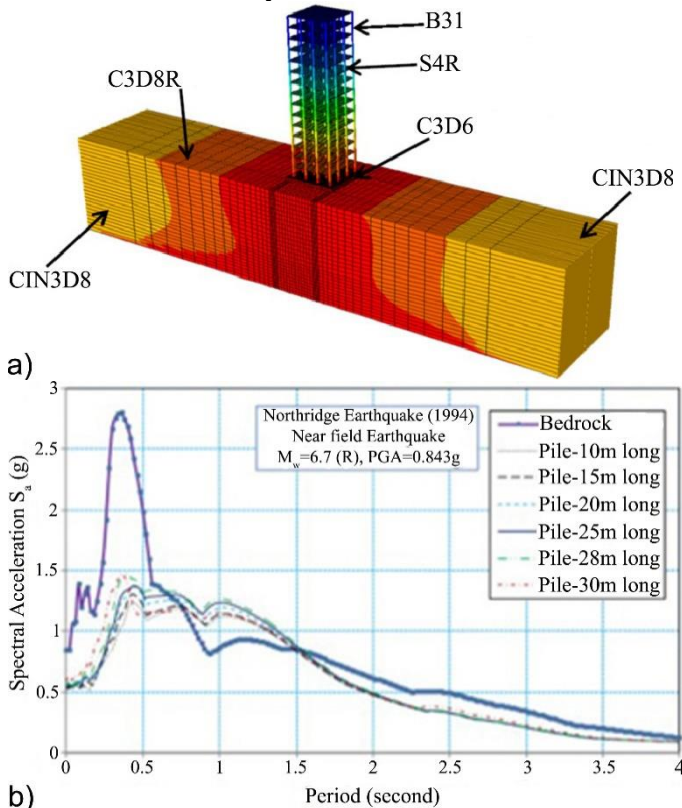


Figure 4. a) Numerical model for time-history analysis of seismic SPS interaction formed by Nguyen et al. [25] in Abaqus software with marks of applied types of finite elements b) Horizontal inelastic acceleration response spectra at the bedrock level and pile cap level [25]

The formation of numerical model of the SPS system shown above is very complicated primarily in terms of simulating the mechanical behaviour of the foundation soil during an earthquake, the way of applying seismic excitation and the way of simulating the contact of the surrounding soil and piles. In [25] a classical viscoelastic material model was used for the soil, which can be very problematic if larger shear deformations are generated in the soil during an earthquake (greater than approximately 0.1%), which is a very common case during stronger earthquakes. Simulating seismic excitation by applying accelerograms along the bottom contour of the numerical model in one or both horizontal directions (done in [25]), which is very popular among researchers, does not correspond to reality. Why? Because, in this way, it is actually assumed that all soil points at the same depth  $z$  have identical displacements during an earthquake. In other words, the influence of surface seismic waves, which can be extremely significant, was neglected. Also, it is important to note that the contact surfaces of the surrounding

soil and piles can be significant places of seismic energy dissipation, so the application of elastic contact elements (e.g elastic  $p$ - $y$  springs as in [25]) is not recommended.

#### 4. PARTICIPATION OF PILES IN THE PROCESS OF SEISMIC ENERGY DISSIPATION

The elastic behaviour of the piles during an earthquake is desirable and best possible. Unfortunately, in the case of stronger earthquake, it is very difficult to provide. This fact is recognized and confirmed by the standard EC8-5 [1]. Due to the action of primarily inertial lateral seismic forces, a plastic hinge usually occurs at the upper end of the pile i.e. at the place where the pile is fixed into a pile cap. If the general rules of pile reinforcement and the specific rules of reinforcement of potential plastic hinge zone are followed, the appearance of a plastic hinge at the upper end of the pile should not worry engineers in practice. The cross-section at the upper end of the pile has more than sufficient ductility (capacity of rotation), considering the values of the behaviour factor  $q$  of common RC structures (buildings, bridges, etc.). It is shown in Fig. 5, for the cross section of the pile exposed to different values of compressive force. Therefore, the seismic response of a pile with one plastic hinge formed (most often at the upper end) is not ideal, but it is an acceptable type of pile seismic response (Fig. 6a).

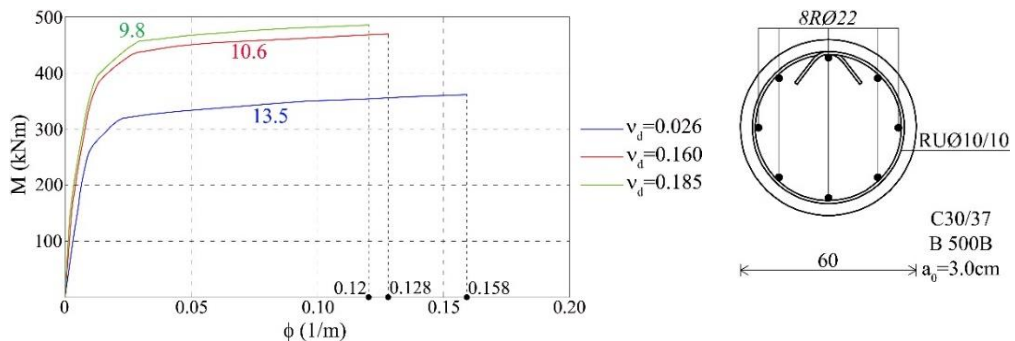


Figure 5. Moment-curvature diagrams and ductility factors for shown RC pile at different values of the design normalized compressive axial force  $v_d$

Today, in engineering practice, the kinematic seismic load of pile foundation is most often neglected without any valid justification. This neglect can be very problematic (dangerous) especially with longer piles. Why? Kinematic seismic lateral forces can be the cause of exceeding of the pile bending capacity (less often shear capacity) during a stronger earthquake. More precisely, kinematic seismic lateral forces can initiate the formation of an unfavourable (unacceptable) and very dangerous mechanism in pile which generally results in its collapse (Fig. 6b). What kind of mechanism is it? After a plastic hinge is formed at the upper end of the pile, the formation of a new plastic hinge anywhere along the pile would mean the formation of a mechanism that "seeks" such ductility (capacity of rotation) of the pile that is almost impossible to provide. This causes the failure (collapse) of pile. The part of the pile that is destined for the appearance of the second plastic hinge is the part of the pile in the zone around the border of the two layers of foundation soil with significantly different stiffnesses.

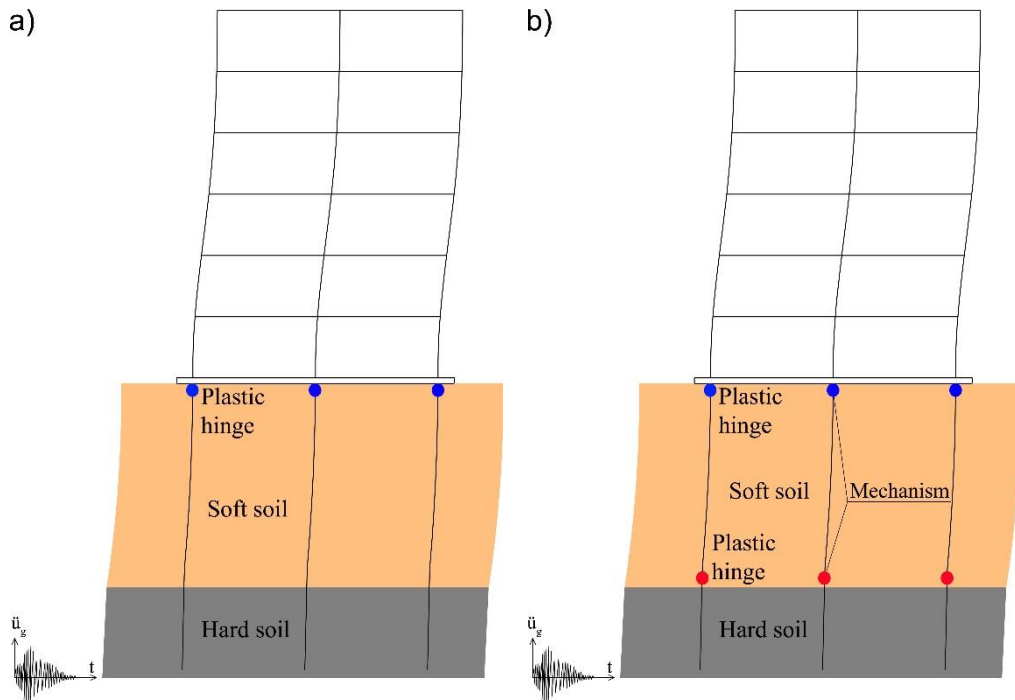


Figure 6. Seismic response of pile foundation a) acceptable b) unacceptable

For control of bending capacity of pile foundation during an earthquake i.e. for control of formation unaccepted mechanism in piles during an earthquake, authors of this paper suggested a simple and practical solution. This solution is based on the investigations that the authors of this paper carried out in the previous period [27, 28]. These investigations involved primarily conducting state-of-the-art analysis as well as a several analyses on appropriate numerical models. The previously described BDWF method is applied with certain corrections. At the upper end of the pile i.e. at the place where the pile is fixed into a pile cap, a classic hinge is modelled or the bending stiffness of the pile is drastically reduced (minimum 70%) in the zone of its upper end. Since some (significant) dissipation of seismic energy has already occurred in the superstructure and piles, the inertial lateral seismic load of the piles for the purposes of this control can be reduced. It is difficult to estimate exactly how much this load can be reduced. By orientation, the inertial load can be reduced from 30% to 60%. The kinematic lateral seismic load should not be reduced. Due to numerous unknowns when it comes to this control, the minimum value of the safety factor against the appearance of an unacceptable and dangerous mechanism in the pile is suggested to be 3.0.

## 5. CONCLUSION

In this paper, some of the most significant problems faced by civil engineers in practice when designing pile-supported structures in seismically active areas are analysed in more detail. The cause of these problems are the shortcomings of seismic standards in Montenegro and in general in the world. These are problems that primarily relate to the correct determination of the seismic load of the

superstructure and piles, as well as the problem of providing the necessary bending capacity for piles under the action of seismic load. Concrete proposals and suggestions are given to overcome these problems, which can be very important to engineers in practice.

## REFERENCES

- [1] European Committee for Standardization: EN 1998-5: Design of structures for earthquake resistance – Part 5: Foundations, retaining structures and geotechnical aspects. Brussels, Belgium, 2004.
- [2] Laora Di Raffaele, Mylonakis George, Mandolini Alessandro: **Size Limitations for Piles in Seismic Regions**. *Earthquake Spectra*, Vol. 33, No. 2, 729–756, 2017.
- [3] Margason Edward: **Pile bending during earthquakes**. ASCE-UC/Berkeley Seminar on Design Construction and Performance of Deep Foundations, Berkeley, California, 1975.
- [4] Gazetas George: **Seismic response of end-bearing single piles**. *Soil Dynamics and Earthquake Engineering*, Vol. 3, No.2, 82-93, 1984.
- [5] Makris Nicos, Gazetas George: **Dynamic pile-soil-pile interaction - Part II: Lateral and seismic response**. *Earthquake Engineering and Structural Dynamics*, Vol. 21, 145-162, 1992.
- [6] Mylonakis George, Nikolaou Aspasia, Gazetas George: **Soil-pile-bridge seismic interaction: kinematic and inertial effects - Part I: Soft soil**. *Earthquake Engineering and Structural Dynamics*, Vol. 26, 337-359, 1997.
- [7] Boulanger W. Ross, Curras J. Christina, Kutter L. Bruce, Wilson W. Daniel, Abghari Abbas: **Seismic Soil-Pile-Structure Interaction Experiments and Analyses**. *Journal of Geotechnical and Geoenvironmental Engineering*, Vol. 125, No. 9, 750-759, 1999.
- [8] Nikolaou Sissy, Mylonakis George, Gazetas George, Tazoh Takashi: **Kinematic pile bending during earthquakes: analysis and field measurements**. *Géotechnique*, Vol. 51, No. 5, 425-440, 2001.
- [9] Bhattacharya Subhamoy: **Pile instability during earthquake liquefaction**. *PhD dissertation*, University of Cambridge, Cambridge, UK, 2003.
- [10] Madabhushi Gopal, Knappett Jonatan, Haigh Stuart: **Design of pile foundations in liquefiable soils**. *Imperial College Press - 1st edition*, 2009.
- [11] Dezi Francesca, Carbonari Sandro, Leoni Graziano: **Static equivalent method for the kinematic interaction analysis of single piles**. *Soil Dynamics and Earthquake Engineering*, Vol. 30, 679–690, 2010.
- [12] Hussien N. Mahmoud, Karray Mourad, Tobita Tetsuo, Iai Susumu: **Kinematic and inertial forces in pile foundations under seismic loading**. *Computers and Geotechnics*, Vol. 69, 166–181, 2015.
- [13] Matlock Hudson: **Correlations for design of laterally loaded piles in soft clay**. *Second Annual Offshore Technology Conference*, Houston, Texas, Paper No. UTC 1204, 577-595, 1970.
- [14] Reese C. Lymon, Cox R. William, Koop D. Francis: **Field testing and analysis of laterally loaded piles in stiff clay**. *The Offshore Technology Conference*, Houston, Texas, Paper No. OTC 2312, 671–690, 1975.
- [15] O'Neill W. Michael, Gazioglu Sal: **Evaluation of p-y relationships in cohesive soils**. *The ASCE symposium on analysis and design of pile foundations*, San Francisco, California, 192–213, 1984.

- [16] Castelli Francesco, Maugeri Michele: **Simplified Approach for the Seismic Response of a Pile Foundation**. *Journal of Geotechnical and Geoenvironmental Engineering*, Vol. 135, No. 10, 1440-1451, 2009.
- [17] Jeong Sangseom, Kim Byungchul, Won Jinoh, Lee Jinhung: **Uncoupled analysis of stabilizing piles in weathered slopes**. *Computers and Geotechnics*, Vol. 30, No. 8, 671–682, 2003.
- [18] Cubrinovski Misko, Ishihara Kenji, Poulos G. Harry: **Pseudo-static analysis of piles subjected to lateral spreading**. *Bulletin of the New Zealand Society for Earthquake Engineering*, Vol. 42, No. 1, 28-38, 2009.
- [19] Castelli Francesco, Maugeri Michele, Mylonakis George: **Numerical analysis of kinematic soil-pile interaction**. *Seismic Engineering Conference Commemorating the 1908 Messina and Reggio Calabria Earthquake*, Reggio Calabria, Italy, Paper No. CP1020, 618-625, 2008.
- [20] Kagawa Takaaki, Kraft M. Leland: **Lateral load-deflection relationships of piles subjected to dynamic loadings**. *Soils and Foundations*, Vol. 20, No. 4, 19-36, 1980.
- [21] Nogami Toyoaki, Novak Milos: **Coefficients of soil reaction to pile vibration**. *Journal of Geotechnical Engineering Division*, Vol. 106, No. 5, 565–570, 1980.
- [22] Karatzia Xenia, Mylonakis George: **Horizontal response of piles in inhomogeneous soil: simple analysis**. *Second International Conference on Performance Based Design in Earthquake Geotechnical Engineering*, Taormina, Italy, Paper No 1117, 1-16, 2012.
- [23] European Committee for Standardization: EN 1998-1: Design of structures for earthquake resistance – Part 1: General rules, seismic actions and rules for buildings. Brussels, Belgium, 2004.
- [24] New Zealand Standards Technical Committee BD-006-04-11: NZS 1170.5 Supplement 1: Structural design actions – Part 5: Earthquake actions – New Zealand – Commentary, 2004.
- [25] Nguyen Van Quoc, Fatahi Behzad, Hokmabadi S. Aslan: Influence of Size and Load-Bearing Mechanism of Piles on Seismic Performance of Buildings Considering Soil–Pile–Structure Interaction. *International Journal of Geomechanics*, ASCE, ISSN, 1532-3641, 2017.
- [26] López Jiménez A. Guillermo, Dias Daniel, Jenck Orianne: **Effect of the soil-pile-structure interaction in seismic analysis: case of liquefiable soils**. *Acta Geotechnica*, Vol. 14, 1509-1525, 2019.
- [27] Miladinović Borko: **Nosivost vertikalnih šipova pod dejstvom horizontalnih sila u uslovima pojave likvefakcije u tlu**. Magistrski rad, Građevinski fakultet Univerziteta Crne Gore, Podgorica, 2015.
- [28] Tomanovic Zvonko: Testing of allowable bearing capacity of vertical piles under lateral static load on the docks of the mega-yacht marina Porto Montenegro, Tivat, Montenegro. *Materials and Structures*, Vol. 3, 65-81, 2011.

# ANALYSIS OF THE BEARING CAPACITY OF A MASONRY WALL UNDER THE ACTION OF AN EARTHQUAKE THAT HAPPENED IN TURKEY IN 2023

Faris Trešnja<sup>1</sup>

## Abstract

*This paper presents the bearing capacity of a masonry wall with and without concrete cerclage under earthquake. The devastating earthquake that occurred in Turkey (Hatay) in 2023 was applied in Extreme Loading for Structures (ELS) which is based on the applied element method (AEM), a derivative of the finite element method (FEM) and the discrete element method (DEM). ELS enabled the study of the behavior of the wall through the continuum phase and the discrete phase of loading, which is of great importance during the formation of cracks, the separation of blocks and finally the collapse of the structure.*

**Key words:** masonry wall, concrete cerclage, earthquake, seismic resistance, AEM

---

<sup>1</sup> MA, assistant, The Faculty of Civil Engineering of the University 'Džemal Bijedić' in Mostar, faris.tresnja@unmo.ba

## 1. INTRODUCTION

Horizontal and vertical cerclages must be interconnected with reinforcement. The upper horizontal and lateral vertical cerclages must be performed after the masonry has been built so that they will be properly connected to each other. Before concreting the vertical cerclages, time is given to the mortar in the wall to dry, and for most of the deformation due to shrinkage to occur. It is important to note that vertical and horizontal cerclages do not have the effect of a frame structure, but together with the masonry, they give the masonry structure greater load-bearing capacity and ductility. They are usually the same or less thick than the thickness of the wall, and sometimes their presence in the wall is not visible because they are hidden in the cavities of specially shaped wall elements. If the floor collapses due to an extraordinary load, the horizontal cerclages must be able to take the upper load. Figure 1 shows the difference between confined masonry wall and reinforced concrete frame.

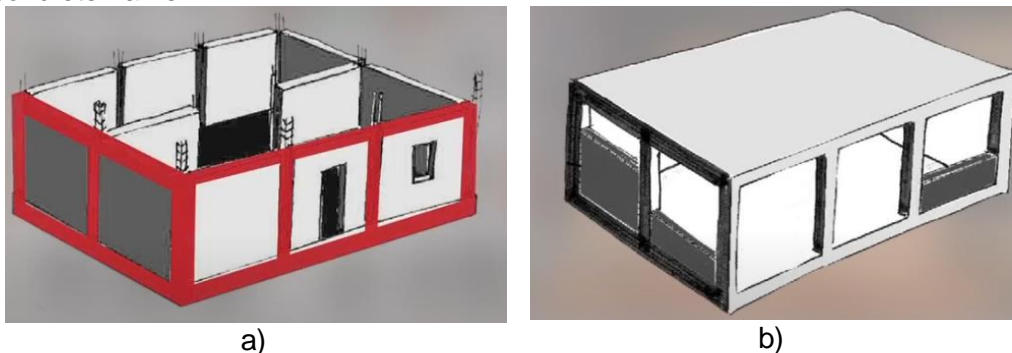


Figure 1. a) Confined masonry wall; b) Reinforced concrete frame

## 2. APPLIED ELEMENT METHOD (AEM)

Computer simulation is an important key in determining the performance of structures in extreme loading conditions. However, it is not possible to predict the behavior of collapse for structures using the Finite Element Method. Reviewing the current literature, it is noticed that methods used for structural analysis are mainly based on continuum mechanics rules, like the Finite Element Method, which cannot be applied explicitly to discrete elements. Therefore continuum mechanics-based methods cannot be extended to simulate the collapse analysis. On the other hand, analysis methods based on rules of discrete elements cannot be used to predict behavior of continuum elements. As a matter of fact, structures during a collapse situation pass through the two stages: a continuum stage followed by a discrete stage. The analysis and simulation needs to follow both behavior stages in order to help in answering the following questions:

- Will the structure collapse during an extreme loading event?
- Will the collapse be partial or total?
- What is the mode of collapse of the structure?
- In cases of partial collapse, will it be possible to repair the structure?
- How long would it take for the structure to completely collapse?



- How does falling debris affect adjacent structures?
- What is the footprint affected by the collapse of a structure?

These questions are a small sample of questions that cannot be answered without having an accurate prediction of the structural performance when subjected to an extreme loading. A new method, that is capable of predicting to a high degree of accuracy the continuum and discrete behavior of structures, has been developed. Through two decades of continuous development, the Applied Element Method (AEM) was proven to be the method that can track the structural collapse behavior passing through all stages of the application of loads: elastic stage, crack initiation and propagation in ceramic materials, reinforcement and structural steel yielding, element separation, element collision (contact), and collision with the ground and with adjacent structures. The possible analysis domain of AEM in comparison to FEM is shown in figure 2. Although the FEM is accurate and reliable for analysis of continuum structures, the onset of element separation is difficult to automate and modeling of debris collision is time consuming.

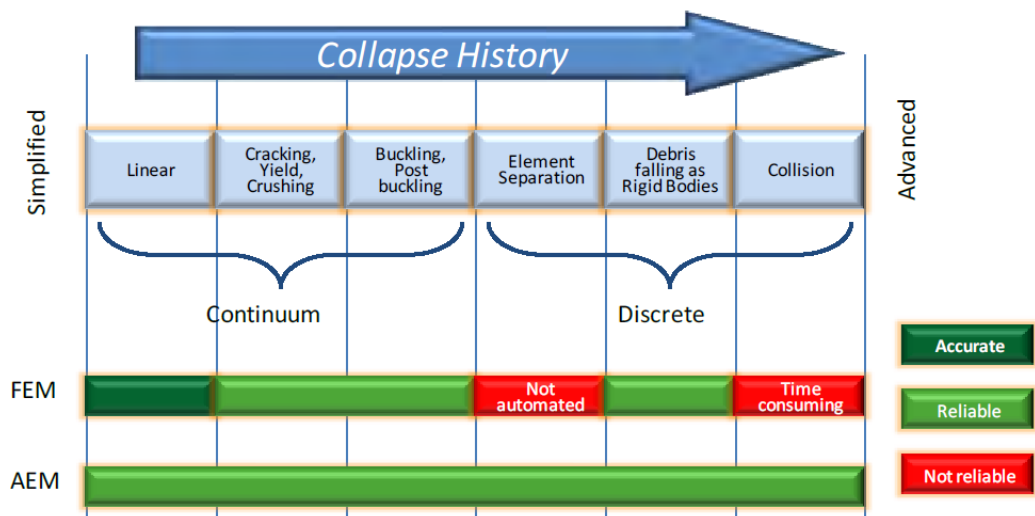


Figure 2. Analysis domain of AEM compared to FEM [1]

International publications in the area of structural engineering verify that the AEM can cover with a reasonable accuracy the fields of application. The method accuracy is compared with more than 50 experimental and theoretical results [2-6]. Literature surveys indicate that no other simulation technology has comparable overall performance to AEM. The AEM is the base method to analysis of structures under extreme loadings. Table 1 shows a brief comparison between the AEM and the FEM.

Table 1. Comparison between AEM and FEM analysis [1]

Subject of comparison	AEM	FEM
Calculation time	Briefly	Briefly
Degrees of freedom of movement	6 per element	24 per element (8-node element)
Cracking model	Discrete (physical) cracks	Discrete cracks whose location should be predicted in advance
	No need for connecting elements	Connecting elements are needed in places of wide cracks to simulate physical cracks
	Cracks can spread at the boundaries of the elements in any direction	Cracks cannot spread from one element to another, making the structure inseparable in arbitrary locations
	Crack expansion can be monitored	The spread of cracks cannot be precisely traced.
Preprocessing time	Briefly	Long
Reinforcement	All the details of the reinforcement are taken into account, for each bar of reinforcement. For example, the diameter of the rod and the protective layer of concrete can be taken into account.	It is very difficult to accurately calculate the details of the reinforcement because the properties should be added at the locations of the integration points
Before the collapse	High precision	High precision
During and after the collapse	High precision	Inability to track the collapse of the structure

With AEM, the structure is modeled as an assembly of small elements, which are made by dividing the structure virtually, as shown in figure 2. The two elements shown in figure 2 are assumed to be connected by one normal and two shear springs located at contact points, which are distributed around the elements edges. Each group of springs completely represents stresses and deformations of a certain volume as shown in figure 3.

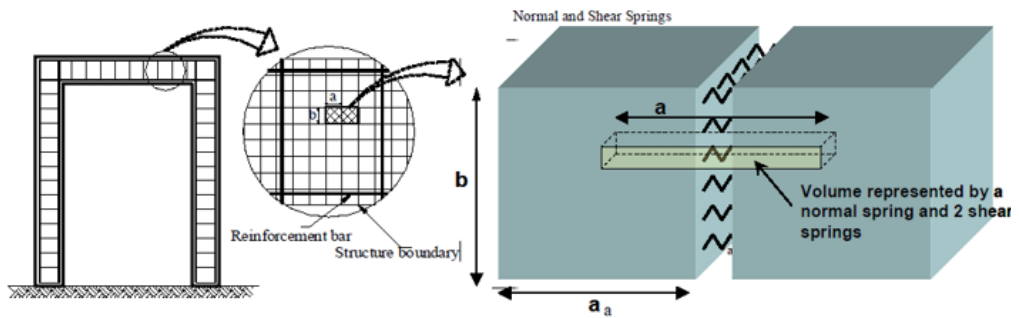


Figure 3. Modeling of the structure according to AEM [1]

### 3. ANALYSIS IN EXTREME LOADING FOR STRUCTURES SOFTWARE

In this research, the record of the devastating earthquake with a magnitude of 7.4 on the Richter scale, which hit the southern regions of Turkey and the northern border regions of Syria at the beginning of February 6, 2023, was selected for analysis. A 25-second record with a peak ground acceleration of  $8,40 \text{ m/s}^2$  was selected (figure 4).

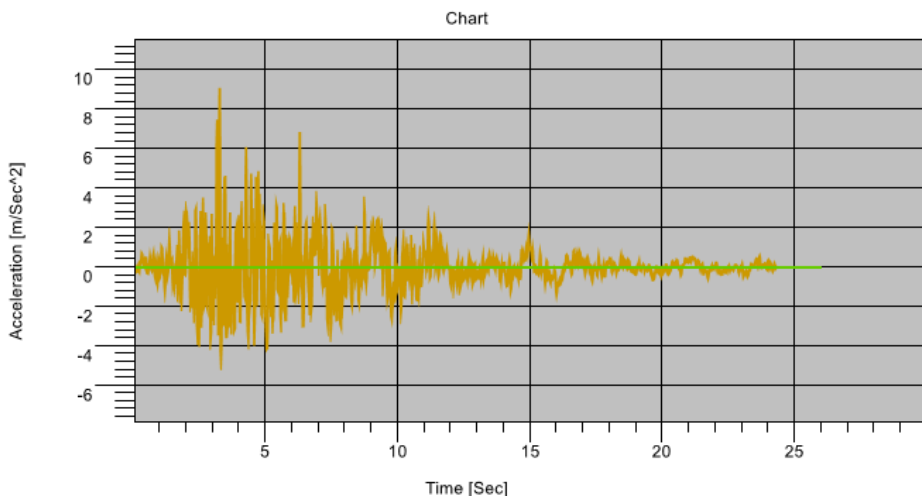


Figure 4. Part of the Hatay earthquake record [7]

Four cases are modeled and analyzed in the Extreme Loading for Structures software:

Case 1: masonry wall without concrete cerclage (length 5 m, height 4 m)

Case 2: masonry wall without concrete cerclage (length 5 m, height 2 m)

Case 3: masonry wall with concrete cerclage (length 5 m, height 4 m)

Case 4: masonry wall with concrete cerclage (length 5 m, height 2 m)

Table 2. The input parameters used in the analysis.

Parameter	Value		
	Bricks	Mortar	Reinforcement
Modulus of elasticity	15800 MPa	26200 MPa	199947
Shear modulus	7839 MPa	10480 MPa	79979
Separation deformation	0,1	0,1	1
Friction coefficient	0,8	0,8	0,8
Specific weight	1800 kg/m <sup>3</sup>	2500	7840
External damping coefficient	0	0	0
Normal contact stiffness factor	0,0001	0,0001	0,0001
Shear contact stiffness factor	0,00001	0,00001	0,00001
Stiffness factor when unloading the contact spring	2	2	2
Stiffness factor when unloading the contact spring	0,0000145	0,0000145	0,000013
Tensile strength	0,98 MPa	1,5 MPa	
Compressive strength	9,80 MPa	15 MPa	
Yield Stress	-	-	353 MPa
Ultimate Strain	-	-	0,15
Post Yield Stiffness Ratio	-	-	0,01
Ultimate/Yield Stress Ratio	-	-	1,4
Minimum normal stiffness factor	0,01 MPa	0,01	
Minimum shear stiffness factor	0,01 MPa	0,01	
Shear strength	2,45 MPa	375000	
Residual shear strength factor	0	0	
Failure Softening Factor	-	-	0,1
Shear Stress Weight	-	-	1
Poisson's ratio	0	0	0

### 3.1. Case 1: masonry wall without concrete cerclage (length 5 m, height 4 m)

During the earthquake, the wall for this case was overturned in the tenth second. The maximum stress was 48,78 MPa and maximum displacement of 4,21 m.

The picture below shows the principal stresses, strains and displacements in the fifth second of the earthquake's duration.

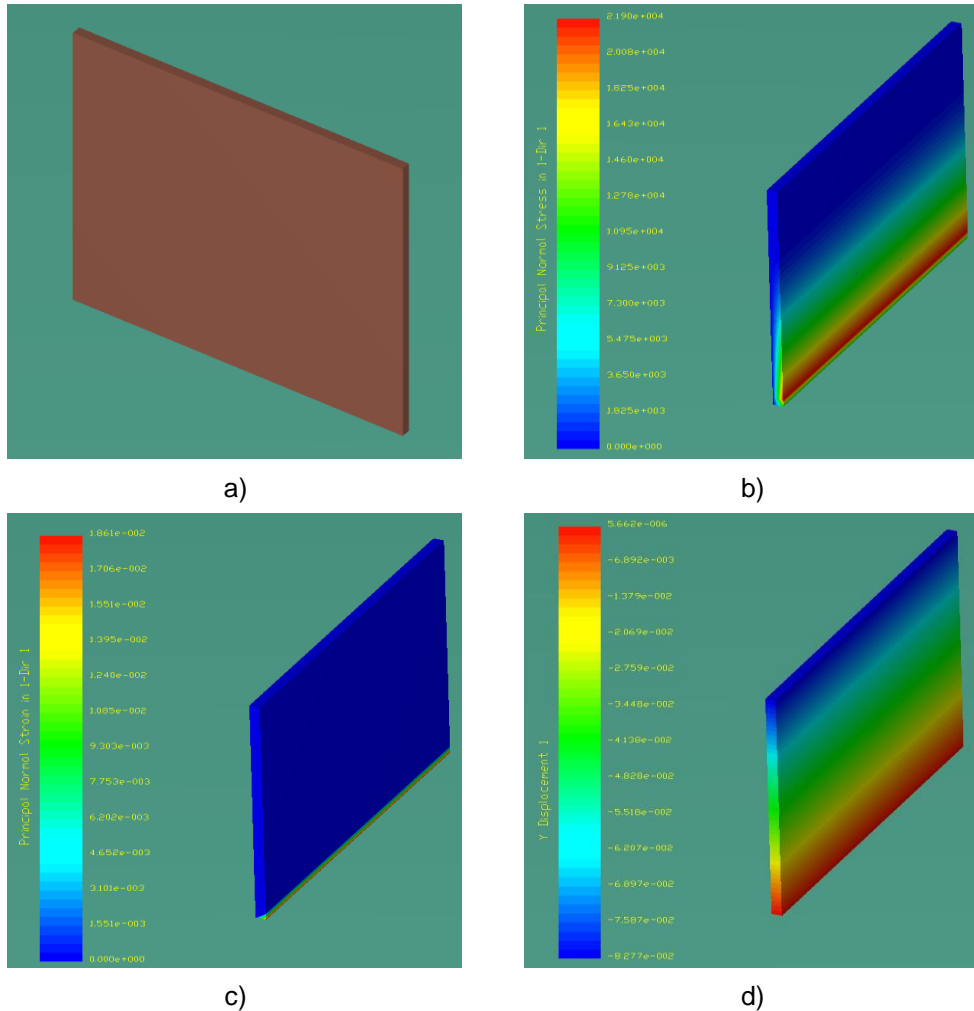


Figure 5. a) model for case 1; b) principal normal stress [kg/m<sup>2</sup>]; c) principal normal strain; displacement [m] [7]

### 3.2. Case 2: masonry wall without concrete cerclage (length 5 m, height 2 m)

During the earthquake, the wall didn't collapse in this case. The maximum stress was 1,16 MPa and maximum displacement of 0,06 m.

The figure below shows the principal stresses, magnitudes and displacements in the fifth second of the earthquake duration.

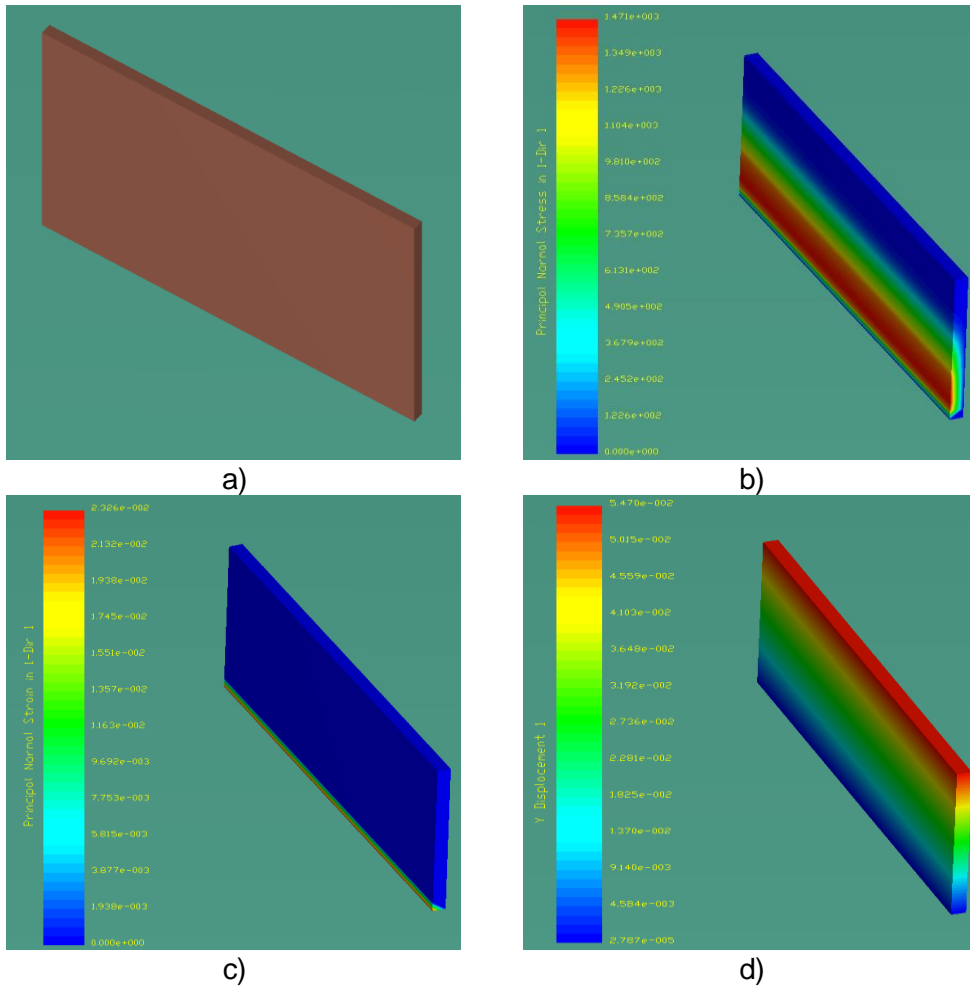


Figure 6. a) model for case 2; b) principal normal stress [kg/m<sup>2</sup>]; c) principal normal strain; displacement [m] [7]

### 3.3. Case 3: masonry wall with concrete cerclage (length 5 m, height 4 m)

During the earthquake, the wall didn't collapse in this case. The maximum stress was 4,87 MPa and maximum displacement of 0,028 m. 4Ø14 bar and Ø 8/15 stirrups were used in vertical and horizontal cerclages

The figure below shows the principal stresses, magnitudes and displacements in the fifth second of the earthquake duration.

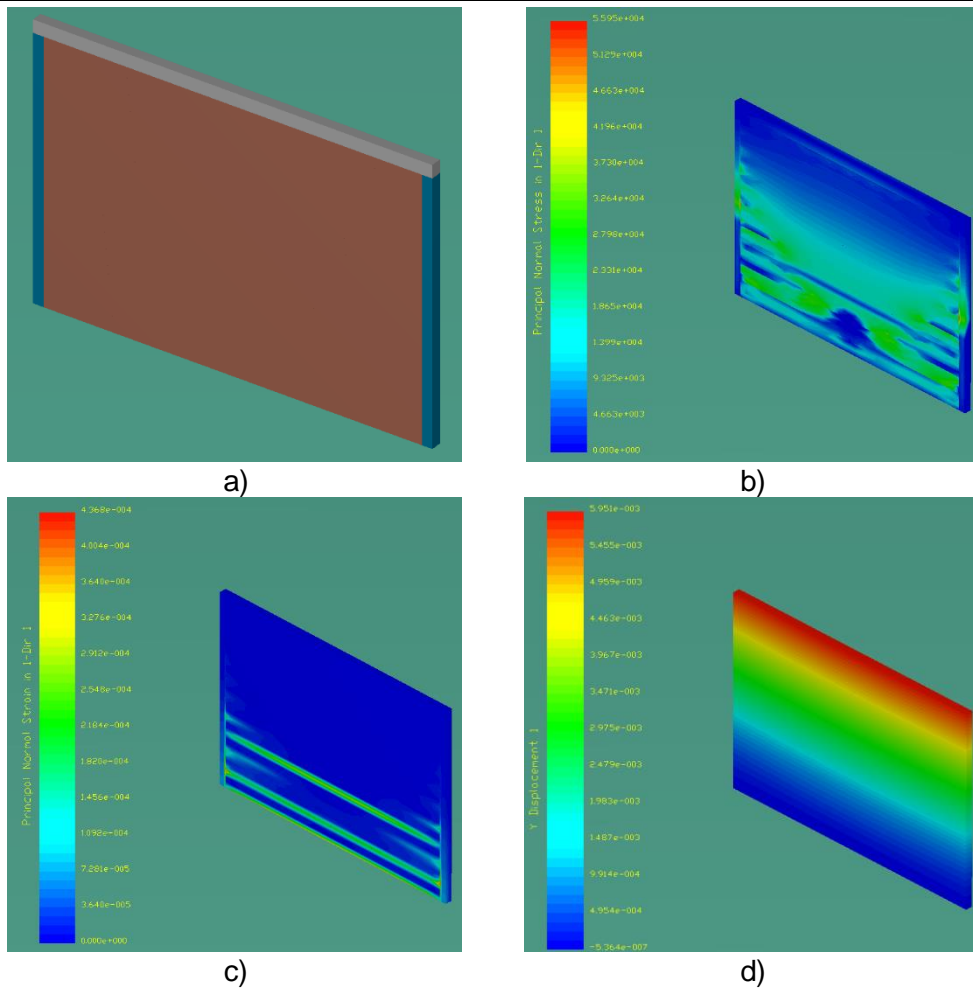


Figure 7. a) model for case 3; b) principal normal stress [kg/m<sup>2</sup>]; c) principal normal strain; displacement [m] [7]

#### 3.4. Case 4: masonry wall with concrete cerclage (length 5 m, height 2 m)

During the earthquake, the wall didn't collapse in this case. The maximum stress was 4,74 MPa and maximum displacement of 0,004 m. 4Ø14 bar and Ø 8/15 stirrups were used in vertical and horizontal cerclages

The figure below shows the principal stresses, magnitudes and displacements in the fifth second of the earthquake duration.

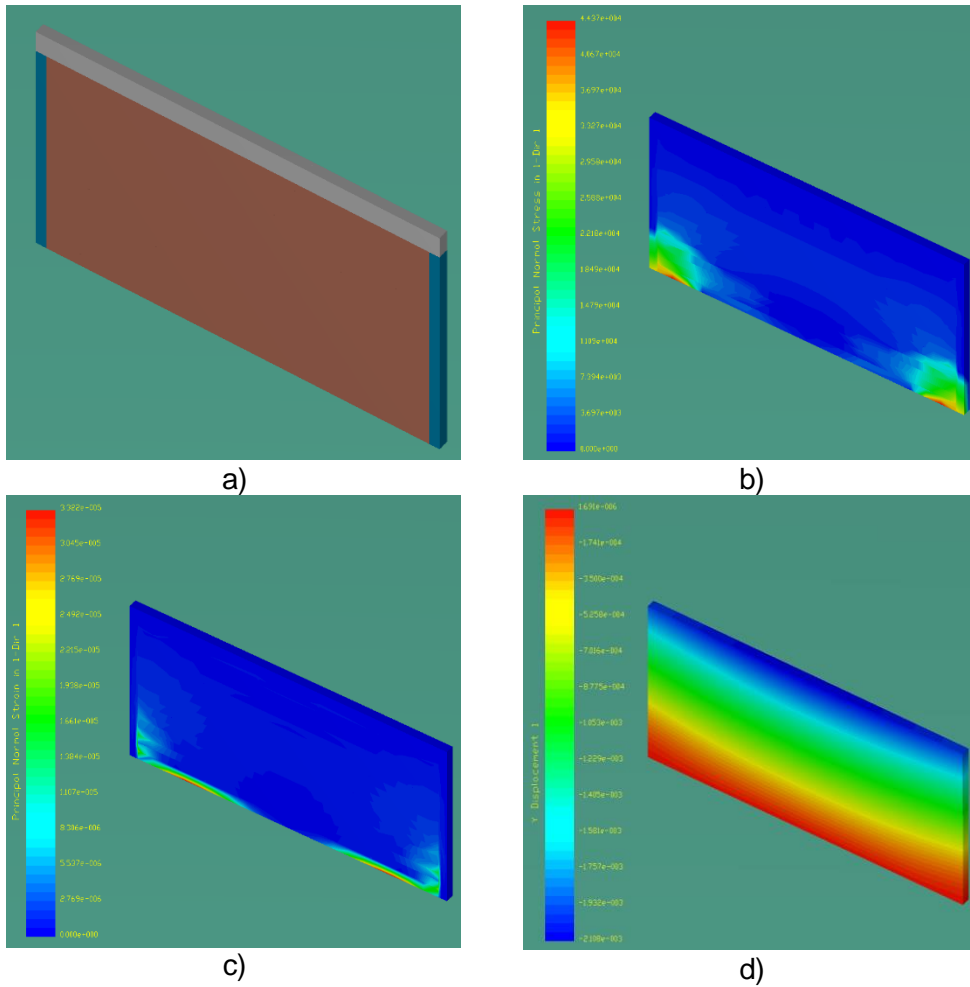


Figure 8. a) model for case 4; b) principal normal stress [kg/m<sup>2</sup>]; c) principal normal strain; displacement [m] [7]

#### 4. CONCLUSION

In the conducted analysis, it was shown how concrete cerclages affect the bearing capacity and stability of the masonry wall. In the first case, where there was no concrete cerclage and with a higher wall height, the wall collapsed. With the reduction of the height of the wall and with the setting concrete cerclages, the maximum displacements of the wall are reduced as shown in table 3.

Table 3 shows the input parameters used in the analysis.

	Maximum stress [MPa]	Maximum displacement [m]
Case 1	48,71	Collapse
Case 2	1,16	0,06
Case 3	4,87	0,028
Case 4	4,74	0,004



It is important to emphasize once again that vertical and horizontal cerclages increase the load-bearing capacity, stability and ductility of the masonry wall and they don't have the effect of a frame structure.

## REFERENCES

- [1] Theoretical Manual. Extreme Loading for Structures. Version 9. 2022.
- [2] Hamed Salem, Gregori, Huda Helmy, H, Khaled Fassieh, Hatem Tagel-Din, H: **Seismic Assessment of the Damaged Margherita Palace.** In *Proceedings of the 16th World Congress on Earthquake Engineering (16WCEE)*, Santiago, Chile, 9–13 January 2017.
- [3] Yves Reuland, Y, Abdo Abou Jaoude, Pierino Lestuzzi, Ian FC Smith. **Usefulness of ambient-vibration measurements for seismic assessment of existing structures.** In *Proceedings of the Fourth International Conference on Smart Monitoring, Assessment and Rehabilitation of Civil Structures (SMAR)*, Zurich, Switzerland, 13–15 September 2017; p. 162.
- [4] Gilbert Belec. **Seismic Assessment of Unreinforced Masonry Buildings in Canada.** Master's Thesis, University of Ottawa, Ottawa, Canada January 2016. Available online: <https://ruor.uottawa.ca/handle/10393/34301> (accessed on 5 November 2022).
- [5] Huda Helmy, Hamed Salem, Hatem Tagel-Din. **Numerical Simulation of Charlotte Coliseum Demolition Using the Applied Element Method.** In *Proceedings of the 6th International Engineering and Construction Conference (IECC'6)*, Cairo, Egypt, 28–30 June 2010; pp. 528–537.
- [6] Faris Trešnjó, Mustafa Humo, Filippo Casarin, Naida Ademović. **Experimental Investigations and Seismic Assessment of a Historical Stone Minaret in Mostar.** *Buildings* 2023, 13, 536. <https://doi.org/10.3390/buildings13020536>
- [7] Extreme Loading® for Structures Software (ELS Software). 2021. Available online: <https://www.appliedscienceinteurope.com/extreme-loading-for-structures/> (accessed on 6 November 2022).

# MARKETING SPECIALIZED IN THE FIELD OF CONSTRUCTION AND ARCHITECTURE TO CREATE AN INTERACTIVE RELATIONSHIP IN THE REAL ESTATE MARKET

Ljiljana Stošić Mihajlović<sup>1</sup>, Marija Mihajlović<sup>2</sup>

## Abstract

*The main characteristics of modern business conditions are the rapid spread of information, social networking, ubiquitous Internet, increasing information literacy and general awareness of people, which directly affects marketing communication, that is, marketing in general. Traditional marketing techniques are no longer popular in the field of architecture and construction, especially with real estate buyers, because today's buyer is more informed, can't be fooled, knows what he wants and makes smarter buying decisions. Real estate buyers today want and demand the right information, information that will make the most sense for them, that will solve their problem. The new marketing reality in the field of architecture and construction is to provide information and help customers to solve their requirements. Short and simple - digital marketing in the field of architecture and construction is internet advertising of specific products and services of these products, which form of marketing dominates today. The new model of advertising on the Internet is not based on promotions, persuasion and messages, but aims to deliver content at the time and place where it is requested. Success requires focusing on customers and their problems.*

**Key words:** *Digital marketing, real estate market, social networks, architecture, construction industry*

---

<sup>1</sup> Academy of technical educational studies, Niš – department in Vranje,

<sup>2</sup> Ministry of Construction, Transport and Infrastructure of Serbia, Belgrade

## 1. INTRODUCTION

Digital marketing or so-called e-marketing implies a set of marketing processes that use all available digital channels to promote products or services and how a certain message would reach the primary audience, mainly for brand building. They are today we have at our disposal thousands of different online channels through which anything can be done in order to service users. Today it is the majority of companies switched to advertising through various forms of digital marketing, and fewer and fewer companies use newspaper ads - precisely because people use the Internet more and more today and the information age is the fastest growing phenomenon known to society. In modern economic theory and practice, the concept of the triangle "market-marketing-trade" is very important and present. First of all, the importance of the connection between these three categories, and then the key roles they play in marketing channels [1].

Digital marketing represents the use of information technology in the process of creation, communication, and delivery of value to clients, and is the result of informative technologies applied to traditional marketing. The average global marketer invests an average of 20% to 35% of their budget in digital marketing, depending on the category of products or services it sells. When we talk about the Internet and in general about the e-commerce that we mentioned above, we can define: it implies the sale of goods/services through electronic channels of communication, primarily the Internet, and the name is short for electronic commerce. Created is as a result of the need to efficiently satisfy the needs of modern consumers which require salespeople to be available 24/7 a week, worldwide. Today, almost all products/services can be sold electronically; from books to music, clothes and shoes, air, and other transportation. The largest and most famous electronic retailers in the world are Amazon and eBay [2]. Digital marketing in the field of architecture and construction is of essential importance for the advancement of companies in this field. It offers the opportunity to communicate directly with potential clients, to improve the company's visibility; to monitor the performance of marketing campaigns and the results of investments in them; to create a long-term relationship with clients. All this leads to an increase in the number of clients and new business. Construction companies that do not use digital marketing are missing out on a huge opportunity to expand and grow their business. Building an online presence, using Search engine optimization (SEO) content, using social media and advertising are just some of the tactics that can help your business become more successful in digital marketing. The most important thing is to understand the needs and wants of the target audience in order to adapt the content and marketing strategy.

## 2. DIGITAL MARKETING

The basis of all modern marketing is human needs - consumer needs. They form the essence of the marketing concept. The key to the survival, profitability and development of the company, despite the highly competitive marketing environment, lies in its ability to identify and satisfy unfulfilled consumer needs, and all this in a shorter time and in a better way than competing companies. Providers do not create needs, although in some cases they can lead consumers to be interested in those

needs that they did not feel before. Successful bidders define their markets in relation to the needs they plan to meet, not in relation to the products they sell. This approach to marketing is, therefore, focused on the market and not on the product. Marketing orientation concentrates on consumer needs; production orientation concentrates on the needs of the seller. The marketing concept suggests that the producer will only produce what he knows people will buy, while the production orientation implies that the producer will try to sell what he initially decides to produce. [3]

Marketing has always been about connecting with your audience in the right place at the right time. In the present, that means reaching them where they spend most of their time: on the Internet. Digital marketing encompasses all marketing efforts that use an electronic device or the Internet. Companies are leveraging digital channels like search engines, social media, email and their websites to connect with current or potential customers. It reduces the cost of communication service because the internet is much cheaper and, in some cases, even free. E-marketing offers more flexibility, which allows the marketer to constantly adjust its offer and programs. The advantages of advertising on the web are low costs and the possibility of creating ads that will contain both sound and images, and the possibility of finding another page with additional, complex content. From the marketing side of social networks, many audiences use them to discover, search and educate themselves about a brand. Therefore, it is important to engage in that area as well. This practice promotes branding and content to social media channels to increase brand awareness, drive traffic and generate business leads. Channels used in social media include Facebook, Twitter, LinkedIn, Instagram, Snapchat, Pinterest, Google+, YouTube, and more. The advantages of social network marketing are relatively low campaign costs, quick feedback, increased traffic to the website, strengthening of the brand, simple and quick launch of new products or services. Using digital marketing, it is possible to measure the influence of all channels, e.g. the number of visitors to the page, the time spent on the page, what exactly is viewed, and based on that calculate profitability and what else can be changed to improve it. For the firm, the most important thing is reduced costs, because the effectiveness of each channel can be measured, and you can focus only on profitable channels and ignore the others. An easier increase in income can be achieved by collecting the data that the user has searched for on the web shop, and in this way discounts are sent to him via e-mail.

On the Internet, it is important to be found on a search engine. Increasing search engine visibility is not possible without quality content. Creating fresh and quality content should be edited in the form of image ads that offer discounts on furniture purchases, discount coupons, image galleries, videos and blogs. By editing quality content, the target groups are again influenced. Retargeting allows marketers to show ads to customers who have been on a website while others are online. These ads often show specific products that a customer has viewed. It's a great way to drive conversions and make up for potential lost sales.

### **2.1. Advantages of digital marketing**

Once upon a time, marketing simply meant advertising, and advertising was once a must address the masses. Advertising relied on sudden intrusions that would force people to they pay attention to some message, which they don't really expect or look for at that moment. Also, advertising was one-way: from the company to the

customer, and it was dealt with exclusively by selling products and was based on campaigns of limited duration, and creativity was considered the most important component of advertising. All that together today it is no longer valid. The Internet has changed the rules, and now marketing must change as well in order to make the most of the offered online marketplace of ideas.

A great advantage of digital marketing is the greater ability to monitor the success of campaigns and activities and a much lower cost of promotion. The advertiser can track everything on a daily basis relevant statistics on visitors to your website and on individual customers product or service, and at any moment he knows whether an individual investment is worth it and in accordance with that, it is possible to terminate campaigns that do not achieve in time satisfactory return. With all that, digital marketing can reach globally, the possibility of constant advertising - 24 hours a day, 7 days a week and constant improvement through new trends. It has the advantage of mass customization of products to clients (different products and messages to different stakeholders) and has an advantage personalization.

Also, e-marketing reduces costs - cheap distribution communication messages (for example e-mails) and cheap distribution channels for digital products. It is currently the most effective form of advertising in the world. Benefit from of digital marketing are immeasurable: from achieving interaction on a large number contacts between the consumer and the brand to a better understanding and satisfaction of needs customers by their location, the device they use or the time of day they are most open for advertising messages. One of the biggest advantages of digital marketing is that it can be done all activities can be monitored and measured.

Mobile marketing enables simple and fast two-way communication between the brand and the consumer at any time of the day and from any place, because it's mobile phones are highly personalized devices that are completely tailored to the needs and habits of its users. The mobile phone is always with its owner, wherever he is. Mobile marketing provides great opportunities for targeted advertising according to demographic data, locations and consumer habits, and it can be realized through SMS, MMS, creating mobile applications, developing mobile websites, by delivering mobile coupons and the like.

There is also advertising according to the user's location, the full name of which is "location-based advertising" or LBAF. It is a form of direct marketing that integrates mobile advertising with location-based services. Using technology, locating is done consumers to be shown location-specific ads on their mobile phones. On the therefore, advertisers are able to locate consumers who are near them point of sale and provide them with a relevant and up-to-date commercial offer.

The advantages of digital marketing in the sphere of the real estate market are already enormous today, with the fact that these advantages will only grow even more in parallel with the improvement of information and communication technologies and virtual reality.

### **3. DIGITAL MARKETING STRATEGIES IN THE INTERACTION OF MARKET SUPPLY AND DEMAND**

There are many digital marketing strategies that companies use to reach their customers and ultimately develop relationships with them. Some of the most important strategies that will be discussed in the following chapters are: content

marketing, conceptual advertising, website analysis, marketing strategy in relation to the product, marketing strategy in relation to the target market, and marketing strategy in relation to the media of advertising and communication.

Apart from the mentioned strategies, there are many more strategies that companies use in their marketing, and these are often strategies adapted for that particular company, just as every other strategy must be adapted to the needs of each individual company. The goal of marketing strategies is for companies to implement marketing activities as quickly and as simply as possible, which will help achieve the goals of the company. That is why it is important to know well which strategies exist, what their benefits are and how to implement them, which follows below.

**Content Marketing** – As a young marketing strategy, content marketing has not yet developed a concrete definition. It is a strategy that has only just begun to be recognized and used in marketing, and it will take time when different experts and authors begin to come up with concrete definitions for content marketing. Until then, content marketing can be described as a digital marketing strategy that tries to reach customers and create relationships with them through different, impactful, interesting and often useful texts. In English it is called content marketing, while in Serbian there is still no correct, generally accepted word, but it is most often called content marketing or content marketing. Nowadays, many marketing agencies also provide the service of content marketing, which is becoming more and more popular over time and is in great development. On its website, the marketing company defines content marketing as an ideal strategy that demonstrates the professionalism of the business to existing and potential clients, and thus also provides confidence in the purchase of products/services offered by that company.

Content marketing services include the creation of creative new content, as well as the optimization of existing content. Content marketing is not only used on web pages as it is usually linked, but also through social networks, e-mail marketing and advertisements. This marketing agency also states that the importance of this strategy lies in teaching clients about the services, products and ways in which the company operates, which builds trust and creates quality and long-term relationships with customers. Although blogs are quite outdated because they have been overtaken by social networks, there are still people who like to follow a good blog, so some companies have a blog within their websites where consumers can read interesting and useful content that may encourage them to buy, and along the way they can and participate in the communication itself. Then there are long-form contents that are mostly in the form of guides that provide more useful information and instructions about the product/service that the company offers, which is a big advantage for that company.

Furthermore, e-books in general have become very popular in the last few years because they provide simplicity and are a cheaper choice for people who like to read a lot. In the case of e-books for content marketing purposes, they are like manuals of up to thirty pages, and are most useful for more complicated products and services that require more instructions and information.

**Contextual advertising** - Internet search engines have become the main tool for consumers to locate information, which is why Search Engine Marketing (SEM) was born and developed, which includes paid or sponsored search. [7]

In other words, companies pay to be more visible on the first pages of Internet search engines. Search Engine Marketing (SEM), i.e. contextual advertising, refers to advertising on search engines. On the most famous search engine - Google, this method is called Google AdWords. This platform is the largest advertising platform used in digital marketing and through it the most online purchases are made in the world. [8] Therefore, for consumers, the Internet has become the main way to information, which is why Internet pages are filled with various information and content. This led to the development of a tool that makes it easier for companies to stand out from others - SEM, and Google accordingly developed Google AdWords. Google, as the most famous internet search engine in the world, has developed the Google AdWords tool, and its advantages for web traders are as follows [8]:

1. Ads are targeted and timely,
2. you choose the keywords yourself,
3. you don't pay to display ads on Google,
4. you can see every click and every sale,
5. you can optimize each Google Ad Words campaign yourself

This is one of the main strategies and tools that today's modern companies use in digital marketing, considering that it makes it much easier for consumers to search, but also for companies to get customers to their websites. This strategy leads to the next chapter, which is about website analysis itself, and these two strategies are interrelated since they both involve company websites. Website Analysis - When a company creates and maintains a website, it incurs high costs for its creation and maintenance because it requires continuous maintenance, changes and adjustments. For this reason, it is important to analyze its effectiveness so that the company can see if the website serves them, or if it is just an unnecessary expense. This is important information because today there is a lot of competition on the market in almost all branches, which is why it is not enough to just have a good product or service, but the market requires much more effort and investment in order for consumers to recognize companies, their products and services.

Marketing strategy in relation to the product - In order to be able to talk about marketing strategies in relation to the product, it is first necessary to connect it with the growth strategy because the goal of all marketing is the growth of product/service sales, the growth of the brand and popularity, and ultimately the growth company income. Often, the quality of the product alone does not guarantee the success of that product on the market, mainly because of the great competition nowadays, but good marketing strategies can position it high on the market. For this reason, there is a great connection between marketing and the product itself, because marketing would not exist without the need to advertise the product, nor would the product survive on the market without good marketing, and they are closely related to each other.

Marketing strategy in relation to the target market - The market that the company targets depends primarily on the products and services it offers because different cultures, religions, customs, financial capabilities of consumers, different wants and needs are found in different markets, but it also depends on the competition. , that is, market saturation with those specific products or services. Therefore, marketing activities and strategies must be adapted to the market in which they appear, that is, they must choose carefully which market they will try to enter. In fact, we can talk

about target marketing here because the target market is part of the tasks of target marketing.

Transferred to the field of architecture and construction, this would mean that you should first start from the assessment of marketing plans and goals, and then propose a marketing plan and strategy that will breathe new energy into the business. This implies collection, processing and analysis of internal and external information about the company, competitors, customers and clients, search terms and keywords related to this activity. Based on this data, the promotion and marketing campaign is accessed. The marketing presentation about the construction industry and the brand should be created in an informative, technically correct and reliable, useful, relevant and interesting way. All benefits and advantages should be emphasized in order to attract the target public and establish interaction with increased brand awareness with the intention of finding potential clients. Today, it is understood that all the content that is created must be in accordance with Search engine optimization (SEO) guidelines and rules, and the quality of the publication content should be in the center of attention. Construction public relations (PR) is the best tactic for producing and distributing content to the right customers at the right time. Content is distributed through media, social networks, e-mail, and paid advertising. The results of each channel should be measured separately in order to optimize the continuation of the campaign. It is necessary to cover channels such as: media (specialized and general information portals), Google (PPC), social networks, e-mail campaigns, with constant monitoring and regular reporting on the course of the campaign.

#### **4. DEMAND ON THE REAL ESTATE MARKET**

The real estate market is fluid, showing a significant growth trend in recent years. Demand was far greater than supply, and mortgage interest rates were at record lows for a long time. In Serbia, the real estate market is worth about 7 billion euros, and when it comes to whether the maximum price per square meter has been reached or if prices will continue to rise, we can expect a drop in prices from the second quarter of this year. [4]

However, experts point out that several factors will affect the movement of real estate prices, the most important of which is the situation with the Ukrainian crisis, inflation, and the movement of interest rates. The war in Ukraine has a much smaller and indirect effect on real estate prices. We have greater pressure on rental prices, which can have a smaller impact on real estate prices as the profitability of rental has increased now, leaving investors with a slightly greater opportunity for earnings. If we compare the causes of the growth of the real estate market in Serbia, Europe and the world, we can conclude that in Europe and America real estate prices began to fall as a reaction to the rise in interest rates, and that this is not yet the case in our country, but it is certainly expected. In Serbia, the purchase of real estate for cash is pronounced, because people are afraid to give cash and try to convert it into fixed capital, which is why real estate prices are still not falling, while credit buyers have begun to postpone purchases. Thus, until now the demand has been far greater than the supply, and interest rates on housing loans have been at a record low level for a long time. This caused real estate prices to rise significantly with such a ratio of supply and demand. But what trends await us in the coming year, since there has



been a lot of talk lately about the calming down of the real estate market and the possible drop in apartment prices next year?

Several factors will influence it, the most important of which are: the situation with the Ukrainian crisis, inflation, as well as the movement of interest rates. Inflation had the greatest impact on the growth of real estate prices in the past few years.

The war in Ukraine has a much smaller and indirect effect on real estate prices. We have greater pressure on rental prices, which can have a smaller impact on real estate prices as the profitability of rental has increased now, leaving investors with a slightly greater opportunity for earnings. The announced increase in interest rates will certainly have a negative impact on the real estate market, and especially on business space, because reduced economic activity is expected in the coming years and there may even be mass layoffs. Already now we have a certain turn and slowdown of the market, caused by new developments in the world, reduced economic activities and a significant increase in interest rates. All these facts speak in favor of the fact that in the coming period there will be a certain stabilization of prices, so it will be much more difficult to sell properties that are far above the market price in a certain micro location, which was not the case in the previous period. Otherwise, so-called condominiums, i.e. closed complexes that provide comfort, are becoming increasingly popular.

#### **4.1. Motivation and consumer perception on the real estate market**

Motivation can be described as a driving force in individuals that encourages them to act. This driving force arises from a state of tension that exists as a result of unfulfilled needs. Individuals consciously and subconsciously strive to reduce this tension, and they do so through behavior that they sense will fulfill their needs and thus relieve them of the pressure they feel. The specific goals that individuals choose and the patterns of action they undertake to achieve the goals of results are individual thinking and learning. Everyone has a self-image (or multiple self-images) as a certain type of person with certain characteristics, habits, possessions, relationships and ways of behaving. Consumers often try to preserve, improve, change, or expand their self-image by buying products or services from stores that they believe match the image(s) they have of themselves, and avoid products and stores that do not. With the increased use of the Internet, "virtual selves" or "virtual personalities" appear. Consumers' experiences with chat rooms sometimes open opportunities to explore new and alternative identities.

Perception is the process by which individuals select, organize and interpret stimuli into a meaningful and coherent picture of the world. Perception has strategic implications for providers since consumers make decisions based on their own perceptions, not on objective reality. The lowest level at which an individual perceives a certain stimulus is the absolute level of that person. The minimal difference that an individual perceives between two stimuli is called the differential threshold or barely perceptible difference. Consumers perceive most stimuli above the level of consciousness; however, weak stimuli can also be perceived below the level of consciousness (subconsciously). Witte et al. (1995) refute the claim that subconscious stimuli influence the consumer's purchase decision.[5] The selection of stimuli from the environment is based on the interaction of the consumer's expectations and motives with the stimulus itself. The principle of selective perception includes the following concepts: selective exposure, selective attention,

perceptual defense and perceptual blocking. [5] People usually perceive those things that they need and want, and block the perception of unnecessary, uncomfortable or painful stimuli. Consumers organize their perceptions into unique units in accordance with the principles of Gestalt psychology, namely: the relationship between the figure and the background, grouping and rounding off the whole. The interpretation of stimuli is highly subjective, and is based on what the consumer expects to see in the light of previous experience, on several convincing explanations that he can imagine, on motives and interests during perception, and on the clarity of the stimulus itself. Consumers often evaluate the quality of a product or service based on a range of information; some are intrinsic to the product (color, size, taste, aroma) and others are extrinsic (price, image, stores, brand image, ambience in which the service is provided). In the absence of direct experience or other information, consumers often rely on price as an indicator of quality. How the consumer perceives the price - as high, low or fair - has a strong influence on the purchase intention and satisfaction with the purchase. Consumers' ideas are not limited only to the perception of the price and image of the store, but also extend to the manufacturer himself. Manufacturers who enjoy a good image find that their new products are more readily accepted by consumers than those from manufacturers with a less favorable or even "neutral" image. [6]

## **5. THE IMPORTANCE OF DIGITAL MARKETING IN ARCHITECTURE AND CONSTRUCTION**

Digital marketing in construction offers an incredible opportunity - direct connection with target clients or customers. With the right strategy, using various digital channels, it can reach potential clients. Digital marketing improves company visibility. Google is today what the yellow pages used to be. People search the Internet to find construction services and products, so a business must be visible where potential clients are. It is especially important that digital marketing enables precise targeting of the audience. For example, people who live in certain city and surroundings or those who are looking for certain services in the construction industry are targeted. This results in more orders or purchases as it allows to reach a larger number of truly interested customers. Next, an important feature is measurability. Marketing in construction has long relied on traditional methods such as billboard advertising, how many people notice what is presented on a billboard? Digital marketing in construction allows monitoring the performance of marketing campaigns and analysing the results. This means it provides feedback on what works and what doesn't with the ability to adjust strategy accordingly. Also, it allows to monitor Return on Investment (ROI) or return on investment - that is, how much money is received in relation to the money invested in digital marketing. Digital marketing makes it possible to create a long-lasting relationship with clients and customers. Through email marketing, social networks and other digital channels, contacts with clients and customers are maintained even after the job is done. This leads to client and customer loyalty and referrals to others.

Online presence means a good website and social media profiles. A company's website is a kind of modern digital business card that potential clients will see when

looking for your construction services or products. Today, people decide after a few seconds whether they like something or not, so it is important to make a good first impression. The site should be functional, viewable and clear. That people can find their way around it easily, that they know immediately what it is about and how they can place an order or contact the company. The site must be optimized for search engines in order to be seen and visited by more people.

Search Engine Optimization (SEO) is the optimization of web pages for search engines, i.e. positioning the company's website in the best possible place (on the first page) of Google. This means standing out in search for relevant keywords in the construction industry that have to do with that industry. Content is the core of digital strategy. Quality content allows you to demonstrate expertise and knowledge in the construction industry, attract new clients and build client loyalty. The content should educate and inform the audience about various aspects of the construction industry, including trends, technology, processes and projects. This means creating blogs, articles, infographics, video material, which depends on the audience and the strategy itself. Digital marketing in construction is largely based on the use of social networks. They serve to connect with the target audience, provide support and increase loyalty. Social media profiles help build a brand, but it's important to choose platforms that are relevant to the construction industry and target audience.

Paid advertising allows you to target potential customers through paid ads on search engines or social networks. It requires investment, but also a well-thought-out strategy of targeting people in order to achieve good results. In this way, the ads reach the target group and there are greater chances of new visitors to the site, and thus new customers. Paid advertising includes Pay-Per-Click (PPC) ads - payment when someone clicks on the ad. With paid advertising, it is possible to know the exact number of those who were reached by the ad and who were interested in seeing what it was about.

Digital marketing in construction includes advertising and publishing content on specialized portals. The reason is that such portals are visited by the target audience, which is a construction company or a company operating in the field of construction. Everything people need from construction can be found there in one place - information about companies, news and current events, to learn more about a product or service. Digital marketing in construction, i.e. advertising and publication of content on specialized portals, can be done through banner ads, video materials, promotional, or public relations (PR) and native texts. Banner ads are static or animated banners that can be of different dimensions and in different positions on the portal. Promotional texts are sponsored by advertisers, while native texts are also sponsored but look more like an integral part of the portal's content.

## **6. CONCLUSION**

The development of digital marketing has led to the need to adapt marketing activities, but also to different expectations from marketing. Given that digital marketing has the possibility of direct communication between companies and consumers, the marketing relationship began to develop, and at the same time, content marketing. In this way, the relationship between the company and the consumer is built. potential consumers interested in an interactive relationship, want as many opportunities as possible, information via the Internet. It is necessary to

reach the consumer as much as possible, to see what his needs and desires are, and in this way to provide him with what he is currently looking for. An interactive relationship between consumers and providers would establish simple communication, where everyone would be approached individually in such a way that the producer is open to suggestions, advice, doubts and problems.

Marketing in construction and architecture has changed. Designers, investors, traders, contractors are primarily informed on the Internet. The consumer would feel satisfied, and the manufacturer could influence his final purchase decision at any time. The website prototype together with the research is proof that the market needs more of these or similar types of interactive relationship offerings. It is important to have as accessible communication as possible, visibility of the website, various activities on social networks.

Feedback, experiences from others are important to consumers, such promotional messages need to be emphasized, highlighted, as well as any other qualities related to the product. In today's time, where the fast-paced lifestyle has become normal, an interactive website with as much necessary information as possible would save time and money for every consumer.

Construction companies need to understand what digital marketing means and what they gain from it. That it should be an investment in the future where concrete benefits can be seen almost immediately. It all boils down to how to reach as many potential customers as possible, but also how to make it as easy as possible for them to come and become customers. And in this industry, a quality product or service is key, but they can't sell themselves.

Every step on the road to sales is important. From the customer's first encounter with the company's website, navigating it, the ease with which the product can be ordered, but also what others are saying about it and how to behave after the purchase is completed. All of this implies tactics that can also be applied in construction. Companies that use digital marketing are already at an advantage and one step ahead of their competition.

## REFERENCES

- [1] Stošić Mihajlović, Ljilijana: **Linkages marketing and trade**. *Journal of Process Management and New Technologies*, vol. 2, br. 2, str. 45-53, 2017
- [2] Krstić Nataša: **Digitalni marketing – pojmovnik**. *Univerzitet Singidunum, Beograd*, 2015
- [3] Schiffman Leon, Lazar Kanuk Leslie: **Ponašanje potrošača**. *Mate*, Zagreb, 2004.
- [4] Andrić Jelena: Šta nas čeka na tržištu nekretnina 2023? Dostupno na: <https://bizlife.rs/sta-nas-ceka-na-trzistu-nekretnina-u-2023-i-mozemo-li-se-nadati-padu-cena/> (Pristup: 09.04.2023.)
- [5] Lovrić Ivana: **Digitalni marketing u stvaranju interaktivnog odnosa ponude i tražnje**. *Univerzitet u Zagrebu*, 2020.
- [6] Kalra Ajay, Goodstein Ronald: **The Impact of Advertising**. *Journal of Marketing Research* 35, 210-224, 1998.
- [7] Abou Nabout Nadia: **Return on Quality Improvements in Search Engine Marketing**. *Journal of Interactive Marketing* 26(3), 2011.
- [8] Lukinec Mario: **Strategija digitalnog marketinga u poslovnom okruženju**. *University North, Varaždin*, 2019.

# CONSTRUCTION AND DEMOLITION WASTE MANAGEMENT IN SERBIA

Ivan Stojković<sup>1</sup>, Predrag Stanković<sup>2</sup>, Milica Trpkova<sup>3</sup>

## Abstract

*The construction industry in Serbia has led to an increase in construction and demolition waste (CDW), which represents a significant challenge in waste management. This paper aims to analyze the existing management of CDW in Serbia and propose a strategy through a case study of constructing a football stadium. Insufficient infrastructure for waste storage and treatment, and limited awareness of recycling, hinder the effective management of CDW despite existing legal obligations. The "Waste Management Program in Serbia 2022-2031" foresees an increase in the recycling rate from the current 1% to 40% by 2031, but the absence of by-laws makes it challenging to separate and collect waste for recycling. To improve CDW management and achieve recycling targets, comprehensive regulations for source separation, collection, transport logistics, and public education are needed. Improving CDW management will positively impact environmental protection and resource use in Serbia. By implementing mobile waste treatment plants at the regional level, up to 70% of recyclable materials can be recovered, while the remaining 30% can cover landfills and rehabilitate threatened areas. The case study in this paper provides an overview of CDW quantities and management following legal regulations. From this Case Study, it can be concluded that it is necessary to build mobile facilities and centers for recycling construction waste, which will increase the recycling rate and reduce the percentage of deposited CDW.*

**Keywords:** waste management, circular economy, recycling, mechanical treatment

---

<sup>1</sup> Innovation Center, Faculty of Technology and Metallurgy, Belgrade, Serbia

<sup>2</sup> Stanković - inženjering d.o.o., Leskovac, Serbia

<sup>3</sup> Faculty of Civil Engineering and Architecture, University of Niš, Serbia (PhD student)

## **1. INTRODUCTION**

Urbanization drives increased construction and demolition, generating substantial waste that requires effective management practices. Construction and demolition waste (CDW) in Serbia and globally presents significant environmental and economic challenges. This study assesses CDW management in Serbia, identifies key challenges, and proposes sustainable waste management strategies. The research includes an analysis of literature, legislative frameworks, and case studies.

The primary goal of CDW management is to minimize waste generation and ensure proper disposal, reducing environmental impacts. Many countries have implemented strict regulations to address CDW as an environmental concern. In Serbia, CDW management is incorporated into the 2022-2031 Waste Management Program as stipulated by the "Official Gazette of RS" in December 2022. This program provides a comprehensive framework and guidelines for sustainable waste management, aiming to enhance capabilities and contribute to a cleaner, more sustainable environment.

From the results of the case study analysis, it can be concluded that Serbia lacks by-laws for the full implementation of legal regulations. Also, to increase the percentage of recycling of CDW, it is necessary to build recycling centers with mobile facilities.

## **2. RESEARCH OBJECTIVES AND METHODOLOGY**

This study analyzes the legal regulation of construction and demolition waste management (CDW) in Serbia. It briefly overviews the country's waste management framework and legal aspects. The case study aims to assess the current management of construction and demolition waste in Serbia, specifically focusing on the Facility Removal Project and its implementation at the local level.

## **3. CONSTRUCTION AND DEMOLITION WASTE (CDW)**

### **3.1. Definition, composition, and division of CDW**

According to the Law on Waste Management ("Official Gazette of RS," 36/2009, 88/2010, 14/2016, 95/2018 - other laws and 35/2023), waste is any discarded substance or object. The law categorizes waste into communal, commercial, and industrial types. Waste can be classified as inert, non-dangerous, or dangerous based on its hazardous characteristics. CDW is waste generated from construction and demolition activities, including building works, renovations, infrastructure maintenance, and excavations. CDW can be non-hazardous (recyclable, inert, etc.) or hazardous waste that requires special treatment due to dangerous characteristics like asbestos or high heavy metal content, regulated by specific rules [1]. These products were extensively used in construction for insulation and roofing, and their presence during building demolition or reconstruction poses health risks to humans [2].

Construction waste is classified in the Waste Catalog as group 17. Non-hazardous construction and demolition waste includes concrete, soil, brick,

glass, stone, plastic, tile, ceramics, copper, bronze, brass, iron, steel, insulation, gypsum, wood, and mixed waste. Hazardous waste from construction and demolition encompasses materials containing asbestos, PCB-containing sealants and glazes, mercury-containing waste, and other waste-containing hazardous substances. In terms of composition, construction and demolition waste in Serbia is estimated to consist of 75% excavated soil, 15-25% construction and demolition waste (ceramics, concrete, iron, steel, plastic waste), and 5-10% waste asphalt and concrete [3]. CDW combines inert and non-inert materials resulting from various construction-related activities such as construction, excavation, reconstruction, demolition, and road works. Inert materials include soil, earth, silt, rock, and crushed concrete, while non-inert materials encompass metal, wood, plastic, and packaging waste [4].

Recycling of construction and demolition waste relies on source separation to be effective, as the collection of mixed waste increases pollution and hampers recycling opportunities. Unfortunately, available statistics do not provide the potential for construction and demolition waste management (CDW) in Serbia. In 2020, Serbia generated 729,000 tons of CDW, significantly higher than EU countries [5]. However, in Serbia, there is currently no practice of a separate collection or recycling scheme for CDW. Only small amounts are recycled, with minimal asphalt recycling (less than 1,000 tons in 2018). The absence of a by-law hampers the enforcement of waste sorting obligations, leading to valuable materials like metal being recycled while others end up in landfills or illegal locations. Quality standards for treated CDW are also lacking [3].

Construction waste can be categorized based on its generation type:

- Waste from complete or partial building demolition,
- Waste generated during the construction of new buildings,
- Waste resulting from road construction and maintenance,
- Removal of soil, stones, and vegetation for site preparation.

The composition of construction waste varies depending on the construction project, its purpose, and whether it involves building, demolition, or reconstruction. Common materials in high-rise construction include concrete, brick, plaster, lightweight concrete, and natural stone. Excavation activities produce soil, sand, gravel, stone, loam, and clay waste. Civil engineering projects generate construction waste like bitumen (asphalt), cement-bound material, sand, gravel, and crushed stone. Construction activities also produce mixed waste comprising wood, plastic, metal, and cables.

Construction waste is smaller in volume compared to demolition waste but often has higher usability. If the excavated material is used on-site, it is not considered construction waste but a mineral raw material.

### **3.2. Categorization, examination, and classification of waste**

Waste is classified based on the Waste Catalog, a comprehensive list of non-hazardous and hazardous waste categorized by origin and composition. In the Republic of Serbia, the Rulebook on waste categories, testing, and classification ("Official Gazette of RS," 56/2010, 93/2019, and 39/2021) provides guidelines for waste classification, including the catalog of waste, lists of waste categories (Q list), hazardous waste categories (Y list), waste components that make it hazardous (C list), hazardous characteristics of waste (H list), procedures and methods of waste

disposal and reuse (D and R list), concentration limit values for determining waste characteristics, parameters for physicochemical treatment and thermal treatment, waste testing parameters, and reporting requirements for waste testing and classification. The categorization process involves considering the waste's nature, origin, place of origin, composition, and concentration of hazardous substances, following the guidelines in the Waste Catalog.

The Law on Waste Management requires a thorough waste description for safe handling and management. Documentation, including the waste index number, must accompany any change of ownership. It is essential to identify and understand all important characteristics of the waste for proper handling. This information enables owners in the waste management chain to comply with environmental and health regulations, such as permits and pollution source registers.

Waste is classified according to the Waste Catalog, which aligns with the European Waste Catalog. The catalog systematizes over 800 types of waste into 20 groups and corresponding subgroups marked with two-digit and four-digit numbers, respectively. Each waste type is uniquely identified by a six-digit index number in the catalog, covering both hazardous and non-hazardous waste.

To select the correct index number from the Waste Catalog, consider the following criteria:

- The activity of waste generation
- Method or process involved in waste generation
- Waste description and composition
- Presence of hazardous substances and associated hazards

In the Waste Catalog, two-digit index numbers represent groups or activities, while four-digit index numbers indicate subgroups or specific processes. The six-digit index number provides precise waste identification. Always choose the index number that accurately describes the waste, considering the group, subgroup, and classification procedure. Sometimes, selecting an index number outside the named group or subgroup may be necessary if it provides a more precise and accurate description. Ensure proper waste management by describing waste appropriately to enable safe handling. If in doubt, gather additional data or provide a detailed waste description. Accurately determining index numbers is crucial for effective waste management and minimizing environmental and health impacts.

Construction waste is categorized as number 17, covering both wastes from construction and demolition activities, including contaminated soil. Subgroups of waste are identified by four-digit numbers, such as 17 01 for concrete, bricks, tiles, and ceramics. The six-digit numbers specify specific types of waste, such as 17 01 01 for concrete. It is crucial to note the six-digit numbers marked with an asterisk, as they indicate hazardous waste [6].

### **3.3. The impact of CDW on the environment**

Illegal dumping sites pose significant environmental hazards, contaminating soil, air, and water and posing a risk to human health and wildlife. Often filled with household waste, construction debris, and even hazardous materials, these sites are prone to fires, releasing toxic smoke and endangering surrounding vegetation. Hazardous substances like asbestos and chemical packaging can leach into the soil and water, particularly affecting areas without proper water supply systems. The disposal of construction waste is challenging due to



hazardous materials such as asbestos, heavy metals, and volatile organic compounds impacting human health and the environment. The increasing volume of construction waste globally has become a pressing environmental and economic concern, necessitating effective waste management practices to mitigate its effects [7].

### 3.4. CDW management in Serbia

In Serbia, the Ministry of Environmental Protection oversees the management of demolition waste in accordance with legislation. CDW is separated at the site for treatment or reuse, and records must be kept by those handling this waste. Uncontrolled dumping is prohibited. Waste management in Serbia is guided by principles such as environmental optimization, self-sufficiency, proximity and regional approach, waste hierarchy, responsibility, and the "polluter pays" principle. Construction waste management involves reducing waste, promoting reuse, separate collection, recycling, energy recovery, and proper disposal [1].

Construction and demolition waste in Serbia makes up more than 75 % of the total garbage. Three to four million tons of waste are produced annually in our country, 300 to 700 thousand tons in Belgrade. The only legal landfill where construction waste can be disposed of is Vinča. However, it only accommodates a third of that material [8].

The Republic of Serbia's Waste Management Program aims to increase construction waste recycling from the current 1% to a projected 40%. However, the lack of by-laws hinders the enforcement of the obligation to separate waste. The polluter pays principle holds waste producers responsible for legal and safe disposal. Currently, mineral and mixed construction waste mostly end up in inadequate local landfills, while only metal waste is collected on a larger scale. Separation of hazardous and non-hazardous waste is insufficiently practiced, including during demolition and reconstruction, where minimal amounts of recyclable and hazardous components are separated.

The investor holds responsibility for managing waste in demolition and reconstruction activities. The waste owner should organize the waste collection through contracts with permitted waste management companies. A specific regulation is needed to manage this waste stream. Asbestos-containing waste removal is supervised by labor inspection, following occupational safety laws. Asbestos has been banned in the EU since 2005, but it can still be found in construction waste and various products. Waste containing asbestos must be separated at the source and transported in appropriate packaging for disposal in authorized landfills. Recycling or reuse of asbestos is prohibited [3], [9], [10].

This paper presents a case study of constructing a football stadium in Leskovac. The general state of construction waste management in the city of Leskovac is characterized by the following:

- a temporary location for the disposal of construction waste exists, but it is unorganized;
- construction waste is also disposed of in illegal landfills;
- there is no system of separate collection and treatment of construction waste;
- there is no system for separating hazardous construction waste (asbestos) before the start of demolition;

- the recycling of construction waste and the use of recycled material have not been developed, so large amounts of construction waste are disposed of in an uncontrolled manner;
- there was no education on construction waste management;
- there is no Construction Waste Management Project for the city territory [11].

From the reviewed regulations, it can be concluded that the current state of construction waste management in RS is unsatisfactory:

The legislative framework has not been established.

Only waste with asbestos is regulated.

The regulations do not define the exact status of recycled waste.

There are no binding targets for recycling.

There are no landfills for construction waste. Lack of infrastructure for waste treatment.

### **3.5. CDW management in the world**

CDW creation and management are influenced by several factors, including population, urbanization, gross domestic product (GDP), and CDW management regulatory measures [12]. The amount of waste generated in construction and demolition (CDW) processes is enormous. Construction waste is mainly caused by improper design, poor procurement and planning, inefficient material handling, leftover raw materials, and unexpected changes in building design [13].

Concerning CDW management, data from 40 countries from 6 continents were analyzed with a focus on the generation of construction waste and demolition waste following state policies. Waste production has continuously grown, reaching over 3.0 billion tons annually by 2012. [14]

Construction waste is a key challenge, especially in urban areas such as China, the US, and the EU.

The construction sector in Europe generates the most waste. The EU is trying to move from a linear to a circular resource and waste management model. The new "waste hierarchy" paradigm is part of the EU Framework Directive. The paper analyzes the construction and demolition waste management in Europe, following the evolution of the waste hierarchy and innovative methods of waste concrete treatment. Globally, the linear economic model generates enormous amounts of waste and puts pressure on resources. The circular economy promotes reduction, reuse, and recycling. Urbanization is increasing, and a circular approach is vital to sustainable waste management [15].

The United States has a more developed CDW management system. At the same time, China is a growing economy with some management shortcomings in the construction industry. Key proposals for improving CDW include state oversight with access to economic incentives; interaction of interested parties; mutual coordination between operational departments; setting up audits and inspections, and continuous development and integration of new technologies [12].

Construction firms in India generate about 1012 million tons of waste annually [16]. The amount of demolition waste is more significant than construction waste. CDW management is a new concern. The absence of regulation and enforcement compounds the problem. This paper proposed a solution to the

problem based on the global status of CDW and the hierarchy of sustainable waste management [17].

Countries like China and India must monitor and manage their CDW with government awareness initiatives. Recycled aggregates are often of lower quality; adding other materials to improve their characteristics is recommended. It is suggested to use recycled aggregates in the range of 30% to 50% to achieve the strength of natural concrete with additional cementitious materials. Further research is needed to expand the use of these materials in the construction industry and develop standards for their application [14].

On average, around 50,000 tons of construction and demolition waste are produced in Tehran per day, of which over 30,000 tons are disposed of in landfills. According to this research, more than 57% of this waste falls into the first category (non-hazardous waste) and has the potential for recycling and reuse. On the other hand, waste classified in the second category will be managed based on existing laws [18].

Daniel R. Rondinel-Oviedo conducted research based on 265 surveys, interviews, and visits to construction sites and landfills in Peru. The data was analyzed concerning various aspects such as the manager's education, location, building dimensions, usage, etc. The analysis results provide information for better decision-making on CDW management, environmental impact reduction, and economic benefits, especially in developing countries [19].

Building Information Modeling (BIM) manages CDW effectively, solving design and process problems. This paper explores the potential of BIM technology to support building design and construction processes for CDW management. Building Information Modeling (BIM) manages CDW effectively, solving design and process problems. This paper explores the potential of BIM technology to support building design and construction processes for CDW management. Specifically, this paper proposes BIM-based approaches to reduce, reuse, recycle, and manage construction waste through deviation detection, increased recycling, construction activity planning, site use planning, and prefabrication [13].

#### 4. CASE STUDY

The planned project involves constructing a football stadium in Leskovac. It includes demolishing and removing a gross construction area of 3,230 m<sup>3</sup>, which consists of 13 buildings [20]. The waste generated from the demolition of the existing stadium is listed in Table 1, in accordance with the Rulebook on categories, testing, and classification of waste ("Official Gazette of RS," no. 56/2010, 93/2019, and 39/2021) [6].

Table 1 List of generated waste and total amount after demolition [21]

Index number	Unit	Quantity	CDW
<b>17 01</b>	<b>Concrete, bricks, tiles, and ceramics</b>		
17 01 01	m <sup>3</sup>	1.583	Concrete
17 01 02	m <sup>3</sup>	280	Brick
17 01 03	m <sup>2</sup>	620	Ceramics, tiles

<b>17 02</b>	<b>Wood, glass, and plastic</b>		
17 02 01	m <sup>3</sup>	12	Wood
17 02 02	m <sup>2</sup>	800	Glass
17 02 03	kg	250	Plastic
<b>17 03</b>	<b>Bituminous mixtures, tar, and tar products</b>		
17 03 02	m <sup>2</sup>	400	Bituminous mixtures other than those specified in 17 03 01
<b>17 04</b>	<b>Metals (including their alloys) 17 04</b>		
17 04 02	kg	500	Aluminum
17 04 05	kg	155.000	Iron and steel
<b>17 05</b>	<b>Earth (including earth excavated from contaminated sites), rock, and excavation</b>		
17 05 04	m <sup>3</sup>	8.300	Earth and stone other than those mentioned in 17 05 03
<b>17 06</b>	<b>Insulation materials and building materials containing asbestos</b>		
17 06 04	m <sup>2</sup>	200	Insulating materials other than those mentioned in 17 06 01 and 17 06 03
<b>17 08</b>	<b>Construction material based on gypsum</b>		
17 08 02	m <sup>3</sup>	20	Gypsum-based building materials other than those specified in 17 08 01
<b>17 09</b>	<b>Other construction and demolition waste</b>		
-	-	-	-

After the final selection, the waste was placed in bags or containers, which prevented spillage. As the owner of the waste, the producer sorted it according to regulations. The waste was stored until it was handed over to authorized collectors, transporters, or storage facilities with a contract and a valid permit from the Ministry of Environmental Protection. There is supporting documentation for waste transport, but it was unavailable when writing.

No information is available on packaging waste used as secondary raw material. Based on the data from the table, there was no hazardous waste.

The waste was stored at the manufacturer's location in technically equipped facilities with minimal impact on human health and the environment. The waste storage of secondary raw materials was in the open, fenced, and under surveillance. Different waste fractions, such as concrete, plaster, tiles, wood, and glass, were collected separately and handed to authorized operators or construction waste dumps. Excavated soil was collected in piles, used to fill the surrounding soil, or transported to municipal waste landfills for covering. The scrap metal was handed over to authorized operators. Standard containers for municipal waste were placed on the construction site.

## **5. DISCUSSION AND PROPOSAL FOR IMPROVEMENT OF CDW MANAGEMENT**

From the presented case study, it can be concluded that the CDW management was by the existing legal regulations, but that the data for the

quantities of certain types of waste were not transparent. Of the total amount of CDW, only the metal was handed over for recycling, while the rest of the waste was deposited. Landfilling, as the most unfavorable operation in the waste management hierarchy, is a direct consequence of the lack of infrastructure for recycling. Management by the global waste management hierarchy (5R rule) can be proposed as a possibility to reduce the deposited CDW. Hierarchy of waste management (5R):

- Waste prevention and resource reduction,
- Reuse of products,
- Recycling for raw material production,
- Recovery for energy generation, and
- Environmentally responsible disposal.

Use procedures are labeled with R, and disposal procedures with D. The preferred options in the construction waste management hierarchy (Figure 1) are waste utilization activities such as energy recovery (R1), metal recycling (R4), and recycling of other inorganic materials (R5) [5].

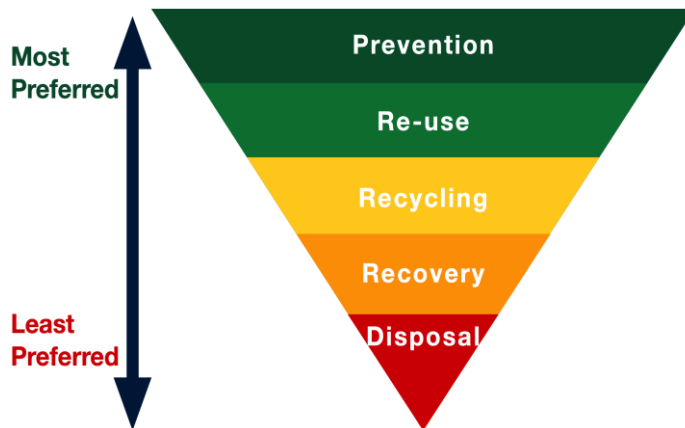


Figure 1. Hierarchy of waste management

<https://ismwaste.co.uk/help/what-is-the-waste-hierarchy> [22]

To achieve the goal from the Program 2022-2031, it is necessary to build mobile and stationary plants and several locations to dispose of excavated soil. The capacities of the facilities must follow the estimated amount of waste in the territory where the construction of such facilities is planned.

The locations of recycling yards, where mobile plants would be, must comply with strictly established criteria.

The implementation of the 2022-2031 Program implies the change of many regulations and the adoption of new European standards. Also, construction companies must be informed to be ready to enter these jobs [8].

Buildings must be designed, built, and removed in such a way that the use of natural resources is sustainable and is specifically guaranteed:

- (a) the reuse or recycling of the building, its materials, and parts after removal;
- (b) the durability of the building;

(c) use of ecological raw materials and secondary materials in building construction [23].

Key steps for improving the management of construction waste and demolition waste in Serbia:

1. Project preparation: Building Information Modeling (BIM) and using modular elements that can be reused and easily recycled. Develop a demolition waste management project, including plans for sorting, collection, transportation, treatment, and disposal.

2. Sorting of waste: Sorting waste at the point of origin according to the type of material (concrete, brick, wood, metal) to separate recyclables from those that cannot be recycled.

3. Collection and transport of waste: Collection and transport of sorted waste to appropriate locations using specialized containers or trucks.

4. Waste treatment: Applying treatment procedures to reduce the amount of waste or improve recyclability, such as crushing concrete for reuse as a construction material.

5. Waste disposal: Waste disposal at registered construction waste landfills that meet environmental standards.

## **6. CONCLUSION**

Serbia can effectively manage CDW, reduce environmental impact, and promote sustainability by addressing these issues and aligning with the Waste Management Program. It is necessary to draft by-laws to establish an effective waste management system. These by-laws should focus on reducing waste generation, managing hazardous waste characteristics, implementing waste separation and collection at the source, establishing logistics units for waste collection, organizing waste treatment, ensuring quality management, and providing population training. Controlling the separation of construction and demolition waste at the source allows for accurate data on waste types, quantities, and flows, facilitating the obtainment of high-quality materials for recycling. Additionally, separating hazardous from non-hazardous waste at the source prevents environmental pollution. A system of sites with mobile facilities for construction waste treatment should be established to achieve these goals. This system would ensure proper waste storage after treatment in an economically viable manner at the regional level. Drafting these by-laws is crucial to increase construction waste recycling and fulfilling the objectives outlined in the Waste Management Program.

## **ACKNOWLEDGMENTS**

The Republic of Serbia – Ministry of Science, Technological Development and Innovation, Program for Financing Scientific Research Work, 451-03-47/2023-01/200287.

## REFERENCES

- [1] **Zakon o upravljanju otpadom** ("Sl. glasnik RS", br. 36/2009, 88/2010, 14/2016, 95/2018 - dr. zakon i 35/2023);
- [2] Cerovec Ivan: **Upravljanje građevinskim otpadom**. *Undergraduate thesis, University of Zagreb, Faculty of Geotechnical Engineering*, 2018. ; Download date: 2023-06-05; <https://urn.nsk.hr/urn:nbn:hr:130:577357>;
- [3] **Program upravljanja otpadom u Republici Srbiji za period 2022-2031**. ("Sl. glasnik RS", br. 12/2022);
- [4] Poon C.S.: **Reducing Construction Waste**. *Waste Management* 27: 1715–1716, 2007.
- [5] **Statistical Yearbook of the Republic of Serbia**, 2021;
- [6] **Pravilnik o kategorijama, ispitivanju i klasifikaciji otpada** ("Sl. glasnik RS", br. 56/2010, 93/2019 i 39/2021);
- [7] Arslan Hakan, Cosgun Nilay, Salgin Burcu: **Construction and Demolition Waste Management in Turkey**. *Additional information is available at the end of the chapter* <http://dx.doi.org/10.5772/46110>;
- [8] <https://energetskiportal.rs/da-li-postoji-trajno-resenje-za-gradjevinski-otpad/>;
- [9] **Pravilnik o uslovima i načinu sakupljanja, transporta, skladištenja i tretmana otpada koji se koristi kao sekundarna sirovina ili za dobijanje energije** ("Sl. glasnik RS", br. 98/2010);
- [10] **Pravilnik o načinu skladištenja, pakovanja i obeležavanja opasnog otpada** ("Sl. glasnik RS", br. 92/2010 i 77/2021);
- [11] **Lokalni plan upravljanja otpadom na teritoriji Grada Leskovca za period 2010. – 2020**. Leskovac, avgust 2009.
- [12] Shahzad Aslam Muhammad, Huang Beijia, Lifeng Cui: **Review of construction and demolition waste management in China and USA**. *Review Journal of environmental management*, 2020.;
- [13] Jack C. P. Cheng, Jongsung Won, Moumita Das: **Construction and Demolition Waste Management Using BIM Technology**, 2015.
- [14] Ali Akhtar, Ajit K. Sarmah: **Construction and demolition waste generation and properties of recycled aggregate concrete**. *Journal of Cleaner Production* 2018.;
- [15] Chunbo Zhang a, Mingming Hu a,b,\*, Francesco Di Maio c, Benjamin Sprecher d, Xining Yang a, Arnold Tukker a,e: **An overview of the waste hierarchy framework for analyzing the circularity in construction and demolition waste management in Europe**. *Science of the Total Environment*, 2021.;
- [16] Rema R.: **Review on the current construction and demolition waste management framework**. 2019.;
- [17] Harish. P. Gayakwad, Neha. B. Sasane: **Construction and Demolition Waste Management in India**. *International Research Journal of Engineering and Technology (IRJET)*, Volume: 02 Issue: 03, 712-715, 2015;
- [18] Broujeni B. R., Omrani G., Naghavi R., Afraseyabi S.: **Construction and Demolition Waste Management**. (Tehran Case Study), 2016.; <https://elicit.org/search>
- [19] Area Daniel R. Rondinel-Oviedo: **Construction and demolition waste management in developing countries: a diagnosis from 265 construction sites in the Lima Metropolitan Area**. *Scientific Research Institute, University of Lima, Lima, Peru*, 2021.;
- [20] Sugaris Đorđe: **Projekat pripremnih radova, Projekat uklanjanja objekta, sveska 10/1, Fudbalski stadion u Leskovcu na KP br. 6669 KO Leskovac, Projektant: CEP-Centar za planiranje urbanog razvoja 11000 Beograd, Zahumska 34**, 2022.;

- [21] Đurović Ognjen: **Plan upravljanja otpadom 12.0, Projekat uklanjanja objekta, Fudbalski stadion u Leskovcu na KP br. 6669 KO Leskovac**, Projektant: CEP-Centar za planiranje urbanog razvoja 11000 Beograd, Zahumska 34.
- [22] <https://ismwaste.co.uk/help/what-is-the-waste-hierarchy>; 4.7.2023. 18:58 h;
- [23] **Regulation (EU) No 305/2011** of the European Parliament and of the Council of 9 March 2011 laying down harmonised conditions for the marketing of construction products and repealing Council Directive 89/106/EEC.



## PREISACH MODEL FOR INNER HYSTERESIS LOOPS OF CYCLICLY LOADED MILD STEEL ELEMENTS

Petar Knežević<sup>1</sup>, Aleksandar Radaković<sup>2</sup>, Nikola Velimirović<sup>3</sup>, Zoran Perović<sup>4</sup>, Nenad Stojković<sup>5</sup>

### Abstract

*In this paper, the new type of Preisach model, that describes the inner hysteresis loops of structural mild steel under cyclic loading, is developed. It is the multilinear mechanical model, that describes closed hysteresis loops typical for structural steel. The analytical model and appropriate Preisach triangle, suitable for engineering practice, were defined. This model was verified by comparison with the experimental results. The experiment has been carried out on structural steel S275 specimens, cyclicly loaded.*

**Key words:** *structural mild steel, cyclic loading, hysteresis loop, Preisach model*

---

<sup>1</sup> Dr Sc., Professor, State University of Novi Pazar, pknezevic@np.ac.rs

<sup>2</sup> Dr Sc., Professor, State University of Novi Pazar, aradakovic@np.ac.rs

<sup>3</sup> Dr Sc., Professor, State University of Novi Pazar, nvelimirovic@np.ac.rs

<sup>4</sup> Dr Sc., Professor, Faculty of Civil Engineering, Belgrade, zperovic@grf.bg.ac.rs

<sup>5</sup> Dr Sc., Professor, College of Applied Technical Science, Niš, nenad.stojkovic@akademijanis.edu.rs

## 1. INTRODUCTION

Hysteretic response of ductile materials subjected to cyclic loading has been long standing topic of research interest. The model today known as Preisach model is first defined by Preisach in 1935 [1] to describe hysteretical phenomena which occur in magnetism. Shortly is found its application in describing the hysteretic response of ductile materials under cyclic loading. The response of rigid materials with linear hardening, elastic perfectly-plastic materials, and elastic materials with linear hardening has been shown via adequate Preisach models in papers [2] and [3]. Preisach model also found application in defining problems such as cyclic bending [4] and damage modeling under cyclic loading [5]. Problems such as material behavior under monotonic loads also are defined [6], where phenomena like yield plateau and damage growth has been explained.

Generally, Preisach model is using hysteretic operator for defining the cyclic behavior of ductile materials. It is a pure mathematical operator [7], which maps input function  $u(t)$  into output function  $f(t)$  in integral form:

$$f(t) = \hat{\Gamma}u(t) = \iint_{\alpha \geq \beta} G_{\alpha,\beta} u(t) \mu(\alpha, \beta) d\alpha d\beta \quad (1)$$

Where  $G_{\alpha,\beta}$  is an elementary hysteresis operator given in Figure 1. Parameters  $\alpha$  and  $\beta$  are up and down switching values of the input, while  $\mu(\alpha, \beta)$  is the Preisach function. Although  $G_{\alpha,\beta}$  operators have a qualitative feature of local memory, the consequence of joining a large (infinite) number of these operators with the same qualitative characteristics is the formation of the Preisach model with the non-local memory.

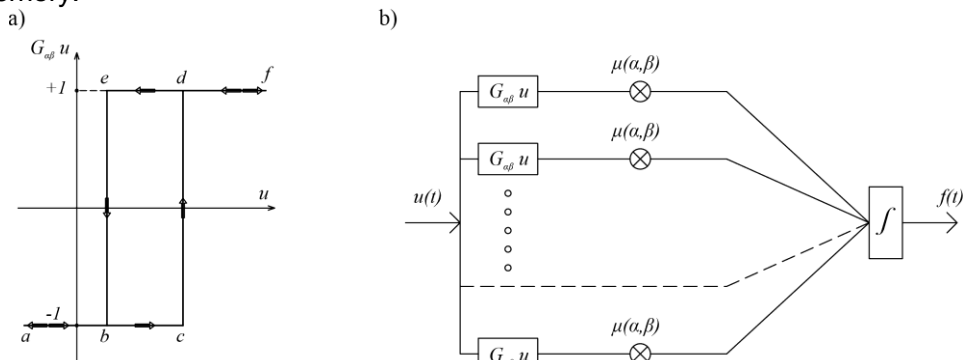


Figure 1- a) Elementary hysteresis operator  $G_{\alpha,\beta}$ ; b) Formation of the final answer in the Preisach model of hysteresis by superposition of elementary hysteresis operators

Existing models are based on bilinear working diagrams and are used for mapping the input function ( $\varepsilon$  or  $\sigma$ ) into the output function ( $\sigma$  or  $\varepsilon$ ). In this paper, more complex model will be used.

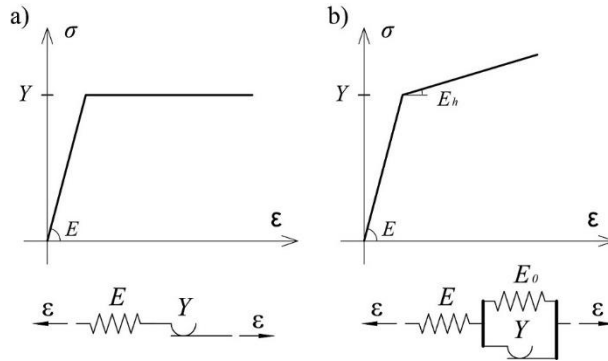


Figure 2 - Working diagrams and mechanical models for: a) ideally elastoplastic material; b) ideally elastoplastic material with hardening

The application of the proposed model is verified by comparison with experimental results obtained by testing cylindrical samples made of one of the most used European structural steel type S275. The first part of the paper represents an introduction to the problem that is analyzed. In the second section of this paper, basic expressions and considerations of the Preisach model for the single crystal under cyclic uniaxial load are shown. In the third section, the polycrystalline model is introduced and finally, verification of the model and comparison with experimental results are presented in section 4.

## 2. SINGLE CRYSTAL PREISACH MODEL FOR INNER HYSTERESIS LOOPS OF CYCLICLY LOADED MILD STEEL ELEMENTS

A new type of Preisach model for response of structural mild steel under constant cyclic loading will be developed in this paper. Its basis is a model that describes the behavior of this type of steel under monotonic loading [7].

The cyclic behavior of the examined steel types is characterized by the formation of regular hysteresis loops, with no yield plateau. A five-element model with a trilinear working diagram, shown in Figure 3, was used in this paper.

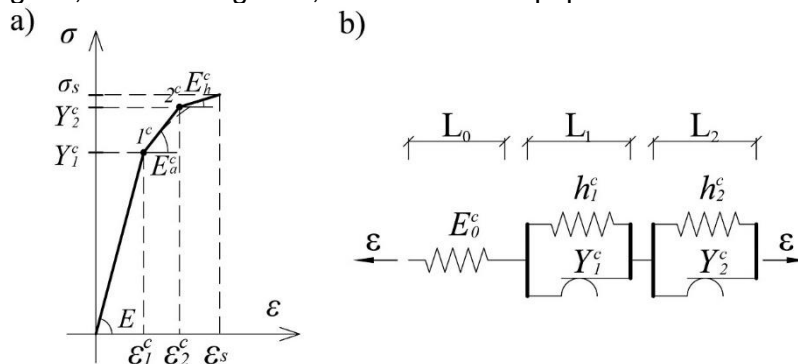


Figure 3. (a) The stress–strain diagram of structural mild steel single crystal under cyclic loading and (b) mechanical single crystal model.

The material properties of the mechanical model, shown in Figure 3b), are defined by Equation (2).

$$\begin{aligned}
 E &= E_0^c(L_0 + L_1 + L_2)/L_0 \\
 E_a &= E_0^c \cdot E_1^c / (E_0^c + E_1^c) \\
 E_1^c &= h_1^c(L_0 + L_1 + L_2)/L_1 \\
 E_h^c &= E_0^c \cdot E_1^c \cdot E_2^c / (E_0^c + E_1^c + E_2^c) \\
 E_2^c &= h_2^c(L_0 + L_1 + L_2)/L_2
 \end{aligned}
 \tag{2}$$

It is possible to define a new hysteresis mechanical model based on the working diagram shown in Figure 3a), with single integrals.

$$\begin{aligned}
 \sigma^c(t) &= \frac{E}{2} \int_{-\varepsilon_s}^{\varepsilon_s} G_{\alpha,\alpha} \varepsilon(t) d\alpha \\
 &+ \frac{E_a^c - E}{2} \int_{2\varepsilon_1^c - \varepsilon_s}^{\varepsilon_s} G_{\alpha,\alpha - 2\varepsilon_1^c} \varepsilon(t) d\alpha \\
 &+ \frac{E_h^c - E_a^c}{2} \int_{2\varepsilon_2^c - \varepsilon_s}^{\varepsilon_s} G_{\alpha,\alpha - 2\varepsilon_2^c} \varepsilon(t) d\alpha
 \end{aligned}
 \tag{3}$$

The first integral of Equation (3) represents the stress due to elastic deformation. The second and third addends describe the behavior of the material after reaching the yield strengths  $Y_1^c$  and  $Y_2^c$ , respectively. The shown solution presents the response of one single crystal due to the cyclic axial load.

### 3. POLYCRYSTALLINE PREISACH MODEL FOR INNER HYSTERESIS LOOPS OF CYCLICLY LOADED MILD STEEL ELEMENTS

According to Iwan [8], a new model represented by a parallel connection of an infinite number of models, where the output of a single model is defined by the expression (3), can be obtained.

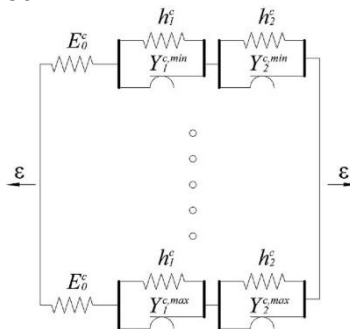


Figure 4 - Parallel connection of infinitely many unit models with different yield limits  $Y_i^{c,min} \leq Y_i^c \leq Y_i^{c,max}$

The parallel connection of the model is possible due to the deformation  $\varepsilon(t)$  as the input. For a system of infinitely parallel connected models (Figure 4) with different yield limits  $Y_i^{c,min} \leq Y_i^c \leq Y_i^{c,max}$ , the expression for the total stress becomes:

$$\sigma(t) = \Sigma \int_{Y_i^{c,min}}^{Y_i^{c,max}} p(Y_i^c) \sigma(Y_i^c, t) dY_i^c
 \tag{4}$$

In the expression (4),  $\sigma(Y_i^c, t)$  represents stress corresponding to the single element of the yield limit  $Y_i^c$ , and  $p(Y_i^c)$  is the distribution function of the yield limit. In this way, the material is defined as a polycrystalline, consisting of crystals with different yield limits  $Y_i^c$ , but of the same Young's modulus  $E$ , and the hardening modulus  $E_a^c$  and  $E_h^c$ . The distribution function of all  $Y_i^c$  values is uniform, as in papers [2]–[4], [6], [9], and [10]:

$$p(Y_i) = \frac{1}{Y_i^{c,max} - Y_i^{c,min}} = const \quad (5)$$

the total stress, due to strain as an input, becomes:  $\sigma^c(t) = \sigma^c(t) =$

$$\begin{aligned} & \frac{E}{2} \left[ \int_{-\varepsilon_s}^{\varepsilon_s} G_{\alpha,\alpha} \varepsilon(t) d\alpha \right. \\ & + \frac{E_a^c - E}{E} p(Y_1^c) \int_{Y_1^{c,min}}^{Y_1^{c,max}} \int_{2\varepsilon_1^c - \varepsilon_s}^{\varepsilon_s} G_{\alpha,\alpha - 2\varepsilon_1^c} \varepsilon(t) d\alpha dY_1^c + \\ & \left. \frac{E_h^c - E_a^c}{E} p(Y_2^c) \int_{Y_2^{c,min}}^{Y_2^{c,max}} \int_{2\varepsilon_2^c - \varepsilon_s}^{\varepsilon_s} G_{\alpha,\alpha - 2\varepsilon_2^c} \varepsilon(t) d\alpha dY_2^c \right] \quad (6) \end{aligned}$$

It can be seen that the first part of the expression (6) does not depend on  $Y_i^c$ , and based on the second and third parts, following equalities hold respectively:  $\alpha - \beta = 2\varepsilon_1^c$ ,  $\alpha - \beta = 2\varepsilon_2^c$ .

Based on expressions (2),  $\beta$  can be introduced again, with the change -  $d\beta \cdot (E/2) = dY_1^c$  and  $-d\beta \cdot (E_a^c/2) = dY_2^c$ , where the negative sign of the change is lost to the shift of the integration boundaries:

$$\begin{aligned} \sigma^c(t) = & \frac{E}{2} \int_{-\varepsilon_s}^{\varepsilon_s} G_{\alpha,\alpha} \varepsilon(t) d\alpha + \frac{E(E_a^c - E)}{4} p(Y_1^c) \iint_{A'} G_{\alpha,\beta} \varepsilon(t) d\alpha d\beta \\ & + \frac{E_a^c(E_h^c - E_a^c)}{4} p(Y_2^c) \iint_{B'} G_{\alpha,\beta} \varepsilon(t) d\alpha d\beta \quad (7) \end{aligned}$$

The first part of the expression is the elastic stress, while the integration domains represent the areas of the bands between the corresponding lines in a bounded triangle (Figure 5):

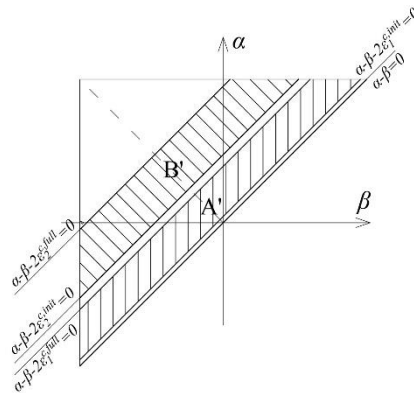


Figure 5 - The Preisach triangle for the material model defined by the expression (7)

#### 4. EXPERIMENTAL RESULTS AND MODEL VERIFICATION

In order to determine the parameters that define the material model correctly, monotonic axial tests are conducted on S275 structural mild steel. The all test

samples are made according to [11]. dimensions of test samples are shown in Figure 6.

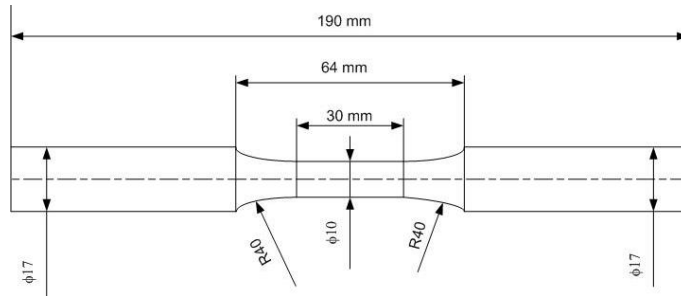


Figure 6 - Specimens dimensions according to [11]

Four samples made of S275 grade structural steel were subjected to symmetrical cyclic stress and a symmetrical load history of the same range  $\varepsilon = \pm 1.5$ . The loading device is SHIMADZU ServoPulser (Figure 7) which is universal tension and compression fatigue testing machine, providing stocky configuration, fine alignment, and restraint of lateral movement of cross-heads.



Figure 7 – Loading device

The extensometer SHOWA-SOKI TCK-1-IF (Figure 8), with gauge length of 25mm, is used for strain measurement. The strain amplitudes are applied with a constant frequency of 1Hz.

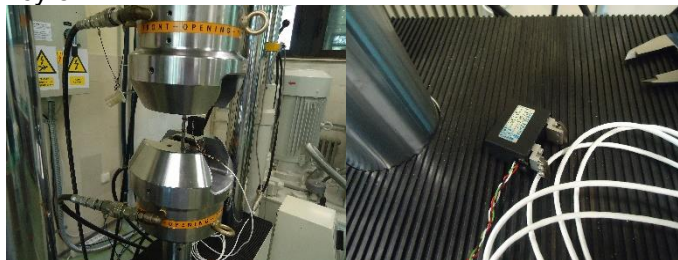


Figure 8 – Strain measurement equipment

A comparison between average test results and analytical model results are shown in Figure 9 [10].

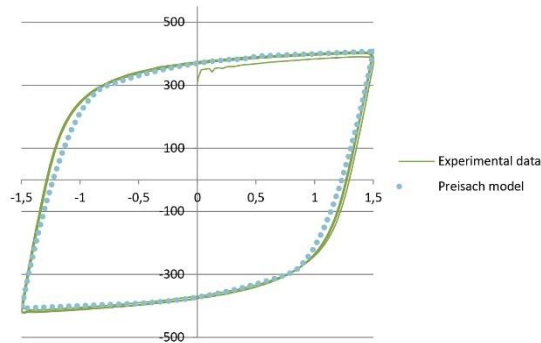


Figure 9- Comparison of experimental and analytical data

## 5. CONCLUSION

The new analytical model that describes the formation of inner hysteresis loops of cyclic loaded structural mild steel elements has been introduced in this paper. Existing Preisach models owing to their simplicity, can not accurately describe the hysteresis loops shape of cyclic-loaded structural steel.

The analytical model developed in this paper belongs to a group of Preisach models, with a very suitable capability of modeling the behavior of structural steel under cyclic loading, which is shown through comparison with experimental results.

Besides the ability to provide excellent agreement with experimental results, the main advantage of this model lies in its convenience for use in engineering practice, as a result of its geometrical interpretation in the form of Preisach triangle.

## REFERENCES

- [1] F. Preisach, **Über die magnetische Nachwirkung**, *Z. Phys*, vol. 94, pp. 277–302, 1935.
- [2] A. V. Lubarda, D. Sumarac, and D. Krajcinovic, **Hysteretic response of ductile materials subjected to cyclic loads**, *Recent Advances in Damage Mechanics and Plasticity, ASME Publication, AMD*, vol. 123, pp. 145–157, 1992.
- [3] V. A. Lubarda, D. Sumarac, and D. Krajcinovic, “Preisach model and hysteretic behaviour of ductile materials,” *European journal of mechanics. A. Solids*, vol. 12, no. 4, pp. 445–470, 1993.
- [4] D. Sumarac and S. Stosic, **The Preisach model for the cyclic bending of elasto-plastic beams**, *European journal of mechanics. A. Solids*, vol. 15, no. 1, pp. 155–172, 1996.
- [5] D. Šumarac and Z. Perovic, **Cyclic plasticity of trusses**, *Archive of Applied Mechanics*, vol. 85, Dec. 2014, doi: 10.1007/s00419-014-0954-7.
- [6] Petar Knežević, Dragoslav Šumarac, Zoran Perović, Čemal Dolićanin, and Zijah Burzić, **A Preisach Model for Monotonic Tension Response of Structural Mild Steel with Damage**, *Periodica Polytechnica Civil Engineering*, vol. 64, no. 1, pp. 296–303, 2020, doi: <https://doi.org/10.3311/PPci.14809>.
- [7] I. D. Mayergoyz, **Mathematical Models of Hysteresis**, New York: *Springer-Verlag*, 1991. Accessed: Mar. 01, 2018. [Online]. Available: <http://www.springer.com/us/book/9781461277675>

- [8] W. D. Iwan, **On a Class of Models for the Yielding Behavior of Continuous and Composite Systems**, *J. Appl. Mech*, vol. 34, no. 3, pp. 612–617, Sep. 1967, doi: 10.1115/1.3607751.
- [9] D. Šumarac and Z. Petrašković, **Hysteretic behavior of rectangular tube (box) sections based on Preisach model**, *Arch Appl Mech*, vol. 82, no. 10, pp. 1663–1673, Oct. 2012, doi: 10.1007/s00419-012-0663-z.
- [10] D. Šumarac, P. Knežević, C. Dolicanin, and M. Cao, **Preisach Elasto-Plastic Model for Mild Steel Hysteretic Behavior-Experimental and Theoretical Considerations**, *Sensors*, vol. 21, p. 3546, May 2021, doi: 10.3390/s21103546.
- [11] E08 Committee, **Test Method for Strain-Controlled Fatigue Testing**, *ASTM International*. doi: 10.1520/E0606-04E01.



# THE POSSIBILITY OF IMPROVING THE ARCHITECTURAL DESIGN OF COMMUNAL AND CIRCULATION AREAS IN PRESCHOOLS USING THE SPACE SYNTAX METHOD

Sofija Ickovski<sup>1</sup>, Milan Tanic<sup>2</sup>

## Abstract

*Besides the group rooms, communal and circulation areas in preschools such as halls and corridors, dining and multipurpose areas, as well as inside and outside playgrounds are the places where children meet, interact and develop their psycho-social competences. In order to improve the design of these spaces it is necessary to implement different strategies. The aim of the study is to determine whether space syntax could help improve the architectural design of the aforementioned spaces in preschools. The paper reports the space syntax analysis applied onto the communal and circulation spaces of one preschool building situated in the city of Nis. The findings suggest that the application of the space syntax method might have a potential in improving the architectural design of these spaces in preschools in order to create functional, safe and engaging environments. Scientific attention might need to be directed towards space syntax in order to study its further application in architectural design of all preschool areas.*

**Key words:** *Preschools, Communal Areas, Circulation Areas, Space Syntax Method, Theoretical Models*

---

<sup>1</sup> PhD student, Faculty of Civil Engineering and Architecture, University of Nis, sofijaickovski12@gmail.com

<sup>2</sup> PhD, Prof., Faculty of Civil Engineering and Architecture, University of Nis, tanicmilan@yahoo.com

## 1. INTRODUCTION

Preschool environments play a crucial role in shaping children's educational, social and emotional experiences and development. Toddlers and preschool age children are in constant, active states of making sense of the world around them, formulating ideas about the way that different pieces of their world fit together based on their experiences. They are also very sensory oriented, and the majority of their “sense making” takes place through exposure to sensory input, where each of their senses is engaged in one way or another, giving them a unique perspective and personal understanding of their environment. The research of Moore (1987) and Evans (2006) has found that the quality of the physical, designed environment of early childhood centres—such factors as size, density, privacy, well-defined activity settings, modified open-plan space, a variety of technical design features, and the quality of outdoor play spaces—is related to children's cognitive, social, and emotional development [1]. Therefore it can be concluded that physical structures designed for preschool children's upbringing and education, i.e. exterior and interior environment, have a multiple influence on cognitive, social and affective development of children [2].

According to the above mentioned preschools are vital environments for children's growth and development, providing opportunities for social interaction and the development of psycho-social competences. Apart from group rooms, which are considered the essential and most significant part of any preschool building, communal and circulation areas may play an important role in fostering meaningful interactions and facilitating children's overall development. Communal areas, such as common rooms, play areas, and dining spaces, foster socialisation, creativity, and collaboration among children. On the other hand, circulation areas, including corridors and staircases, ensure smooth movement and efficient access to different areas within the preschool. Optimal architectural design of these areas can enhance the overall preschool experience, promoting engagement, safety, and a sense of belonging for both children and educators.

This research investigates the potential of the space syntax method as a tool evaluating and improving the architectural design of these areas in preschool settings. By utilising some segments of space syntax analysis, this study aims to identify the spatial configurations and their impact on accessibility, wayfinding, and social connectivity within preschool environments. The findings of this research can provide valuable insights for further employment of space syntax methods in analysing architectural design of preschool objects and thus help architects, educators, and policymakers in creating more effective and child-friendly preschool designs.

## 2. METHODOLOGY

This study deals with the possibility of the space syntax method being applied in analysing the spatial configurations of preschool facilities with the focal point on communal and circulation areas. Therefore, first the space syntax method is described in general providing a comprehensive understanding of its fundamental principles and analytical techniques. After that, the specific application of space syntax theory on the analysis of communal and circulation

areas within preschool facilities was proposed. This utilisation of space syntax theory allows for a deeper understanding of how spatial configuration influences the dynamics and interactions occurring in these particular areas. Finally, one illustrative example of the possible application of space syntax theory was given through the analysis of the spatial configuration of the communal and circulation areas within the *Bubamara* Kindergarten building located in Nis, Serbia.

### **3. CONDUCTED RESEARCH**

In order to understand the huge possibility of using the space syntax method in preschool building analysis it is necessary to get acquainted with the method itself. Thus, the method and its possible application in analysing the communal spaces of a specific preschool building was shown in this section.

#### **3.1. The Space Syntax Method**

In general, the space syntax method is an analytical approach that investigates the relationship between spatial configuration and human behaviour within built environments. The authors of the space syntax method [3] underline the considerable influence of socio-cultural norms on the spatial organisation of buildings. Therefore they offer an analytical method named "space syntax", which applies reading, quantifying, describing, and comparing morphological patterns of buildings for the purpose of projecting the social norms of their inhabitants. The space syntax method considers how spatial layouts and connectivity influence movement patterns, accessibility, and social interactions between children and working staff. By analysing the spatial configuration through techniques such as axial analysis, visibility graph analysis, and integration analysis, the space syntax method provides insights into the hierarchical structure, connectivity, and flow of spaces within a building.

The space syntax method has several phases in its application. To begin with, traditional architectural floor plans are converted into dimensionless representations called permeability diagrams or graph representations. Each livable area in the plan is divided into the largest and fewest number of convex spaces possible. These resulting convex spaces, known as the convex map, may or may not match the actual conceptualization of the building. In the diagram, the convex spaces are depicted as nodes, while the connections between them are shown as lines. The nodes are then arranged in levels above a central "root" node, typically representing the exterior space of the building. The arrangement is based on the number of spaces that need to be traversed to reach each convex space from the outside, or vice versa.

Next, the permeability diagram is used to quantify the fundamental syntactic parameters of integration, connectivity, and control. For simple graphs, these space syntax measurements are manually calculated, while complex graphs can be processed using computer programs. The input provided to the computer program is a matrix of connections derived from the permeability diagrams. By following this approach, the crucial syntactic properties measured include depth, shortest path, and the degree of ringiness [4].

In a graph, the shortest path refers to the minimum number of steps required to travel from one node to another. On the other hand, the degree of ringiness, or distributedness, measures the presence of multiple alternative routes between any pair of nodes. These two characteristics are combined to create a quantitative mathematical measurement called integration or relative asymmetry value (RA). To facilitate direct comparisons regardless of the graph's size, RA values are adjusted between theoretical and empirical limits. This adjusted integration measurement is referred to as Real Relative Asymmetry (RRA). Integration values range from 0 to 1, with lower values indicating higher integration and higher values indicating greater segregation.

### **3.2. Procedures in analysing communal and circulation areas by the space syntax method**

Utilising the space syntax method to observe communal spaces in preschool environments involves a systematic approach that helps analyse the spatial configuration and its impact on social interactions. The first step to start this procedure is a data collection which consists of gathering architectural floor plans or drawings of the preschool facility, including the areas designated as communal spaces. This may include spaces such as play areas, common rooms, dining areas, or corridors. After that, the boundaries of the communal spaces within the floor plan should be defined. This step helps isolate the specific areas of interest for analysis. In order to proceed with the conversion to graph representation some observation methods have to be used [5]. The gate method, static snapshots or people following methods are very suitable for the purpose of corridors and communal areas observation. Also, questionnaires done with the preschool staff, parents and children can be applied. Selecting the appropriate time and periods of observation, as well as appropriate questions, holds utmost significance, for it bears the potential to greatly influence outcomes and yield meaningful insights. In this phase the floor plan is transformed into a graph representation which means that spaces are represented as nodes and connections between them (e.g. doors, corridors) are represented as edges or links. This step is followed by the convex space subdivision in which communal spaces are subdivided into the largest and fewest convex spaces possible. This helps simplify the analysis and allows for a more accurate representation of spatial connectivity. After that the nodes (representing convex spaces) should be arranged in levels, with a "root" node typically representing the outside space. The nodes should be aligned based on the number of spaces to be crossed to reach each convex space from the outside or vice versa.

The final step is a quantitative analysis. Space syntax analysis provides several metrics to quantify the integration, connectivity, visibility, reachability and other relevant properties of communal spaces in preschool buildings.

### **3.3. Analysis of the Preschool Floor Plan**

A selection of floor plans from various preschool buildings was carefully examined to identify the most distinct and diverse designs among them. The analysis of the floor plans revealed a recurring pattern, where the majority exhibited a characteristic feature of narrow and elongated corridors. Upon closer examination, it became apparent that only a limited number of preschool

buildings incorporated distinct communal areas, such as common rooms, play areas, and dining spaces, as separate entities within their floor plans. Therefore, the floor plan of the *Bubamara* kindergarten was carefully selected based on its specific characteristics and considerations [6].

*Bubamara* kindergarten showcases a floor plan (Figure 1) tailored to meet the specific developmental requirements of young children. The entrance leads to a spacious central corridor. On both sides of the corridor, classrooms cater to different age groups. Restrooms are incorporated into group rooms. Additionally, the floor plan encompasses a multipurpose/play area. Kindergarten *Bubamara* is equipped for accommodating, nursing and educating up to 300 children who are organised into eight to ten groups.

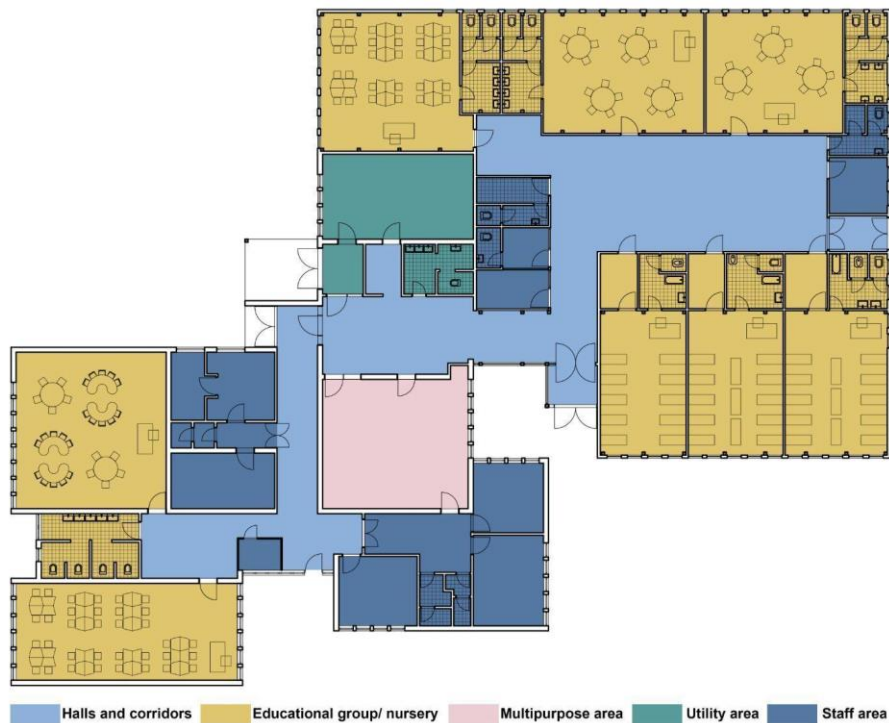


Figure 1. *Bubamara* kindergarten floor plan (Author: S. Ickovski)

### 3.4. Setting the Boundaries of Communal Spaces

In the context of the space syntax method, it is necessary to set the boundaries between formal and informal spaces. Formal and informal spaces refer to different types of areas or zones within the physical environment that serve specific purposes and support various activities and interactions. Thus, formal spaces of a kindergarten refers to group rooms, toilets, staff offices and utility areas while informal spaces are communal spaces, corridors and multipurpose areas. For the purpose of Space Syntax analysis, the informal areas of *Bubamara* kindergarten are coloured in blue (Figure 2) so that the boundaries of the communal spaces are more vivid.



Figure 2. Presentation of the informal area boundaries on the Bubamara kindergarten floor plan (Author: S. Ickovski)

### 3.5. Observation Methods

Different observation methods can be applied in observing informal areas of *Bubamara* Kindergarten. Maybe the most suitable are the gate method, static snapshots or people following methods. Which one will be used depends on the goals and the purpose of observation.

The gate method would be suitable for recording the fluidity of *Bubamara* kindergarten corridors. First, a number of exact spots, locations, should be chosen. A range of well-used, moderately-used and poorly-used spaces should be covered. However, a more accurate picture of the pattern of movement will be obtained by observing as many gates as possible. In the case of *Bubamara* kindergarten 10 spots, as shown in Figure 3, would be enough.



Figure 3. Example of 10 “gates” marked on the informal area of the Bubamara kindergarten floor plan (Author: S.Ickovski)

The observation should be taken for exactly 3 minutes five times a day during one working week. The minimum level of observation should be two rounds in each time period. Different categories should be counted at the same time: children, educators, other staff, parents. Observations should be recorded on a prepared table. It is best to do a tally count as shown in Figure 4.

In the morning from 7.30 to 8.15					
Gate Number	Time	Moving Children	Moving Educators	Moving Other Staff	Moving Parents
1	7 30	<del>    </del>	==		===
2	7 35		—	==	
3	7 40		—		===
4	7 45			=	
5	7 50	===	=		===

Figure 4. Example of a tally count table (Author: S.Ickovski)

Statistic snapshots method is especially relevant to recording the use pattern of spaces within buildings. Therefore, nine spots in the communal areas of Bubamara kindergarten should be observed (Figure 5).

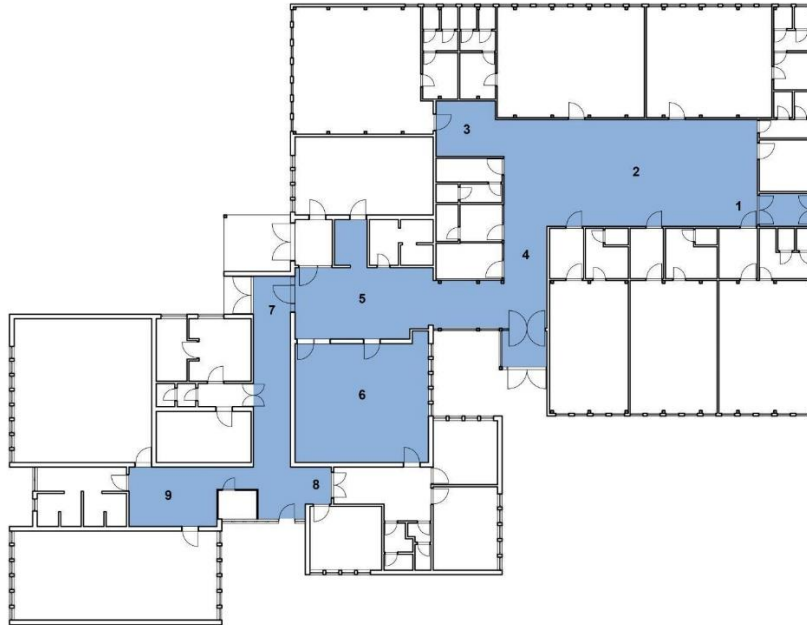


Figure 5: Nine observation spots marked in communal area on the Bubamara kindergarten floor plan (Author: S.Ickovski)

A researcher should walk from spot to spot and take a mental snapshot of the activity taking place at the very exact time. The snapshot is then recorded on the plan, with coding according to activity. The activities which should be observed are: sitting, standing and walking. In addition, talking (whether a person is sitting, standing or walking) should be recorded. The convention for each category is indicated in the diagram below (Figure 6).

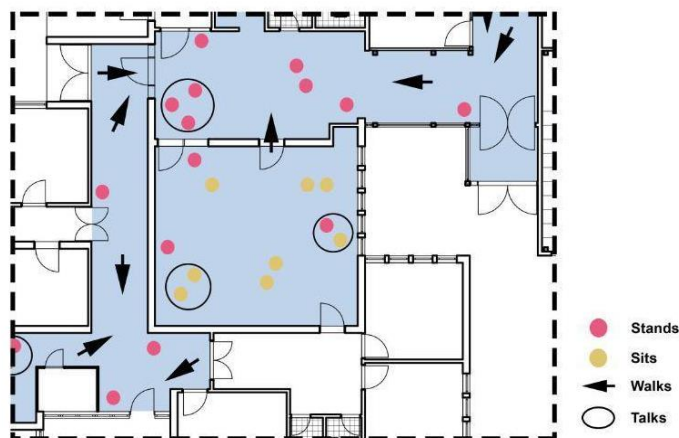


Figure 6: Example of a single snapshot recorded on the Bubamara kindergarten floor plan (Author: S.Ickovski)

A separate and blank plan should be used for each observation round and observations should be undertaken throughout the whole of a working day. In general, two snapshots per time period should be made, over at least two different working days.



The following method is an important technique for observing people's movement from specific points in space. An observer traces the routes people are taking. In this case, different categories of people should be followed (children, staff members, parents). At least five spots should be picked to start following from (Figure 7).

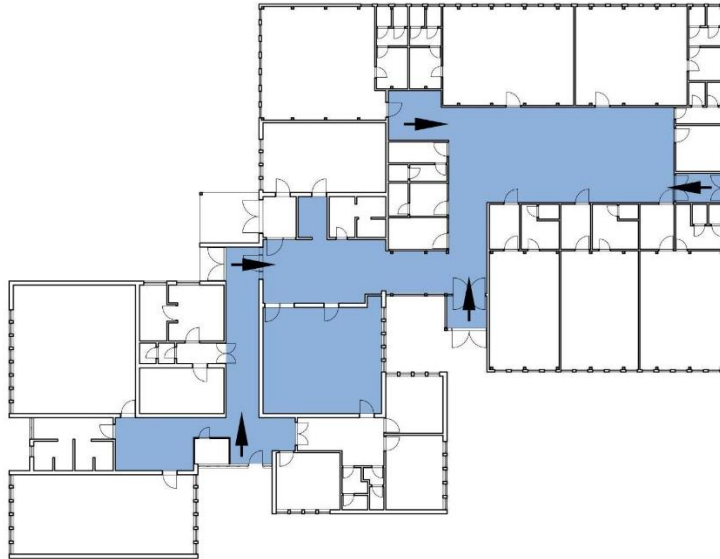


Figure 7: An example of 5 spots to start following from marked on the Bubamara kindergarten floor plan (Author: S.Ickovski)

Important techniques for collecting data are questionnaires. These should be done with the preschool staff, parents and children. The questionnaires usually consist of specific and narrowly defined questions.

### 3.6. Space Syntax Software Application

At this point of the research, a Space Syntax software should be applied. Its application can provide valuable insights in understanding the usage patterns of communal spaces in preschool environments.

The software can analyse the spatial layout of the preschool, including the arrangement of classrooms, corridors, play areas, and communal spaces. By examining the connectivity and accessibility of these spaces, it can identify the potential patterns of movement and interaction. Also, the software can generate visual representations such as maps, diagrams, and graphs to depict the spatial relationships within the preschool. These visualisations can help identify spatial hierarchies, focal points, and areas with high or low levels of interaction. Using the software, the paths that individuals take within the preschool environment can be analysed. It can reveal the preferred routes and areas of congestion, helping to optimise the layout and circulation flow of communal spaces.

By combining spatial analysis with observational data, the software can help map social interactions within communal spaces. It can identify areas where children tend to gather, engage in play, or have conversations. This information can assist in designing spaces that promote positive social interactions and facilitate collaborative activities.

It is also very important to underline that Space Syntax software applications often incorporate predictive modelling capabilities. By inputting different design scenarios or proposed changes to the spatial layout, the software can simulate and predict their potential impact on the usage patterns of communal spaces. This can inform decision-making processes and optimise the design of preschool environments.

#### 4. RESULTS AND DISCUSSION

As seen in the above chapter, the space syntax method has a series of predefined techniques and procedures which should be followed in order to get a precise analysis of a specific space within a building. The space syntax method is not only applying the Space Syntax software but comparing and analysing its results with the observation and questionnaire results.

Therefore this study can be also seen as a preparation phase for the fully applied space syntax method in analysing *Bubamara* kindergarten building. The accurate *Bubamara* kindergarten floor plan is given which will be used in the Space Syntax Software in order to identify key spatial attributes of this preschool building. Some potential outcomes and analyses that could be obtained are:

- **Connectivity Analysis:** The software would evaluate the connections between different areas within the kindergarten.
- **Integration Analysis:** The software would assess the level of integration among different areas of the kindergarten. It would measure how easily individuals can move between spaces and determine which areas are more integrated or segregated.
- **Accessibility Analysis:** The software would analyse the ease of access to different spaces within the kindergarten. It would consider factors like proximity, distance, and connectivity to entrances, exits, and other important areas.
- **Visibility Analysis:** The software would evaluate the visibility and visual connectivity between spaces. It would identify areas that provide clear lines of sight and visual supervision, enhancing safety and monitoring capabilities.
- **Spatial Analysis:** The software would generate visual representations, such as maps or diagrams, highlighting the spatial properties of the kindergarten. It may identify central or focal areas, areas with higher or lower movement potential, and areas with potential congestion or bottlenecks.
- **Behavioural Analysis:** Based on the spatial configuration, the software can also predict and simulate potential movement patterns, circulation flows, and social interactions within the kindergarten. It could help understand how spatial design influences children's behaviour and activity within the environment.

Besides the use of the Space Syntax software, at least three different types of on-site observations could be used in order to exhibit how children and adults use the communal spaces and note the patterns of movement, gathering, and interaction within a preschool building.

Furthermore, for the purpose of collecting more data on the usage and importance of communal space different types of surveys can be done with teachers, parents or other stakeholders.

The full potential of the space syntax method could be seen only if all these techniques were applied (the software, on-site observations, surveys) and thus gathered data compared and analysed.

## 5. CONCLUSION

The objective of this study was to explore the potential effectiveness of employing space syntax analysis in enhancing the design of communal and circulation spaces within preschools. Space syntax is a research based approach for understanding and evaluating architectural spaces and as such it can readily be applied in analysing communal and circulation areas within kindergartens. In order to do so, it is necessary to follow the space syntax procedure which generally comprises of the following steps: (1) collect relevant data (on-site observations, surveys, and gathering architectural floor plans), (2) analyse the collected data, (3) analyse the architectural floor plans using space syntax software, (4) utilise depthmap software to generate depth maps and finally (5) apply statistical techniques to examine correlations between spatial variables and observed social behaviours. It is important to note that the specific implementation of the space syntax method may vary depending on the research context and available resources.

Having in mind the previous stated as well as the description of a procedure techniques applied on *Bubamara* kindergarten given in this study, it is evident that employing space syntax theory in investigating communal and circulation areas in preschool buildings may help understand how these spaces impact the movement patterns, social exchanges, and overall engagement of young children within the environment.

As a result of the study, it can be concluded that the integration of the space syntax method into the design process can contribute to the creation of inclusive preschool communal and circulation areas as meeting points where children can engage in social interactions, develop their communication skills, and enhance their psycho-social competences.

## REFERENCES

- [1] Gary Moore, T. Sugiuama , L. Donell, **Children Physical Environment Rating Scale**, *Children, Youth and Environments*, Vol.17(4), 24-53, 2007
- [2] Stankovic, D., Tanic, M., Kostic, A., Vrecic, S., Kekovic, A., Cekic, N., Nikolic, N., **Resurgence of Indoor Environment Of Preschool Building**, *Procedia Engineering*, Vol.117, 737 – 750, 2015
- [3] Hillier, B., & Hanson, J., **The Social Logic of Space**, Cambridge, New York: Cambridge University Press (1984)
- [4] <https://www.spacesyntax.online/applying-space-syntax/building-methods/spatial-form-analysis/> (27.06.2023.)
- [5] <https://dokumen.tips/documents/space-syntax-observation-manual.html> (28.06.2023.)
- [6] Stankovic, D., Tanic, M., et al. **Revitalization of Preschool Facilities in Serbia**, Faculty of Civil Engineering and Architecture, University of Nis, Nis, 2013

# ARTS AND ARCHITECTURAL COLLABORATIONS IN ATHENS OF THE SIXTIES (60S)

Dimitris Grigoriou<sup>1</sup>

## Abstract

*The aim of this research study is the investigation of dialogue between Modern Greek Architecture and Art in the decade of 1960, the way this was expressed in architectural projects of holistic design with mutual participation of Architecture and Visual Art.*

*The subject of the study includes architectural projects of holistic design with mutual participation of architecture and visual arts that occurred in the decade of 1960 in Greece and that they usually form products of cooperation between artists and architects or they are exclusively architectural projects. They are about Visual Art projects, sculptures, embossed, engravings, tapestry, shop window compositions etc. that were especially designed to be part of the holistic design of many buildings, mostly of public interest and rarely of residences.*

*The research inquiries that the study will attend to answer, among others, are the following:*

- Which architects encouraged the establishment of dialogue between Art and Architecture during the decades of 1960-1970 in Greece?*
- What forms of Art are those that mostly cooperate with Modern Greek Architecture at that period and how this is interpreted?*
- What are the factors that lead to this practice and to what type of buildings one can see the synergy of Art and Architecture?*

**Key words:** *modernism, visual art, architecture, collaborations, Athens, sixties*

---

<sup>1</sup> Architect (Dip.Arch + M.Eng), School of Architecture – Technical University of Crete  
Art History and Theory (MA), Faculty of Fine and Applied Arts – Cyprus University of Technology  
PhD Candidate, School of Architecture – Technical University of Crete  
dgrigoriou@tuc.gr

## 1. INTRODUCTION

The tradition of collaboration between architect and artist was “transmitted” by the Greeks in the “West” and was continued, advanced from Roman times till it’s thriving in Renaissance, when some of the greatest artists were architects at the same time, granting in such prodigy the most ideal type of collaboration. In Greece, the continuators of this tradition were the tile artists and painters in Byzantium, who cooperated with architects for churches’ and palaces’ decoration.

In post-war Greece, despite some exceptions, the architects ignore the artists, either due to great self-confidence, or due to lack of education and means. Therefore, even though they delivered a newly built Athens, the town was artless. Synergies of a modern architecture and art make their appearance in the end of 50’s and continue without break during 60’s – afterwards they continue sporadically, tending nowadays to disappear. This period, is called “architectural spring” of 60’s, consists the second most important period of modern Greek architecture after the unprecedented modern decade of 30’s . In both – unfortunately short term – periods of creative optimism, the attempts of the new architects at that time, to follow the west movements and standards, truly adapted to Greek conditions and peculiarities, administered great quality’s public and private works, distributed in all the functional categories (it is not random that lately the architectural research focuses on these decades). At the same time not only a lot of cooperations flourished among architects but also synergies among architects and visual artists.

## 2. METHODOLOGY

### 2.1. Method of collecting the material

As for the method of collecting survey’s material was carried out: 1. Archival survey (archives: George Zongolopoulos foundation, Eleni Vernadaki personal archive and Ioannis Koutsis personal archive), 2. Field research, 3. Press research, 4. Bibliographical research, 5. Internet research.

### 2.2. Constitution and content

The interpretive method that was chosen to be used is the study of synergies between art and architecture in Greece, either appeared inside or outside a building totality. The studied period is the 60’s, which deals with the dialogue and introduction of the arts in the architecture’s idiosyncrasy and synthesis. The material of the research, is consisted by four units, which are divided as:

- a) Painting works in architectural synthesis
- b) Sculpting works in architectural synthesis
- c) Other applied arts in architectural synthesis
- d) Works of art by architects in architectural synthesis.

The above-mentioned works consist an integral part of the architectural synthesis. Some of them were created as a result of the cooperation between an architect and a visual artist, while others from a post – interference of the visual artist on the edifice, knowing always the synthesis – principles of the architect, so it becomes attuned with it.

### 3. FINDINGS (RESULTS)

#### 3.1. Ainting works in architectural synthesis

Interestingly, there is a focus on the Greek expression on the works of that period. The designs and outlines below express “the terror of the void” that consists a basic feature of folk art, incorporating a vast amount of linear, designed patterns. In the consensus of this period, which appears rich and heterogeneous, the painter tries all the expressive means, transforming the priorities from the new work to another. In some cases the colour outweighs, in others the order of the forms, sometimes “touches” cubism while in others the terms of Byzantine tradition are evaluated. [1]

During the turn of 60's, it was under construction the “Katakouzinios' residence” in Athens, which was destined to host the clinic of psychiatrist Katakouzinios. Among the huge size works of painting, four mahogany doors are distinctive by Nikos Chatzikyriakos Ghikas, painted especially for Katakouzinios couple, Aggelos and Lito. The doors were placed in a “key” point to divide the space into two independent functions: the couple's residence and the psychiatrist's office. Given the sensitivity of the specific space the artist tries to show the wild beauty of the Greek landscape through a synthesis easy on the eye. Being a genuine member of 30's generation he uses intense and bright colours in an attempt to capture the “harsh” Greek light, like Spyros Papaloukas the aim was to keep the patient in a full mental and corporal peace while he/she was in the waiting room for the doctor's session [Figure 1].



*Figure 1. View of the two-leaf mahogany door. composed by Nikos Hatzikyriakos-Ghikas, <https://www.thetoc.gr/politismos/article/i-istoria-enos-spitiou-mouseiou-kathrefti-tis-pneumatikis-elladas> (11/09/2019)*

In 1963, Ioannis Moralis created his friend's and music composer's flat Manos Chatzidakis in Athens. The work was named by Manos Chatzidakis “a spring ritual”. Respecting the beliefs and perceptions of Chatzidakis - who characterized himself as a burgher – observer and not a plebeian – tried to set them in perfect harmony to the space regarding the colour and the geometry. The synthesis took over all the wall's surface, which the artist distributes in three parts with an equivalent status in space. From left to right: a) we can see the meaning of devotion in the work and in “pentagram's synthesis”. That's why the first synthesis is in a direct line with the piano. b) the central sector represents the philosophy of relaxation and meditation (armchair), c) the right part through which Chatzidakis calls himself to be stand by, envision and compose, sat behind his office [Figure 2].

Three years later Konstantinos Doxiadis astonished by the designs that I. Moralis created for George Seferis' book, asked him to create a frieze<sup>2</sup> for his flat in Athens. The aim was an "opening" for a communication gate with the past, showing Athens that seduced him and making the observe to provoke his/her subconscious, something like a flash-back of the dipole space-time. Taking into consideration the linear dimensions of the frame that was going to be fitted, the illumination of the room, also the fact that the specific frame would be an integral part of the total frieze's surface, he perceived as a topic Athens from antiquity till nowadays, which he presented in five synthesis. Each one was depicting Athens in different periods such as Classical, Roman, Byzantine, Neoclassical and Modern. This synthesis is a shade-game inside space, as Moralis said, because sun rays – as they fall from the side outlets- watch the history of Athenian civilization as it thrived, decayed, reborn and finally decayed again. The light-game starts rising from the right synthesis which represents antiquity. Afterwards in ancient Athens the shades are extensive, they become less in Roman, much less in Byzantine, in Neoclassical they are vertical while in Modern fall from the left signifying the set and the point of decay [Figure 3].



Figure 2. *Painting composition in Manos Chatzidakis' flat. Belemezi Louiza-Maria, Karachalios Sotiris: Από τη ζωγραφική στην αρχιτεκτονική, National Technical University of Athens, Athens, 41, 2012.*



Figure 3. *Living-room in Constantinos Doxiadis' flat. Θέματα Εσωτερικού Χώρου 1, 28, 1970.*

### 3.2. **Culpting works in architectural synthesis**

Painting and sculpting which were, until recently, the major mimic arts, when they had to represent a form they should solve a double problem: not only to imitate correctly and convincingly their pattern but also to give it a characteristic and interesting posture. They had to resolve not only the representation problem but also the posture of the object (the second was harsher) if someone extends the meaning

<sup>2</sup> 1966, Ioannis Moralis: Five paintings (oil in canvas) dimensions 1,46 x 0,62 m. each one.

this further from the characteristic one of the pattern – which isn't natural – and it gives the idea of a symbolic form. Undoubtedly, the sculptures contributed in the establishment of architectural and artistic synergy inside each architect's and artist's consciousness. The keystone was the suggestions and applications of embossed syntheses through an artistic array simultaneously combined with the inception of composing principles and intentions from the architects.

The initiative was made by I. Moralis inside Hilton Hotel in Athens<sup>3</sup> which had to do with the entire facade of the complex with a background of Vasilissis Sofias street. As he said, "At first, I paid attention to the axis, so as the synthesis not to be inclined because the street was going downwards. Because the right side is like this I gave the entire movement of the synthesis to the left." The huge dimensions, the unusual material for a painter (sub yellow marble from Ioannina) and the restricting instructions from the owners as for its status and thematology, impose problems to Moralis that he has not faced before. The instructions were clear about having patterns and presentations from ancient Athens that are distinctive, from distance, to a common "tourist" [Figure 4].



Figure 4. The NW façade of the Hilton Hotel in Athens, *Θέματα Εσωτερικού Χώρου* 1, 28, 1970. *Αρχιτεκτονική Monthly Magazine*, October, 9, 1963.

A lot of synergies became a reality for public places, places of interpersonal activities between professional-assistants and customers – consumers – tourists.

According to the work of Moralis mentioned above, Paris Prekas created the synthesis *time's pace* with brass leaves that covered the whole surface of the main space's wall, in National Bank of Greece branch at Stadiou street,<sup>4</sup> this was covering the waiting room and the counters. He used the method, that French call "au repousser". Inspired from the term's meaning that time-money is vital in bank activities, he puts time symbols, such as: hours, days, weeks, months, years with a secret way that only the ingenious observer can distinguish. It was illuminated twenty-four hours a day, giving to the space prestige as it could be seen from Syntagma Square [Figure 5].

Dedicated to the relation of movement, space and time was also the sculptor Thodoros, who intends his work in a hotel reception lobby in Thessaloniki<sup>5</sup> to incorporate it inside tourists and employee's consciousness. He uses independent pointed and firm forms, emphasizing the importance of these two meanings' co-

<sup>3</sup> 1958-60, Architects: Emmanuel Vourekas, Prokopis Vasiliadis, Spyros Staikos. Ioannis Moralis: Composition of the northwest side of the hotel.

<sup>4</sup> 1965, Architect: Konstantinos Dekavallas. Paris Prekas: wall covering with bronze leaves. Dimensions 13 x 6 m.

<sup>5</sup> Metal sculptures as wall synthesis.



existence, as the key to success. He sets his sculpture to the wall above the elevator as he intends to represent its mechanism. He tried the size of his work to be discreet in space and on the specific wall's surface, as he wanted to make a reference to the value of mechanism's existence, but not to cove the meaning of the cage-box that function together. He sets as a target to emphasize the meaning of elevator's constant operation, the transportation for people and loads in time and the space saving, in contrast to the usual method of ascent through stairs [Figure 6].



Figure 5. The transaction area in a National Bank of Greece brunch. *Θέματα Εσωτερικού Χώρου 1, 104, 1970.*

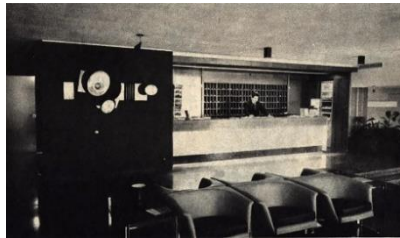


Figure 6. Sculpture work by Theodoros into the shear wall of the elevator in a hotel, Thessaloniki. *Θέματα Εσωτερικού Χώρου 1, 75, 1970.*

### 3.3. Other applied arts in architectural synthesis

After the sculpting works, some dared to take the next “leap” which would fulfill and ascertain the establishment of arts’ presence inside and outside architectural synthesis, product of a new perception for dealing with the space inside a visual artist but mostly architectural frame. The breakthrough is that the architect cooperates with the visual artist and he, in turn, with the technician / craftsman for works execution. Ceramic syntheses’ works lifted off this category – mostly during this decade’s second half – as they appear in buildings that host or are used by a variety of population. Many times, the chosen themes “touch” the Greek public, as for the very first time modern Neohellenic art recalls history giving to the space monumental features gaining this way the interest and amazement.

Between architecture and ceramic dominates an unbreakable relationship among material – form – technique from archetypes to their “cogitative” adaptations in site, era, intension of the creators and sensitivity that each one of these two arts gives off. It’s known that ceramics, as architecture, is linked with civilization and observes in every period the cultural evolution of human. Excavations’ archaeological findings confirm this relationship. [2]

Ceramic art stays this way “wisely decorative” for Citibank’s branch on Tsimiski street in Thessaloniki,<sup>6</sup> Moralis tries to approach Byzantine Thessaloniki, mostly by using ceramic material and colours (brown - gold).<sup>7</sup> This impression is caused in front of people’s eyes who see a small representation of their old city inside a modern building. The elements that the artist uses alternate in the synthesis’ center with rhythm, while sunlight’s play on ceramic plates’ surfaces has a dominant role in space as far as final result concerned [Figure 7].

Ceramic synthesis for the restaurant of Athens Airport in Ellinikon (Eastern Terminal)<sup>8</sup> was E. Vernadaki’s first full work for a public building, after her first cooperation with Moralis. The synthesis<sup>58</sup> extended on the whole long wall of the room, while the wall opposite from glass plates was giving to the visitors a view to the airport, the sea and horizon. The artist created designs with inner and outer embossed, geometrical patterns, which rhythmically repeated, by plan, on the whole surface and interchange with flat plates [Figure 8]. [3]



Figure 7. Ground floor area of Citibank brunch in Tsimiski str. during working hours after the completion of the ceramic work. *Θέματα Εσωτερικού Χώρου* 1, 79, 1970.

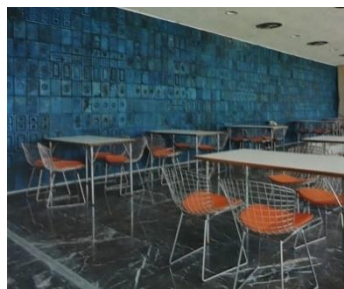


Figure 8. View of Elliniko airport restaurant area. *Alexaki Evgenia: Eleni Vernadaki, Benaki Museum, Athens, 418, 2016.*

Just before the 60’s, especially in 1958, the “Athens School of Fine Arts” organized for first time in Athens “Display window’s week”. Accordingly, a topic set in the front scene: Display window from an aesthetic aspect. This event was a success among the traders which shows that there was a “fertile ground” for this. Out of the 30 shop owners that received an invitation to participate in this event, more than 20 accepted to give their windows for the students to decorate them. The

<sup>6</sup> 1968, Architects: Thimios Papayiannis, Ioanna Benechoutsou. Ioannis Moralis: Ceramic composition in a wall with relief plates dimensioned 17,50 x 5,00 m. Ceramic performance: Eleni Vernadaki.

<sup>7</sup> A lot of small plates (dim. 30 x 15 cm) were chosen for the wall covering. For these, clay’s colour was used while in coves either dark Brown or gold. The theme is subtractive and has a repetition of elements as patterns. The artist says that his while work consists of 9 elements that he calls “stamps”.

<sup>8</sup> 1969, Architect: Eero Saarinen. Eleni Vernadaki: Ceramic composition and installation in a wall, dim. 3 x 14 m, with relief and engraved plates.

result was magnificent. Windows presented had a great impact to the public because of their great taste and excellent execution. The best were “El Greco’s”, “Etam’s”, “Izola’s” [Figure 9] and Tzannis’. The experiment was repeated the next year with a greater success. The same windows were distinguished plus Maggiorou’s “Piraiki Patraiki”, Mourtzopoulos’ [Figure 10] and Marinopoulos’. From then this week stabilized. In the turn of this decade the Athens School of Fine Arts prepared its third expedition in the beginning of June.



Figure 9. View of Izola shop window in Panepistimiou str., Athens. Ζυγός, 65, May-June 1961.



Figure 10. View of Mourtzopoulos' shop window, decorated by Lida Gaitanou and Mimika Petsa in 1958. Ζυγός, 40, March 1961.

The installation of tapisserie in this decade undergoes a renaissance despite the fact that the modern inner space doesn't have the practical need of its function. It needs though its aesthetic presence. [4]

Moralis' wall painting for “Okeanis” restaurant in Vouliagmeni [Figure 11], [5] initiated a tendency of printing and reproduction for art works inside architectural synthesis, but only if the place that their copy will be set it would be taken under consideration for the space's design. In a next stage with his suggestions for the introduction of some of his work on the applied art of tappiserie, he didn't act with a similar way. This is because he doesn't come into contact with the architect, but he undertakes the work – or the layout – from the owner and he is called to work in this already designed space, adapting his art on it. This applied art was mostly for main areas of residences, whether they were living rooms or other isolation rooms and they had the same status wherever they were situated.

In his work situated on a living room's wall<sup>9</sup> of an Athenian residence [Figure 12], the depicting of the human element represents the human contact, the conversation and involvement of the hosts and quests inside residence's living room.

<sup>9</sup> 1960, Ioannis Moralis: «Immersed State». Dimensions 4,25 x 2,46 m. Tapisserie workshop of Royal Welfare. Managed by Ioannis Faitakis.



Figure 11. Moralis' synthesis in Okeanis hall in Vouliagmeni, Athens 1960. *Αρχιτεκτονική*, issue 42, 11, 1963.



Figure 12. View of the living room in an Athenian flat and Moralis' synthesis. *Θέματα Εσωτερικού Χώρου* 1, 115, 1970.

### 3.4. Works of art by architects in architectural synthesis

The co-existence of visual art's work with architecture creates a synthesis open to interpretations. This work consists a part of architecture, the viewer can anticipate it with two ways. Firstly, as an invitation for a life's experience and secondly, as an invitation for a life's experience about space. It doesn't dictate a specific way of understanding but it creates an open field of experiential approaches that allows the individual to make its relationship with art an unconscious contact. [6]

This auspicious cooperation was confirmed by a lot of architects, who took decisions of artistic nature for their structure. Works of painting but mostly sculpting exist inside and outside buildings space, emphasizing the flexibility of this architect's two-dimensional role.

For the enclosure wall of a single residence in Voula,<sup>10</sup> the architect Ioannis G. Koutsis, created a synthesis on a wall made with reinforced concrete and he faced it as a sculpture. The wall and the sculpture were covered and armed as a totality the depict geometries that come from the initial perception of residence's bulk using the method of deconstruction and fragmentation [Figure 13].

In a block of flats in Psychiko,<sup>11</sup> designed by Takis C. Zenetos, the interest of each visitor focuses on the unique method of administration for the entrance and space, the architect, because of his admiration for art, creates sculpting from concrete rocks in combination with liquid element [Figure 14]. The specific place didn't have enough sunlight so the chances for the "green" to grow up were zero. Therefore, a garden with "waters" created. The concrete unshaped forms represent the sun of stone elements that frame the natural, liquid surfaces. Additionally, the variety of levels and plate's "breaking" give a different status for this work. So, T. C. Zenetos creates an interesting game with "tripole" shape – material – levels.

<sup>10</sup> Architect: Ioannis G. Koutsis. Composition on a reinforced concrete wall.

<sup>11</sup> 1970 (designed), 1972 (completed), Architects: Takis C. Zenetos, T. Georgakopoulos (partner). Takis C. Zenetos: rock sculpture made of reinforced concrete in the main entrance and in the ground-floor's outdoor space.

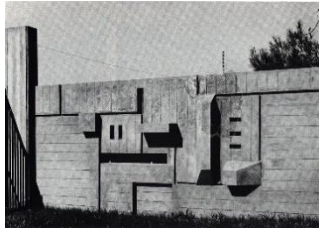


Figure 13. The synthesis on the enclosure wall. *Θέματα Χώρου + Τεχνών 3, 30, 1972.*



Figure 14. View of the pilotis of the residential building in Psychiko from the side of the main façade. *Θέματα Χώρου + Τεχνών 4, 34, 1973.*

#### 4. DISCUSSION

From antiquity architects were calling artists to collaborate for the aesthetic fulfilment of their buildings. Not only for the temples, where the cooperation between painter – sculptor was compulsive for worship reasons, but for the public – buildings that were decorated by period's greatest artists. [7]

During 50's, mostly in Athens, where most of the new buildings are erected, there is a deficiency of aesthetics for new constructions. Except for anarchy and ugliness, which is referred to a huge part of the built environment and it's not an exclusive responsibility for the architects and urban planners but also for the costumers, there is a belief that the existence of an elementary painting and art would make a building aesthetically bearable. However, architects ignored artists and this is because of their self-confidence or because of education and means deficiency.

Nevertheless, the beginning of a new situation comes for a Modern Greek architecture of "prestige". This breakthrough doesn't coincide with the financial and political ones of the country, which happen earlier. This period of architecture's changing, mostly in buildings with architectural prestige, goes along with reconstruction's period. Made in a scale of political oppression for regime's opponents, the reconstruction reveals that the dominant ideology has been undergone a total transformation. In place of heroism and romance of previous periods, comes pragmatism, cynicism and affluence as the ideology of the prime class becomes obviously financial.

During 60's the new designers of the generation will give a battle for a complete change. They had to choose between the Greek element and the opening to international changes. The delay in Greece is well-known, as far as Europe concerned, and the domination of subtractive tendencies. Almost at the same time we see in the "opposite bank" the supporters of tradition to take action. The new generation denies to success, doubt about this value and become a transmitter of new ideas and perceptions. [8]

A lot of architects, designers and engineers cooperated with visual artists so in order to elevate the 20th century's Greek architecture. Some of them discuss with visual artists and compose inside the same studio, sharing even the work bench. The most important were: Ilias Kritikos, Aliki Toufexi, Filippos S. Vokos, Ioannis Vikelas, Kleon Krantonellis, Savvas Kontaratos, Seva Karakosta, Alexandros N. Tombazis technical office, Prokopis Vassiliadis, George Bogdanos, Dimitris Koutsoudakis, Ioannis Triantafyllidis and Nikos Kalogeras.

The majority of them though, gave their works afterwards to the visual artists, making them this way to incorporate their works either inside or outside the construction's space. The target was the absorption of the work from the part of the building that was going to be fitted and also the discussion with the inception of architect's synthesis as far as space's confrontation concerned. The most important among those were: Aikaterini Dialisma, Ioannis Triantafyllidis, Emmanuel Vourekas, Prokopis Vassiliadis, Spyros Staikos, Konstantinos Dekavallas, D. Kapsambelis, Vangelis Sideris, Kyriakos Kyriakidis, Thimios Papayiannis, Ioanna Benechoutsou, Aris Konstantinidis, Manos Mekios, Tasos Biris and Pavlos Mylonas.

However, there were architects<sup>12</sup> like T. Zenetos, P. Kalantzopoulos, A. Konstantinidis, I. Koutsis who with their own intervention reinforce their architectural design, incorporating their artistic talent inside it as a synthesis' element. It was obvious that for the successful fulfilment of their works they needed the best devotion and training in architectural - composing and visual artistic level.

Every visual art appears in full harmony with the building taking into consideration Greece's fight for reconstruction and modernization after the previous decades' wounds. Painters become sculptors, sculptors become ceramists, and ceramists become engravers giving the sign for an art's recycling through architectural synthesis. Their presence, but mostly their actions, were well understood and efficient, transform every public building into an exhibitional space with works of art to co-exist and complete each other. The same as for the residences in which a gallery becomes alive. The meaning of "inhabiting" is redefined, negotiating new era's subjects.

The artist becomes necessary to the technician as to the craftsman and is respected by the society and lives inside his own creations. Whenever every Greek architect understands the necessity of a triple function craftsman – artist – technician then and only then they can be sure that the works are effective. [9]

It is obvious that most of the painters and engravers gave the real object's form, either keeping their natural being or reaching to courageous subtractions. The latter, are included in one with Europe's subtractive tendency without cutting off their contact with the real form. This doesn't mean that our artists are conservative and academic. Inside their works someone can observe modern, daring, progressive and even extreme tendencies. Of course, newer artists are more progressive. [10]

## 5. CONCLUSION

Evaluating the situation from a distance, it is fair to recognize that never before, architecture was more distant/unfamiliar from visual arts, as the days which had followed. After this studied decade, despite some exceptions, there weren't

---

<sup>12</sup> The majority belongs to the second generation of graduates from the School of Architecture of National Technical University of Athens.

architects to continue this kind of intervention in edifices that the studied. The fabulous sleekness of faceless granite, the extensive glass plates that make a building architectural weaker than robust, even inconsiderate use of neoclassic elements from past architectures make our perception about the image of modern buildings. All these, buildings / images / application of new materials in accordance with their intentions for contemporary architecture, compose a picture whose meaning will be judged later. Now let's register as many as we can, because everything will be needed.

The problems of arts' and architectures' synergies are complex with outer – artistic factors, financial consequences and scientific breakthroughs, with the greatest minds of mass production and industrial development that dominate, with the technical equipment which is competitive and exhausting. Furthermore, on here the quality inside these factors' chaos it's the most viable power that gives a warm content to the cold logic. It's the last word that accompanies engravings inside their industrial expression. Quality reassures responsibility's destination, links and dictates techniques and art to their broader expression and far from stability's danger. [11]

Somebody could say that a big amount of responsibility it's because the alienation of architectural departments to those of fine arts and their integration inside the field of engineering or even their full "independence". With this way the architect from mason becomes a mason's violation in the altar of "sufficiency studies", digital modeling and work market, ignoring the manifests, works and huge ideas. The complete compromise.

## REFERENCES

- [1] Xydia Vasiliki: Τέχνη και Βιογραφία: Η περίπτωση του Γιάννη Τσαρούχη και του Νίκου Χατζηκυριάκου – Γκίκα, *Aristotle University of Thessaloniki*, Thessaloniki, 136-137, 2015.
- [2] See Souzana Antonakaki "Relations and origins of ceramic-architecture in the work of Eleni Vernadaki", Alexaki Evgenia: **Eleni Vernadaki**, *Benaki Museum*, Athens, 444, 2016.
- [3] Alexaki Evgenia: **Eleni Vernadaki**, *Benaki Museum*, Athens, 417-418, 2016.
- [4] Dimakopoulou Julia: New species of tapisseries into famous Greek painters works at the Gallery 'Nees Morfes', *Zυγός*, November-December, 85-88, 1973.
- [5] Xydis G. Alexandros: Auspicious collaboration of art and architecture. The work of Yannis Moralis 1959-1963, *Αρχιτεκτονική*, issue 42, 11, 1963.
- [6] Kanellaki Anna: Συνέργειες αρχιτεκτόνων – καλλιτεχνών στην Ελλάδα από τη δεκαετία του '60 μέχρι σήμερα, *Technical University of Crete*, Chania, 16-17, 2013.
- [7] Xydis G. Alexandros: Op. cit., 7.
- [8] Spiteris Tonis: **3 Αιώνες Νεοελληνικής Τέχνης 1660-1967**, *Papyros Press*, vol. B, Athens, 285-286, 1979.
- [9] Xydis G. Alexandros: Op. cit., 15.
- [10] "Conclusion", **Νεοελληνική Τέχνη**, *Alpha Bank Collection*, Thessaloniki, 2006.
- [11] Alevizios Anastasios (Tassos): **The power of engravings**, *Zυγός*, January, 50, 1964.

# EXTENDING THE LIFE OF RESIDENTIAL BUILDINGS THROUGH ADAPTATION: A CASE STUDY OF NIŠ, SERBIA

Branislava Stoilković<sup>1</sup>, Hristina Krstić<sup>2</sup>, Nataša Petković<sup>3</sup>, Vladana Petrović<sup>4</sup>

## Abstract

*Circular economy tends to extend the life of products, maximize reuse and recycling, and return all waste material to the production. Since the building sector is one of the main consumers of natural resources and energy, considerable polluters, and substantial producers of waste, it is one of the priority sectors for the application of circular models. Due to the irreplaceable role of architects in the process of creating architectural structures, they are recognized as important bearers of change in the green transition, and it has become clear that circular principles should be incorporated into architectural design as well. Adaptability of buildings is considered one of the most important principles of circular economy in the building sector and one of the key aspects in making housing more sustainable. Through an analysis of selected residential adaptation projects in Niš, Serbia, this paper gives an overview of some possible approaches to housing adaptations, as a model for extending the life of buildings.*

**Key words:** adaptability, housing adaptation, circular economy, architectural design, case study

---

<sup>1</sup> PhD Associate Professor, Faculty of Civil Engineering and Architecture, University of Niš, [branislava.stoiljkovic@gaf.ni.ac.rs](mailto:branislava.stoiljkovic@gaf.ni.ac.rs)

<sup>2</sup> PhD Assistant Professor, Faculty of Civil Engineering and Architecture, University of Niš, [hristina.krstic@gaf.ni.ac.rs](mailto:hristina.krstic@gaf.ni.ac.rs)

<sup>3</sup> PhD Assistant Professor, Faculty of Civil Engineering and Architecture, University of Niš, [natasa.petkovic@gaf.ni.ac.rs](mailto:natasa.petkovic@gaf.ni.ac.rs)

<sup>4</sup> PhD Teaching Assistant, Faculty of Civil Engineering and Architecture, University of Niš, [vladana.petrovic@gaf.ni.ac.rs](mailto:vladana.petrovic@gaf.ni.ac.rs)



## 1. INTRODUCTION

Unlike the linear economy, which is based on the "take-make-dispose" model, the circular economy aims to extend the life of products, maximize reuse and recycling, and return all waste material to the production process. While the linear model implies the persistent consumption of raw materials and energy, processing and use, and finally the continuous production of waste, circular model achieves efficient use of resources, reduction of environmental pollution, financial savings and creation of new business opportunities. The building sector, as one of the main consumers of natural resources and energy, considerable polluters, and substantial producers of waste [1-3], is one of the priority sectors for the application of circular economy business models, due to the potential for improving the economic system in relation to economic and environmental impact. Since architects are important participants in the process of designing and building structures, it is clear that circular principles should be incorporated into architectural design as well [4]. Architect designers, due to their irreplaceable role in the creation of architecture structures, are recognized as important agents of change in the green transition, which, among other things, implies new approaches at the building design scale. One can recognize several important potentials in this area: application of circular design, use of environmentally friendly materials for construction, recycling of demolition and construction waste, etc.

Circular design is one of the key approaches to implementing circular economy in the built environment. The way buildings are designed affects the way they are used, the impact they have on their surroundings and how long they remain fit for purpose. Therefore, the application of circular design strategies for buildings is required, with a special focus on extending the life of buildings [5]. Practices in the design sector that can be applied in the transition to the circular economy include, among other principles, design for flexibility, which implies the use of underutilized space, expansion capacity, demountable partitions and so on [6]. The Ministry of Environmental Protection of the Republic of Serbia in the Roadmap for CE in Serbia [7] proposes a circular model of product life extension for application in the built environment sector; it implies repairs, modifications, or redesign of an existing product, allowing the product to be in use longer, thereby simultaneously extending the life cycle of products and materials.

Adaptability of buildings is considered one of the most important principles of circular economy in the building sector [8]. It prevents premature building demolition by developing a new design culture. Adaptability is one of the key aspects in making housing more sustainable. The application of adaptive design has the potential to reduce environmental impact, as such buildings can be adapted to new needs by reconfiguration, instead of demolition and rebuilding. This kind of design anticipates changes in requirements and enables transformations of the building for better use, reuse, or new ways of using. This means that such buildings are more durable, and longevity can be regarded as an essential condition for environmentally sustainable housing [9, 10].

In today's time of rapid and frequent changes in society, the reversibility and adaptability of residential buildings are becoming one of the main priorities for architects. The personalization of housing has become widespread, and the needs for individualization due to lifestyle changes have recently increased. The periods between changes of purpose, renovation or reconstruction are getting shorter, so it

is increasingly necessary for residential buildings to meet different demands and needs during their lifetime. Architects need to consider several aspects, including functional, structural and aesthetic adaptability. The purpose of this paper is to give an overview of some possible approaches to housing adaptations, taking into account all the above-mentioned aspects.

## 2. METHODOLOGY

Circular building approach has gained considerable attention during the past decade and there is an increasing number of scientific researches dealing with it. It is particularly justified to focus on residential construction, bearing in mind that it represents a significant share in the consumption of material resources, as well as the potential for achieving material efficiency. Moreover, housing adaptation projects, as one of the principles of life-cycle extension of buildings, deserve special attention.

The application of circular design in Serbia is still at a very low level. However, residential building adaptation projects, such as are often realized in Serbia, are examples of projects that deal with extending the life of buildings. Therefore, these projects are examples of good practice in the application of circular economy principles in architectural design and are extremely illustrative for a better understanding of the level (intentional or accidental) of the application of circular models.

In order to analyze and present possible different approaches to the adaptation of residential buildings, the authors conducted a case study, which is an appropriate research design to gain concrete, contextual, in-depth knowledge about a specific real-world subject, and presented selected adaptation projects of residential buildings in Niš, Serbia. The selection of projects was made in such a way that different types of adaptations, different sizes of buildings and different degrees of modification and renovation were represented (alterations of the floor plan, replacement and upgrading of individual components, adding an extension, partial demolitions, remodeling of the facade, energy refurbishment, etc.), bearing in mind that buildings have a residential purpose.

*Table 1. Overview of the selected housing adaptation projects*

No		Architectural studio	Year of construction	Number of floors	Number of units
1	original	/	1935	B+G	1
	adaptation	Teking	2023	B+G+2	1
2	original	/	1938	B+G	1
	adaptation	Alterno	2023	B+G+1	2
3	original	/	1969	G+4	4
	adaptation	Polyarch	2022	G+4	4
4	original	/	1978	G+2	3
	adaptation	Kubik	2021	B+G+2	9

The main criterion for the selection of projects for the case study was to represent both family and multi-family housing buildings, with both keeping the same number of units and increasing the number of units after adaptation, which brings us to the

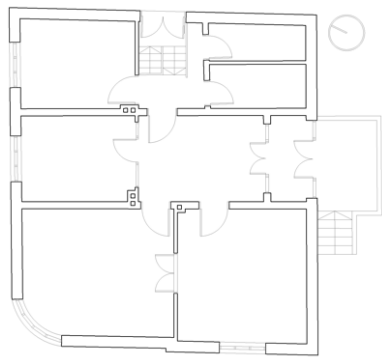
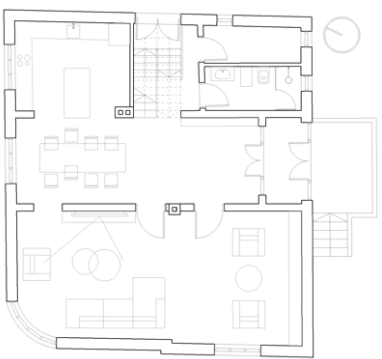
four analyzed projects. The presented adaptations include: adaptation and extension of a family house for the new needs of the old owners, adaptation and extension of a family house with one unit into a building with two residential units, adaptation of a multi-family residential building with the addition of previously unused space and adaptation of a multi-family residential building with three units into a building with nine units. An overview of the selected housing adaptation projects is given in table 1.

### 3. RESULTS

#### 3.1. Project no. 1

The project included the adaptation (with an extension) of a pre-war urban villa for the new needs of the same users in terms of increasing the living space, modernizing the functional characteristics of the unit, and creating a modern building in a visual sense. The existing residential building was built on a traditional masonry construction system with a sloping roof. The facade walls of the existing building were completely preserved, as well as the arrangement of the openings on the facades, while part of the interior walls was demolished in order to connect the rooms and achieve a better functional configuration. The roof structure was removed. An open plan living room was created on the ground floor. The existing floor covering was retained. The structure of the extended part of the building is prefabricated from GLT elements. The facade and partition panels are filled with mineral wool and closed with gypsum-fiber boards, which is a base for further processing on the interior and facade side. The roof of the newly designed part is flat. The plumbing system was improved. The extension is in formal and aesthetic contrast with the existing volume of the ground floor. The use of GLT elements is not very common in the design of residential buildings in Serbia and in this case it was encouraged by the close cooperation between architects and manufacturers. The material left over from the demolition of the walls and roof structure is not reused but is taken to the city landfill. (Table 2)

Table 2. Graphic overview of the adaptation project No 1 (Source: Teking, Niš)

	<i>original</i>	<i>adaptation</i>
<i>Ground floor plan</i>		

First floor plan	X	
3D view		

### 3.2. Project no. 2

The existing building was an old single-family house, built on a traditional masonry construction system with a sloping roof. The new clients, at the same time the architects of this project, planned the construction of two residential units for their own needs through the adaptation and extension. The existing facade walls were kept, while the interior walls were mostly removed (except in the part between the two units) to create an open plan ground floor. The arrangement of the facade openings is adapted to new functional and aesthetic needs. Due to dilapidation, it was necessary to demolish the floor structures above the basement and ground floor and build new ones. The first floor was added over the entire surface of the ground floor, in a brick masonry system. Due to the disrepair and poor quality of the originally installed materials, they were not reused after demolition. The roof above the added floor is flat. The existing facade walls (as well as the new ones) were completely thermally insulated during the renovation. The existing plumbing system was completely replaced with new one due to its poor condition. In terms of aesthetics, the renovated building has a completely different, modern expression. The rubble that remained from the demolition of the walls, floor and roof structure was transported to the city landfill. (Table 3)

Table 3. Graphic overview of the adaptation project No 2 (Source: Alterno, Niš)

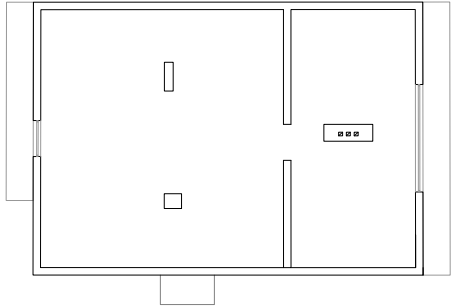

	<i>original</i>	<i>adaptation</i>
<i>Ground floor plan</i>		
<i>First floor plan</i>	X	
<i>3D view</i>		

### 3.3. Project no. 3

This is an adaptation project of a multi-story residential building with four identical apartments on four floors and attic space. The new owners of the building wanted to renovate and modernize the residential units, so that they could sell them more profitably on the real estate market. The project planned to keep the same number of units, and the apartment on the fourth floor became a duplex and the previously unused space in the attic was added to it. The structure of the existing building was made of masonry with horizontal and vertical reinforced bands. The facade and load-bearing internal walls were mainly retained, while the arrangement of the facade openings remained mostly the same. Partition walls were partially demolished for better use of space, obtaining more bedrooms, creating different unit layouts and, in general, better, and more functional configuration. Some rooms, due to their neutrality in terms of shape, dimensions and position within the unit, were easily given another purpose, without the need for demolition and rebuilding (for example:

the living room "moves" into a space with a southern orientation and the bedroom "moves" closer to the second bedroom). Wood flooring was replaced with laminate flooring. The position of the bathroom plumbing systems remained the same, while new plumbing systems were made for the kitchens, in accordance with the new organizational solution. The building has been visually modernized and significantly improved in terms of energy efficiency. All rubble left after the adaptation of the building was transported to the city landfill. (Table 4)

Table 4. Graphic overview of the adaptation project No 3 (Source: Polyarch, Niš)

	<i>original</i>	<i>adaptation</i>
<i>Third floor plan</i>		
<i>Attic plan</i>		
<i>3D view</i>		

### 3.4. Project no. 4

The existing building was initially intended for an extended family consisting of three households, and was built with three identical residential units, one on each floor. After two households moved out, the owners decided to renovate the building to create more small units that can later be sold more easily on the real estate

market. The architects planned three apartments per floor, a total of nine, as well as the extension of the basement floor, which would contain the storage rooms. The structure of the existing building was masonry, and it was completely preserved, while some partition walls were demolished in order to achieve a more optimal unit layout. The position of the facade openings was partially retained. As it was necessary to strengthen the floor structure, the existing floor finish was removed (and completely replaced) and a reinforced screed was poured over the existing slab. Since the existing wooden roof structure was in bad condition, the project planned to replace it. Due to the multiplication of the number of units, it was necessary to install new plumbing systems for bathrooms and kitchens in addition to the existing ones. The facades have been refined, improved and modernized, and the entire building is thermally insulated. The rubble that remained from the demolition of the walls, floor and roof structure was transported to the city landfill and old materials were not reused. (Table 5)

Table 5. Graphic overview of the adaptation project No 4 (Source: Kubik, Niš)

	<i>original</i>	<i>adaptation</i>
<i>Ground floor plan</i>		
<i>Second floor plan</i>		
<i>3D view</i>		

## 4. DISCUSSION

The analysis of selected housing adaptation projects showed several directions of architects' actions, grouped into four categories: functional organization of space, building structure, mechanical, electrical and plumbing (MEP) system and aesthetics of building.

When talking about the functional organization of residential units, it was noticeable that architects predominantly strive to create an open plan living space, regardless of the functional configuration of the existing unit, which often causes the demolition of existing walls. However, if the rooms in the existing unit are neutral (in terms of dimensions, shape, position), they get a new purpose in a newly designed solution, more appropriate to modern housing requirements, without demolishing and/or moving walls. On the other hand, the considerable space fragmentation of the existing units, although inadequate for the application of the open plan principle in larger apartments, favors the division of the initial unit into several smaller ones, which is to a certain extent in line with the current demand on the real estate market. Adding previously unused spaces to the apartment can improve its functional organization and comfort.

The residential buildings selected for the case study were fully built in the traditional masonry system, with or without horizontal and vertical reinforced bands. It was observed that non-bearing, and very often load-bearing brick walls cause a significant obstacle to architects in creating a modern, open plan living space, so they often decide to demolish the existing walls. When demolishing parts of the load-bearing walls, the necessary special reinforcements of the building structure were applied. Although the need to renovate the building is mainly for functional reasons, it has also been used to strengthen or replace certain elements of the structure, which additionally affects the extension of the life of the building. Unfortunately, the reuse of the material left over from the demolition of the walls (as well as the roof structure, floor and wall coverings) was not recorded in the selected projects and all construction waste was transported to the city landfill.

During the renovation of the residential buildings, the architects also retrofitted the existing MEP systems. The reason for this is twofold – the creation of new, different functional configurations of units and the need to improve and renew the existing systems. In any case, this type of renovation contributes to extending the life of the buildings, which is in line with the principles of circular economy.

Adaptations of the buildings included, to a greater or lesser extent, the remodeling of the facades, depending on the architect's idea, the client's requirements, and the available budget. The work of the architects in this segment was related to the aesthetic modernization of the external appearance of the building, but also to the energy refurbishment of the facades, which ultimately contributes to energy savings and is in accordance with circular economy principles. Moreover, the replacement of windows and balcony doors contributes to a visual-aesthetic improvement, as well as an increase in energy efficiency.



## 5. CONCLUSION

The analysis of selected examples allowed the authors to draw several key lessons regarding residential adaptation projects. They relate to functional, structural and aesthetic adaptability.

The functioning of a modern household requires a modern approach to solving unit plan configuration. The considerable division of living space usually does not correspond to modern housing needs, as well as the open plan design principle. Therefore, demolishing partition walls and connecting rooms is a common choice. However, as there is still considerable demand for smaller apartments in the real estate market, dividing existing units into several smaller ones is also a common solution. In this case, it is most often necessary to additionally partition the units, as well as introduce new MEP systems. Furthermore, designing apartments with identical plan configurations on all floors in today's time of pronounced pluralism in society proves to be unsuitable. When changing the users of the residential unit, but also when the needs of the existing users change over time, the flexibility of the space is obviously a very desirable characteristic, because it enables modifiability and different ways of using the space. Giving unused or underused spaces a new (residential) purpose can contribute to realizing the full potential of space which is in line with the principles of the circular economy.

It was observed that the lower the quality of the existing structure, the greater the extent of demolition. What is particularly worrying is the fact that the analyzed projects did not consider the reuse of the material left over from the demolition (bricks from demolished walls, elements of the removed wooden roof structure, floor-, wall- and ceiling coverings...). As expected, all construction waste was taken to city landfills where it was mixed with other waste, since there is no landfill for construction waste in Serbia. This is exactly the aspect that needs to be significantly improved in future renovations of residential buildings.

When the building has a certain historical value, architects often decide to completely keep the existing facades, and to leave a mark on the extension. Otherwise, the architect's ideas about the aesthetic modernization of the facades were accepted in accordance with the budget.

The concept of adaptive housing has always been associated with the building's ability to respond to changing demand. It is necessary that housing can adapt to changing market conditions and different users' requirements. From the perspective of extending the life span of residential buildings, they should be designed and constructed to easily adjust to the evolving lifestyle of their residents or to different lifestyles of new ones. This could be done either by facilitating the continuation of the intended use or through possible future changes in use.

## REFERENCES

- [1] Askar Rand, Bragança Luís, Gervásio Helena: Design for Adaptability (DfA)— Frameworks and Assessment Models for Enhanced Circularity in Buildings. *Applied System Innovation*, 5, 24, 2022.
- [2] Malabi Eberhardt Leonora Charlotte, van Stijn Anne, Kristensen Stranddorf Liv, Birkved Morten, Birgisdottir Harpa: **Environmental Design Guidelines for Circular Building Components: The Case of the Circular Building Structure**. *Sustainability*, 13, 5621, 2021.

- [3] Çetin Sultan, Gruis Vincent, Straub Ad: Towards Circular Social Housing: An Exploration of Practices, Barriers, and Enablers. *Sustainability*, 13, 2100, 2021.
- [4] Stoiljković Branislava, Petković Nataša, Krstić Hristina, Petrović Vladana: **Application of Circular Economy Principles to Architectural Design: A Case Study of Serbia.** *Buildings*, 13, 2023.
- [5] Ellen MacArthur Foundation: Cities in the Circular Economy: An Initial Exploration. 2017
- [6] <https://www.ceguide.org/Strategies-and-examples> (2.5.2023.)
- [7] <https://circulareconomy.europa.eu/platform/sites/default/files/roadmap-for-circular-economy-in-serbia.pdf> (5.5.2023.)
- [8] European Commission: Circular Economy Principles for Building Design. 2020.
- [9] Zairul Mohd, Geraedts Rob: **New business model of flexible housing and circular economy.** *The Future of Open Building Conference*, Zurich, Switzerland, September 9-11, 2015.
- [10] Tarpio Jyrki, Huuhka Satu, Vestergaard Inge: **Barriers to implementing adaptable housing: architects' perceptions in Finland and Denmark.** *Journal of Housing and the Built Environment*, 37, 1859–1881, 2022.

## RIVER TRAINING WORKS WITH THE AIM OF FLUVIAL PROCESSES CONTROL THROUGH THE SEDIMENT TRANSPORT AND DEFORMATION OF THE RIVER BED ANALYSIS

Aleksandra Ilić<sup>1</sup>, Ilija Ilić<sup>2</sup>, Dragan Radivojević<sup>3</sup>, Borko Radivojević<sup>4</sup>

### Abstract

*The flow in open channels is complex, spatial and depends on various natural factors (hydrological, meteorological, geological, psamological, hydraulic and morphological), but also on human actions both in the bed itself and in the basin. Then, due to intensive erosion processes, the transport capacity of the watercourse in terms of total sediment is often exceeded. As a result, deformation of the riverbed, erosion or deposition occurs, which depends on the sediment load that arrives and the response of the watercourse to that load.*

*The paper presents a coupled hydraulic and psamological model created using the HEC-RAS software, which enables the assessment of the transport capacity, erosion and local scour. The mean perennial flood wave were derived which were then fed into HEC - RAS to model processes in the river catchment.*

*Based on the results of the calculation, a concept for the river bed training is proposed in order to stabilize it and prevent a significant change in the morphology of the surrounding and downstream area. The analyses are carried out on a part of the Western Morava river basin in Serbia.*

**Key words:** *unsteady flow, sediment transport, riverbed deformation, river engineering, HEC-RAS*

---

<sup>1</sup> Dr., Assistant Professor, Faculty of Civil Engineering and Architecture Niš, aleksandra.ilic@gaf.ni.ac.rs

<sup>2</sup> MSc, Student, Faculty of Civil Engineering and Architecture, ilija20ilic@gmail.com

<sup>3</sup> Dr., Assistant Professor, Faculty of Civil Engineering and Architecture Niš, dragan.radivojevic@gaf.ni.ac.rs

<sup>4</sup> MSc, PhD candidate, Faculty of Civil Engineering and Architecture, borko.radivojevic@yahoo.com

## 1. INTRODUCTION

The basic characteristic of the flow in open channels is that contains a certain amount of alluvial formations, which depends on the geomorphological, hydrological and meteorological characteristics of the catchment area. As a result of heavy rains or due to sudden melting of snow, high intensity surface runoff is formed, which leads to the movement of material from the slopes into the hydrographic network, where a large amount of water and a torrent are quickly created. Floods occur every year and sometimes several times during the year. They occur simultaneously on one or more streams. In their work, Petković and Ljuljić [1] showed that sediment transport does not depend on the total annual inflow in that basin, but on the structure of the inflow from the number and size of torrential waves that carry large amounts of sediment.

In order to predict the behavior of the river, the response to the amount of sediment produced, processes should be observed starting from the catchment level down to the sediment grain [2]. Erosive processes on the one hand and deposition of materials on the other have a limiting role in spatial planning, but also a positive role in terms of the production of materials that are only used in construction [3]. Engineers are particularly interested in this aspect of water management because it leads to the destabilization of already built embankments and bridges, increasing the risk of floods and changing ecological conditions both in the riverbed itself and in the basin [4].

Changes in the morphology of the riverbed can be detected and quantified by field investigations and then by numerical simulations based on measurements. Model accuracy, as pointed out by Lazović and Hadžić [5], among others, is certainly affected by the quality of the measurements.

The construction of hydrotechnical facilities implies an assessment of the trend of deformation of the riverbed and the influence of the distribution of alluvial formations on the selected river reach. Determining the transport capacity of watercourses for sediment, the nature and morphological characteristics enables easier river training works [6].

There are a large number of theoretical and empirical methods for calculating the transport of bed and total sediment, and the selection of an adequate method is a significant problem in the calculation of the riverbed deformation [7], [8]. The explanation lies in that it is difficult to carry out sediment transport measurements, especially in natural watercourses, so it is completely impossible to predict the exact amount of total sediment [9].

## 2. STUDY AREA AND INPUT DATA

### 2.1. The West Morava River Reach from the mouth of the Ibar to the HS Miločaj

In this paper, the reach of the West Morava River from the mouth of the Ibar River to hydrological station (HS) Miločaj. It belongs to the so-called the upper basin of the West Morava and in a geographical sense this area includes the southwestern parts of Šumadija, western part of Pomoravlje, the northeastern parts of the The Stari Vlah-Raška Mountain as well as the Valjevska Podgorina (Figure 1).

In the geomorphological sense, the studied area belongs to terrains with dominant genetic and morphological relief diversity. It is conditioned by the existence of different geological formations: from clastic, organic and chemical sediments, to metamorphic rocks, as well as different groups of magmatites. Biogeographic diversity is conditioned by the existence of forest communities, grassy vegetation and agricultural crops. Different hydrogeological conditions and phenomena are also observed [3]. The observed terrain is characterized by heterogeneity in relief and geological conditions. The physical-geographical factors of the terrain impact the intensity of erosive-accumulative processes, and this is their importance.

## **2.2. Geological data**

The geometry of the selected (Figure 1) was completed on the basis of measurements from 2006 [10] by introducing all additional changes in accordance with the changes both in the riverbed and in the documentation [11]. A total of 97 cross profiles were recorded at an average distance of 500 m for the purpose of creating a digital model of the terrain (DMT) during document [10] design. All recorded cross profiles were prepared in the form of a series of points with data on the position of the points (x, y, z coordinates) in the national coordinate system, as well as the river axis and its position in space.

These data were embedded in the DMT, which was clipped from the DMT of Serbia at 25m [11].

In this way, a universal digital model of catchment and riverbed was formed, which served to expand the cross profiles, first for hydraulic, and then for psamological calculations.

## **2.3. Logical data**

The input parameter in the coupled model is the flood hydrograph. In this paper, the results of the hydrological analysis for the Western Morava basin were used, namely the statistical analysis of the maximum annual flows for the period 1955-2018 and the analysis of the shape of the runoff hydrograph and the volume of flood waves [12].

Figure 2 shows the hydrograph of the mean perennial flood wave, which was used as the upstream boundary condition in the model.

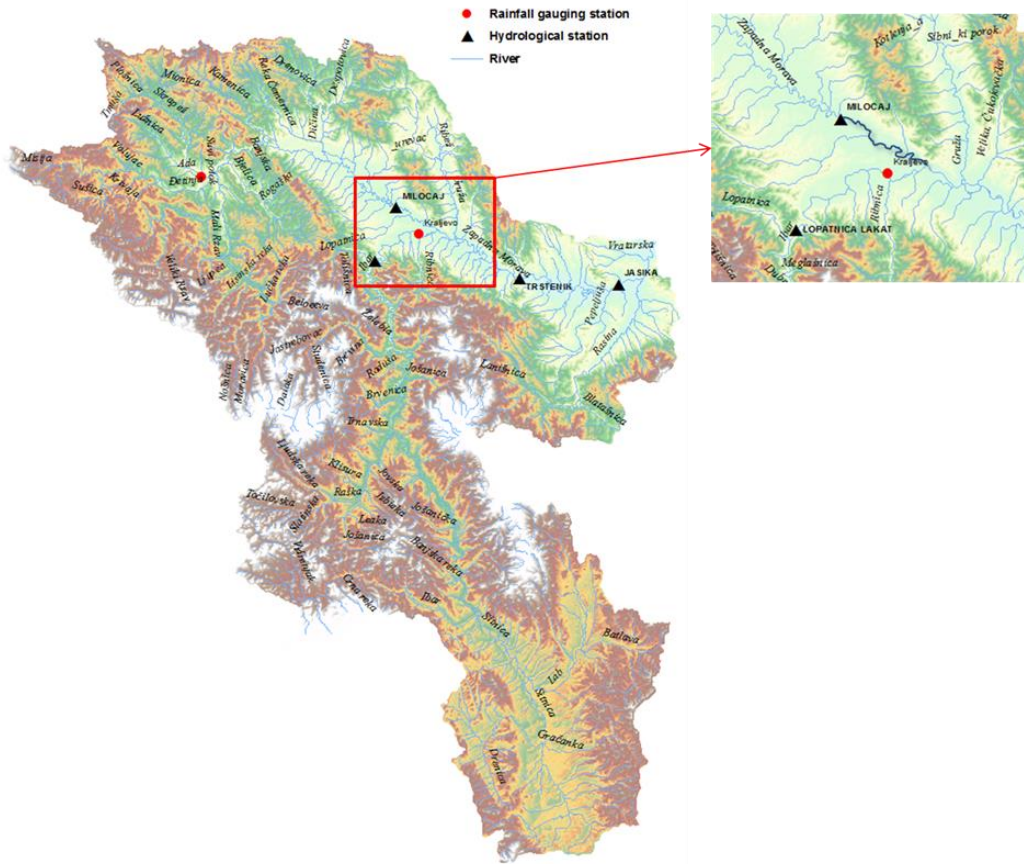


Figure 1. The West Morava River catchment

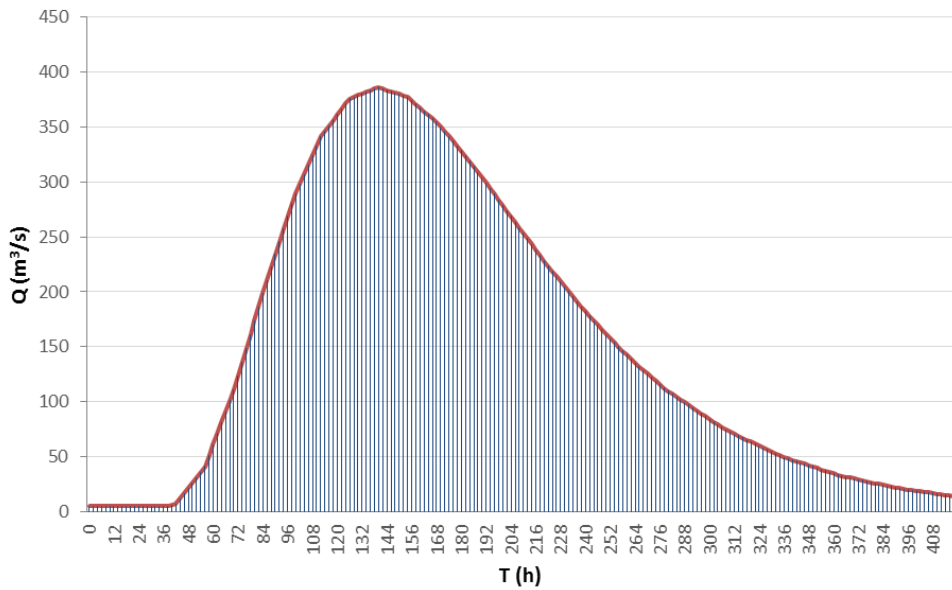


Figure 2. The mean perennial flood wave at HS Miločaj

## 2.4. Psamological data

The work program for the General Design [10], from the mouth of the Great Morava to the mouth of Moravica and Đetinja, provided 60 sediment samples from the bottom, as well as their granulometric analysis. Sediment samples were not taken from HP Međuvršje and Ovčar banja reservoirs. The granulometric curves thus formed on the considered sector of the Western Morava, from the mouth of the Ibar to HS Miločaj) show the heterogeneous structure of the riverbed and it is obvious that gravel and coarse sand represent the basic granulometric components of all samples. Considering the position and granulometric composition of the material from the affected samples, it can be concluded that the bed of the Western Morava has a uniform composition. The  $d_{50}$  grain diameter ranges from 11.57 to 21.69 mm, while the  $d_{90}$  grain diameter ranges from 25.27 to 75.95 mm.

Figure 3 shows seven granulometric curves that were entered into the model by sampling stations along the riverbed from [10].

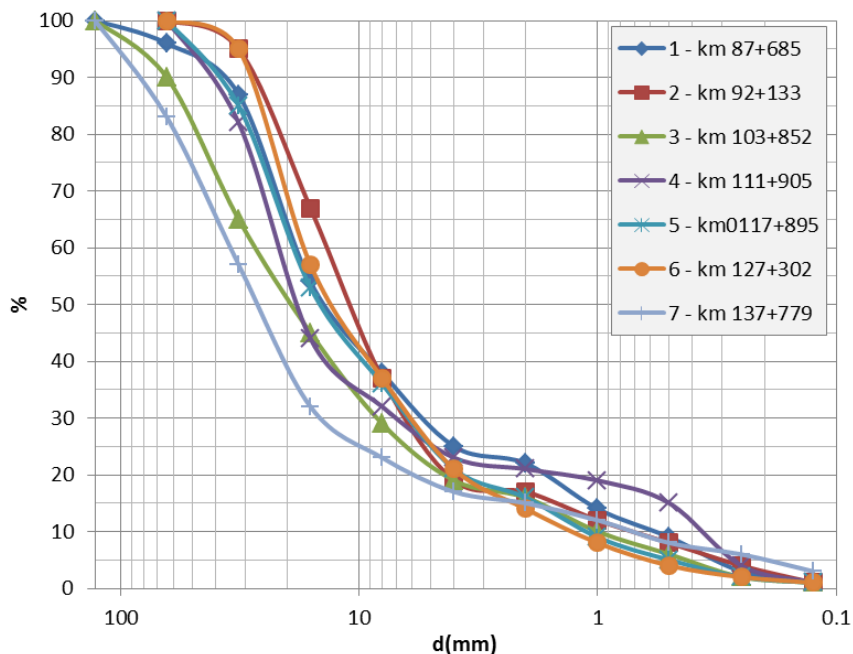


Figure 3. Granulometric curves by sampling stations along the riverbed from [10]

## 3. METHODOLOGY

### 3.1. HEC-RAS model

Sediment can be modeled in HEC-RAS software since version 5.0. The model created in this way consists of a series of components that are shown in Figure 4.

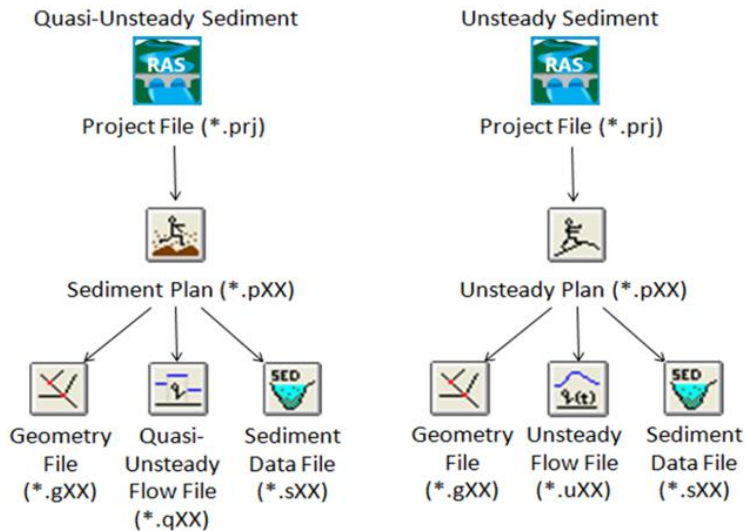


Figure 4. Two approaches to structuring sediment models in HEC-RAS [13]

This model can be based on two approaches, quasi-stationary and unsteady flow. A quasi-steady hydrodynamic model is considered default [14] and allows simulation under steady flow conditions in a given time frame set for the river sediment transport function.

Creating a non-stationary hydrodynamic model requires modeling skill because significant instabilities can occur due to the fixed-bottom model. When solving the Saint Venant equation, an even greater instability of the model occurs due to deformations of the riverbed. Its main advantage is in the conservation of flow for volume change, which is dominance in reservoir design.

### 3.1.1. Geometry model

For each sediment transport model, the geometry of the hydraulic model is used, but it must be modified in the sense that the sediment calculation introduces additional instability because we have active layer concept.

In terms of creating representative cross sections, the number of points should be selected as desired, a maximum of 60 pairs of stations, elevation (x,y), for which there is a special tool (Cross Section Point Filter).

### 3.1.2. Hydraulic model

Unsteady flow is characterized by variability of hydraulic parameters (flow, water level, speed) in space and time [13]. Basic equations for linear, unsteady flow in open channels are Saint Venant equations:

1. Mass conservation equation (equation of continuity):

$$\frac{\partial A}{\partial t} + \frac{\partial Q}{\partial x} = 0 \quad (1)$$

2. Equation of conservation of momentum - dynamic equation:



$$\frac{\partial Q}{\partial t} + \frac{\partial}{\partial x} \left( \frac{Q^2}{A} \right) + g \cdot A \frac{\partial Z}{\partial x} + g \cdot A \cdot I_e = 0 \quad (2)$$

Where:  $Q$  – flow,  $A$ - surface area of the flow profile,  $I_e$  – friction slope.

The Saint Venant equations are partial differential equations of the hyperbolic type, which cannot be solved in the general case. By introduction of approximations these equations could be used for the calculation of water levels in open channels under unsteady conditions.

To solve them, it is necessary to set initial and boundary conditions. The initial conditions are the values of the variables along the channel at the initial moment of time ( $t_0$ ). They are obtained by hydraulic calculation of steady flow for the initial flow value  $Q(t_0)$ .

Boundary conditions are:

- External – defined at the profiles at the upstream and downstream end of the calculation reach. At the upstream end, a hydrograph or graph of water levels can be specified, and at the downstream end a hydrograph, level graph or flow curve.
- Internal ones are given at profiles where there is an estuary, a dam, side overflow etc.

### 3.1.3. Psamological model

The psamological model in HEC-RAS includes several steps and many settings for easier calibration and verification.

The first step is to enter the initial conditions and parameters for the selected transport function. The following transport functions can be selected in this editor: Engelund-Hansen, Laursen (Copeland), Yang, Mayer-Peter-Muller (MPM), Toffaleti, MPM-Toffaleti, Yang and Wilcock-Crowe. Sorting Method can be: Thomas (Ex5), Active layer, Copeland (Ex7). Offered fall velocity methods are Rubey, Toffaleti, Van Rijn, Report 12, Dietrich, Soulsby, Wu and Wang. [13], [15].

During the initial setting of the model, the assumed depth of erosion (Max Depth) and limits in the river bed within which deformation of the bed is expected (Left and Right Movable Bed Limits) should be entered.

Also, the available granulometric curves of the soil that correspond to the set cross profiles should be entered.

The transport potential represents the possibility of moving a certain amount of sediment in response to hydraulic parameters in the cross section of the open channel. In HEC-RAS, it is determined for each sediment grain. The essence of transport functions lies in the fact that they convert hydrodynamic parameters into transport.

For solving practical engineering tasks, the Engelund-Hansen [16] formula seems to be the most appropriate [9]. The equation for the calculation of the total sediment resulting from the flow test in the channel using a uniform sediment composition of 0.19 mm to 0.93 mm. This formula is usually used for sandy terrain and is not recommended for particles smaller than 0.15 mm.

$$g_s = V^2 \left( \frac{\tau}{(\gamma_s - \gamma)d_{50}} \right)^{3/2} \sqrt{g \left( \frac{\gamma_s}{\gamma} - 1 \right)} = V^2 (\tau^*)^{3/2} \sqrt{g \left( \frac{\gamma_s}{\gamma} - 1 \right)} \quad (3)$$

Where:

$g_s$  – unit sediment transport (kg/sm');  
 $\gamma$  – specific weight of water (N/m<sup>3</sup>);  
 $\gamma_s$  – specific weight of sediment (N/m<sup>3</sup>);  
 $\tau$  – shear stress (N/m<sup>2</sup>);  
 $\tau^*$  – Shields number (N/m<sup>2</sup>).

Yang [17], [18] formulated an equation for total sediment transport based on flow "power" (dissipation of potential energy over the length of the open channel) equal to the product of velocity and shear stress. It was developed on a set of data, both from the channel and from the open stream.

Equation [17] refers to sands ( $d < 2\text{mm}$ ):

$$\log C_t = 5.435 - 0.286 \log \frac{\omega d_m}{\nu} - 0.457 \log \frac{u^*}{\omega} + \left( 1.799 - 0.409 \frac{\omega d_m}{\nu} - 0.314 \log \frac{u^*}{\omega} \right) \log \left( \frac{VS}{\omega} - \frac{V_{cr} S}{\omega} \right) \quad (4)$$

Where:

$C_t$  – total sediment concentration (ppm);  
 $\omega$  – the fall velocity (m/s);  
 $d_m$  – design sediment grain (m);  
 $\nu$  – kinematic coefficient of viscosity (m<sup>2</sup>/s);  
 $u^*$  – shear velocity (m/s);  
 $V$  – mean flow speed (m/s);  
 $S$  – energy slope (m/m').

This function was modified in 1984 for sediment with  $d > 2\text{mm}$  [18]:

$$\log C_t = 6.681 - 0.633 \log \frac{\omega d_m}{\nu} - 0.282 \log \frac{u_s}{\omega} + \left( 2.784 - 0.305 \frac{\omega d_m}{\nu} - 0.282 \log \frac{u_s}{\omega} \right) \log \left( \frac{VS}{\omega} - \frac{V_{cr} S}{\omega} \right) \quad (5)$$

Where  $V_{cr} = 2.05\omega$ , speed at the beginning of flow (m/s).

The unit sediment transport is equal to:

$$g_s = 0.01 C_t V H \quad (6)$$

where  $g_s$  is in (kg/cm').

Regarding the choice of method for the calculation of the fall velocity (Fall Velocity setup), it was shown that psamological models do not show sensitivity to the choice of method (Toffaletti, Van Rijn, Soulsby, Rubey, Report 12, Dietrich, Wu and Wang) [14]. The method of Toffaletti [19] is used in the paper.

One should be careful using transport functions defined in this way in model of unsteady flow. What could be the influence of the vertical velocity caused by the non-stationarity [20]?

HEC-RAS automatically sets the external boundary conditions, when creating the psamological model, internal ones should be set manually. There are several options for setting boundary conditions. In this paper "equilibrium load" is used due to the lack of the amount and concentration of sediment data arriving from the upstream sections. As well as setting the downstream boundary condition by normal depth, equilibrium load is popular because it is simple and in this way avoids the robust pre-processing that is done when forming the sediment rating curve. The rating curve could be set on the upstream boundary profile, where the amount of sediment is set based on the soil composition and transport capacity. Additionally, data on deposition rates are usually scattered. Seasonality, non-stationarity, hysteresis, sampling errors and random processes create difficulties in creating unique flow-sediment dependence. An advanced step for future research is to adopt any curve that can be calibrated based on observed deformations.

#### 4. RESULTS AND DISCUSSION

The method of setting the model in HEC-RAS and the selection of parameters is shown in Table 1.

*Tabela 1. Categories, parameters and input data in coupled model in HEC-RAS*

<i>Category</i>	<i>Parameters and input data</i>
<i>Flow</i>	<ol style="list-style-type: none"> <li>1. Unsteady flow;</li> <li>2. Upstream boundary condition: Mean maximum perannual flow hydrograph at HS Miločaj;</li> <li>3. Downstream boundary condition: Normal depth.</li> </ol>
<i>Bed sediment</i>	<ol style="list-style-type: none"> <li>1. Grain size distributions (Institut „Jaroslav Černi“, 2007): seven specific</li> </ol>
<i>Sediment transport and deposition</i>	<ol style="list-style-type: none"> <li>1. <i>Upstream boundary condition: equilibrium flow</i></li> <li>2. <i>Cohesive content and transport: do not considered separately</i></li> <li>3. <i>Bed mobility: at bank stations defined by cross-sectional geometries (calibrated)</i></li> </ol>
<i>Sediment sorting</i>	<ol style="list-style-type: none"> <li>1. Active layer sorting method</li> </ol>
<i>Fall velocity</i>	<ol style="list-style-type: none"> <li>1. Toffaleti</li> </ol>

The model was calibrated by comparing the model results with the measured data from the [10]. The points for the boundary of the movable bed were determined first at the points of the beginning of flow in inundations (Banks), and then the points were moved towards the foot of the main channel.

Figure 5 shows the calculation results and measured data on the thalweg from 1961 and 2016 [10]. It can be seen that the best agreement with the measured data is obtained using the Engelund-Hansen transport function. The simulation is the most stable, and the calculation could not be completed when moving the movable bed points. The Yang transport function gives a good agreement with the fact that moving the movable bed limits causes accumulation in the tributary zone, which is theoretically justified, but does not correspond to the recorded situation. It can also be seen that in the area of the mouth of the Musina river, the model detects an erosive process after 2020, which may indicate anthropogenic influence in the riverbed.

Compared to measurements from 1961, the observed section of the West Morava River shows certain erosion potential, except in the tributary zones, due to the certain amount of sediment inflow. Some important differences in the thalweg line between the recordings in 2007 [10] and 2016 [21] were not observed.

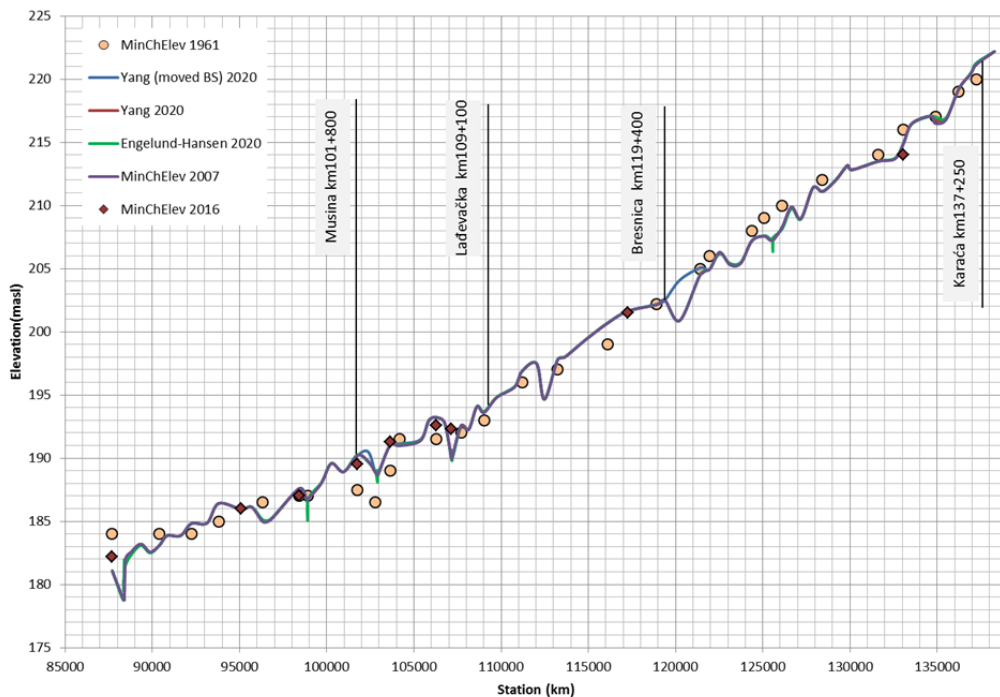


Figure 5. Comparative presentation of the simulated and measured thalweg lines on the West Morava River reach from the mouth of the Ibar to HS Miločaj

## 5. CONCLUSION

The main characteristic of the morphological processes in the Western Morava is the meandering and wandering of the riverbed [10]. Both of these processes take place as a consequence of fluvial erosion. The dynamics of morphological changes is a consequence of fluctuations in water and sediment inflow from the catchment area and the ratio of water flow and sediment transport. Changes in the ratio of flow and sediment transport are not only influenced by natural factors, but also by anthropogenic action. River training facilities such as revetments, transverse

structures on the one side, and cuts off meander and dragging on the other aimed at stabilizing the riverbed and maintaining the flow profile can significantly improve the current picture, but also affect the reduction of the risk of flooding in the surrounding area. Such works must be designed and carried out under the control of authorized professionals so that they do not cause more harm than good.

Based on the results of the calculations, it can be seen that the biggest changes in the riverbed occurred in the period 1961-2007. for the reason that the reservoirs of HE Međuvršje and Ovčar banja were built at that time, which play a major role in reducing the amount of sediment in the catchment. In the period after 2016, there were no significant changes, but it is emphasized that the influence of the constructed highway E-761 [21] and the facilities in its function may accelerate changes in the near future. A complete picture can only be obtained through detailed field investigations. Modern measuring devices and investments in the establishment of a network of sediment measurement would certainly help in eliminating the uncertainties faced by the professionals when assessing sediment transport processes and designing hydrotechnical facilities.

## REFERENCES

- [1] Petković Slobodan, Ljuljić Milanko: **Sedimentation of small reservoir on a torrent stream**, *Voda i sanitarna tehnika*, XL(2) 31-46, 2010.
- [2] Coleman E. Stephen, Smart M. Graeme: **Fluvial sediment-transport processes and morphology**, *Journal of Hydrology (New Zealand)*, Vol. 50, No. 1, Special Issue: Sediment flux, Morphology and River management (June 2011), pp. 37-58, 2011.
- [3] Nikolić Jugoslav, Nikolić Milena, Nikolić Đorđe: The study of the natural characteristics of the basin as a function of forecasting erosion and the deposition processes on the example of the selected basin, *J. Geogr. Inst. Cvijic* 62(2), p. 15-32, 2012.
- [4] Stéphane Rodrigues, Florentina Moatar, Nicolas Claude: **Sediment transport**, 2013. <https://doi.org/10.1002/9780470057339.vas010.pub2>
- [5] Lazović Nerma, HaDžić Emina: **Odabir metode za pronos nanosa u proračunu opšte deformacije reke Željeznice**, VODOPRIVREDA, 0350-0519, Vol. 50, No. 291-293, p.145-155, 2018.
- [6] Joshi Neekita, Lamichhane Raj Gaurav, Rahaman Mafuzur Md., Kalra Ajay, Ahmad Sajjad: **Application of HEC-RAS to Study the Sediment Transport Characteristics of Maumee River in Ohio**, *World Environmental and Water Resources Congress*, 2019.
- [7] Jovanović Miodrag: **Regulacija reka**, Građevinski fakultet Univerziteta u Beogradu, Beograd, 2008.
- [8] Babić Mladenović Marina: **Uređenje vodotoka**, *Institut za vodoprivredu „Jaroslav Černi“*, Beograd, 2018. (In Serbian)
- [9] Sulaiman Olewi Sadeq, Al-Ansari Nadhir, Shahadha Ahmed, Ismaeel Rasha, Sura Mohammad: **Evaluation of sediment transport empirical equations: case study of the Euphrates River West Iraq**, *Arabian Journal of Geosciences*, 14:825, 2021. <https://doi.org/10.1007/s12517-021-07177-1>
- [10] Institut za vodoprivredu „Jaroslav Černi“: **Generalni projekat uređenja Zapadne Morave**, 2008.
- [11] Safege SUEZ – IPF6 Consortium, 2019, Serbia: **West Morava and Tamis Subriver Basins, Infrastructure Programme for Integrated Water management**, Beneficiary State Public Utility Srbijavode: Sub/project WB18-

- SRB-ENV-02, General Technical Design for the Catchment of the Zapadna Morava river with all 36 Tributaries, Steady & Unsteady Flow Simulation, Flood Risk Mapping and Analysis, Conceptual Design for Flood Risk Control; Integral water management and habitats protection on the area of the Pančevački Rit, 2019.
- [12] Prohaska Stevan, Bartoš Divac Vladislava, Ilić Aleksandra: **Velike vode Srbije na profilima hidroloških stanica**, Institut za vodoprivredu „Jaroslav Černi“ i RHMZ Srbije, Beograd, str. 529, 2020.
- [13] USACE Hydrologic Engineering Center: **1D Sediment Transport Technical Reference**, v. 6.0, 2023.
- [14] Haschenburger J., K., Curran Joanna: **Sediment Transport Modeling of Reach Scale Geomorphic Processes**, Final Report for TWDB Contract No 0904830899, 2012.
- [15] USACE Hydrologic Engineering Center: **1D Sediment Transport User's Manual**, v. 6.0, 2023.
- [16] Engelund Frank, Hansen Eggert: **A monograph on sediment transport in alluvial streams**, *Technical University of Denmark*, Copenhagen, 1967.
- [17] Yang C. T.: **Incipient Motion and Sediment Transport**, *Journal of the Hydraulics Division*, Vol. 99, No. 10, pp. 1679-1704, 1973.
- [18] Yang C. T.: **Unit stream power equation for gravel**, *Journal of Hydraulic Engineering*, ASCE 110(12), p. 1783-1797, 1984.
- [19] Toffaleti, F.B.: **A Procedure for computation of total river sand discharge and detailed distribution, bed to surface**, Technical Report No. 5, Committee on Channel Stabilization, *U.S. Army Corps of Engineers*, 1968.
- [20] Yang Shu-Qing: **Formulae of Sediment Transport in Unsteady Flows (Part 2)**, <https://dx.doi.org/10.5772/intechopen.94761>
- [21] Institut za vodoprivredu „Jaroslav Černi“: **Hidrotehnička studija koridora autoputa E-761 deonica Pojate – Preljina**, Beograd, *Beneficiary State Public Utility Putevi Srbije*, 2016.

# ANALYSIS OF THE INTERACTION BETWEEN THE FOUNDATION SLAB AND THE SOIL IN A MULTI-STOREY REINFORCED CONCRETE BUILDING

Marijana Janićijević<sup>1</sup>, Stefan Mihajlović<sup>2</sup>

## Abstract

*Analysis of the interaction between the foundation soil and the structure is a very important aspect of aseismic design. During the action of an earthquake, seismic waves deform the underlying soil, transferring stresses to the structure. Soil-structure interaction is a concept that refers to the building structure, the foundation structure, and the geological environment in which the foundation structure is located. Understanding the interaction process can, in some cases, reduce the intensity of the forces acting on the structure, mostly by damping and extending the period of vibration of the structure.*

*This paper presents an analysis of the interaction between the foundation slab and the soil using a model of a reinforced concrete building with Bsmt+GF+4 floors. The construction of the building is skeletal - it consists of reinforced concrete frames with a distance of 5 m in two orthogonal directions. The reinforced concrete elements have the same cross-section on all floors. The soil under the foundation slab is modeled as a half-space, which implies representing the soil volumetrically, using volumetric finite elements with appropriate properties. In this type of modeling, the soil is described by two parameters: the type of soil is determined by the deformation modulus and Poisson's ratio. The analysis shows the dependence of the static influences on the thickness of the foundation slab and the size of the finite elements for three different values of the soil deformation modulus. The software package TOWER 8 was used for modeling, design and calculation of the effect of all structural reinforced concrete elements, applying the European standards - Eurocodes.*

**Key words:** *soil structure interaction, seismic action, static influences, soil parameters*

---

<sup>1</sup> Ass., MSc, PhD student, University of Kragujevac, Faculty of Mechanical and Civil Engineering in Kraljevo, janicijevic.m@mfkv.kg.ac.rs

<sup>2</sup> Ass., MSc, PhD student, University of Kragujevac, Faculty of Mechanical and Civil Engineering in Kraljevo, mihajlovic.s@mfkv.kg.ac.rs

## 1. INTRODUCTION

The interaction between the foundation slab and the underlying soil is a critical aspect of civil engineering [1]. The actual behavior of the structure under seismic action requires modeling of the interaction between the structure and the underlying soil (SSI -soil structure interaction), which introduces the flexibility of the foundation structure and soil into the analysis. The effects on the structure during earthquake action depend on the interaction of three interrelated systems: the structure itself, the foundation structure, and the geologic subsoil on which the foundation structure is located [2]. This means that the behavior of the foundation soil affects the construction and vice versa. Therefore, it is important to combine knowledge of geophysics, civil engineering, and geotechnical engineering to make the analysis of the interaction as high quality as possible [1]. When seismic waves propagate through the soil without foreign bodies, the soil behaves in a certain way, but when a foreign body (foundation structure) with a certain stiffness is found in that soil, the soil changes its behavior depending on the properties of the structure (Figure 1).

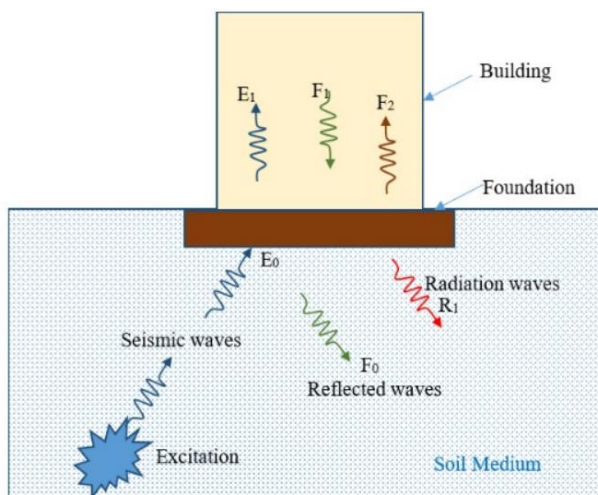


Figure 1. Soil structure interaction effect and wave propagation [3]

The interaction between the structure, the foundation, and the underlying soil can have significant effects on the behavior of each of these elements, as well as on the general behavior of the entire system. For example, the relative stiffness of the structure, its subgrade, and the underlying soil will affect stresses and displacements, both in the structure and in the underlying soil [4].

Two basic factors that characterize the mutual influence of the building and the ground under the structure are deformations of the soil from loads that are transferred from the structure to the ground through the foundation and the ability of the structure to follow the soil deformations. With the use of various types of soil for supporting the foundation, the need to include the effects resulting from soil deformation in the calculation of the construction of the building is becoming more and more frequent. The magnitude of such influences in the structure depends on the stiffness of the structure. As a consequence of soil deformation under the building, subsidence, horizontal movement, and rotation of the foundation of the building occur. For absolutely rigid structures, the amount of rotation is very important, both for the foundation and for the object as a whole. In the case of



absolutely flexible structures, the average amount of settlement is important in order to evaluate the changes that may occur during the exploitation of the structure. When calculating structures of finite stiffness, soil deformations should also be taken into account. In this calculation, the structure should be considered together with the soil, taking into account the mutual influence of the structure and the soil, which represents a very complex problem. It should be emphasized that there are methods that allow the calculation to include the mutual influences of the structure and the soil. Therefore, deformations of the soil under the foundation under the influence of external loads are particularly significant for the evaluation of the behavior of the structure during exploitation. Its safety and exploitability depend on the amount of deformation of the soil under the foundation of the structure [5]. Computational models for the calculation of the complete soil-structure interaction in different cases and combinations of loads that occur during construction and during the use of the structure are very complex, extensive, and demanding task that is rarely fully implemented in practice. Simplifications of calculation models and calculations are very common in order to make the problem simpler and practically predictable [6].

It has been proven that SSI can affect aspects related to the seismic performance of a building such as energy dissipation, strength, and ductility. In some cases, the capacity of the structure can be overestimated if the SSI analysis is omitted, resulting in unreliable results [7].

## **2. METHODOLOGY**

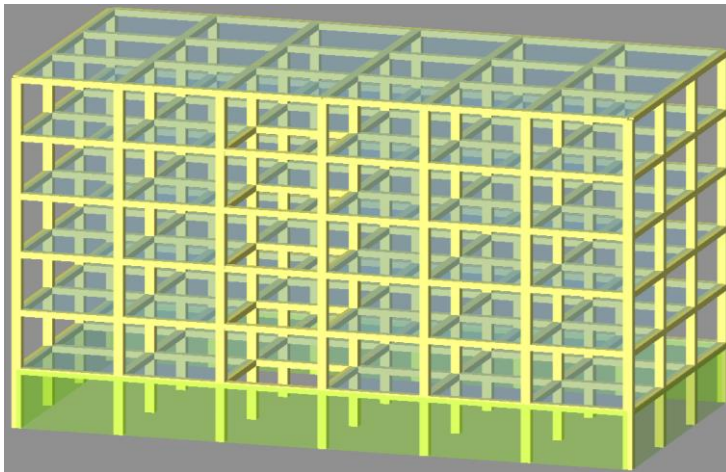
Solutions to problems between deformable bodies have a very wide application in many engineering disciplines, but they can only be obtained by applying very complex numerical methods. The simplest solutions describe the combination of linearly elastic and ideally rigid bodies, and for such problems, the solution can be obtained in an analytical form. However, in the case of practical problems that are usually quite complex, even when the simplest linear elastic model is used, the solution to the problem can be obtained by approximate, that is numerical methods. In order to obtain realistic results of construction calculations, it is necessary, among other things, to solve the interaction of the object with the foundation and the soil during all phases of the construction of the object. Given that the mechanical properties of the soil are very complex, the solution to the problem of the interaction of the foundation soil with the structural elements requires certain simplifications, which approximate the real state with a computational model. Without such simplifications, the problem would be insoluble. The level of simplification must be such that it excludes features that do not affect or very little the final result while retaining the essential mechanical characteristics of the structure and soil. More complex material models, if properly applied, give more realistic results on the basis of which it is possible to design and build more rationally. However, their application is not always necessary or justified [8]. When creating a model for static stress, the soil is an infinite space with an unbounded domain. Therefore, for such an analysis, a fictitious boundary is taken that is far enough from the structure that the stress effect stops at that boundary [9].

There are two methods to deal with the interaction between the foundation soil and the structure, direct and indirect. A direct method is an approach in which the entire structure is analyzed as a whole using computer software, while the indirect

method first analyzes the inertial and kinematic interactions separately, after which these interactions are added together to obtain the overall analysis. The direct method uses the finite element method, it is more complex than the indirect method, but also more precise. In this construction method, the foundation and soil are modeled together in one step [1].

The finite element method is a numerical method for solving complex engineering problems. Unlike other numerical methods that are based on the mathematical discretization of the equations of boundary problems, the finite element method is based on the physical discretization of the considered area. Instead of elements of differentially small dimensions, the basis for the analysis is a part of the area of finite dimensions - the finite element. Therefore, the basic equations used to formulate the problem are simple algebraic. This means that the considered area, as a continuum with an infinite number of degrees of freedom, is replaced by a model of interconnected finite elements with a finite number of degrees of freedom. The basic task is to choose a model that will best approximate the boundary value problem. The accuracy of the calculation is defined by the quality of the selected mesh and the type of finite elements. The most commonly used finite elements in the analysis are 2D and 3D finite elements. Modeling the object using these elements, then defining the limitations and loads, as well as all the necessary mechanical properties of the material from which they are made, and finally solving the problem with numerical methods, leads to the desired results [10].

This paper presents an analysis of the interaction between the foundation slab and the soil using a model of a reinforced concrete building with Basement+GF+4 floors. The construction of the building is skeletal - it consists of reinforced concrete frames with a distance of 5 m in two orthogonal directions. The reinforced concrete elements have the same cross-section on all floors.



*Figure 2. Model off the structure*

The soil under the foundation slab is modeled as a half-space. This type of modeling involves representing the soil volumetrically, that is, using volumetric finite elements of appropriate characteristics. For the described object, for the sake of simplifying the calculation, a semi-space with a depth of 10 m was adopted, with dimensions 5 m wider on each side compared to the dimensions of the object, although the modeling of the ground as a semi-space theoretically means that the

semi-space is unlimited except on the upper side, where it is limited by the surface soil. With this type of modeling, the soil is described with two parameters: the type of soil is determined by the deformation modulus and Poisson's ratio. For the specific case, the soil whose Poisson's ratio is equal to 0.20 was adopted. The volumetric weight of the soil is adopted equal to  $20 \text{ kN/m}^3$ . The mesh of the finite elements of the subject-object is shown in Figure 3. The soil deformation modulus is variable for different cases of the soil model. The analysis shows the dependence of static influences on the thickness of the foundation slab and the size of the finite elements for different values of the soil deformation modulus. The following parameters were varied: the soil deformation modulus (10 MPa, 20 MPa, and 40 MPa), the thickness of the foundation slab (0.40 m, 0.50 m, and 0.70 m), and the size of the finite element (1.25 m, 1.5 m and 2 m).

The software package TOWER 8 was used for modeling, design, dimensioning of the structural elements and calculation of the effect of all structural reinforced concrete elements, applying the European standards - Eurocodes.

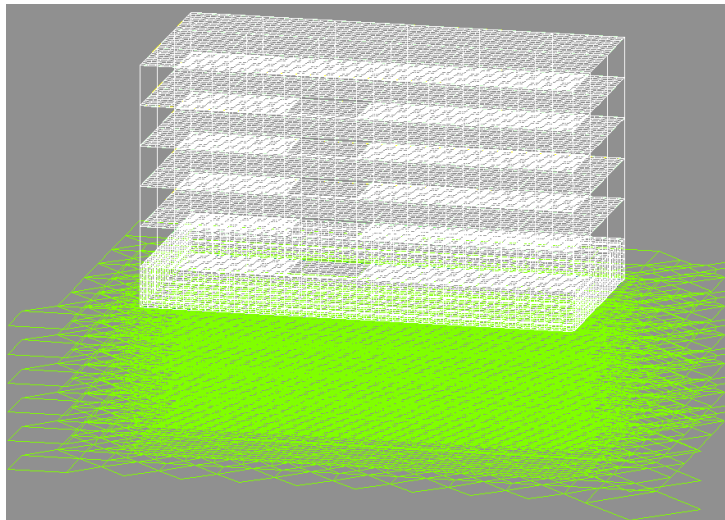


Figure 3. Finite elements mesh

During the analysis, the effects of seismic action and gravity (constant and variable) load were considered. Seismic impacts were determined by multimodal analysis with a design spectrum for the horizontal direction. EN 1998-1 prescribes the elastic response spectrum for horizontal seismic action with the following parameters: type 1 elastic response spectrum, soil category C ( $S=1.15$ ,  $T_b=0.2 \text{ s}$ ,  $T_c=0.6 \text{ s}$ , and  $T_d=2 \text{ s}$ ), maximum ground acceleration  $a_g=0.2g$ , correlation factor due to damping  $\eta=1$  and building significance factor  $\gamma=1$ ). For the analyzed construction, a high ductility class DCH was adopted, for which a total behavior factor of  $q=5.85$  was determined.

For the dimensioning of the supporting elements, concrete C30/37 and reinforcements B500B were used. The columns are reinforced with  $8\text{Ø}32$  and are weighted with stirrups  $\text{Ø}8/7,5 \text{ cm}$  on the length of the critical area and on the rest of the length  $\text{Ø}8/15 \text{ cm}$ . The beams in the supporting zones are reinforced in the upper zone with  $5\text{Ø}20$  and in the lower zone with  $3\text{Ø}20$ , and in the field in the lower zone with  $3\text{Ø}20$  and in the upper zone with  $2\text{Ø}20$ . Stirrups are placed at a distance of 10 cm. The foundation slab is modeled as unreinforced.

### 3. RESULTS

As reference parameters for the analysis, the following were derived from all the influences that occur in the structure: bending moments in the foundation slab ( $M_x$  and  $M_y$ ), stresses occurring in the foundation soil under the foundation slab ( $\sigma$ ), and soil settlement under the foundation ( $s$ ). Below, the results are presented graphically, and the exact values on the diagrams are tabulated.

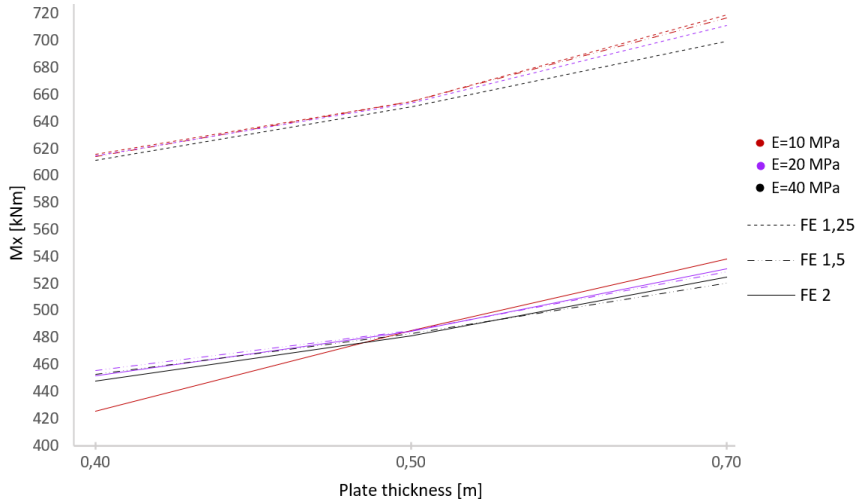


Figure 4. Bending moments  $M_x$  in the base plate

Table 1. Values of bending moments  $M_x$  in the base plate [kNm]

FE [m]	E=10 [MPa]			E=20 [MPa]			E=40 [MPa]		
	plate thickness [m]			plate thickness [m]			plate thickness [m]		
	0,40	0,50	0,70	0,40	0,50	0,70	0,40	0,50	0,70
1,25	615,9	655,2	719,3	615,1	654,3	711,5	611,9	651,2	700,0
1,5	614,5	655,0	717,9	455,8	485,7	529,0	453,4	483,3	520,7
2	425,5	485,7	538,3	451,8	484,7	531,5	448,2	481,8	525,3

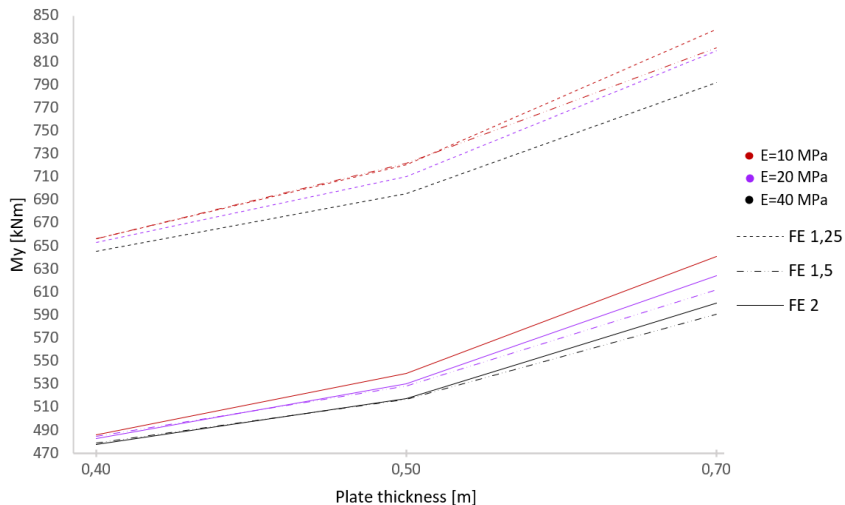


Figure 5. Bending moments  $M_y$  in the base plate

Table 2. Values of bending moments  $M_y$  in the base plate [kNm]

FE [m]	E=10 [MPa]			E=20 [MPa]			E=40 [MPa]		
	plate thickness [m]			plate thickness [m]			plate thickness [m]		
	0,40	0,50	0,70	0,40	0,50	0,70	0,40	0,50	0,70
1,25	656,7	720,5	838,4	653,1	710,6	819,7	645,6	695,9	792,4
1,5	656,4	721,8	822,6	484,6	528,3	611,9	487,8	517,1	590,8
2	486,2	539,4	641,2	482,9	530,6	624,6	478,5	517,8	600,3

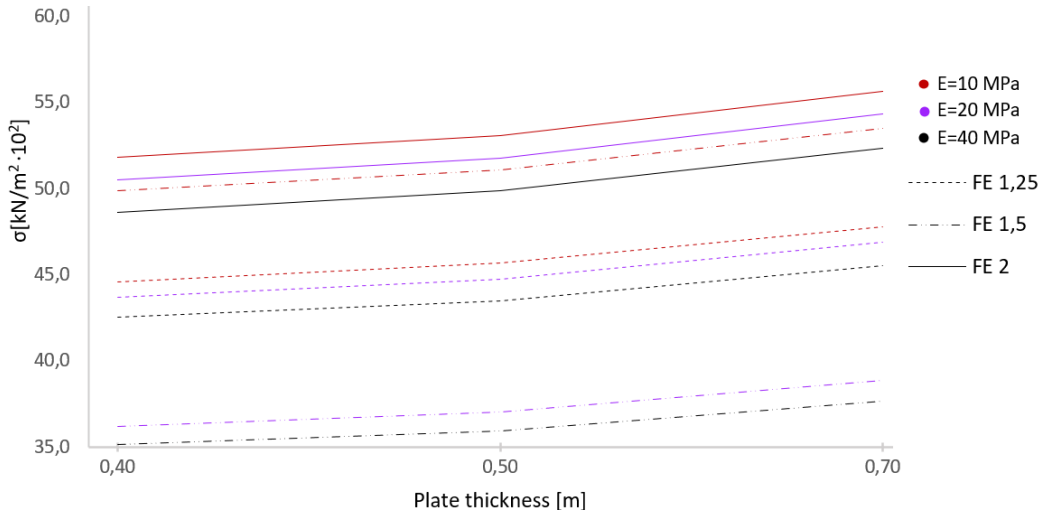


Figure 6. Stress in the underlying soil

Table 3. Values of stress in the underlying soil [kN/m<sup>2</sup> · 10<sup>2</sup>]

FE [m]	E=10 [MPa]			E=20 [MPa]			E=40 [MPa]		
	plate thickness [m]			plate thickness [m]			plate thickness [m]		
	0,40	0,50	0,70	0,40	0,50	0,70	0,40	0,50	0,70
1,25	44,63	45,69	47,82	43,74	44,78	46,93	42,58	43,50	45,56
1,5	49,90	51,10	53,54	36,20	37,07	38,87	35,18	35,95	37,67
2	51,84	53,12	55,65	50,51	51,78	54,36	48,74	49,88	52,37

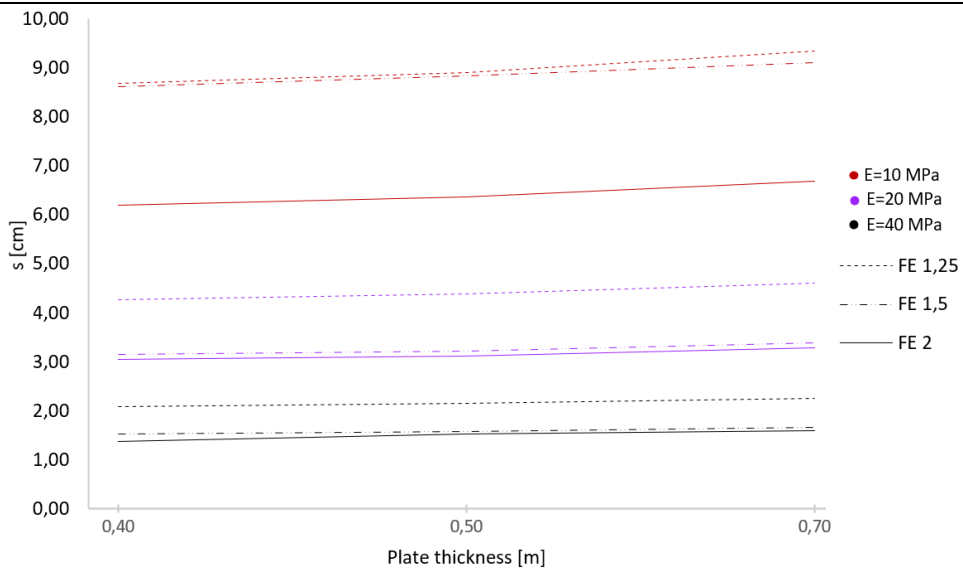


Figure 7. Ground settlement

Table 4. Values of ground settlement [cm]

FE [m]	E=10 [MPa]			E=20 [MPa]			E=40 [MPa]		
	plate thickness [m]			plate thickness [m]			plate thickness [m]		
	0,40	0,50	0,70	0,40	0,50	0,70	0,40	0,50	0,70
1,25	8,72	8,93	9,31	4,32	4,46	4,64	2,11	2,24	2,31
1,5	8,61	8,80	9,13	3,11	3,23	3,47	1,57	1,68	1,77
2	6,24	6,96	6,79	3,05	3,16	3,35	1,42	1,52	1,63

#### 4. DISCUSSION

By comparing the influence in the construction for different values of the soil deformation modulus E, shown in the diagrams in Chapter 3, the following can be concluded:

- Bending moments are proportionally smaller with increasing values of soil deformation modulus.
- If the dependence of the observed static influences on the thickness of the base plate is observed, the bending moments increase proportionally with the increase in the thickness of the base plate.
- From the aspect of analyzing the influence of the size of the finite elements, with which the soil is modeled, on the static effects, it can be noted that the size of the finite elements of 1.25 m and 1.5 m for the soil deformation module E=10 MPa give approximate values of the bending moments, and for the size of finite elements of 2 m and soil deformation modulus E=10 MPa, moment values are significantly lower. For the soil model with a mesh of finite elements of size 1.5 m and 2 m, for soil deformation modulus E=20 MPa and E=40 MPa, the bending moments

are approximately the same, while with finite elements of size 1.25 m, they are significantly higher.

- Observing the stresses in the foundation soil, it can be seen that the stresses in the soil increase with the increase in the thickness of the foundation slab and the size of the finite elements used to model the soil. With the increase of the deformation modulus of the soil, the stresses in the soil decrease.
- When it comes to soil settlements under the foundation, with the increase in the size of the finite element, the settlements decrease. The settlement curves on the presented diagrams for finite element sizes of 1.25 m and 1.5 m show that, for the soil deformation modulus of 10 MPa, the settlement values are approximately the same. For  $E=20$  MPa and  $E=40$  MPa and sizes of finite elements 1.5 m and 2 m, the settlement values are approximate.
- Settlements, when the soil is modeled with a soil deformation modulus of 10 MPa and finite elements of size 2 m, are significantly smaller than in the model where finite elements are of size 1.25 m and 1.5 m, while for  $E=20$  MPa and  $E=40$  MPa and mesh with the size of the finite elements of 1.25 m, the settlements are much larger compared to the model where the finite elements are 1.5 m and 2 m.
- With an increase in soil deformation modulus, settlements decrease proportionally.

## 5. CONCLUSION

The interaction of the foundation soil and the structure has a very important role in aseismic engineering. Globally, the objective strength of an earthquake is not important, but the consequences it leaves on objects are important. Given that the time of earthquake formation cannot be predicted, the only thing we can do is to mitigate the consequences of an earthquake by proper aseismic construction, and knowing the interaction of the underlying soil and the structure is one of the ways to mitigate the consequences [1].

Earthquake waves travel towards the surface of the ground for several tens of kilometers, which is impossible to model in calculations, but the depth of the ground is taken, which will include the effects of the earthquake and be comparable to the geometry of the structure. The interaction between the structure and the foundation soil is a combined system model that can physically and mathematically describe changes in the stiffness or flexibility of the foundation soil. Conventional theories talk about how the interaction effect is positive or beneficial to the structural response, while some analyses recommend ignoring the interaction terms, which can lead to poor structural design. It is true that interaction effects are insignificant in certain situations. but there are facilities and local soil conditions that do not allow calculations. Therefore, only a detailed knowledge of the interaction of the foundation soil and the structure is a guarantee of a successful and safe calculation [1].

If the time required for the calculation is excluded, it is recommended to model the construction with as many finite elements as possible, in which case the calculation is on the side of safety. Since rationality is one of the most important

factors during the design phase, it is possible to use finite elements of larger dimensions, where the rational explanation for this procedure would be the use of safety coefficients and the adoption of a slightly larger amount of reinforcement in the cross-section than the required amount in the dimensioning process. If the building is built on soil with given characteristics (Poisson's ratio is 0.20, bulk soil weight is 20 kN/m<sup>3</sup>, soil deformation modulus is 10 MPa), the proposal is to use a mesh of finite elements with the same size of 1.25 m, at in such a case, the influences in the construction are the greatest and therefore the designer is on the side of safety. The disadvantage of this model is that it is computationally the longest, due to the time required for the software to calculate all the necessary elements. Although it is computationally simpler, it is not recommended to model the soil with the size of finite elements of 2 m, due to the appearance of significantly smaller influences in the construction. If an object is designed on soil with a deformation modulus of 20 MPa or 40 MPa, it is recommended to model the soil with finite elements of size 1.25 m. In contrast to what was said previously (when E=10 MPa), here the sizes of finite elements of 1.5 m and 2 m give approximately the same values of the observed impacts, which are significantly smaller than the soil model with the size of finite elements of 1.25 m.

## REFERENCES

- [1] Zavrtnik Andrija: **Dinamička interakcija temeljno tlo-konstrukcija: geotehnički aspekti**. *Master's thesis, University of Zagreb, Faculty of Geotechnical Engineering, Zagreb, 2021.*
- [2] Čosić Mladen: **Analiza interakcije konstrukcija-tlo nelinearnom statičkom seizmičkom analizom**. *Geotehnički aspekti građevinarstva, III naučno savetovanje, Zlatibor, 2009.*
- [3] Ravi Shankae Badry: **Numerical Modelling of Soil-Structure Interaction using Efficient Radiating Boundary Conditions**, *International Institute of Information Technology Hyderabad, Hyderabad - 500 032, India, 2023.*
- [4] Edger Lewis, Sanayei Masoud: **Modeling the effects of soil-structure interaction on a tall building bearing on a mat foundation**, *Civil Engineering Practice, Vol. 20, No. 2, 51-68, 2005*
- [5] Stevanović Stevan: **Fundiranje I**, *Naučna knjiga, Beograd, 1989.*
- [6] [https://www.grad.unizg.hr/download/repository/G4\\_Plitki\\_temelji.pdf](https://www.grad.unizg.hr/download/repository/G4_Plitki_temelji.pdf) (1.6.2023.)
- [7] Requena-Garcia-Cruz Maria Victoria, Bento Rita, Percy Durand-Neyra, Morales-Esteban Antonio: **Analysis of the soil structure-interaction effects on the seismic vulnerability of mid-rise RC buildings in Lisbon**, *Structures, Vol. 38, No. 1, 599-617, 2022.*
- [8] Santrač Petar: **Fundiranje-interakcija konstrukcije i tla**, *Univezitet u Novom Sadu, Građevinski fakultet Subotica, Subotica, 2021.*
- [9] Mirković Vladimir, Užar Josip: **Primjena metode konačnih elemenata u građevinarstvu**, *Technical journal, Vol. 6, No. 2, 202-206, 2012.*
- [10] <https://pdfcoffee.com/qdownload/--2031-pdf-free.html> (23.5.2023.)



# EXPLORING THE POSSIBILITY OF CONNECTING THE GAME ENGINE AND GIS AS MEANS OF DECISION SUPPORT IN URBAN PLANNING

Petar Vranić<sup>1</sup>, Dušan Tatić<sup>2</sup>

## Abstract

*Geographic Information Systems (GIS) systems are computer programs that can precisely define, mark and analyze geospatial data. On the other hand, game engines are software tools that can be used to visualize and interact with this geospatial data in virtual worlds such as virtual reality or combined with real-world like in augmented reality. Therefore, game engines and GIS can be combined to develop effective and interactive applications. This interconnection of software tools can be implemented to assist in simulation for policymakers and stakeholders in urban and environmental planning to make better decisions or better design their study. Also, by combining these software tools urban planning and environmental simulation can offer a better understanding of complex interactions between the built environment and environmental phenomena, like weather patterns, water flows, waste disposal, etc. In this paper, we explore the possibilities of a combination of Unity and QGIS by realizing communication that allows the exchange of a variety of geographic data structures. This process of communication is achieved by exchanging data using GeoJSON format with the purpose of definition, presentation, and analysis of the geospatial data. We used it in the case of urban green infrastructure (UGI) and its environmental services as scenario of its deployment in supporting decision-making process in urban planning. Realizing such communication of these software tools for UGI can aid both decision support processes in UGI development but also can be utilized to raise awareness and educate people about its various benefits.*

**Key words:** *Urban Planning, Game Engine, Decision Making, GIS, Green Infrastructure*

---

<sup>1</sup> PhD, Research Associate, Mathematical Institute SANU, petarvvv@mi.sanu.ac.rs

<sup>2</sup> PhD, Research Associate, Mathematical Institute SANU, dusan.tatic@mi.sanu.ac.rs

## 1. INTRODUCTION

There are ever-increasing plethora of available technologies like integration of smart city technologies such as IoT (Internet of Things) sensors, smart grids, intelligent transportation systems, application of GIS, various types of urban simulation and modeling, real-time transit information, online platforms, mobile apps and virtual town halls for public engagement and participation, or data analytics and predictive planning, etc. In this paper, we will discuss the potential of combining GIS and Game engine as a decision-support technologies in urban planning process. Before that, in the following lines, we will introduce their roles in this field and some examples of their hybrid applications.

GIS is becoming increasingly important in urban planning and design practice. By integrating data from multiple sources, and applying certain analytical rules, GIS provides a basis for comparison and assessment, as well as systematization of results in the decision-making process in urban planning [1]. However, for a long time, it has been employed by planners to a large extent exclusively for visualizing spatial data, despite its capacity to serve as a planning support system [2]. The application of GIS can effectively support strategic decision-making in urban planning by various means through resource inventory, land-use maps and plans, impact assessments, evaluation, etc. It enables spatial analysis by allowing users to superimpose diverse datasets and data types, and assess spatial correlations between distinct elements, which allows the identification of patterns, hotspots, and trends in areas like population density, land use patterns, or transportation networks [3]. By combining data like zoning restrictions, property values, environmental elements, it assists in land use planning enabling the assessment and optimization of land use patterns for efficient urban growth and development [4]. It plays a critical role in transportation planning in the analysis of transportation networks, traffic patterns, and accessibility. Urban planners may in addition use GIS to examine environmental concerns in urban settings by mapping and analysis of urban green infrastructure, natural regions, watersheds, and natural resources and make informed choices to control urban expansion and reduce environmental consequences by overlaying environmental data with other urban data. GIS can help in locating suitable sites for infrastructure facilities, assessing service coverage, and analyzing the urban effect of infrastructure developments.

Similar to GIS, game engines are rapidly being used in urban planning and design, providing useful tools for simulating, visualizing, and analyzing urban landscapes [5]. Designers may use game engines (GE) to realistically simulate projects and examine them from many angles, allowing stakeholders to have a greater understanding of the project's overall impact. Immersive experiences are also supported by game engines via virtual reality (VR) or augmented reality (AR), allowing users to "walk through" and interact with the newly designed urban areas [6, 7]. GE allows scenario testing by illustrating numerous urban planning instances and their potential implications. Planners can model traffic patterns, pedestrian movement, sunshine and shadow analyses, noise propagation, and other aspects to assess the feasibility and efficacy of various design options [8]. This supports informed recommendations, improving urban plans, and forecasting the effects of planning decisions. Game engines provide a collaborative environment for stakeholders to participate in the urban planning process. Planners may engage people, community groups, and decision-makers in conversations and obtain input

on suggested designs by providing virtual settings [9]. This participatory method encourages openness, cooperation, and diversity, ensuring that different points of view are considered in decision-making. This method aids in the refinement of urban designs, the early identification of possible concerns, and the promotion of collaborative problem-solving. Game engines may be used to instruct urban planners and designers as educational tools [10]. They provide a hands-on learning environment in which students may experiment with urban planning principles, examine the impact of various interventions, and receive hands-on experience in developing and managing urban places.

Regardless of their potential, Game engines and GIS have been marginally exploited when it comes to their hybrid application in the domain of urban planning and related fields. Some examples include the integration of GIS and AR in landscape visualization where the author modeled realistic panoramic video frames to dynamically augment a landscape view with modeled temporal changes. The communication is written in VisualBasic and uses commercial GIS software [11]. Reference [12] reports on an experiment in the construction of the Unity engine based on the WebGIS system for the hydrological and water hazard information display. A hybrid approach was also applied in heritage preservation. In the work of [13] authors combined 3D-GIS District Models and BIM-Based Building Models into Computer Gaming Environment to enhance conservation workflow. They applied ArcGIS and SketchUp as the information modeling software and used the Unitygame engine as the development platform, and carries out the integration and interactive presentation of the scene information model through the two-stage process of information modeling and programming integration. Furthermore Chen et al., developed a prototype system implementing an in-field collaborative visualization environment to facilitate decision support in landscape planning and environmental management based on live linking ArcGIS with a fully immersive collaborative virtual decision environment that uses the commercial low-cost Torque Game Engine [14].

In line with above mentioned, the main goal of this paper is to explore the possibilities of linking game engines and GIS by realizing communication that allows the exchange of a variety of geographic data structures. To exemplify the basic characteristics of established communication, we used UGI as a domain of urban planning that gained much attention in recent years. UGI has been widely promoted in recent years as a more sustainable and cost-effective alternative for climate change adaptation and microclimate amelioration than physical infrastructure, particularly at the municipal level [15]. UGI provides significant ecosystem services (ES) [16], which include environmental, socio-cultural, public health, and economic benefits [17]. There is an increasing interest in both the measurement of ES and in placing an economic value on the multiple benefits associated with UGI [18]. Thus, the development and improvement of instruments and tools for inventory and assessment of UGI to inform planning and decision-making in this domain become increasingly important. Thus as a secondary objective this paper is an effort to make a contribution to this field.

In the following section we describe main features of the used software.

## 2. USED SOFTWARE TOOLS

For developing the communication, we employ two software tools QGIS and Unity.

QGIS (Quantum GIS) is a free and open-source GIS program for viewing, analyzing, and managing geographical data. Vector (points, lines, polygons), raster (imagery, elevation data), and tabular (attribute tables) data formats are supported by QGIS. Data may be loaded from a number of sources, like databases, GPS devices, web services, and other GIS tools. QGIS also supports data administration and organization, as well as the creation and updating of geographical datasets. QGIS has a comprehensive set of geoprocessing and spatial analysis capabilities. It supports geographic querying, buffer creation, spatial joining, overlay analysis, interpolation, terrain analysis, and other functions. It offers a plugin design that allows users to extend the functionality of the software. Users may utilize Python programming to construct their own plugins, allowing for customization and automation of certain procedures. Further, QGIS supports interoperability with other GIS applications and data formats. It supports widely used industry standards like Shapefile, GeoJSON, KML, WMS, and WFS. QGIS also interacts with a variety of geographic databases, including PostgreSQL/PostGIS, allowing for smooth data interchange between software systems [19].

Unity is a game engine that enables the development of cross-platform applications for different device types (like mobile devices, desktop computers, game consoles, VR/AR devices, and others) and supports various operating systems (like Android, iOS, Windows, and others). Therefore, developing one application may be distributed on various platforms with only minor or no modifications. The programming language used is C# which allows the development of the application logic, user interface interactions, and connectivity with the various types of services. Also, Unity supports both 2D and 3D graphics rendering and has a built-in physics engine that enables manipulating 2D and 3D objects, physics simulations, collisions, gravity, and others. This game engine has a strong community that develops various libraries, plugins, and assets for faster and better creation of project realizations. Except for game development, as a powerful multimedia tool, Unity is used for various non-gaming applications concerning various types of research projects for healthcare, cultural heritage, or industry.

The remainder of the paper is organized as follows. Firstly, in the communication section, we describe the communication between the presented software's. Secondly, we exemplify how the established connection can be utilized to inform decision-making processes in the planning of UGI. And thirdly, in the concluding part, we briefly reflect on the potential limitations and further development of the concept.

## 3. COMUNICATION

Utilizing the capabilities of the above-mentioned software, we created a baseline communication link in order to realize the Decision Support System for Urban Green Infrastructure Planning (DSfUGP). The DSfUGP structure contains on the client side mobile application and data analytics as shown in Figure 1.

Unity is used for creating mobile application that is a part of the DSfUGP system responsible for field surveys i.e., geo-located data management. The system offers

two possibilities: 1) entering the requested parameters of the object of interest collected by the inspection officer at the exact place of the survey, and 2) visualizing previously stored data by the inspection officers or data processed by experts doing analytics with QGIS software. In this way, the system allows direct communication between the field inspection officers and data analysts.

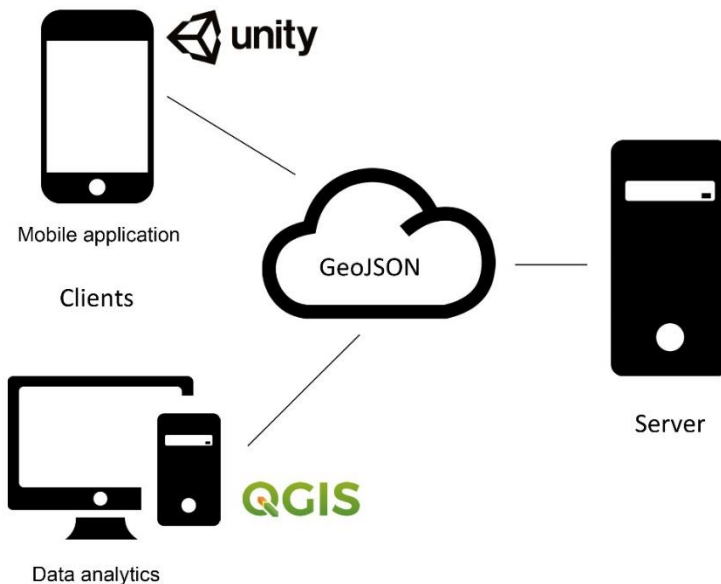


Figure 1. DSfUGP client and server communication

QGIS is part of DSfUGP system and serves as a desktop application used for data processing and data analytics. When information is sent from the field via a mobile application, QGIS receives the data. The use of specialized toolboxes for processing these data results in the generation of new parameters that are prepared to send back to the client's mobile application. Access to already processed data can rise contextual understanding of the object of interest which can further enhance the inspection experience.

Exchanging data between both system tools QGIS and mobile application created in Unity is achieved through GeoJSON file format. This file format is based on JavaScript Object Notation (JSON) and is made to store structured object data. JSON object data are in the form of name-value pairs and serializable structures like arrays. This format is encoded as a human-readable text independent of the programming language. Also, each programming language can generate code that can read and create JSON file format. Therefore, this file format best serves (as a client-server format) to transmit or exchange data between applications. Accordingly, the GeoJSON file format is an open standard that serves to store and exchange geographical features and attributes.

GeoJSON file is stored on the remote server from which mobile and desktop applications can access data. Mobile applications have purposely designed generated code and object structures to manipulate this file format. To receive this data from the server web request is created. After receiving the data from the server

deserialization of this data is done and further process enabled. Each geometry is presented as an interactive pin on the map. When interaction with the pin is achieved features can be shown. Seemingly, when the interaction is achieved, outside of the pin on blank position on the map, the form is shown for adding a new pin. Entering the requested data, a new element is generated in GeoJSON format. Data are sent to the remote server to update the GeoJSON file. To send this data, a web request is generated, and the code is sent to a service that parses and updates the GeoJSON file. The desktop application receives GeoJSON files via a connection link stored in Data Source Manager. Data received from the server can be visualized in the QGIS environment and may be used for further analysis.

#### 4. CASE STUDY

The described system is illustrated in the cases of trees in the schoolyard of an elementary school in Niš. The data about trees are provided during the science manifestation “May the Month of Mathematics” held in May 2023, where biology teacher were supervising pupils in evaluating tree’s conditions. We used one sample to simulate communication between the inspection officer and data analyst. The data structure created aimed to support field inspection of tree conditions to understand the value of their ES in terms of carbon sequestration, air pollution removal, flood prevention, and its influences on the energy efficiency of nearby buildings. Data structure included the following qualitative and quantitative properties: name of the school, number of trees, circumference, tree condition, dominant tree species, sun exposure, building age, distance from the building, and orientation/direction from the building. We selected listed variables following iTree tool as the basic parameters for calculating exemplified ES. When a new pin is added, the user is requested to fill out the form on his mobile device using this data. GeoJSON described in Figure 2 is used in the DSfUGP system.



Figure 2. GeoJSON code and mobile application user interface

The data embedded by the “inspection officer” using the mobile application are uploaded to the server from which data are directly downloaded to QGIS environment for further analysis. Using the third-party app - iTree tool, collected data are analyzed in GIS environment and ES services received monetary values in US dollars. The results of analytics are then stored as attributes of QGIS in the point vector layer. The newly created data are exported to the GeoJSON file and sent to the server (Figure 3).

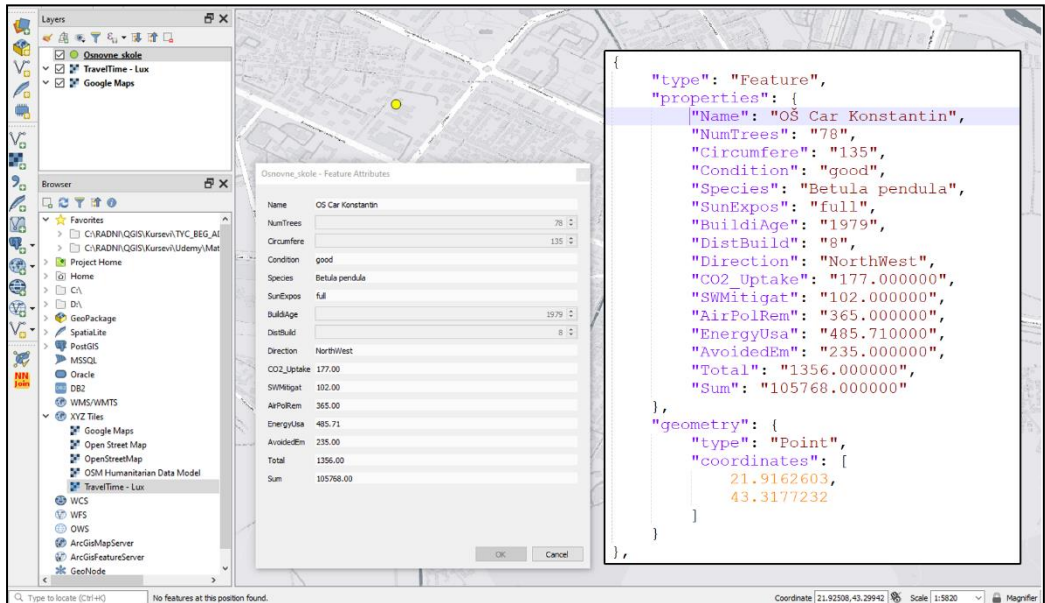


Figure 3. GeoJSON code with processed data

After the file is updated on the server use of the mobile app is able to read processed data for the particular point (Figure 4). In this exercise, we worked with suitable point vector layers for single tree inventory. With the adjustment of code, it is possible to transfer linear and polygonal vector data between the software. This will obviously enable various other UGI inventory scenarios and study exercises.



Figure 4. A display of the processed data in mobile application

## 5. CONCLUDING REMARKS

In this paper, we described the baseline communication link between Unity and QGIS that allows for geo-located data management. The solution presented allows field inspection officers and data analysts to communicate directly. The Unity game engine is used to develop mobile applications that exchange data with QGIS via GeoJSON file format. The use case for DSfUGP system is to facilitate field inspection of UGI encompassing data like carbon sequestration, air pollution removal, flood prevention, and its influences on the energy efficiency of adjacent buildings. In this case, we showed the code for the point layer that can be applied for single tree inventory. However, adjustment of the code link will allow communication of linear and polygonal structures. This will further enable an inventory of diverse types of UGI like parks, rain gardens, storm water canals, green roofs, and various grasslands and provide a valuable contribution as UGI planning tool that can assist decision-makers.

Since GIS is a type of structured database representing a spatially oriented information system, it can expand its capability to PostGIS environment for comprehensive data-management operations in MSSQL or PostgreSQL. In this way, combining game engine versatile visual communication capabilities, besides the inspection of UGI, DSfUGP can support more sophisticated workflow between various actors in various domains of urban planning.

As we explained previously, the introduced communication of mentioned software tools presents a baseline DSfUGP system which currently works for a given use case. Bearing that in mind, the limitation of the presented exploration is in a lack of different types of vector layers, and simultaneous edits of multiple users. Further research considers two main directions. The first comprises automation of the communication process and implementation of more sophisticated spatial analysis.



The second is related to client experience, i.e., exploring possibilities of expanding DSfUGP by means of VR and AR experience that can enrich visual communication of data and hence improve cognition of ES and the importance of UGI.

## ACKNOWLEDGMENTS

This work was supported by the Serbian Ministry of Science, Technological Development and Innovation through the Mathematical Institute of the Serbian Academy of Sciences and Arts.

## REFERENCES

- [1] Mat, A., and Jack, D.: **A GIS-based Framework for Modelling and Global Design of Earth Systems**. T. P. Singh & P. K. Joshi (Eds.), *Geoinformatics for Climate Change Studies*. teri - The Energy and Resources Institute, New Delhi, 2011.
- [2] Morales Jose, Johannes Flacke, and Javier Martinez: **A Collaborative Planning Framework to Support Sustainable Development: The Case of Municipal Housing in Guatemala City**. *GIS in Sustainable Urban Planning and Management*, 29-44, CRC Press, 2018.
- [3] Singh Yamini Jain, Johannes Flacke, Mark Zuidgeest, and Martin van Maarseveen: **Planning for Transit Oriented Development (TOD) using a TOD index**. *GIS in sustainable urban planning and management*, 267-282, CRC Press, 2018.
- [4] Pérez-Molina Eduardo, Richard Sliuzas, and Johannes Flacke: **Simulating spatial patterns of urban growth in Kampala, Uganda, and its impact on flood risk**. *GIS in Sustainable Urban Planning and Management*, 295-306, CRC Press, 2018.
- [5] Perhac Jan, Wei Zeng, Shiho Asada, Stefan Mueller Arisona, Simon Schubiger, Remo Burkhard, and Bernhard Klein: **Urban fusion: visualizing urban data fused with social feeds via a game engine**. *21st international conference information visualisation (IV)*, IEEE , 312-317, 2017.
- [6] Davis Calvin, Jaired Collins, Joshua Fraser, Haoxiang Zhang, Shizeng Yao, Emily Lattanzio, Bimal Balakrishnan, Ye Duan, Prasad Calyam, and Kannappan Palaniappan: **CAVE-VR and Unity Game Engine for Visualizing City Scale 3D Meshes**. *2022 IEEE 19th Annual Consumer Communications & Networking Conference (CCNC)*, IEEE, 733-734, 2022.
- [7] Potts, Ruth, Lisa Jacka, and Lachlan Hartley Yee: **Can we 'Catch 'em All'? An exploration of the nexus between augmented reality games, urban planning and urban design**. *Journal of Urban Design* Vol. 22, No. 6, 866-880, 2017.
- [8] Kazhamiakina, Raman, Annapaola Marconi, Mirko Perillo, Marco Pistore, Giuseppe Valetto, Luca Piras, Francesco Avesani, and Nicola Perri: **Using gamification to incentivize sustainable urban mobility**. *IEEE first international smart cities conference (ISC2)*, IEEE, 1-6, 2015.
- [9] Kent Lee, Chris Snider, and Ben Hicks: **Engaging citizens with urban planning using city blocks, a mixed reality design and visualisation platform**. *Augmented Reality, Virtual Reality, and Computer Graphics: 6th International Conference, AVR 2019, Santa Maria al Bagno, Italy, June 24–27, 2019, Proceedings, Part II* 6, Springer International Publishing, 51-62, 2019.
- [10] Calvo Xavier, David Fonseca, Mónica Sánchez-Sepúlveda, Daniel Amo, Josep Llorca, and Ernesto Redondo: **Programming virtual interactions for gamified**

- educational proposes of urban spaces.** *Learning and Collaboration Technologies. Learning and Teaching: 5th International Conference, LCT 2018, Held as Part of HCI International 2018*, Las Vegas, NV, USA, July 15-20, Proceedings, Part II 5, Springer International Publishing, 128-140, 2018.
- [11] Ghadirian, Payam, and Ian D. Bishop: **Integration of augmented reality and GIS: A new approach to realistic landscape visualisation.** *Landscape and Urban Planning* Vol. 86, No. 3-4 (2008): 226-232.
- [12] Gang, Su-Myung, Hyeoung-Wook Choi, Do-Ryeong Kim, and Yun-Jae Choung: **A study on the construction of the unity 3D engine based on the webGIS system for the hydrological and water hazard information display.** *Procedia engineering* Vol. 154 (2016): 138-145.
- [13] Ma, Yu-Pin: **Extending 3D-GIS district models and BIM-based building models into computer gaming environment for better workflow of cultural heritage conservation.** *Applied Sciences* Vol. 11, No. 5 (2021): 2101.
- [14] Tao Chen, Christian Stock, Ian D. Bishop, Alice N. O'Connor: **Prototyping an in-field collaborative environment for landscape decision support by linking GIS with a game engine.** *Proc. SPIE 6418, Geoinformatics 2006: GNSS and Integrated Geospatial Applications*, 641806 (28 October 2006).
- [15] Maes Joachim, Anne Teller, Markus Erhard, Patrick Murphy, Maria Luisa Paracchini, José I. Barredo, Bruna Grizzetti et al.: **Mapping and Assessment of Ecosystems and their Services: Indicators for ecosystem assessments under Action 5 of the EU Biodiversity Strategy to 2020 – Technical Report - 2014-080**, European Commission, 2014.
- [16] Costanza, Robert, Rudolf de Groot, Stephen Farber, Monica Grasso, Bruce Hannon, Karin Limburg, Shahid Naeem et al.: **The value of the world# s ecosystem services and natural capital.** *Ecological economics* Vol. 25, No. 1 3-15, 1998.
- [17] **Millennium ecosystem assessment, M. E. A. Ecosystems and human well-being. Vol. 5.** Island press, Washington, DC, 2005.
- [18] Rogers Kenton, Maria-Beatrice Andreucci, Nerys Jones, Anže Japelj, and Petar Vranic: **The value of valuing: recognising the benefits of the urban Forest.** *The urban forest: Cultivating green infrastructure for people and the environment*, Springer, 283-299, 2017.
- [19] Kurt Menke: **Discover QGIS 3. x: a workbook for the classroom or independent study.** Locate Press (2019).

## LARGE HOUSING ESTATES IN POST-SOCIALIST PERIOD: DEVELOPMENT STRATEGIES AND PRACTICE

Jelena Đekić<sup>1</sup>, Milena Dinić Branković<sup>2</sup>, Milica Ljubenović<sup>3</sup>, Milica Igić<sup>4</sup>, Mihailo Mitković<sup>5</sup>

### Abstract

*Large housing estates represent one of the most significant spatial legacies of socialism, but also one of the key challenges of urban development in post-socialist cities. After the fall of socialist regimes throughout the region, dramatic changes affected all spheres of society, including changes in the housing sector, characterized by complete withdrawal of state from housing and collapse of the East European housing model. Under such circumstances, the fate of large housing estates depended on the transition path of post-socialist cities. Housing privatization and restitution, which took place at different pace in Central and East European (CEE) countries, significantly influenced the development of large housing estates.*

*The paper discusses development strategies for large housing estates in CEE countries in post-socialist period, as well as the situation in Serbia. The socialist housing legacy in Serbia was mostly left to spontaneous development, i.e. individual strategies, supported by urban planning and legislation.*

*The paper presents two case studies of LHEs in Serbia that experienced different development in post-socialist period. Krive Livade neighborhood in Niš is analyzed as a typical LHE which has undergone dramatic changes in physical and functional structure in post-socialist period and is still going through changes. On the other hand, Cerak Vinogradi LHE in Belgrade was declared a spatial cultural and historical entity due to its characteristics that, despite the changes, remained well preserved over time. This represents one of the first examples of state protection of socialist heritage in Serbia.*

**Key words:** large housing estates, post socialism, Serbia

---

<sup>1</sup> PhD, Assistant Professor, Faculty of Civil Engineering and Architecture, jelena.djuric@gaf.ni.ac.rs

<sup>2</sup> PhD, Associate Professor, Faculty of Civil Engineering and Architecture, milena.dinic@gaf.ni.ac.rs

<sup>3</sup> PhD, Assistant Professor, Faculty of Civil Engineering and Architecture, milica.ljubenovic@gaf.ni.ac.rs

<sup>4</sup> MArch, Assistant, Faculty of Civil Engineering and Architecture, milica.igic@gaf.ni.ac.rs

<sup>5</sup> MArch, Assistant, Faculty of Civil Engineering and Architecture, mihailo.mitkovic@gaf.ni.ac.rs

## 1. INTRODUCTION

Population growth and accelerated urbanization after World War II created an increased need for housing in cities across Europe. In given circumstances, construction of high-density mass housing was efficient mean of satisfying the housing needs. Despite significant differences in public policies and institutions, housing models in socialist countries, shared numerous similarities making the so-called "East European housing model" [1]. Main characteristics of this model are: 1) state domination in housing construction and distribution and 2) housing as a social right, not as a commodity. Responding to growing need for housing in cities, socialist authorities prioritized the construction of high-density residential areas on the outskirts of the city, where large areas of available state-owned land were suitable for mass prefabricated construction. The construction of large housing estates (LHEs) began in the 1950s, but the largest part was built in the 60s, 70s and 80s [2]. They represented 40-50% of the total housing stock in former socialist cities and housed more than half of the city's population [3]. This type of housing was considered "housing for the masses", it was planned centrally, while local authorities were in charge for implementation, i.e. selection of appropriate locations to accommodate the planned number of housing units [4]. The spatial scale of LHEs and the number of built apartments made them a recognizable characteristic of socialist cities and a key factor in housing provision during socialist period.

The fall of socialist regimes and dramatic political changes in the 1990s marked the beginning of multifaceted economic, social and cultural transformations of former socialist cities. Despite specific development conditions, caused by disintegration of the state and civil war, Serbian cities experienced similar transformations to those in other post-socialist cities in the region. The post-socialist transition in housing sector can be shortly described as disintegration of the Eastern European housing model. By moving away from this housing model, market mechanisms gain a more significant role in the housing sphere, while state responsibility, power, and resources weaken. As stated by Stanilov (2007) the main principles of housing reform in post-socialism are: privatization, deregulation, and reduction, i.e. cessation of state funding [5]. Large housing estates, as one of the most striking spatial legacies of socialism, experienced dramatic changes in post-socialist era.

The aim of the research is to understand the context of the LHEs development and their characteristics, as well as their transformation in the post-socialist period in Serbia. The research identifies public strategies for LHEs development and their application in Serbia, through the analysis of two LHEs: 1) Krive Livade neighborhood in Niš, a part of larger Bulevar Nemanjića LHE, which underwent significant transformations in the post-socialist period, and 2) Cerak Vinogradi LHE in Belgrade - the first example of legal protection of LHE in Serbia. Case studies included the analysis of current state of LHE, applied public and/or private development strategies, as well as planning documents and legal framework that made basis for spatial and functional transformations.

## 2. SPATIAL AND FUNCTION CHARACTERISTICS OF LHE

Development of LHEs began after the Second World War in CEE countries, and it was shaped by different factors including socialist political system and ideology

(central planning, state ownership of land and means of production, etc.), modernist principles in urban planning, use of neighborhood (microrayon) as a basic unit of urban planning and industrialization i.e. use of prefabricated construction.

Common characteristic of socialist projects was their large spatial scale which was grounded in socialist economic mechanisms, but it was also ideologically loaded [6] - spatial grandeur was the proof of the victory of the public over the private [6,7]. Construction land was mostly state (or socially) owned, which enabled the implementation of large state projects without taking into account land prices and property rights. Although the scale of housing projects was primarily the result of the functionalist approach to the housing shortage and based on the principles of economies of scale (cheaper and more efficient production of a large number of standardized housing units), the "big is beautiful" attitude among the politicians, government officials and state enterprise managers [8] also affected their size. Some authors state that LHEs were much larger than similar estates in Western countries and actually had no counterpart in capitalist cities [9].

LHEs were usually located on the city outskirts, connected to the city center by wide boulevards. Traffic flows were separated, with car traffic on the perimeter of neighborhood and pedestrian paths and leisure spaces in the inner area, undisturbed by traffic. Primarily planned as self-sufficient neighborhood units, with a wide range of amenities and services within walking distance, in practice they mostly remained monofunctional residential areas. In socialist cities, housing was set as a priority, and once the planned number of residential units was reached and most urgent goal achieved, the construction of other amenities was postponed [10].

Standardization and prefabricated construction enabled rapid replication, which affected the function and appearance of individual buildings and entire LHEs. Some authors state that LHEs projects focused on the architecture of the complex, as a reflection of subordination of parts to the whole, instead of architecture of buildings that emphasizes individuality [11]. They explain that a single building didn't represent a decorative element, but an element of the physical composition, whereby the layout of building assemblies created diversity and sense of spaciousness while maintaining a human scale.

Modernist principles in urban planning, one of the main shaping factors are reflected in oversized green areas, positioning of buildings to provide sufficient sunlight to apartments and in pedestrian connectivity of the neighborhood [11, 12]. Residential neighborhoods with freestanding buildings and large green areas supposed to ensure optimal microclimatic and sanitary conditions, as well as leisure and recreation areas in immediate vicinity of the apartment. It is often stated that the modernist concept of "tower in the park" found its purest expression in soviet microrayons [13].

Differences between countries, and even between individual cities at the national level, led to different quality of built LHEs. However, some common LHE characteristics such as: large proportion of public open areas and greenery; spaciousness and sufficient distance between buildings; good traffic connection with the city center; separation of traffic flows on neighborhood level; etc. are considered as their main qualities. On the other hand, the most criticized characteristics of LHE are: low quality construction; monofunctionality; lack of public services and commercial facilities; visual uniformity; lack of architecture as a result of prefabricated construction; underutilization and poor maintenance of open spaces,

etc. These problems became even more visible in post-socialist conditions and led to significant transformations of LHE. Although the majority of multi-apartment buildings built in the 1960s, 1970s and 1980s in Serbia is at much higher quality than in other post-socialist countries [13], similar problems can be recognized in LHEs in Serbian cities.

### 3. LHE POST-SOCIALIST DEVELOPMENT STRATEGIES

The end of state socialism in 1990s marked the beginning of reforms leading to market economies and democratic governance; hence, the term "transition" is commonly used for the post-socialist period [15]. The transformation towards a capitalism shows certain common characteristics in all former socialist countries, the so-called "general transition path", but also some peculiarities conditioned by different initial positions, political, economic and social factors. As a result, there are numerous sub models within the general model of the post-socialist city - for example, Tosics (2005) distinguishes eight sub-types of development in post-socialist cities [16]. Most of the countries of the region recorded an increase in unemployment, an explosion of the inflation rate, collapse of state-guaranteed services, a drastic drop in living standards and a sharp increase in social stratification.

Being an integral part of urban structure, LHEs had also experienced significant transformations, dependent on country's development path, shaped by different political, economic and social processes [17]. Privatization of the formerly state and municipal housing stock was the core transformation process in housing estates [18, 19], which created a society of homeowners and affected further spatial and functional changes. In general, three LHEs post-socialist development modes, followed by different transformation types, can be recognized: 1) total neglect and decay of buildings and/or public open spaces; 2) uncontrolled and uncoordinated development and renovation and 3) fully renovated housing stock [20].

Regarding public strategies, there are three major pathways [20, 21, 22]: 1) "doing nothing" - not intervene and leave potential changes to markets with little public involvement; 2) wholesale demolition of apartment buildings and housing estates; 3) integrated approach - based on policies and planned interventions aimed at upgrading housing estates both physically and socially.

The first strategy was present in many post socialist countries mid-1990s, in the initial phase of transition, after which they consolidated their housing and urban policies [20].

Wholesale demolition of existing housing stock was implemented in former East Germany cities and Moscow [20]. In 2017 Moscow announced demolition of 7,900 "*khrushchevka*" apartment buildings from 1950s and 1960s and their replacement with new modern apartment towers [23]. The third, "integrated strategy", which falls between the first two "extreme" strategies, is directed towards renewal and regeneration through different types of policy interventions: place-based, connectivity-based and people-based [20].

Having in mind that transition in Serbia took place under specific political and socio-economic circumstances, with a delay of a decade compared to other countries in the region, it can be said that Serbia is still going through the transition process, i.e. is in the phase of "mature transition" [24]. As stated by Vujošević (2012),

in first two decades of transition, there has been retrogression in terms of strategic thinking, research, governance and overall "planning culture" [25]. Regarding the LHE development strategies, "doing nothing" strategy was and still is the most common in Serbian cities. LHEs are facing a significant changes caused by uncontrolled, uncoordinated, fragmentary and often illegal actions, rather than clearly defined urban renewal strategy and projects [20].

As a result of uncontrolled and uncoordinated LHEs development in Serbia, the following transformations are observed [20, 26, 27]: 1) new residential development between the existing buildings ("infill"), 2) new infill commercial development; 3) multi-storey housing extensions in the form of additional floors or attics on "hosts" buildings; 4) quantitative and qualitative reduction of public open spaces; and 5) the emergence and expansion of services and small-scale retail through the transformation and adaptation of the ground floors spaces of residential buildings, so called "garage capitalism".

Different development paths of LHE in the post-socialist period are shown through examples: 1) Krive livade neighborhood (a part of Bulevar Nemanjića LHE) - an example of uncontrolled post-socialist development supported by legislative and planning documents and 2) Cerak Vinogradi LHE protected as a spatial cultural-historical unit.

## 4. CASE STUDIES

### 4.1. Krive livade, Niš

Krive Livade neighborhood is a part of Boulevard Nemanjića LHE, developed on the edge of the city in the mid-1970s as a typical socialist mono-functional housing area. The first urban plan for this area was adopted in 1969 and the construction started the same year, but the LHE was only partly built according to that plan. In later years, this plan was abandoned and new detailed zoning plans were drawn up for individual neighborhoods. For example, Krive Livade neighborhood was developed according to *Detailed zoning plan of "Krive livade" housing estate, 1978* (Fig. 1a).

Krive Livade neighbourhood was planned as a self-sufficient unit consisting of residential buildings with 1.860 apartments, public services, commercial facilities and public open spaces. Public services and facilities (school, kindergarten, public administration) were concentrated in central part of the neighborhood. Commercial facilities in form of ground-floor annexes next to residential buildings were mostly located along the Boulevard Nemanjića, thus enclosing the neighborhood towards the busy boulevard and creating more intimate micro-neighborhoods in the inner area.

Being built as a typical LHE, Krive Livade neighborhood shares certain common characteristics of LHEs:

- development along the city boulevard well connected to the city center;
- centrally positioned public facilities, accessible to all residents within walking distance (see Fig. 1a: A,B,C,D - housing; MZ - municipal building; DU - kindergarten; ŠK - school)
- symmetry in design - central axis divides the neighborhood in two almost completely symmetrical parts (see Fig 1a, b: building blocks A and B)

- high-rise buildings (five to twelve storeys);
- repetition of buildings and building assemblies;
- separation of traffic flows – car traffic on the perimeter of the neighborhood and pedestrian traffic in inner area;
- high share of public open space and green areas;
- spatial homogeneity of the neighborhood, unhindered by car traffic;
- housing development that is not accompanied by development of public and commercial services and amenities;
- monofunctionality at building and neighborhood level.



Figure 1: a) Detailed urban plan for the neighborhood Krive Livade (1978); b) Layout of the neighborhood in 2006

Transformation of Krive Livade neighborhood started in early 1990s, almost as soon as it was built. Similar to other LHE, a part of land intended for public facilities remained unbuilt (school and local community building) and later repurposed in favor of commercial uses. Zona III commercial center, new commercial development on land previously intended for public uses, represent one of first transformations of Krive Livade neighborhood. It was developed by a state construction company in early 1990s and all of the premises were sold to a large number of private property owners on the open market [28].

Two main drivers of neighborhood transformation were: privatization of public housing stock, in initial phase; and land restitution in later phase of transition. Privatization of socially owned apartments in Serbia began in 1990 with the adoption of the *Law on Housing Relations*<sup>6</sup>, while the restitution process began much later, in 2011, with the adoption of the *Law on Restitution of Confiscated Property and Compensation*<sup>7</sup> [24]. Housing privatization and land restitution, combined with the strengthening of private capital, have greatly influenced the transformation of LHEs.

The first, initial phase of the transition was marked with deep economic crisis, almost complete privatization of public housing stock, withdrawal of public sector from housing construction and weak private sector. These conditions directly influenced the appearance of the two most pronounced transformations: 1) multi-

<sup>6</sup> "Official Gazette of the RS", No. 12/90, 47/90, 55/90 and "Official Gazette of the RS", No. 3/90 and 7/90

<sup>7</sup> "Official Gazette of RS", No. 72/2011, 108/2013, 142/2014 and 88/2015



storey housing extensions, i.e. construction on the host building (Fig. 2) - more than 60% of existing buildings in Krive Livade neighborhood were upgraded [29]; and 2) garage capitalism - transformation and adaptation of ground floor of buildings into a space for retailing and other services.

Although spontaneous and privately initiated, the interventions were supported by planning documents and legislation. The *General urban plan of the City of Niš* (1995-2010) allowed, and even suggested, the increase in housing stock by upgrading the existing buildings. On the other hand, the construction on the land between the existing buildings was not allowed. The Plan treated LHEs as built-up areas of high density, without possibility for further construction between existing buildings. However, residential and commercial buildings appeared in the form of infill construction, on the land previously intended for public uses, education and administration (Fig. 2).



Figure 2: Post-socialist transformations of Krive Livade neighborhood: MSE – multi-story housing extensions; RID – residential infill dev.; CID – commercial infill dev.

The later phase, that continues to this day, is marked with changes in planning methodology and planning documents, strengthening of private capital, beginning of land restitution, changes in land ownership and land market, which all created the conditions for further transformations.

As opposed to detailed zoning plans for LHEs from the socialist period, recent planning documents don't recognize LHE as a whole, not even as a built-up area. LHEs are usually treated as high-density residential zones, with no maximum density defined, thus enabling additional construction on free land. LHEs, with high share of public open space and greenery and large distances between buildings, become suitable locations for further development. New infill housing development is currently the most prominent transformation in Krive Livade neighborhood.

Quantitative and qualitative reduction of public open spaces is present from the very beginning of the transition in two forms: 1) formal change - restitution of land (return of unbuilt land to pre-war private owners) and (2) informal changes – "ad-hoc" appropriation of public open space for private uses [27]. In addition to land

occupation by buildings, new infill development also caused the introduction of car traffic into inner area and spatial fragmentation of the neighborhood.

Krive Livade neighborhood, and Bulevar Nemnjića LHE as a whole, experienced significant transformations that started back in socialist period and intensified through the transition period in form of uncontrolled and uncoordinated individual interventions, mostly supported by planning documents and legislation.

#### 4.2. Cerak Vinogradi, Belgrade

Cerak – Vinogradi LHE (Cerak 1 and Cerak 2) in Belgrade was built in the period from 1978 to 1985 [30], funded jointly by the Yugoslav Peoples Army and the Housing Interest Community of Belgrade. The authors of the project selected at the Yugoslav invitational competition in 1977, were architects Darko Marušić, Milenija Marušić and Nedeljko Borovnica,.

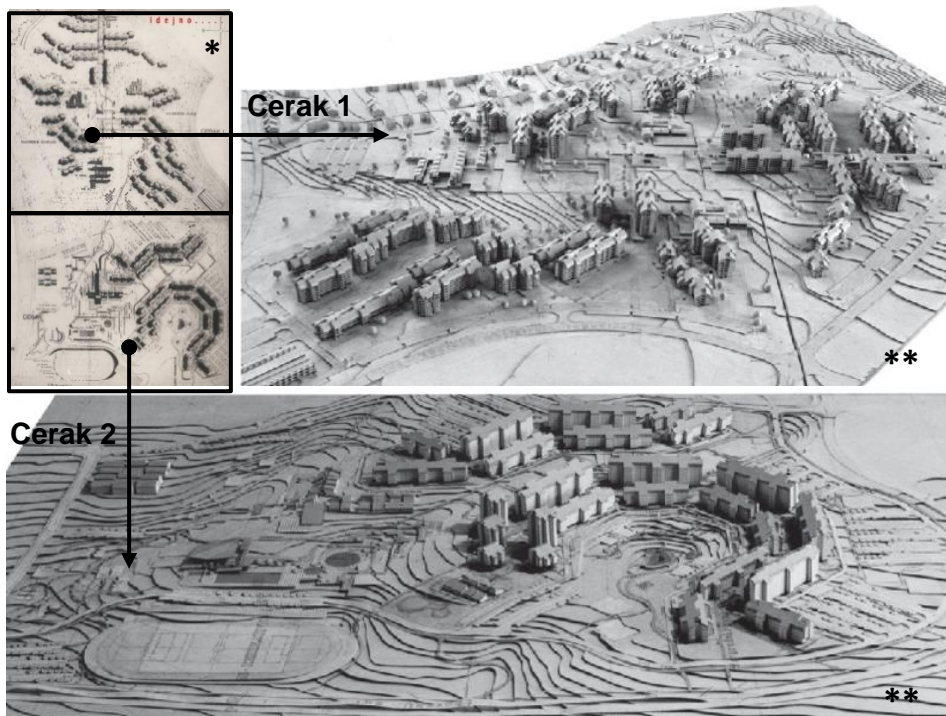


Figure 3: Cerak Vinogradi: model showing Cerak 1 (up) and Cerak 2 (down). Source: <https://www.vreme.com/vreme/cekajuci-cekacke-ptice/>; \*\*Kušić & Blagojević, (2013)

The first phase of the LHE construction - Cerak 1 (Fig. 3) covered the area of 58 ha and was planned for 8,500 residents. It consisted of organic arrangement of buildings around pedestrian circulation and open spaces [31]. The project envisaged three levels of community integration: 1) pedestrian streets, 2) neighborhoods and 3) the settlement; to provide the identification with the environment and active communal life [31, 32]. The second phase - Cerak 2 (Fig. 3), was planned for 3,600 and covered the area of approx. 35 ha. In this phase, the authors introduced an amphitheater formed by the circular arrangement of the urban plan and two innovations: urban gardening and a center for interaction between suppliers, design professionals, and existing and future resident [31, 32]. The settlement is organized on the principle of neighborhood units. As stated by the authors [32] one center of

the settlement was not suitable in terms of the organization of a homogeneous whole, primarily because of the problem of distance and the size ratio of central activities tissue and residential tissue. Therefore, they introduced neighborhood units and centers of neighborhood units spatially positioned as the meeting point of pedestrian flows. In 1981, along with the first completed buildings, the authors received the City of Belgrade October Award for this project.

Similar to other LHEs, Cerak Vinogradi experienced some transformations both in socialist and in post-socialist period, including cordoning gardens, appropriation of pedestrian passageways, and glazing or closing of loggias. As early as 1982, the architects started lobbying the municipal and investor services to help put a stop to the illegal changes executed daily on residential buildings [31]. As stated by authors, areas allocated for urban gardening were in fact planned for the so called "central functions": sports-center and multi-storey car park and the allotments for gardening were only thought of as a preventive strike against illegal or spontaneous construction in the part of the estate not planned for development in the immediate future [31].

Despite visible changes, even during the construction period, the authors claim that a "golden age" of Cerak Vinogradi LHE was the period between 1983 and 2003, when there was a local community that took care of the neighborhood [33]. During the post-socialist period, the neighborhood became a site of frequent illegal interventions in public open spaces and on the top of the roofs, exercised with the tacit approval of the authorities [31].

Similar to previous example, recent urban plan - General zoning plan of the City of Belgrade (Units I - XIX) adopted in 2016, didn't recognize the Cerak Vinogradi LHE as spatial and functional unit. According to the Plan, the area was divided into different land uses: green areas, areas for facilities and complexes of public services, traffic areas and residential areas i.e. "groupings of open building blocks" [34].

After the exhibition "Toward a concrete utopia: the architecture of Yugoslavia 1948-1980" in January 2019, Cerak Vinogradi LHE has been selected as part of the MoMA museum's permanent collection [35, 36]. The same year the LHE was declared as a spatial, cultural and historical unit by the decision of the Government of the Republic of Serbia and officially included in the Central Register of Cultural Properties of the Republic of Serbia. As stated in the Decision on declaration, the spatial cultural-historical unit represents a synthesis of urban, architectural and construction methods as a kind of "experiment" and a reaction to the previous anonymity of public space and the rapid, schematized and mass construction of typical buildings and settlements in Belgrade [37]. Although it has undergone certain changes in the buildings and public open spaces, it can be said that the Cerak Vinogradi LHE avoided dramatic changes and preserved its spatial and functional characteristics, for which it was declared a cultural property.

After being declared a cultural property, in 2019, one of the authors, Milenija Marušić, with the participation of the tenants, created a document called the *Development Strategy for Reconstruction, Revitalization and Management Models in the Cerak-Vinogradi settlement* [32], which was forwarded to municipal, city and republican institutions. As explained by the author [38] the document proposed three lines of activity: 1) reconstruction and revitalization of the settlement, i.e. repair and restoration of buildings, ruined by non-maintenance and illegal interventions, to their original state; as well as construction of designed, but unbuilt part of the LHE; 2)

programming of future activities and contents, and 3) management model for the maintenance of the settlement by forming an independent institution. This initiative, although without a response from the public authorities, represents an attempt to create a public strategy for managing the development of LHE in the post-socialist period.

## 5. CONCLUSIONS

Large housing estates represent one of the most striking spatial legacies of socialism. In the period of post-socialism, these settlements underwent numerous transformations conditioned by the transition path of each country, but also by the characteristics of the settlements themselves. Some LHEs have experienced total neglect and decay. On the other hand, some of LHE underwent uncontrolled and uncoordinated development, based on individual actions aimed at improving housing conditions. Finally, there are examples of LHEs fully renovated through different urban regeneration projects. As for development strategies, a review of the literature established the existence of three strategies: "doing nothing" strategy, extreme strategy – wholesale demolition of existing housing stock; and integral strategy aimed at revitalization and regeneration of existing LHEs. Post-socialist development of LHEs in Serbia takes place mainly in an uncontrolled and uncoordinated manner, without an integral public strategy.

The paper presented two examples of post-socialist development of LHE in Serbia, both based on individual strategies, but with different outcomes. The first one, Krive Livade neighborhood, is typical example of uncontrolled and uncoordinated development aimed at achieving profit, supported by planning documents and legislative. As a result, the neighborhood experienced significant changes in form of building upgrades, residential and commercial infill development, garage capitalism, fragmentation and reduction of green areas; it lost its identity, spatial homogeneity and some of the essential features that made it recognizable.

Another example, Cerak Vinogradi LHE points out the efforts and initiatives of the individuals, in this case the authors of the project, aimed at preservation of the LHE concept through the period of dramatic changes in the post-socialism. Although Cerak Vinogradi also experienced some changes to buildings and open spaces, they remained minor in comparison to the spatial coverage of the settlement. The LHE has mostly preserved its original form, for which it was declared as cultural property of the Republic of Serbia.

The research has shown that in the absence of public development strategies, private strategies come to the fore. Both cases confirm the main characteristic of the post-socialist LHE development in Serbia – lack of integral strategy and development based on individual strategies. The analyzed cases indicate the need for public development strategies, in order to prevent further unfavorable changes and degradation of the quality of life in LHEs. Bearing in mind that the current state of inherited LHEs depends on a number of factors, it is necessary to analyze different types of LHEs and define appropriate strategies for future development.

## REFERENCES

- [1] Hegedüs, József, Tosics Iván: **The disintegration of the East European housing model**, *Housing Privatisation in Eastern Europe*, 15-40, 1996.
- [2] Hirt Sonia: **Whatever happened to the (post) socialist city?** *Cities* 32, S29-S38, 2013.
- [3] Hirt Sonia, Stanilov Kiril: **Twenty Years of Transition: The Evolution of Urban Planning in Eastern Europe and the Former Soviet Union, 1989-2009**. *Nairobi: UN-HABITAT, 2009*.
- [4] Tosics, Ivan: **European urban development: Sustainability and the role of housing**, *Journal of Housing and the Built Environment*, 19(1), pp. 67-9,. 2004.
- [5] Stanilov Kiril: **Housing trends in Central and Eastern European cities during and after the period of transition**. *The post-socialist city*. pp. 173-190, 2007.
- [6] Hirt, Sonia: **Iron curtains: Gates, suburbs and privatization of space in the post-socialist city**. Vol. 27. John Wiley & Sons, 2012.
- [7] Banerjee, Tridib: **Beijing, Berlin and Bucharest: Legacies of socialist modernity at the end of history**. *11th Conference of the International Planning History Society, July*, vol. 1417. 2004.
- [8] Enyedi, György: **Urbanization under socialism**. *Cities after socialism*, Oxford: Blackwell Publishers Ltd, pp. 100-118, 1996.
- [9] Musil Jiří: **Changing urban systems in post-communist societies in Central Europe: analysis and prediction**, *Urban studies*, 30(6), pp. 899-905, 1993.
- [10] Hirt Sonia, Kovachev Atanass: **The changing spatial structure of post-socialist Sofia**. *The Urban Mosaic of Post-Socialist Europe*, pp.113-130, 2006.
- [11] Treija Sandra, Bratuškins Uģis: **Socialist Ideals and Physical Reality: Large Housing Estates in Riga, Latvia**. *Housing Estates in the Baltic Countries*. Cham: Springer, pp. 161-180, 2019.
- [12] Tuvikene Tauri: **Between community and private ownership in centrally planned residential space: governing parking in socialist housing estates**. In: *Housing Estates in the Baltic Countries*. Cham: Springer, pp. 321-336, 2019.
- [13] Grava, Sigurd: **Urban transport in the Baltic republics**. In *The post-socialist city: urban form and space transformations in Central and Eastern Europe after socialism*, Dordrecht: Springer Netherlands, pp. 313-343, 2007.
- [14] Mojovic Djordje: **Serbia** in *Management of privatised housing: International policies and practice*. John Wiley & Sons, pp. 211-227, 2009.
- [15] Sýkora, Luděk: **Local urban restructuring as a mirror of globalisation processes: Prague in the 1990s**. *Urban Studies* 31, no. 7, 1149-1166, 1994.
- [16] Tosics, Iván: **City development in Central and Eastern Europe since 1990: The impacts of internal forces**. *Transformation of cities in Central and Eastern Europe: Towards globalization*, 44-78, 2005.
- [17] Tsenkova Sasha: **The housing policy nexus and people's responses to housing challenges in postcommunist cities**. *Urbani Izziv*, 25(2), pp. 90-106, 2014.
- [18] Ouředníček Martin, Špačková Petra, Pospíšilová Lucie: **Long-term development and current socio-spatial differentiation of housing estates in Prague, Czechia**. *Housing estates in Europe: Poverty, ethnic segregation and policy challenges*, 339-359, 2018.
- [19] Leetmaa, Kadri, Holvandus Johanna, Mägi Kadi, Kährik Anneli: **Population shifts and urban policies in housing estates of Tallinn, Estonia**. *Housing estates in Europe*, 389, 2018.
- [20] Vasilevska, Ljiljana, Zivkovic Jelena, Vasilevska Magdalena, Lalovic Ksenija: **Revealing the relationship between city size and spatial transformation of**

- large housing estates in post-socialist Serbia.** *Journal of Housing and the Built Environment* 35, 1099-1121, 2020.
- [21] Hess Daniel Baldwin, Tammaru Tiit, Van Ham Maarten: **Lessons learned from a pan-European study of large housing estates: Origin, trajectories of change and future prospects.** *Housing estates in Europe: Poverty, ethnic segregation and policy challenges*, 3-31, 2018.
- [22] Marin Vera, Chelcea Liviu: **The many (still) functional housing estates of Bucharest, Romania: A viable housing provider in Europe's densest capital city.** *Housing estates in Europe: Poverty, ethnic segregation and policy challenges*, 167-190, 2018.
- [23] Luhn Alec: **Moscow's big move: is this the biggest urban demolition project ever.** *The Guardian: Cities*, 2017.
- [24] Đekić, Jelena, Vasilevska Ljiljana: **Characteristics of multifamily housing development in the post-socialist period: Case study, the city of Niš.** *Facta Universitatis, Series: Architecture and Civil Engineering*, 245-260, 2021.
- [25] Vujošević Miodrag, Zeković Slavka, Maričić Tamara: **Post-socialist transition in Serbia and its unsustainable path.** *European planning studies* 20, no. 10, 1707-1727, 2012.
- [26] Vasilevska Ljiljana, Milanovic Danijela, Nikolic Marko, Vranic Petar, Milojkovic Aleksandar: **„Garage capitalism” as a form and process of post-socialist urban changes: Its pace, intensity and structural characteristics. A case study of Nis, Serbia.** *Habitat International* 48, 149-158, 2015.
- [27] Đekić Jelena: **Uticaj promena fizičke i funkcionalne strukture područja višespratnog stanovanja na kvalitet života stanovnika u uslovima postsocijalističke transformacije na primeru grada Niša,** докторска дисертација, *Универзитет у Нишу*, 2022.
- [28] Dinic Brankovic Milena, Djekic Jelena, Mitkovic Mihailo, Mitkovic Petar, and Markovic-Brankovic Jelena: **Postsocialist restructuring of city subcenters and the role of shopping centers in Nis, Serbia.** *Journal of Urban Planning and Development* 144, no. 2, 04018009, 2018.
- [29] Đekić Jelena, Dinić Branković Milena, Igić Milica, Ljubenović Milica, Mitković Mihailo: **The impact of post-socialist transformations on multifamily housing: A case study Niš, Serbia.** *ICUP2022*, Niš, 263-273, 2022.
- [30] [https://beogradskonasledje.rs/katalog\\_kd/naselje-cerak-vinogradi-cerak-1-i-cerak-2](https://beogradskonasledje.rs/katalog_kd/naselje-cerak-vinogradi-cerak-1-i-cerak-2)
- [31] Kušić Aleksandar, Blagojević Ljiljana: **Patterns of everyday spatiality: Belgrade in the 1980s and its post-socialist outcome.** *Český Lid*, 281-302, 2013
- [32] Марушић Миленија: **Надградња програмских услова за насеље Церак Виногради у Београду, АРХИТЕКТУРА И УРБАНИЗАМ - СПЕЦИЈАЛНИ БРОЈ – 2019,** стр. 18-26, 2019.
- [33] <https://www.politika.rs/sr/clanak/477303/Ko-ce-spasti-naselje-Cerak-vinogradi>
- [34] PGR građevinskog područja sedišta jedinice lokalne samouprave – Grad Beograd (Celine I – XIX); [https://www.urbel.com/planovi/pgr/PGR\\_BGD\\_2016.pdf](https://www.urbel.com/planovi/pgr/PGR_BGD_2016.pdf)
- [35] Јевтић Милорад: **Врхунски дometri ауторског пара Миленије и Дарка Марушића под окриљем ИАУС-а. АРХИТЕКТУРА И УРБАНИЗАМ** 49, стр. 77-81, 2019.
- [36] <https://www.moma.org/collection/works/221534>
- [37] Одлука о утврђивању насеља Церак-Виногради (Церак 1 и Церак 2) у Београду за просторну културно-историјску целину ("Сл. гласник РС", бр. 4 /2019).
- [38] <https://www.danas.rs/vesti/drustvo/milenija-marusic-naselje-cerak-vinogradi-nije-samo-projekat-to-je-poduhvat/>

## "ERASING" THE BOUNDARY BETWEEN INTERNAL AND EXTERNAL SPACES IN PRESCHOOL FACILITIES

Aleksandra Rančić<sup>1</sup>, Danica Stanković<sup>2</sup>, Aleksandra Cvetanović<sup>3</sup>

### Abstract

*The reality is that even preschool children in the modern age spend an excessive amount of time indoors, utilizing a plethora of digital devices. There is widespread recognition that children's exposure to a natural environment and nature-derived environment settings is fundamental for the enhancement of physical-sensory, socio-emotional, and mental development of preschoolers. Preschool institutions play a pivotal role in early childhood growth and development, as they provide a healthy foundation for future learning and action. Due to the multiple importance that preschool institutions have in the initial stages of children's growth and given the considerable duration of time that children spend in these structures, it is essential to reassess and enhance the features of the preschool space and the surrounding area, as well as their interrelationship, that are closely related to children's health, well-being, psychophysical development and effectively stimulate senses and activate the learning process. Therefore, this research endeavors to reconsider the boundary between the external and internal space of preschool buildings and establish design principles that will intertwine these spaces in order to create a healthier and more stimulating environment that meets the interests and needs of children. The research aims to revive the quality of time spent in preschool space by "blurring" the boundary between internal and external spaces and enhancing the properties of space through the integration of natural elements. The primary objective of this study is to formulate design strategies that improve the properties of space in preschool buildings, creating a stimulating ecological environment that can support the healthy stay of children.*

**Key words:** *Preschool building, natural environment, internal and external space, boundary, children development*

---

<sup>1</sup> MSc. Arch., PhD. student, Teaching Assistant, Public Buildings Department, Faculty of Civil Engineering and Architecture, University of Nis, Serbia, aleksandra.rancic@gaf.ni.ac.rs

<sup>2</sup> PhD., Professor, Public Buildings Department, Faculty of Civil Engineering and Architecture, University of Nis, Serbia, danica.stankovic@gaf.ni.ac.rs

<sup>3</sup> MSc. Arch., PhD. student, Teaching Associate, Public Buildings Department, Faculty of Civil Engineering and Architecture, University of Nis, Serbia, aleksandra.cvetanovic@gaf.ni.ac.rs

## 1. INTRODUCTION

The early years represent a crucial stage in children's development, characterized by its strong association with subsequent behavioral and action patterns. The characteristics of the environment in which children reside play a vital role in facilitating their proper growth and development. Alongside the family environment, the preschool setting emerges as a prominent component of their everyday lives, given the substantial duration of time they spend within preschool institutions. Transition of the society caused by technological progress impacts on children' taste of nature. Even preschool children in the modern age excessively spend their time indoors, engaging with various electronic devices. The increasing disconnection between children and nature is a concern that resonates throughout the world. Numerous authors have pointed out the consequences of the weakened connection between children and the natural environment. Louv emphasizes that Nature Deficit disorder is the human cost of being alienated from nature, and includes attention disorders, learning difficulties and increasing rates of physical illnesses and mental health issues [1]. Connection to nature can, in turn, promote happiness [2] and well-being [3], among other beneficial cognitive, psychological, and physiological outcomes [4,5]. The children's development is highly dependent on the qualitative properties of the designed environment, including the features of the physical structure and its layers, equipment and furniture. The specific types of children play require certain features of the space. In light of the aforementioned, it has become imperative to reevaluate the demarcation between the external and internal spaces within preschool facilities, and to deliberate and develop methodologies that will facilitate the integration of the outdoor and indoor realms, ultimately aiming to fulfill the requirements of the primary users, children, for a conducive and enhanced environment that fosters their well-being and overall development.

The research tends to enhance the quality of time spent in preschool environment by "erasing" the limit between internal and external spaces and improving the properties of space through the integration of natural elements. The emphasis of this study is placed on devising methodologies and design solutions that will create such attributes of preschool space that it cannot be precisely classified as either external or internal, but rather as a hybrid and nature-based environment. After analyzing and examining selected foreign experiences in the field of preschool building design, which are grounded in a framework of spatial attributes that facilitate intimate engagement with the natural environment, a selection of naturalistic characteristics observed in the examined facilities has been identified. The primary objective of this study is to formulate design strategies that improve the properties of space in preschool buildings, fostering a more intensive contact with nature and creating a stimulating ecological environment that can support the healthy stay of children.

## 2. METHODOLOGY

To establish a new standard in the design and construction of preschool buildings with a "soft and flexible skin", incorporating indoor spaces that emulate outdoor environments and foster the health and well-being of children through more frequent contact with the natural world, this research entails an analysis of current literature



emphasizing the significance of children's interaction with the external natural environment. Additionally, it explores emerging trends in the design of preschool facilities and examines completed buildings characterized by high flexibility and nature-based features.

The initial step encompassed a thorough investigation of the demarcation line separating the external and internal domains. Subsequently, a comprehensive analysis of foreign practices was conducted using analytical methods to identify existing design solutions that exemplify qualities such as fluidity, flexibility, naturalness, and effective visual and acoustic integration with elements of nature, while adhering to the principles of a naturalistic approach. The aforementioned analyses were done with the aim to form set of principles with specific measures that will be widely applicable to design practice on the territory of Serbia. After analyzing the selected samples, a synthesis of the applied principles that generated a space without boundaries and with naturally ecological properties was conducted. Main conclusion and final observations are presented at the end of the paper.

### **3. RESULTS**

The research results are categorized into three subchapters, providing a comprehensive analysis of the findings. Each subchapter focuses on a specific aspect of the research, aiming to explore and present a detailed understanding of the topic. The subchapters cover key areas such as data analysis, interpretation of findings, and implications for future research. The division into subchapters allows for a structured and systematic presentation of the research results, facilitating a deeper comprehension of the study's outcomes.

#### **3.1. Benefits generated by children's staying in nature**

The reasons necessitating the elimination of the boundary between the exterior and interior, and the integration of the external natural environment with the building's interior, are diverse and grounded in extensive research. In recent years, numerous researchers have delved into the relationship between children and nature, approaching it from various angles and investigating the potential advantages and benefits associated with prolonged exposure to natural environments. Natural environment is considered as the most appropriate place for children play and other activities. Generally, natural play spaces provide children a full spectrum of benefits, satisfaction of educational, physical, social and emotional needs. Nowadays generation of children do not sense natural world as much as in the past. Research showed that green spaces and just viewing nature scenes have a positive influence on well-being. The positive effects of nature exposure include improved cognitive functioning (including increased concentration, greater attention capacities, and higher academic performance), better motor coordination, reduced stress levels, promote social behavior - increased social interaction with adults and other children, and improved social skills [6]. Keeler described the natural world act as "a great friend and teacher to young children" because it "offers infinite opportunities for wonder and learning, with surprises around every corner" [7].

The natural elements or organic settings shaped by human influence provide a space for children to engage, fostering their initiative, autonomy, and creativity.

When children have frequent and diverse opportunities for free and unstructured play in outdoor environments, they exhibit enhanced intelligence, cooperation, happiness, and overall well-being. Nature-based environments inclusively accommodate children of all physical abilities, while simultaneously inspiring and challenging them to take calculated risks. The children act as architects of both the physical and the imaginary and interact extensively with raw materials. They build shelters, transform stones and snow into toys, and they build airports in the trees. [8].

The physical benefits of outdoor play, whether in natural or man-made green settings, are evident and contribute to the prevention of childhood obesity. These environments provide dynamic and active spaces that enhance sensory awareness and stimulate the development of children's gross and fine motor skills. Engaging in outdoor play promotes fitness, health, strength, and endurance. According to Von Benzon, the literature recognizes a variety of benefits associated with providing access to outdoor green spaces, extending beyond the psychological realm [9]. Interaction with the outdoor environment without any boundaries could diminish psychological pressure in our daily life. Nature has the potential to alleviate mental stress and illness [10]. Natural England stated that children will do better than usual after activities in green settings and that the "greener" a child's play area, the less severe his or her attention deficit symptoms. [11]. From a social perspective, children can learn to collaborate, assume responsibilities, develop self-confidence, foster cooperation, and establish a teacher-student relationship while engaging in nature-based learning [12]. According to Hashim & Denan, nature provides a peaceful and motivating environment and stimulates knowledge seeking, curiosity and attentiveness [10]. It is important for children to be in an outdoor environment for the development of motor and cognitive skills. In an outdoor environment, children can learn through three modes of learning which are cognitive, affection, and the evaluation of either natural or man-made things. [13] Outdoor environments, particularly diverse natural settings with a variety of plants and landscapes, encourage children to embrace their natural curiosity. With a multitude of things to explore and question, these environments provide a uniquely captivating space for unstructured play. In addition to these benefits, children's innate curiosity also fosters scientific learning, including not only the acquisition of specific knowledge about nature but also an understanding of the scientific method.

### **3.2. Outside-inside relationships**

This part of the study addresses the issue of the relationship and demarcation between the external and internal spaces, as well as the potentials offered by the integration of these zones. The physical environment plays a pivotal role in shaping the behavioral patterns and actions of its inhabitants. The interplay between the exterior and interior constitutes a crucial aspect within the realm of architecture. Throughout history, humans have exhibited a proclivity for preserving a segment of the external space to establish a distinct internal realm. Architects endeavor to explore and delineate the relationship between the exterior and interior domains. They manipulate the external mass, internal space, and their boundaries, employing design techniques that foster a seamless connection between the interior and exterior spaces. Groter mentioned the importance of the relationships between outdoor and indoor, which should include integrational relations [14]. Sedaghat,

Khakpour, and Vahidi explained that the relationship between outdoor and indoor can be in three types, which are; visual, audio, and availability [15]. The entire contemplation of designing the boundary between the exterior and interior envelope that forms a space is directed towards establishing specific qualitative and quantitative attributes that correspond to the end users, thereby ensuring general well-being and enhancing health and growth. The architectural experience often involves the separation of the external space from the interior. Occasional encounters between these segments occur through windows, doors, or other architectural partitions. Such separation is a necessary requirement for certain areas, as much can be achieved through a design that distinguishes the exterior from the interior. However, the question arises: what happens when the skin of architecture disappears? If it becomes transparent, what does it mean for the occupants within?

The interior of the physical structure of the pre-school community is more than a shelter and space intended for a different type of children's activities (playing, learning, working, socializing, etc.). It is a powerful entity that conveys values and messages and is an essential element of children growing up in pre-school age. This importance clearly indicates the activities in the direction of shaping the environment, not only in terms of its creativity and stimulating effect for children's growth and development, but also in the context of their health. The design of the envelope for preschool buildings, incorporating both transparent and solid parts, must prioritize the creation of a secure and stable primary dwelling. It should offer protection against weather conditions, while fulfilling hygrothermal requirements and adhering to standards of air cleanliness and hygiene. In spaces primarily utilized by children, it is crucial to address various sensory aspects, including acoustic, visual, and tactile qualities, as well as aesthetic considerations and dynamic characteristics. Additionally, the envelope should be adaptable to specific needs such as appropriate number, size, geometry, and spatial relationships, allowing for flexibility in usage. These requirements are directly linked to the growth and development of children. The provision of hygienic and technical conditions within the preschool space depends on the qualitative and quantitative properties of the transparent and solid envelope, the structural composition of the envelope, and the overall architectural organization of the space.

Transforming the facade envelope into a transparent membrane within areas actively used by children, such as kindergarten classrooms and multipurpose spaces, increases children's exposure to the natural environment and encourages more active engagement with the outdoor open spaces. Specifically, in moderate climate conditions, kindergarten classrooms should have a higher intake of natural daylight. In accordance with applicable regulations in Serbia, all rooms for children must have sufficient access to natural daylight. During the summer, it is necessary to ensure maximum diffusion of light and minimal direct sunlight penetration by using shades and curtains. The window area should average around 1/5 of the floor area [16]. In addition to meeting the minimum prescribed window area, the design of the window openings is also crucial for the facade envelope of preschool institutions.


Integrating the natural environment into interior design is a fundamental aspect that anchors the preschool space within its surrounding landscape. By establishing a connection between indoor and outdoor spaces, a sense of continuity is achieved, offering contextual relevance and harnessing the numerous mental, physical, and





emotional health benefits associated with biophilic design. Moreover, nature-inspired interior design holds timeless appeal due to the universal attraction to organic materials, earthy color palettes, and other natural elements. The seamless integration of exterior and interior design plays a significant role in creating an aesthetically pleasing and captivating environment. Groter pointed out that the relationship between the interior and exterior provides an opportunity for movement, accessibility, and environmental connection [14]. Krstić et al. find the relationships between the interior and exterior space in term of spatial layers of the buildings, which depends on the core, structure, and layout of the architectural buildings. The researchers explained the relationship as 'in Between' virtual place connected the interior to exterior and included characteristics from each side [17].

### 3.3. Analysis of foreign practice examples

Positive designed solutions and examples of environmental, sustainable buildings of this type around the world, can serve as role-models for managing in further design-architectural activity. This section presents an overview of implemented solutions that partially or completely fulfill the criteria for creating a blended indoor-outdoor natural environment, using the analysis method.

Table 1. Review of selected constructed buildings from foreign practices.

Preschool building / Location / Year of construction / Architect	Characteristic of designed solution / applied naturalistic principles
<p><b>1. Fuji kindergarten/</b> Tokyo Japan /2007/ Tezuka Architects</p>  <p><a href="http://www.tezuka-arch.com/">http://www.tezuka-arch.com/</a></p>	<p>The Fuji Kindergarten is a single-story, oval-shaped building that encourages children to play and interact by breaking down the physical barriers found in the typical early childhood educational architecture. With no physical boundaries in the classroom, the kindergarten has been designed as a continuous space. The interior is an integrated space softly partitioned with furniture. Building design with open spaces and greenery inside allowing children to play and explore nature. Large sliding glazed doors lining the interior of the ring are opened up for a majority of the year, allowing children to freely pass between indoor and outdoor areas, encouraging independence and socialization. An accessible roof becomes the main play space for the school, giving students an endless path to run, jump and play.</p>
<p><b>2.Yutaka Kindergarten /</b> Saitama, Japan /2014 / SUGAWARADAI SUKE Architects</p>  <p><a href="https://www.archdaily.com">https://www.archdaily.com</a></p>	<p>In order to respond to its needs, architects traced the word "kindergarten" to its origin - "children's garden" - and converted the site into mosaic-like collection of gardens for diverse activities of children. The three gardens are developed seamlessly on the site, which allows children of different age and body capabilities to coexist, interact, or be separated. The exterior environment are planned to become a forest of biodiversity to contribute to the education program, and as they change their expression every season and also during the day, the ceiling reflects and absorbs them to the interior. It is essential to perceive the transitions of natural environment as infants generate and expand their perception. Variety of gardens expanded indoors and outdoors, stimulates human instincts to search for adequate environment, developing infant perceptions and experiences.</p>
<p><b>3. Nursery /</b> Guastalla, Italy/ 2015/ Mario Cucinella Architects</p>	<p>Design solution stimulates the child's interaction with the surrounding space and establishes the integration between indoor and outside space (large transparent surfaces- glass panels). Architectural</p>

 <p><a href="https://www.archdaily.com">https://www.archdaily.com</a></p>	<p>elements of the new kindergarten like the shape of the interior, their organization, the choice of materials, all the sensory perceptions related to the light, the colours, the sounds, the tactile suggestions - are designed taking into account of the pedagogical and educational related to the growth of the child. The structure involves the use of natural materials with low environmental impact (peculiar wooden ribs: a safe and ideal material to keep the thermal insulation of the building; visually, a gallery of such curved arches creates the illusion of an endless cave).</p>
<p><b>4. HN Nursery /</b> Kanagawa Prefecture, Japan / 2017/ Hibinosekkei + Youji no Shiro</p>  <p><a href="https://www.archdaily.com">https://www.archdaily.com</a></p>	<p>The nursery is planned to design where children can feel nature in a whole day, and play excited and stimulating, so that they can develop their sensibility and creativity. Children can feel a lot of things, such as the warmth from sunlight, the touch of soil, the smell of flower, the color of sky. For the aim that they take such a full of nature activity in a whole day and then make a discovery and think by themselves, this nursery is designed as they can feel nature whenever and wherever they are. In a nursery room, there is a big banyan tree planted from ground, where children can enjoy climbing tree. From the roof made of glass, the sunlight comes and they can watch the floating clouds in the sky. In the playground, there is a big hill with 5-meter difference in height and there children can feel the touch of ground from infants who crawl and they can get many physical activities by rolling over and over, slipping, digging...</p>
<p><b>5. My Montessori Garden</b> Ha Long City, Vietnam/ 2020/ HGAA</p>  <p><a href="https://www.archdaily.com">https://www.archdaily.com</a></p>	<p>My Montessori Garden is a Montessori-oriented preschool. Kindergarten is shaped as garden - a natural space for children, a classroom between the trees and flowers. They can run around and look at the plants, touch them and watch them grow every day. In this garden, children can learn how to plant and care for fruit vines, seasonal vegetables, and their favorite flowers. More than 50% of the land is used as garden, to create a learning space close to nature in which children can learn, connect and interact with nature more often than the regular classes. In terms of micro-climate, the tree garden surrounding the classroom also creates a cool and quiet atmosphere for the classrooms, while creating views and green landscapes for all classes. In an effort to seek change from simple but bold architectural solutions - creating a classroom in the middle of a garden right in the heart of the city, we hope to contribute to improving the quality of educational spaces, inspire the next changes.</p>
<p><b>6. MS kindergarten /</b> Maebashi, Japan / 2021 / Hibinosekkei, Kids Design Labo, Youji no Shiro</p>  <p><a href="https://www.archdaily.com">https://www.archdaily.com</a></p>	<p>The environment incorporates elements of traditional Japanese houses, designed to harmonize with nature. Deep eaves and large windows capture varying wind and sunlight throughout the seasons. Mud walls provide insulation and regulate moisture, allowing children to experience nature indoors. The adjoining rooms follow the traditional Japanese style, offering a safe space for children to play under supervision. This comfortable setting allows children to sense the seasons, develop their sensitivity, and engage with local materials and culture. Large glass openings connect indoor and outdoor spaces. Extended eaves provide shade in summer and ample sunlight in winter. Natural tones and textures are featured, with clay-like render and grainy joinery creating a tactile and harmonious atmosphere.</p>
<p><b>7. Forest School Nursery/</b> Stoke-on-Trent, England /2022/ Feilden Clegg Bradley Studios</p>	<p>This net-zero carbon nursery, located near woodlands, offers spaces for children to explore, play, and connect with nature. Daylight is captured through roof lights, aiding natural ventilation.. Aluminum-coated skylights along the rooftop bring in natural light, reducing the need for artificial lighting and aiding ventilation. Openable doors and a shading colonnade minimize energy usage, while heating and</p>



<https://www.dezeen.com/>

cooling are provided by air-source heat pumps and a ground-coupled heat exchanger. The nursery utilizes natural and low-carbon materials, prioritizing bio-based components. The design incorporates low windows, recessed seating, and external benches. The garden doors remain open, seamlessly blending indoor and outdoor teaching spaces while providing solar shading and protection from the elements.

**8. Kindergartens  
Treperka and Waldorf  
Semily/ Semily, Czech  
Republic/2022/ MTa**



<https://www.archdaily.com/>

The aim was to create a building with centralized facilities and a kitchen for two independent two-class kindergartens for children aged three to six. From the center, it is also easy to get an overview of what is happening in or around the kindergarten. The primary role of the service boxes is to articulate the space and to differentiate the rooms intended for the children's stay. This creates a dichotomy between enclosed services and opens serviced spaces. The color scheme is based on Ostwald's chromatic circle and the seven chosen colors refer to the rainbow (red, orange, yellow, green, blue, indigo/purple, violet/pink). The added value is a beautiful and spacious garden with various play elements, divided unobtrusively by a circular mound made of compacted earth from the foundation excavations, used by both kindergartens despite their different learning styles.

The preschool environment should be designed in an "outdoors for everyday life" manner in order to improve children's health by increasing their resistance to environmental allergens, enhancing their activity levels, and achieving other benefits that arise from interacting with the natural environment. In relation to the identified needs of children for specific characteristics of space in previous studies, and considering the current conditions and characteristics of the behavior of children in the modern era, the following features have been highlighted that contemporary preschool design should incorporate:

- Continuity and fluidity: uninterrupted flow between the indoor and outdoor spaces, promoting the integration of the exterior and interior.
- Natural elements: incorporating nature in various forms within both the indoor and outdoor spaces (including greenery, water, sand, stones, trees, and animals).
- Visual connection: allowing for views of the natural surroundings from the interior spaces.
- Building skin: the use of transparent surfaces to enhance the contact between the exterior and interior, dematerializing the boundary between them.
- A building envelope that mimics natural forms: employing a free structure with various windows shapes, creating an inter play of light and shadows within the building.
- Acoustic connectivity: introducing sensory stimuli from the natural environment (birdsong, rustling leaves, wind sounds, insect buzz, water murmurs) into the indoor environment, which can strengthen and refresh brain cells, enhance intellectual capacities, and improve children's emotional states.

## 4. DISCUSSION

This section presents a set of methods for creating boundary-free spaces, creating naturalistic spaces within preschool facilities that offer a fluid flow of children's activities and movements, continuity in vistas, sensory connection with natural elements, boundary-less spaces suitable for a moderately continental climate, and specifically adapted to the territorial area of Serbia:

- Creating intermediate zones between the exterior and interior spaces is an effective strategy for optimizing the relationship between these areas. These intermediate zones can take the form of semi-enclosed transparent areas or greenhouses, incorporating abundant vegetation and other elements that contribute to improved energy efficiency within the built environment. Connecting indoor and outdoor spaces often involves creating transitional spaces that share qualities of both interior and exterior. These spaces establish that connection between indoor and outdoor in a seamless, effortless way that never feels forced.
- Another approach is the integration of large movable transparent panels, which allows for the transformation of the interior space to acquire the qualities and characteristics of the exterior environment when these panels are opened. This adaptable feature enhances the occupants' connection with the surrounding natural elements and provides a dynamic and immersive experience. Besides framing views and facilitating visual communication, windows serve multiple essential functions that make them vital components in any project. They illuminate space with sunrays, provide natural ventilation, filter light, insulate from cold and heat, block water and ensure protection. As most design professionals would agree, glazing also plays a crucial aesthetic role; its materials, style and dimensions certainly make a significant difference in the appearance of facades and spaces. With their clean lines and minimalistic design, these achieve a sleek, elegant look that enhances the aesthetics of contemporary buildings, essentially erasing the boundary between the outdoors and the indoors.
- In the architectural design of the building, a strategic choice is to create an atrium as the central compositional element. This atrium features a movable transparent envelope that is oriented towards an internal courtyard. This deliberate design intervention enables a seamless blending of the indoor and outdoor environments, facilitating the influx of natural light and fostering a sense of vitality and connection with nature within the indoor space.
- Furthermore, the establishment of an interior zone with attributes reminiscent of the exterior space further promotes the integration of the outside environment within the interior. This is achieved through the use of a free envelope that extends from the walls to the ceiling, with carefully designed and proportioned openings. These openings allow for the controlled interaction between the interior and exterior, facilitating visual and sensory connections, and enhancing the overall spatial experience.
- By implementing these design strategies, the built environment can effectively blur the boundaries between the inside and outside, creating a

harmonious and immersive space that promotes well-being, connectivity with nature, and a sense of vitality.

## 5. CONCLUSION

The outcomes of the paper can be generalized for the preschool buildings design in Serbia. The design of the preschool buildings in Serbia needs to re-formulate to reach the users' needs of comfortability, which influences the pupils' action toward their schools. There are numerous benefits to improving the environment in which children reside, spanning from promoting their health and mental well-being to fostering the development of gross and fine motor skills. The research illuminated the important factors of the relationship between interior and exterior space in preschool environment. Promoting the principle of erasing boundaries between the exterior and interior is done with the intention of enhancing the views within the preschool facility, creating a continuous perspective of green landscaped settings. The aim is to create conditions for constant exposure to natural sounds, improve the quality of the microclimate, and activate the exposure to natural elements that foster both gross and fine motor skills development. Visual connection, continuity, and building design are key factors that influence the physical and psychological comfort of children, which in turn affects their behavior. The successful interior design of university buildings evokes feelings of being "at home", a sense of belonging and attachment to the place, and overall comfort. This creates a motivating environment that encourages users to continue their work and occupy the space. The next step in the research involves examining the condition of preschool facilities in Serbia, along with specific proposals for transformation.

## ACKNOWLEDGMENTS

This research was funded by the Ministry of Science, Technological Development and Innovation, Republic of Serbia through Grant Agreement with University of Niš - Faculty of Civil Engineering and Architecture No: 451-03-47/2023-01/ 200095.

## REFERENCES

- [1] Louv Richard: Last Child in the Woods: **Saving Our Children From Nature - deficit Disorder**. Chapel Hill, N.C., Algonquin Books of Chapel Hill, 2008.
- [2] Capaldi Colin, et. al: The relationship between nature connectedness and happiness: A meta-analysis. *Frontiers in Psychology*. Vol. 5, 976, 2014.
- [3] Birch Jo et al: Nature doesn't judge you – how urban nature supports young people's mental health and wellbeing in a diverse UK city. *Health & Place*, Vol.6, 2020.
- [4] Chawla Louise: **Benefits of Nature Contact for Children**. *Journal of Planning Literature*, Vol. 30, No. 4, 433–452, 2015.
- [5] Norwood Francis Michael et al.: A narrative and systematic review of the behavioural, cognitive and emotional effects of passive nature exposure on young people: Evidence for prescribing change. *Landscape and Urban Planning*, Vol.189, 2019, 71-79, 2019.



- [6] Strife Susan, Downey Liam: Childhood Development and Access to Nature: A New Direction for Environmental Inequality Research. *Organ Environ*, Vol. 22 No. 1, 99-122, 2009.
- [7] Keeler Rusty: **Natural playscapes: Creating outdoor play environments for the soul**. Redmond, WA: Exchange Press, 2008.
- [8] Alme Hilde, Reime, Monika Alvestad: **Nature kindergartens: a space for children's participation**. *Journal of Outdoor and Environmental Education*, Vol. 24, 113–131, 2021.
- [9] Von Benzon Nadia: Unruly children in unbounded spaces: School-based nature experiences for urban learning disabled young people in Greater Manchester, *Journal of Rural Studies*, UK, Vol. 51, 240-250, 2017.
- [10] Hashim Haikal Hazman, Denan Zuraini : **Importance of preserving the natural environment in the design schools in Malaysia**. *Procedia - Social and Behavioural Sciences*, 170, 177-186, 2014.
- [11] Natural England: Learning in the natural environment: Review of social and economic benefits and barriers (NECR092). 2012.  
Retrieved from <http://publications.naturalengland.org.uk/publication/1321181>
- [12] Mirrahimi Seyedehzahra et. al: Developing Conducive Sustainable Outdoor Learning: The Impact of Natural environment on Learning, Social and Emotional Intelligence. *Procedia Engineering*, Vol. 20, 389–396, 2011.
- [13] Aziz Nor Fadzila, Said Ismail: **The trends and influential factors of children's use of outdoor environments: A review**. *Procedia - Social and Behavioural Sciences*, Vol. 38, No.5, 204-212, 2012.
- [14] Groter Yurg: *Cosmetology in Architecture*, Translated by: Pakzad, Jahanshah; Homayoun, Abdolreza. Shahid Beheshti University Press. Tehran. 2009.
- [15] Sedaghat Ahmad, Khakpour Mozghan, Vahidi Taher: Relationship between the outdoor and indoor landscape of primary schools in order to promote the children learning (Through a viewpoint to the architecture of traditional schools of Iran). *Science Journal (CSJ)*, Vol. 36, No. 4, 656-670, 2015.
- [16] PRAVILNIK O BLIŽIM USLOVIMA ZA OSNIVANJE, POČETAK RADA I OBAVLJANJE DELATNOSTI PREDŠKOLSKE USTANOVE ("Sl. glasnik RS - Prosvetni glasnik", br. 1/2019, 16/2022 i 6/2023)
- [17] Krstić Hristina et. al: Interior-exterior connection in architectural design based on the incorporation of spatial in between layers. Study of four architectural projects. *Spatium*, Vol. 1, No.36, 84-91. 2016.

# THE WAY OF BEAUTY - ARCHITECTURE AS A QUASI-OBJECT BETWEEN CONSUMPTION AND SUSTAINABILITY

Milena Metalkova-Markova<sup>1</sup>

## Abstract

*This talk will address the current notion of beauty in architecture. According to modernist doctrines functionalism, explicit structure, efficiency and lack of ornament could create a modern sense of beauty to replace the old-fashioned concept in terms of aesthetic pleasure and sensual delight.*

*How can we define the concept of beauty in contemporary architecture and urban planning during 21st century? The talk will explore the expanding field of historic heritage preservation and its synergy with the ethos of sustainable architecture and biophilic design. Several examples from all over the world, connecting adaptive reuse of existing buildings with some inspiring aesthetic and moral notions for the present global environmental crisis are expected to outline the way of architectural beauty as a quasi-object between consumption and responsible environmental and community lifestyle.*

**Key words:** *beauty, adaptive reuse, sustainable preservation, quasi-object*

---

<sup>1</sup> Senior Lecturer Milena Metalkova-Markova, PhD, University of Portsmouth, Portsmouth, United Kingdom

## 1. INTRODUCTION

This talk is an attempt to address the notion of beauty in architecture within the current context of acute environmental crisis, global destruction of natural resources and the emerging possibilities of artificial intelligence within architecture.

More than 2000 years ago the Roman architect Vitruvius has defined three elements of well-designed buildings as *firmitas*, *utilitas* and *venustas*: structural stability, functionality and beauty. As translators from Latin have noted, the meaning of *venustas* relates to both aesthetic pleasure and sensual delight, which includes all the senses experiencing a work of architecture.

Asking AI about beauty in architecture now, the instant answer is that it is a subjective and multifaceted concept with seven elements that evoke a sense of pleasure, admiration and emotional response in individuals:

1. Proportion and Harmony, 2. Form and Shape, 3. Materials and Texture, 4. Light and Shadow, 5. Context and Cultural Relevance, 6. Functionality and User Experience, 7. Emotional and Symbolic Impact.

AI concludes that the perception of beauty in architecture can vary greatly among individuals and societies, as personal preferences, cultural backgrounds and historical contexts influence aesthetic judgments.

It seems that the lack of public debate and attempts to objectify beauty within the field of architecture are well justified to be avoided as subjective, non-quantifiable and not worthy taking into consideration, compared to more objective and useful categories such as sustainability, climate change, resource depletion, etc.

I will try to argue that the notion of beauty in architecture is always worth discussing and re-defining according to the spirit of time- *Zeitgeist*, spirit of place- *Genius Loci* and spirit of community- *Genius Societatis*.

It should receive its deserved place as a major consideration factor not only in architectural competitions, but in all decision-making processes of contemporary architecture and building practice. This means to face the reality that subjectivity always plays a key role in decision-making processes and completely objective decision is unachievable and unnecessary.

As stated by Zeki ( a professor of neuro-aesthetics-Ref.3) 'In our daily activity, we search and seek to satisfy that quality; in simpler terms, we seek the beautiful to nourish the emotional brain since, from a neurobiological point of view, all areas of the brain must be continually nourished in a way that corresponds to their specific functions.' He argues that beauty is not a luxury, but an essential ingredient in nourishing the emotional brain.

It is possible and necessary to talk about sense of beauty in architecture – one way to open this theme, avoiding a rigid, too simplified or a limited perspective is to talk about the way of beauty as a current of ideas, thoughts, emotional responses and sensibilities corresponding to our present time paradigms.

The way of beauty (similar to the Way of Tea to describe Japanese tea ceremony) is a process of observing, noticing, talking, sharing and declaring significant aspects, elements and expressions of beauty, evoking a sense of pleasure, admiration and emotional response in individuals.

In order to describe some aspects of current sense of beauty, it is necessary to mention the radical change modernism in architecture implemented in architectural theory and practice of 20th century in terms of a 'new' sense of beauty.

According to modernist doctrines functionalism, explicit structure, efficiency and lack of ornament could create a modern sense of beauty to replace the old-fashioned concept in terms of orders, ornament, aesthetic pleasure and sensual delight. Oscillating between abstract modular orthogonality and organic plastic curvilinearity, architecture debate in modernism selected utilitarian box-like repetitive design approach in a large part of the 20th century.

This 'tyranny of the right angle' has brought destructive long-lasting consequences of uniform, uninspiring buildings and cities all over the globe. A reverse bacchanalia of curvi-linear complex shapes has flourished since late 20th century and architects such as Frank Gehry, Zaha Hadid and Santiago Calatrava have freed our cityscapes, building perceptions, public buildings and housing.

Nowadays architecture enjoys a luxury of freedom in terms of choice of architectural style- historic buildings coexist with neo-historicist eclecticism and the combinations of forms, shapes, materials seem infinite. Sustainability principles seem to influence more and more a 'u-turn' toward orthogonal, compact, minimal exterior surface, locally sourced materials and vernacular traditions.

A deeper synergy between preservation and architecture seem to show the way of the beauty. Almost ten years ago Rem Koolhaas stated that preservation is architecture last saving retreat (Ref.2) and it is overtaking us. Multiple adaptive reuse projects seem to offer a clue to connect heritage, sustainability and architecture.

During economic boom periods humans tend to overbuild and large part of our planet is already a built-up jungle – instead of continuing to destroy arable land and nature habitats, it is our responsibility to deal with the built-up environment and adapt it to help us cope with global warming, sea rise and population inequalities.

Some Japanese and European architects have found ways to re-design concrete skeleton buildings from 1960's to fit our present energy efficiency, flexibility of use and aesthetic sensibilities. Adaptive reuse is beautiful in its ethos and the possibility to create a meaningful dialogue between historic architecture and contemporary sensibility.

What can we say about beauty in architecture nowadays? I would like to look at a few contemporary projects and some themes defined by Juhani Pallasmaa for an inspiration.

## **2. THE WAY OF BEAUTY- SIX THEMES AND SIX PROJECTS**

For the 21<sup>st</sup> century I will borrow six terms from Juhani Pallasmaa who stated them as important for architects: slowness, plasticity, sensuousness, authenticity, idealization and silence. I will try to define beauty in architecture, observing six architectural projects, I have experienced and relating their qualities to the aesthetic notions of Pallasmaa.

### **2.1. Slowness- City of Culture-MUDEC- Milan (David Chipperfield)**

*There is a tacit wisdom of architecture that has accumulated in history and tradition. This is a wisdom that luminously reveals the mental essence of the art of architecture. But architecture needs slowness to re-connect itself with this source of silent knowledge. Architecture requires slowness in order to develop again a*

*cumulative knowledge, to accumulate a sense of continuity and to become enrooted in culture.* Juhani Pallasmaa

Chipperfield creates a careful sequence of spatial layers around a high luminous core volume of glass in an organic shape as an approach toward spatial depth. Visitors are slowly experiencing the revelation of a 'sacred' interior space, carved within the historic structures at the periphery.

Slow architecture is a movement parallel to slow food movement in Italy.

## **2.2. Plasticity- St Pancras Station, London (John Mc Aslan and Partners)**

*Architecture has become an art of the printed image fixed by the hurried eye of the camera. As buildings lose their plasticity and their connection with the language of the body, they become isolated in the distant and cool realm of vision. The dominant role of the photographed image in today's architectural culture as well as new graphic means of generating architectural images have contributed to the flatness and retinality of architecture.* Juhani Pallasmaa

The architects connect, embrace and shelter the space between two significant historic buildings in London by means of creating a delicate plant-like metal supporting structure. It is an example of a biophilic design in terms of interpretation of natural forms' plasticity for shelter. The contrast between historic orthogonal dark brick buildings with the white organic permeable and continuous texture is very powerful.

## **2.3. Sensuousness- Caixa Forum- Madrid (Herzog&De Meuron)**

*The architecture of us architects is certainly sterile and schematic in comparison to the poet's sensibility. The spectrum of emotions conveyed by today's architecture is confined to the narrow range of the visual aesthetic experience, and it lacks melancholic and tragic as well as ecstatic polarities.* Juhani Pallasmaa

This building is defined by Charles Jencks as the best post-modern collage. Its beauty lies in the multi-sensory experience of the visitor. The smell of the green wall plants, the sound of the running water, the warm touch of the brick and the cold coolness of the metallic surfaces seem to calm the contemporary nomads, stretched between the high tech and the heavy load of history in the middle of a metropolis.

Ecstatic polarities can be experienced between the urban chic, the working industrial feel and the nature under arrest.

## **2.4. Authenticity- Museum MACRO- Rome (Odille Decq, B. Cornette)**

- *Authenticity is frequently identified with the ideas of artistic autonomy and originality. But I understand authenticity more as the quality of deep rootedness in the stratifications of culture.* Juhani Pallasmaa

The architect plays with the power of reflection at a series of layers- rain water on the pavement, rain water on the roof, glass partitions and semi-transparency to connect existing and new spaces.

The whole project is a living creature with a burning heart of red auditorium, buried in the middle of the space and traversed around and through. The care in the design of toilets with living associations is worth mentioning too.

## **2.5. Idealization- La Samaritaine store reconstruction - Paris (SANAA)**

*The architect's responsibility is to penetrate the surface of commercially, socially and momentarily conditioned desire.*

*The authentic artist and architect must engage in an ideal world; architecture makes concrete an ideal view of life. And architecture is lost at the point that this vision and aspiration for an ideal is abandoned.* Juhani Pallasmaa

Japanese duo of Kazuyo Sejima and Ryue Nishizawa seems to offer an interesting concept of the shopping as a retail therapy and immersive experience. The undulating glass wall reveals excitingly, while is hiding -an art approach well known from the ancient Greek statues.

## **2.6. Silence- Fondazione Prada- Milan (Rem Koolhaas)**

*A powerful architectural experience eliminates noise and turns my consciousness to myself; I only hear my own heartbeat. The innate silence of an experience of architecture results, it seems, from the fact that it turns our attention to our own existence -- I find myself listening to my own being.* Juhani Pallasmaa

Koolhaas is using mirror surfaces on elevations as a way to recollect certain Italian Renaissance urban planning principles. He is creating a series of historic fragments as a simulation of time and various associations/allusions – the Golden painted building evokes the Golden pavilion in Kyoto, while large empty gravel spaces evoke the silence of the Zen Buddhist rock garden.

## **3. ARCHITECTURE AS QUASI-OBJECT BETWEEN CONSUMPTION AND SUSTAINABILITY**

It is easy to exaggerate the power of architecture while keeping the debate in a tight professional audience. Anthropologists define architecture as applied anthropology where our built environment bears the imprints of working patterns, gender relationship, cosmology, ritual&beliefs and social hierarchy.

As an 'impure' field between art and science architecture cannot directly create a big shift in society as this lesson we have learned from the noble utopian attempt of modernism in 20th century. Human beings and behavior have been shaped by other factors for millenniums and perception and inhabitation of spaces do contain ancient deeply encoded patterns, which architects need to address for architecture to be perceived as beautiful.

On the other hand, architecture is a quasi-object in the meaning of Bruno Latour- it can channel/ foster/ enable or prevent human communication and stimulate or calm down the senses. We tend not to notice the shelter when we feel tired, escape from cold, rain or sun. However, the quality of the shelter in its siting, orientation, window openings, materials, decoration, etc. can make us emotionally satisfied or depressed. Beauty in architecture is the emotional shelter we can find in space and it is rarely defined by the architectural style, orthogonality or curvilinearity.

It is the quality of the frame (architecture) to connect humans with nature, climate, other humans and non-humans which can enable us to strike own balance between consumption and sustainable lifestyle.

It is not by chance that vernacular architecture has been a strong inspiration for many orthodox modernist architects such as Le Corbusier and he sketched several

vernacular houses in Bulgaria and other Balkan countries during his travel by horse at the early 20<sup>th</sup> century.

Its timeless beauty (fig.5) can be found in the relationship to site, climate, hand made materials, possibilities for human/non-human communication and mediated contact with nature. *Architecture without architects* (Bernard Rudofski) is inspiring for many contemporary architects, extracting and interpreting its features as a quasi-object or interface between humans and nature. It has both the anthropomorphic features of a spatial skin for humans (keeping thermal comfort, proper humidity and ventilation) and it belongs to nature with its materials withstanding rain, snow and wind. Contemporary architecture behaves in a humble way toward nature, shifting gradually the nature' dominance narrative of the Europocentric building concept, which is so typical for the industrialization spread at the end of 19<sup>th</sup> century.

Kengo Kuma' Kitakami canal museum demonstrates architect's humble attitude to nature, blurring the boundaries between building and landscape. It is a relevant approach in the age of environmental catastrophe, caused by human large scale transformation of landscape. Hopefully our deeply ingrained sense of beauty for the built environment as a harmonious synergy with natural restoration processes, will make a 'u-turn' toward remembering a building culture, able to prevent the extinction of our species from the planet.

AI soon will be able to create tangible manifestations of vernacular settlements and buildings. What is beyond AI possibilities is the intangible sensibilities which make architecture a 'living' creature- extension of our bodies and senses. In his novel 'Time shelter' Georgi Gospodinov speculates about each nation asked to select a particular time period from history to revive and live in most comfortably at present.

In 21<sup>st</sup> century all historic periods are available as shelters – what kind of architecture can offer a shelter for the soul as simple as a hut and as elaborate as a 'painterly surface'? Architecture as a quasi-object between the observer and his/her own imagination and cultural referential frame might be worth considering.



Figure 1. 2023 City of Culture, Milan (photo by the author)



*Figure 2. MUDEC by David Chipperfield, Milan (photo by the author)*



*Figure 3. Inside MUDEC by David Chipperfield, Milan (photo by the author)*





*Figure 4. The beauty of public space, Prague (photo by the author)*



*Figure 5. The beauty of vernacular, Chuprene, Bulgaria (photo by the author)*

#### 4. REFERENCES

- [1] McCarter Robert, Pallasmaa, Juhani.: **Understanding Architecture**. *Phaidon Press*, 2012.
- [2] Koolhaas Rem, Otero-Pailos Jorge: **Preservation is overtaking us**. *Columbia Books on Architecture and the City*, 2014.
- [3] Zeki Semir: **Beauty in Architecture No, not a luxury; only a necessity**. *Architectural Design, Vol.89, issue 5, Special Issue:Beauty Matters: Human Judgement and the Pursuit of New Beauties in Post-Digital Architecture*, 2019.

# **AFFIRMING THE CONCEPT OF CONTINUITY IN THE MODERNIST HERITAGE THROUGH THE NOTION OF BORDER: CASE STUDY OF THE MEANDER BUILDINGS IN NEW BELGRADE'S BLOCK 23**

**Vanja Spasenović<sup>1</sup>, Bojana Sićović<sup>2</sup>**

## **Abstract**

*City planning is shaped by urban, political, social, and other resolutions that are materialized in the spatial plan. As an example of post-war architecture of the 20th century, New Belgrade was developed on modernist principles focused on the essence of dwelling, along with the idea of continuity based on the formation of fluid, liminal spaces and designing "from the inside out". Taking into account that the blocks of New Belgrade are particularly valued in the modern-day as locationally desirable and spatially high-quality living units, the research motive is the observed change in the way that one block entity is considered in today's context against the system of ideas embedded in the object's design concept. In accordance with the aforementioned, the research premise is that the long-term recognition of the overall quality of New Belgrade residential blocks can be reflected in the preservation of human-scale continuity, which therefore also ensures temporal continuity - the sustainability of project over time. The proposed hypothesis will be researched through the analysis of continuity and observed in the form of ideology instilled in the spatial organization, relying on the user as a reference value. The continuity of the observed spatial zones is confined by their liminal condition. Therefore, the border significance is determined through spatially defined phenomena of different nature (physical, immaterial, social). The methods used in this paper are theoretical overview, case study, and graphic analysis of the meander objects and their wider spatial context in New Belgrade's block 23. Graphic analysis, namely mapping of relevant borders, sets the frameworks of spatial zones that participate in the construction of place continuity. Research result is the establishment of a concrete relationship between the concepts of spatial continuity in modernism, illustrated through the phenomenon of the border, which further influences the quality of living in the building after its construction. The research significance lies in a comprehensive understanding of the relationship between theory and practice, that is, in understanding the process of design and life of the chosen study objects, observing their development from the initial idea, through project realization, until its present-day existence.*

**Key words:** *Border condition, Mapping, Space analysis, Urban planning, Identity*

---

<sup>1</sup> Teaching Assistant, Department of Architecture, Faculty of Architecture, University of Belgrade

<sup>2</sup> Associate, Department of Fine and Applied Arts, Academy of Arts, University of Novi Sad

## 1. INTRODUCTION

Modernist architecture was based on user-dependent ideology as its basic constitutive motive, according to which we define space and provide answers to the current socio-historical tendencies. This paper primarily discusses the topic of housing as an essential existential need in the post-war period, where the reflection of space is viewed through (a) horizontal plans, (b) the development of typology patterns for the improvement of use values, (c) "inside-out" design principle, (d) connecting spatial units while propagating the continuity of space, and (e) overcoming boundary determinants. The urban development of New Belgrade does not only overcome some of the natural limits in the spatial growth of the city, but it also expands on new conceptual block units that are created in favor of the aforementioned habitological values. In the formulation of the Central Zone made up of nine sections, Block 23 is structurally planned against its corner oppositions and morphologically developed in relation to Block 21 as its predecessor. During the development process, the aim was to weaken the rigid compositional relationships, open up the internal free space, and create smaller units within large object formations. Viewed as a continuous structure and a connecting element at the block level, the meander is fragmented and enriched with boundary spaces that, despite appearing discontinuous, additionally strengthen the relationships within the entire structure. By classifying border conditions and their characteristics, the paper strives to understand the initial design concept of the meander buildings in New Belgrade's Block 23, as well as a theoretical framework in relation to practical building aspects fifty years later. An important point for this analysis is the overall tendency of late modernity for the "blurring of boundaries" as a way to soften rigid standardized determinants and create transition zones made up of overlapping functions and programs [1]. The research hypothesis is that modernism and the "Belgrade school of housing" provided not only the modalities for creating spatial continuity through shaping existing spaces, but also a time-sustainable response to transformative needs. The modern movement is the only true tradition of the present because it implies that historical continuity does not include borrowed motives and ideals, but human values that must be conquered in new ways [2].

The research goal is to affirm the border as a building element of user-driven continuity through simultaneous analysis of the set hypothesis in theory and practice. In the first part of the paper, the theoretical framework of the border phenomenon in architecture is defined, viewed as a basic building element of continuity. The following research segment interprets knowledge from relevant literature and is later verified through a case study in the physical context of the meander building in New Belgrade's Block 23. The technique of graphic analysis used in this research is mapping, due to its ability to present and analyze different elements and conditions in one defined spatial framework. Concluding remarks include a discussion of theoretical and practical results. The result of the theoretical analysis is the formation of unified categorization of boundaries in architectural research, based on knowledge from scientific sources of relevant disciplines, while practical results include the use of mapping as a tool for detecting, illustrating and interpreting recognized boundary elements, and conditions that build continuity.

## **2. BOUNDARIES AS BINDING ELEMENTS OF CONTINUITY**

### **2.1. The phenomenon of borders in architecture**

A man tends to live within closed and limited space [3], which is a reflection of the anthropological search for shelter and security. Boundaries form the division of inside and outside, or rather being within or beyond the boundary frames, which becomes one of the primary architectural procedures and "the primordial act of architecture" according to Wolfgang Zucker [4]. The closing and dividing features of the border are determined by intermissions or openings that reflect continuity and/or discontinuity, a certain direction and rhythm of the architectural structure [5]. On the other hand, Martin Heidegger states that the border is not only a division line that determines boundary presence, but that it is also a place where something else begins its existence [5]. Therefore, borders can also be defined as places where two or more entities can meet. In these circumstances, the border is no longer a separating element or partition, but a spatial field within which the paths of encounter are located and framed. With the daily use of space in these encounter zones, the idea of a border as a solid dividing line is lost [6], and therefore borders become synthesizing elements, important for ensuring continuity within a spatial entity.

#### **2.1.1. Border characteristics and forms of its objectivity**

A conflicting interpretation of boundary features can be found in the research of Piero Zanini. Through discussing the meaning of the border as an above all dual phenomenon that "connects through separation" and "unites the unrelated" [3], Zanini highlights several complex forms of appearance, of which only the selected ones are relevant for this research. These are: (a) the boundary as a border [3], which arises with the need to define differences and limitations and has a divisive character, (b) the boundary as a transition zone [3], occurring as an intermediate space of different entities and has a synthetic character, (c) the boundary as a third element [3], which most often arises from the previous category as the border becomes an entity in itself, and (d) a portable boundary [3], which surfaces as temporary, weak and extremely transformable.

Additionally, when analyzing the importance of spatial experience complexity, Schoonderbeek defines four marginal states that are formed when two zones of different spatial, programmatic, functional, ambient, and other specific characteristics come into contact. They are the following: (a) Boundary as differentiation [7], characterized by spatial elements that initiate or maintain segregation, and define wholes as unique and separate entities; (b) Boundary as performance [7] that actively affects its "hindsight", that is, it is perceived as a performative zone within which several boundary conditions can occur; (c) Border as an encounter [7], which implies a border state of exchange within which the touching spatial zones are not mutually exclusive, but they mix, strengthen, highlight, and reduce other border activities; and (d) Simultaneous boundary [7], which implies that the opposite side is not a space of radical difference, but another place that can potentially condition certain similarities and simultaneously incorporates spatial as well as temporal differences and similarities.

By reviewing the theoretical knowledge on the interpretation of borders and border conditions in architectural and urban research, it can be concluded that the border is known as an extremely layered and complex phenomenon. The limited observation of the border through its ability to divide and separate, denies the existence of other boundary conditions that build spatial continuity. It can be concluded that for the evaluation and analysis of boundary conditions in architectural theory and practice, it is necessary to look at the phenomenon of the boundary as a whole, with all its potential modalities and phenomena. After reviewing the literature through the methods of critical analysis, selection, and systematization, we formed a new categorization of border typologies, their characteristics, and significance, based on previously presented scientific sources (Table 1).

*Table 1. Border typology, characteristics and significance*

<b>Border typology</b>	<b>Border characteristics</b>	<b>Border significance</b>
ESSENTIAL BORDER	stable and material, guides, suffers the least changes and deformations, contributes the most to the visual recognition of the object	enables physical continuity and the development of new boundary forms
COLLECTIVE BORDER	meeting and negotiation zone; creates communication centers and extensions; it networks and enables the establishment of utilitarian connections	enables communication and utilization of continuity
PRODUCTION BORDER	simultaneous, creates new zones, prone to manipulation, a reflection of personal affinities, more apparent in the interior than in the public space (due to personal control)	enables user-driven continuity
PORTABLE BORDER	light, changeable, mobile, weakest and least stable	enables permeability control

The objects of the meandering typology build a wide range of border conditions, and are imposed as suitable spatial components in the reading of previously presented theoretical viewpoints. They are also elements of continuity, clear physical structures that bind context components into a traveling and unified whole. However, they also represent a certain physical discontinuity in their interruptions and changes in the direction of extension, elements that layer the solid structure of the object and build a large number of micro-units within a unique formation. As objects of great length, they not only simultaneously separate or join the physical components of their environment, but they themselves, within the framework of their dimensional determinations, also become a multi-layered boundary element.

## **2.2. Mapping as a tool for spatial boundary analysis**

Despite the fact that spatial analysis is an established practice in architectural research, boundary conditions and their characteristics are rarely research subjects. The multi-layered character of specific border spaces is almost never analyzed and discussed within the contemporary architectural discourse. When

we talk about the experience of space from a human perspective, the perceived environment is bounded by limits that establish it as a whole entity [8]. Heidegger argues that space can only come into being when the location allows it to appear: "space, something that is cleared and free, comes into being within the boundary" [5]. Marc Shoonderbeek points out that, if we consider borders as marginal urban zones in which new conditions develop, it is necessary to provide adequate types of space readings, such as mapping, with the aim of forming alternative models to illustrate spatial, social, and temporal conditions in the analyzed liminal space. The research on the continuity of the human dimension deepens the interrelationships between the physical elements of space and their boundaries through the social component. Taking into account the claim that mapping is considered a tool for "illustrating a social construct in a spatial framework" [9], it can be concluded that it is an adequate instrument for research within the framework of this paper because it allows the different modalities of analysis to be interpreted within a single graphic language. The instrumentalization of mapping in the architectural discourse implies the translation of a place, concept, state, process, or event into a spatial plan. Mapping as a tool for a better understanding of the environment does not interpret space exclusively as a set of elements, but as a unique system of visual language with a clear spatial logic. Visual representations have the potential to convey a great deal of information to the researcher that often exceeds the scope of verbal data exchange. The use of maps in architectural research enables the equal evaluation of all the relevant aspects of spatial analysis, such as place, program, volumetry, or materiality [9].

The process of boundary mapping illustrates the relationship between the reality of an architectural object and the complex system of messages, ideas, and influences embedded during the analytical phase of the design process. The mentioned relationship between the object and concept (in this case, the meander and the idea of modernism in residential architecture) will be expressed through defining the border as an architectural element that carries social, political, and cultural ideologies. The phenomenon of the border, interpreted through its previously recognized complex character, requires that in addition to the physical presence, specific atmospheric qualities of liminal zones are also carefully researched. Schoonderbeek recognizes the atmospheric qualities of borders in the objective arrangement of spatial entities – objects and light, temperature and material properties [7]. The previously defined potential of a map as a tool is particularly important for the graphic representation of borders because it includes the complex character and liminal spatial ambiguity of encounter, separation, performance, or simultaneity.

### **3. CASE STUDY OF THE MEANDER IN BLOCK 23**

#### **3.1. Central zone – Block 23 – meander buildings – apartment**

After the post-war depression, there was a need to increase the capacity of collective housing for about 40,000 inhabitants, which is why the construction of the third, most extensive phase in the development of the new Yugoslav capital on the left bank of the Sava was started [10][11]. As a result of a long-term planning process, aligned with the ideology of creating a modern and functional

city, the center of New Belgrade was conceived as a solid and stable core consisting of six residential blocks, grouped around three central blocks of city-wide public use [12]. In the plans for the Central Zone from the 1960s, the blocks were projected in relation to each other, like symmetrical fragments of a wider urban whole [12]. Thus, Block 23 is coordinated with the compositional features of other corner blocks of the Central Zone (21, 28, 30), morphologically defined by towers, as corner benchmarks, objects, as reinforcing elements placed along the peripheral boulevards, and meanders as a connecting element at the block level. However, the plan practically only served as a "schematic indication of compositional relationships and the grouping of high and low buildings" [13], and was never completely implemented. Socio-historical changes were the main focus in block realization, but the concept did not neglect experientially observed opportunities for improvement by listening to technological innovations, market needs, and qualitative values of space.

The meanders as the lowest building elements with prominent spatial continuity in terms of their length had the task of connecting the tall peripheral objects into a unique block formation [13]. Positioned inside the block complex, imbued with greenery and pedestrian communications, it was supposed to create new micro-ambiances in the form of internal courtyards and to enhance the dynamics of otherwise monotonous space. During the building of Block 23 (1969–76), the meander retained its morphological task, but its initial volume changed due to the experiences with the previously built block of the Central Zone – Block 21. Its unique structure, which is almost one kilometer long and split into two segments, results in two objects compositionally defined as a mirror reflection with the central break. The increase in tract depth and definition of atriums as internal gaps are accompanied by the fragmentation of the volume into smaller horseshoe-shaped structures, as well as overhangs in the form of bay windows, "caesuras" (stair overhangs), balconies-loggias, etc. [11]. As a result of all the abovementioned, the meanders are constituted by two lamellae joined in the typology of two tracts. The breakdown of the meander facilities was largely influenced by the need to increase the square footage of the apartments, while fostering the continuity and flexibility of space, as well as the possibility of expansion in accordance with the variation in the number of household members. The transformation of the building concept caused by the reflection on the validity of the apartment as a basic building element, reflects the principle of designing "from the inside out", but also the evolutionary implementation of the "Belgrade apartment concept" during the late modern era, which nurtured the abovementioned qualities. This primarily referred to the flexibility of the apartment, which would ensure time continuity in terms of purposeful duration and adaptation to new users and the demands of time [14].

### **3.2. Mapping of the collected data**

The cartographic process itself consists of four steps: (1) data collection, (2) cartographic abstraction, (3) map reading and analysis, and (4) map interpretation [15]. In this specific case study, the graphic apparatus of mapping included all the mentioned cartographic phases. Data collection aimed at understanding space volumetrics and the information previously obtained from literature, while graphic plans and the resulting photo documentation were first translated into axonometric



diagrams (Fig. 1). In the second phase, the narrative diagrammatic input was reduced to abstract drawings with accompanying legends that were further analyzed and interpreted at several different scales, from the level of one residential unit as a building element (Fig. 2) to the level of a block (Fig. 3). The drawings show the directions of border blurring, their overlapping, synthetic effect, and they also illustrate that more stable borders support those that have unstable character, at least in a physical sense.

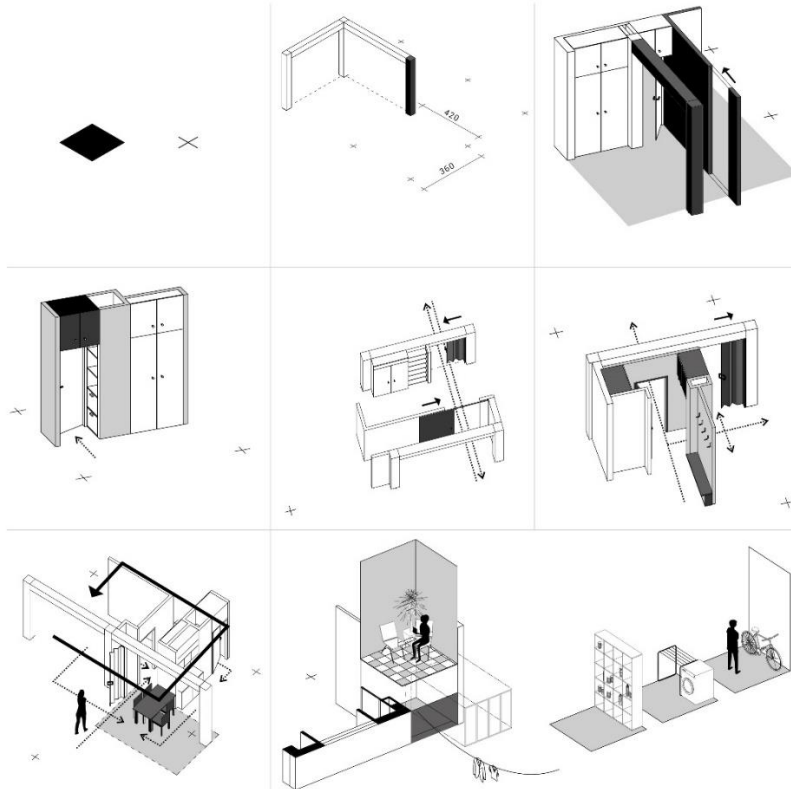


Figure 1. Diagram of data collection

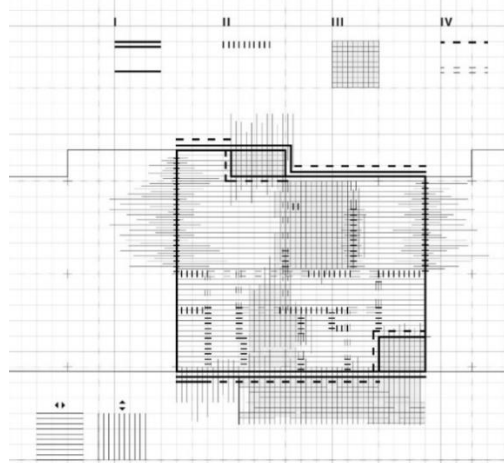


Figure 2. Apartment level mapping

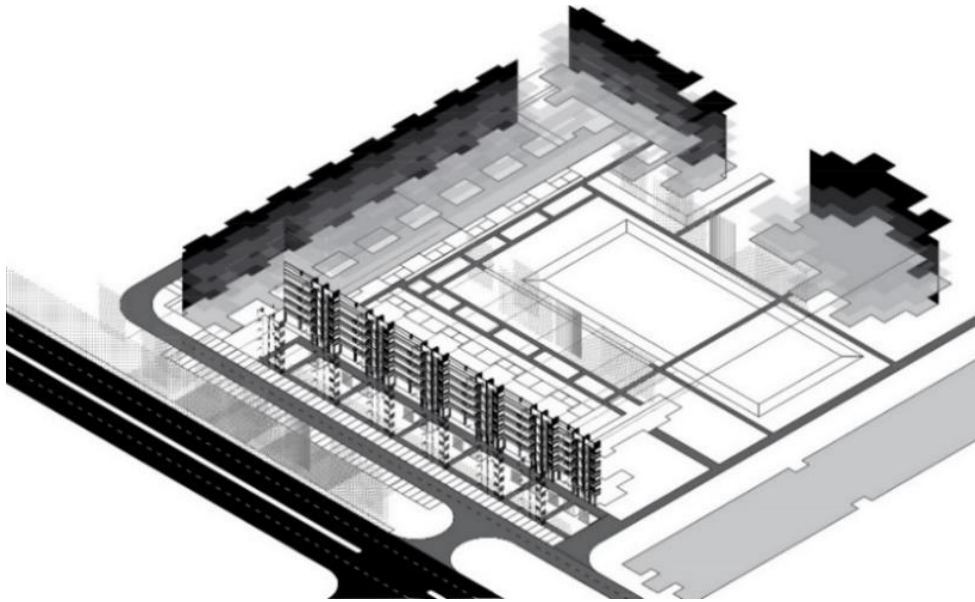


Figure 3. Block level mapping

## 4. RESULTS OF GRAPHIC ANALYSIS

### 4.1. Elements of the essential border

*External facade wall:* The street facade stands out as a perceptually important essential boundary. Its dominant participation in the perception and recognition of the spatial unit from the street, as well as the contact with residential units from its opposite side, causes the fixed border element to dissipate and stratify due to its importance, forming within itself more border phenomena of another categorization (e.g. windows, loggias, flower pots, air conditioning units – striving for personalization of the public area); in this way, the facade as a border is additionally layered.

*Street:* The main road that connects block 23 with the rest of New Belgrade, the city center, as well as the highway, is the street Antifašističke borbe. During the 1960s, Kevin Lynch emphasized the importance of perceiving paths (streets) as an important element of building place identity. He claimed that the specific character of the street facade gives a clear identity to the street itself, and, additionally, that paths leading to recognizable landscapes and important strategic points become crucial for defining place identity [16].

*The kindergarten:* The kindergarten within the block does not form a pronounced physical boundary like the previously mentioned examples, but in mutual relation with the meander, it builds an essential boundary, which is recognized in the perceptual continuity achieved together with the meander object. Without the kindergarten, the meander would not be compositionally complete; the existence of an additional free-standing building at the top of the imaginary square formed together with the meander enables the definition of a perceptible essential boundary, which further produces new boundary conditions in the zone it surrounds.

## 4.2. Elements of the collective border

*Secondary streets and pedestrian communications:* The existence of clearly fixed boundaries allows additional marginal states to appear between them. Two dominant borders – the building facade and the street – form a series of access to vehicular and pedestrian communications, in order to enable the movement of space users. The meeting zones between access roads, designed parking areas, green barriers, and pedestrian access to the meander illustrate the collective character of these border areas. *Internal building walls (partition wall between two apartments):* By lining up the apartments with the support of a modular grid and standardized measures, the mentioned border element can horizontally and vertically translate, while maintaining the utility values of both apartments. Mate Baylon wrote that the partition walls offer the possibility of increasing the area of one apartment by addition of the room originally belonging to the neighboring unit, caused by the need to increase the standard of the unit itself, or by increasing the number of household members [17]. In the case of the analyzed building, two apartments also form a unique segment defined as a field between two vertical hubs (cores), which further affirms the collective value of this boundary typology. Translation of the mentioned border is partially possible with another neighboring apartment, so that two apartments sharing a common core can be seen as one grouping. *Interior apartment walls (partition walls within a residential unit):* As there was an effort to create open flowing spaces, the apartment interior is characterized by a fluid division, which is one of the essential changes with the advances of modernity [1]. Hollow walls enable the creation of circular connections, which achieves not only the continuity of communications as a feature of the collective boundary, but also the continuity of use while improving the flexibility of the entire apartment. *Vertical and horizontal communication of the object (core):* Like Heidegger's "bridge", this boundary element does not separate, but gathers and unites its environment into a single whole [5]. The core, as a carrier of vertical and horizontal communications, networks spatial elements into a unique structure of the object; with a constant circulation of users, it also becomes a meeting place.

## 4.3. Elements of the production border

*Commercial zone in meander ground floor:* The existence of a large number of communication boundary conditions on the ground floor of the building (access roads, pedestrian paths, and their intertwining) creates the need for additional function in public areas of residence and retention. The need for a new boundary condition in this case arises from a large number of encounters that collectively create new boundary typology. *Terrain dynamics:* The zone of the inner yard is bounded by the previously mentioned essential boundary, which is formed by the meander and the kindergarten. This perceptual essential border creates new liminal states, which are also characterized through perceptual potential. In this case, the dynamic is produced due to the monotony of the existing terrain, which allows for the introduction of additional dynamics in order to adequately refine the perceptual impression and prevent perceptual fatigue. *Inner courtyard – atrium:* The atrium can be read in two ways because it is at the same time an open space inside the building and an integral part of the two-track building

typology. Therefore, the atrium leads to blurring of the boundaries both in the inside-outside relationship and in terms of use, networking the private and semi-private components. As a production boundary, it creates new socio-spatial qualities among the tenants of one building segment with the shared use of the premises adapted to personal and collective needs (such as storage areas, laundry room, etc.). *Loggia (balcony-loggia)*: As one of the constitutive motifs of the "Belgrade apartment", the loggia reconsiders the boundary between inside and outside. It enables moving of the apartment border, the simultaneous presence of closed and open space (with the application of an adequate portable border) and the production of new spatial phenomena. *Dining room on the extended communication*: This border typology creates a unique overlapping area by combining the economic, living, and communication zones. Immediate space does not only erase the border frames of its permanence in physical and functional terms, since it has no clear spatial determinants and purpose, but it also imposes itself as a boundary element by producing simultaneous flows in the apartment. In fact, the dining room with extended communication allows uninterrupted use of the living room intended for younger users, while it itself becomes a secondary center for the gathering of older members of the household (regulates the generational division). *Transient living room*: Manipulates the border between the quiet and noisy part of the apartment. It can also be said that it regulates the "wrong programming of the living room space", where the sleeping bed was planned [17]. Formed on the overlap of the day and night zones, this half-room or room per square meter becomes a multi-purpose room that can reflect the personal affinities and needs of the user himself, even in the modern-day. In terms of use, the transient living room can be an additional bedroom, an extension of the living room, a study, a wardrobe in the adjacent room, and similar.

#### 4.4. Portable border elements

*Doors and windows*: In his book *Human Space*, Otto Friedrich Bollnow points out the statements of Georg Simmel "that doors set a limit for themselves, but with freedom... in such way that they can remove that limit again" [18]. With technological development and the application of Le Corbusier's principles, along with their semi-permeable character, openings become an important implicative motif and a reflection of the weakening of boundaries in modernist architecture [19]. They allow places to be elongated outwards, but also for the exterior to penetrate over the interior, forming a transition zone. Therefore, the doors are numerous, mostly sliding, folding or in the form of a passage, and the windows are in a continuous row, with an emphasized horizontal character, thereby enhancing the visual connection with the environment. Today, with the replacement of dilapidated woodwork, as a semi-permeable portable border, the doors and windows in the external environment reflect the changes in the internal organization and division of the apartments. *Furniture*: Furniture takes on the function of a portable boundary element, whether it participates in the formation of zones or performs movable partitioning of a single space, instead of or in conjunction with partition walls. For the object in question and the period of construction in the sixties and seventies, "furniture composability" is an important standardization and adaptability feature [17]. As an element of equipment,

furniture is particularly important in auxiliary rooms and communication zones such as corridors, passages, storage rooms, etc., which are significant from the point of view of each user.

## 5. DISCUSSION

From both theoretical and practical standpoint, we are witnessing a gap between what New Belgrade should have been from an ideological aspect, what it was at the time of its creation as a 'big dormitory', to what New Belgrade is today – one of the most desirable city areas [12]. In the case of Block 23 and the meander building, the economic constraints also gave birth to some of the spatial characteristics, such as the upper limit of apartment size found in two-and-a-half-room or three-room apartments. On the other hand, with the careful design of the boundary space determinants, it is possible to change the mentioned 'human measure', and thus allow further modification of the mentioned dwelling units in the present. This primarily refers to the possibility of moving the dividing walls, but also to the flexibility offered by internal communication boundaries, such as light partition walls and portable borders of openings and equipment elements. It has been shown that, at the apartment level, the multiplication and development of border elements depend on the essential border as fixed and stable. Thus, the apparently weighted limit that determines the frame of one habitological component becomes the binding – connecting border of two apartments, while on the other axis it provides support for portable and creates production boundaries. Consequently, they enable temporal sustainability and the production of new spatial qualities according to personal and collective tendencies. Research contribution is the recognition of production border spaces as one of the greatest generators of human-scale continuity of modernist architecture. At the block level, there is a smaller scope for personalization of the analyzed spatial coverage, which is partly due to the collective character of the open public space. This claim can also be questioned through the concept of scale, because graphic analysis allows us to see the degree of boundary blurring in the interior and exterior space. Micro-environments in private residential zones have a greater manipulative range, which also leads to the complexity of border conditions, while in public zones it is more difficult to achieve layering in border areas. Graphic analysis at the block level represents a quality method for the research of continuity expressed through borders, because it allows us to see the cause-and-effect relationship between different typologies of borders. The research outcome defines the conditioning character of essential boundaries. The character of essential boundaries, which can be physical, perceptual, social, immaterial, or other phenomena, further determines the character of communication, production, and portable boundaries that arise within the originally located essential boundaries. Taking into account the previous statement, it can be concluded that the complex phenomenon of the border does not define the user-driven continuity exclusively by only its existence, but also through the uniqueness, value, and characteristics it carries.

## REFERENCES

- [1] Кордић Милена: **Међупростор**. *Задужбина Андрејевић*, Београд, 2012.
- [2] Noberg-Schultz Christian: **Svrhe u arhitekturi**. *Arhitektura kao gest, Univerzitet u Beogradu, Arhitektonski fakultet*, 81–82, 2012.
- [3] Zanini Pjero, Slatinac Slavica, Hamović Zoran: **Značenja granice: prirodna, istorijska i duhovna određenja**. *Clio*, Beograd, 2002.
- [4] Arnhajm Rudolf: **Dinamika Arhitektonske forme**. *Univerzitet umetnosti u Beogradu*, Beograd, 1990.
- [5] Noberg-Schultz Christian: **Fenomen mesta**. *Teorija arhitekture i urbanizma, Arhitektonski fakultet Univerziteta u Beogradu*, Beograd, 260–273, 2009.
- [6] Schoonderbeek Marc: **Trans-mapping the Condition of the Border**. *Transilient Boundaries*, 115–120, 2009.
- [7] Schoonderbeek Marc, Havik Klaske: **Reading and reacting: from the research of border conditions to experimental methods in architectural and urban design**. *Nordlit 31*, 49–58, 2014.
- [8] Dolins Francine, Mitchell Robert: **Spatial cognition, spatial perception: mapping the self and space**. *Cambridge University Press*, 2010.
- [9] Schoonderbeek Marc: **Place-time discontinuities: Mapping in architectural discourse**. *TU Delft*, 2015.
- [10] Stošić Stojanka: **Detaljni urbanistički plan mesne zajednice Bloku 28 – Jedna faza razrade idejnog urbanističkog rešenja Centralne zone Novog Beograda**. *Arhitektura Urbanizam*, No. 41–42, 82–87, 1966.
- [11] Весковић Ивана, Јовановић Јелица: **Изградња блокова 21, 22, 23 Централне зоне Новог Београда и њихов значај у оквиру културног наслеђа Београда**. *Наслеђе*, бр. 19, 35–51, 2018.
- [12] Благојевић Љиљана: **Нови Београд: Оспорени модернизам**. *Завод за уџбенике, Архитектонски факултет Универзитета у Београду, Завод за заштиту споменика културе Београда*, Београд, 2005.
- [13] Ђорђевић Александар: **Urbanističko rešenje centralnog dela Novog Beograda**. *Arhitektura Urbanizam*, No. 2, 3–12, 1960.
- [14] Vujnović Ratko: **Prognoze i tendencije u stambenoj izgradnji u narednom desetogodišnjem periodu**. *Arhitektura Urbanizam*, No. 74–77, 9–10, 1975.
- [15] Muehrcke Phillip C., O. Muehrcke Juliana, Kimerling A. Jon: **Map use: reading**. *Analysis and Interpretation*, 1992.
- [16] Lynch Kevin: **The image of the city**. *MIT press*, 1960.
- [17] Baylon Mate: **Stanovanje: tema 1 Organizacija stana**. *Arhitektonski fakultet Univerziteta u Beogradu*, Beograd, 1979.
- [18] Bollnow Otto Friedrich: **Human Space**. *Hyphen Press*, London, 2011.
- [19] Noberg-Schultz Christian: **Egzistencija, prostor i arhitektura**. *Građevinska knjiga*, Beograd, 1975.

## COOPERATION BETWEEN ARCHITECTS AND STRUCTURAL ENGINEERS IN THE DESIGN OF COMPLEX STRUCTURES – THE REVIEW

Miloš Čokić<sup>1</sup>, Ružica Kovačević<sup>2</sup>, Radomir Folić<sup>3</sup>, Nadja Kurtović  
Folić<sup>4</sup>

### Abstract

*The relationship between architects and structural engineers went through a series of phases through history, following the technological advancement. This relationship is complex, but it is very important because it reflects directly on the mutual understanding of the idea and the possibility of realization of the project. Multidisciplinary design teams mutual understanding and cooperation are necessary in the process of building design and construction. The architects will gain better insight which will lead to more functional and efficient architectural design, if the collaboration between architect and structural engineers is present from an early start of the design process. Recent strong earthquake actions and their consequences indicate that there is the necessity to improve professional collaboration between architects and structural engineers. As the extreme result of lack of understanding and cooperation between architects and structural engineers, the results can lead to the lack of safety, integrity and functionality of the structure. Knowledge and mutual information exchange, especially in the early stages of the project are very beneficial and they lead to better results. The outcome of the successful collaboration between architects and structural engineers are design solutions that are more than just the structures that are built only to perform their basic functions. Most beautiful and inventive structures came as the result of a creative collaboration and mutual understanding between the architectural and structural engineers. This paper reviews the ways of collaboration between architects and structural engineers in the design of different complex structural systems.*

**Key words:** *mutual collaboration, complex structures, conceptual design, reliability versus esthetics, new technologies*

---

<sup>1</sup> PhD Civ. Eng., Structural Engineer, Termoenergo Inženjering, Bulevar kralja Aleksandra 298, Belgrade, Serbia, e-mail: [cokicmilos@gmail.com](mailto:cokicmilos@gmail.com)

<sup>2</sup> Grad. Arch. Eng., Architect, Termoenergo Inženjering, Bulevar kralja Aleksandra 298, Belgrade, Serbia, e-mail: [ruzica\\_qligic@yahoo.com](mailto:ruzica_qligic@yahoo.com)

<sup>3</sup> Professor Emeritus, PhD, University of Novi Sad, FTS, Department of Civil Engineering and Geodesy, 21000 Novi Sad, Trg Dositeja Obradovica 6, Serbia, e-mail: [folic@uns.ac.rs](mailto:folic@uns.ac.rs)

<sup>4</sup> Professor, PhD, University of Novi Sad, FTS, Department of Architecture and Urbanism, 21000 Novi Sad, Trg Dositeja Obradovica 6, Serbia, e-mail: [nfolic@gmail.com](mailto:nfolic@gmail.com)

## 1. INTRODUCTION

Throughout the history, people have been creating different structures with the ability of builders. The term – builders, means both, technical knowledge of construction engineers and architects formal and aesthetic sensibility. Most of the large, stone or brick made, highly aesthetic buildings were invented by such a person. When it came to a stark division between structural engineers and architects, in the mid 19<sup>th</sup> century, it was time when it was also open discussion on how to cooperate and who is more important for creating the life of the structure [1].

In Andrew Saint's book [2], the author researched the relationship between the architect and the engineer. He noticed and constructed his conclusion around three issues [3]:

- He [2] affirms that the two disciplines had no differences between one another from 1400 to 1750. During that period, the title of architect or engineer depended mainly on the type of the project, as well as on its associated hierarchy and institutions (king, military, church, etc.). This distinction, however, reflected neither different construction techniques nor different design capabilities.
- The professions' subsequent separation started in the time period from 1750 to 1900, as the reason of the continual demand for the new types of buildings and constructions during the 19<sup>th</sup> century. The emergence of new materials and a new scientific basis and methods for calculations, led to the emergence and use of different sets of skills.
- Reunification of the architectural and engineering professions happened during the 20<sup>th</sup> century, based on a need to unify the understanding between the professions (which lacked in the 19<sup>th</sup> century). In the 20<sup>th</sup> century, the engineer and the architect, worked together on the same projects, in a form of collaboration [3].

In the last two centuries, many aspects of the relationship between the two professions and their mutual influence on the design and creation of the structures, have always been the subject of debate [3].

The use of new materials, such as iron, steel, and reinforced concrete have each sparked revolutions with entirely new structures. Discovery of the principle of prestressing made possible prestressed concrete, high-strength bolted connections, and complex cable and membrane structures [3].

New materials, especially reinforced concrete, and their application gave a particular advantage to structural engineers at that moment, but soon after that, a period of searching for a modality of successful cooperation emerged. Since the architect is the person who solves the functional requirements through the project and visually shapes them, he, as a rule, expects the structural engineer to design the appropriate structures [1].

This second phase, Felix Candela, a famous Spanish-Mexican designer of bold and unusual concrete shells, witty depicts: "The second design phase...consists of a tremendous battle between the structural engineer and the architect...The result of the struggle is always the same: science prevails and the final design has generally lost the eventual charm and finesse of detail dreamed by the architect" [4].



After this description we could imagine how stressful and yet inspiring the cooperation between architect and engineer can be, and that projects become possible only through the cooperation of those two professions, despite the complex relationship. [5]

There are lot of examples which show that the relationship between architects and structural engineers is not always expressed in mutual appreciations. That this is rather a common opinion it can be concluded by reading Pfammater statement when he comes to touch upon another difference between professions: "For an engineer most design effort involves analysis. For architects design is the process of synthesis". [6]

If those start points are harnessed, the integration of those two opposing approaches is the aim of collaboration and the source of its value. Architects are considered the creative ones who always want to create masterpieces and push the boundaries of the physical feasible. In contrast to this, structural engineers are sometime seen as a person who behaves in a way that spoils others' pleasure, especially by not joining in an activity, who reduce the complex designs, because the design removes structural elements or is much too expansive. But apart from these impressions, the two professionals complement each other perfectly and they can rely on one another. Extraordinary structures of structural engineering have been created only thanks to their cooperation [7].

The effort put into productive collaboration between architects and engineers often passes unnoticed and intellectual recognition of their added value requires a kind of 'second sight.' Their projects show the balance between the possibilities of structural discovery on one hand, and assured handling of space on the other, resulting in the new culture of constructing between the two professions, based on impressive tenacity and skill to develop ideas together [3].

Since digital data processing entered the construction industry, the influence of new technologies has become perfectly obvious. In the last several decades, the whole process of calculations, construction, manufacturing, and installing is in a closed process chain with the aid of computers [3].

A great number of references is used in this text, which testifies that this is and had been a very important topic.

## **2. COLLABORATION – SEISMIC DESIGN**

As the principal designer of a building, the architect is responsible to make the crucial decisions about the structural design of their structures. Structural engineers are responsible to enable the idea of the architect into reality. It is crucial for architects and structural engineers to collaborate from the start of a project. Architects and structural engineers have very important roles in the design process. Architect, as the chief designer heavily depends on the contribution of the structural engineer in the selection of the structural system. Architects and structural engineers play a more critical role in regions of seismic hazard risk. Many seismic design regulations are focused on prevention of the loss of lives and major structural failures [8].

In an high-seismic activity countries, it is likely for a structure to experience a high consequence natural hazard over its lifetime. Observations made after the high-intensity earthquakes have demonstrated that the main factors which contribute to

structural damage of buildings are mostly the result of excessive floor accelerations and uneven distribution of inter-storey drifts. These seismic effects may not always be critical enough to cause damage on the structural system of a building nevertheless they can severely damage the nonstructural elements and contents of a building. It should be pointed out that repairing the nonstructural components and building contents comprise a large portion of the building's post-earthquake recovery cost [8].

### **3. COLLABORATION – REUSE AND PRESERVATION OF HISTORIC STRUCTURES**

Cultural diversity and architectural legacy of past and present cultures and civilizations required to be preserve and protected, for the pervious, current and future generations. In the process of preservation and reuse of existing historic structures, the existing materials and infrastructure are used. Historic buildings have many architectural and structural details in their design which respond to the requirements of the surrounding environment [8].

The example of old masonry monuments can be used to demonstrate how architects and structural engineers can collaborate in the reuse of historical buildings. From an architectural point of view, if the tendency is to restore and preserve old masonry buildings, it is almost inevitable to introduce architectural and structural modifications to the existing layout to accommodate the requirements of modern building techniques. However, the introduction of these elements can disturb the structural behavior of masonry buildings in an unpredictable and seismically unfavorable manner [8].

Since many historical monuments have complex form, it is quite difficult for architects, to predict the structural implications of their modifications on the structural system. In these cases, it is necessary to use structural engineers' knowledge and assistance in the whole process. Structural engineers use finite element method (FEM) for the structural analysis, through the use of adequate software packages. It takes into account the geometrical properties of the structure, joint restraints and the loading conditions and effects in the analytical model of the structure [8].

Results obtained through the FEM, using adequate softwares packages, makes it easier for the architects who are primarily visual learners to perceive the impact on the structural behaviour, as consequence of their design solution. Visual expression of mathematical analysis results, also enables easier communication process between the architects and structural engineers. It should be noted that in any country, in high-seismic area, any preservation work conducted on masonry buildings can not achieve the desired standards without a thorough analysis of the structural and seismic response of these structures [8].

### **4. IMPORTANCE OF COLLABORATION BETWEEN ARCHITECTS AND ENGINEERS**

Successful collaboration between architects and structural engineers bring much more to a project than just facilitating its design and completion. The client and the

users of a building are the primary beneficiaries of architect-engineer collaboration, but architects and engineers themselves benefit greatly [9].

Successful collaboration results in the following benefits which are illustrated by brief examples in Table 1 [9].

Table 1. Successful collaboration benefits, after [9]

<b>Benefits</b>	<b>Examples</b>
<b>Seismic performance</b>	<i>Optimal seismic performance is achieved through structural solutions which maintain architectural objectives but also make sure structural performance is uncompromised by configuration irregularities such as a soft-storeys or large torsional eccentricities.</i>
<b>Cost-effectiveness</b>	<i>A structurally-refined structural system allows an economic and cost-effective structural design.</i>
<b>Certainty</b>	<i>Reduction of re-work maintains the momentum of the design development progress.</i>
<b>Innovation</b>	<i>Improved design and construction systems and approaches challenges the understanding and embraces different points of view and push the boundaries in different fields.</i>
<b>Integration quality</b>	<i>Functional and aesthetic goals are better met when there is a meshing of structural layout with architectural planning requirements.</i>
<b>Satisfaction and professional development</b>	<i>Design team members widen their perspectives and approaches to design, learn and develop new skills whilst enjoying working together efficiently and harmoniously. They share ideas and solve problems together, so that the input of each profession overlaps.</i>

## 5. EXAMPLES OF COLLABORATION BETWEEN ARCHITECTS AND ENGINEERS – EXISTING STRUCTURES

Some examples of successful collaboration between architects and engineers are represented through the images and short description of the mentioned structures.

The first example (Figure 1.a) is the structure of United States Air Force (USAF) Academy Cadet Chapel. It is built in 1962 and it is located in Colorado Springs [10]. The principal designer and architect of the chapel was Walter A. Netsch Jr. of Skidmore, Owings and Merrill of Chicago. Construction was by Robert E. McKee, Inc., of Santa Fe, N.M. The Cadet Chapel is the most recognizable building at the USAF Academy and the most visited man-made tourist attraction in Colorado. It is an aluminum, glass, and steel structure with 17 spires, approximately 45m tall. It is

considered among the most beautiful examples of modern American academic architecture [11].



Figure 1. a) USAF Academy Cadet Chapel [10], b) Sanctuary of the Divine Mercy [12], c) Cathedral of Brasilia [10]

Sanctuary of the Divine Mercy in Kalisz (Figure 1.b) was designed in 1952 by Jerzy Kuźmienko and Andrzej Fajans, but its construction began in 1977. It is completed in 1993. There are no familiar simple and minimal lines and shapes, only brutal concrete and a patterned metal frame of windows [10].

Cathedral of Brasilia (Figure 1.c) is created using 16 concrete undulating columns forming a flower-like shape by Brazilian modernist architect Oscar Niemeyer and calculated by and calculated by Brazilian structural engineer Joaquim Cardozo in 1970. The windows filling space between the columns glisten in the sun reflecting the cathedral's white spires. However, they are stained with decorative patterns and drawings from the inside [10].

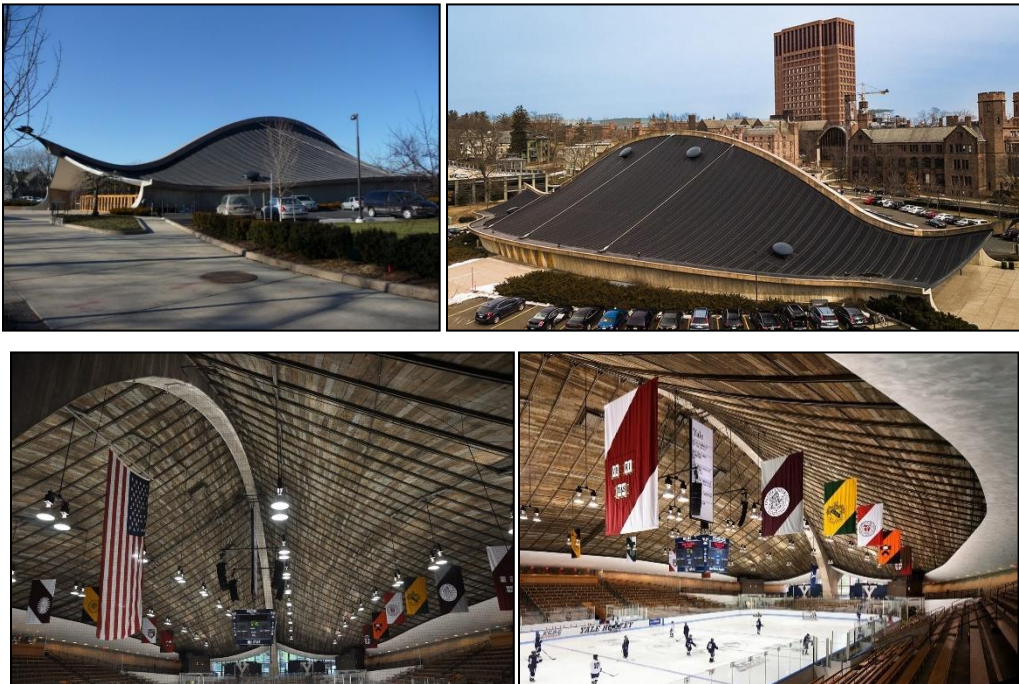


Figure 2. David S. Ingalls Skating Rink, after [10, a], [14, b,c,d]

Ingalls Skating Rink or Yale Whale (Figure 2), as it is also known, looks like a stingray with its curved roof and a cantilevering 'tail'. It is designed by a Yale graduate architect Eero Saarinen and Norwegian born, American structural engineer Fred Severud and built in 1958. This hockey rink is simple and complex at the same time,

in concept and execution [10]. The true beauty within the design found in its simplicity. It may look complex, even in its symmetry, but the main rink is simply a rectangular form with filleted edges. The hockey rink contains a span roughly 60m long by 25m wide. Though the rink is seemingly heavy and brutal it is truly a tensile structure. The main structure comes from a roughly 90m long central arched backbone of reinforced concrete. From this central support the timber roof is “hung” on a cable net structure which gives it the signature double curve. Further cables running from the central arch to the outer edges of the building help stabilize the structure against wind loads [13].

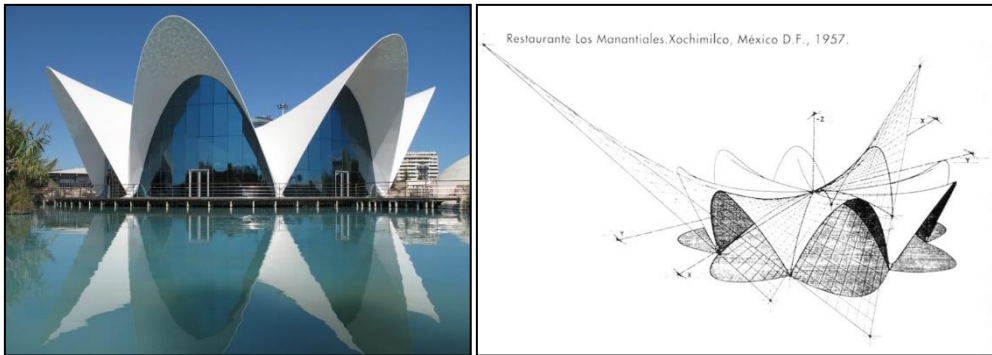


Figure 3. Los Manantiales restaurant by Felix Candela, 1958, after [10,a], [15,b]

In 1958 Felix Candela designed and calculated a masterpiece that which is known among architects around the world until this day. His experiments with construction and thin-shell structures resulted in the design of a restaurant in Xochimilco, Mexico city (Figure 3). Inspired by a form of a flower, the complex building consists of four intersecting hyperbolic paraboloids and blue glass windows opening up to a refreshing canal [10].



Figure 4. Northwestern National Life Insurance Building by Minoru Yamasaki and Associates, 1964, after [10,a], [16,b]

Northwestern National Life Insurance Building (Figure 4) is designed by Minoru Yamasaki and Associates and built in 1964. Now ING Reliastar Building, it is a grand office block that echoes Gothic architecture with its beautiful slim columns and soaring arcs [10]. Yamasaki is most known for his design of the original World Trade Center Towers in New York City. The Northwestern National Life Insurance

Company is completely different in design approach. Slender columns form a portico rising 25 m high. The simple, clean white structure is beautifully proportioned and is an excellent example of the neo-classic, or New Formalist, architectural approach. It has six stories and 20,500 m<sup>2</sup> of office space [17].

The Guggenheim Museum in Bilbao (Figure 5), Spain, is designed by Canadian-American architect Frank Gehry and calculated by Srinivasa “Hal” Iyengar, an eminent Indian American structural engineer known for innovative solutions for difficult projects. The Museum building is a large sculpture made of titanium, limestone, and glass, and has become the most recognizable icon of the city of Bilbao. With 24,000m<sup>2</sup>, of which 9,000 m<sup>2</sup> are dedicated to exhibition space, the Museum represents an architectural landmark of audacious configuration and innovating design, providing a seductive backdrop for the art exhibited in it. Altogether, Gehry’s design creates a spectacular sculpture-like structure, perfectly integrated within Bilbao’s urban pattern and its surrounding area [19]. The museum is one of the most admired works in contemporary architecture. The curves on its exterior were intended to appear random and the randomness of the curves was designed to catch the light [18].



Figure 5. The Guggenheim Museum in Bilbao, Spain, after [18]

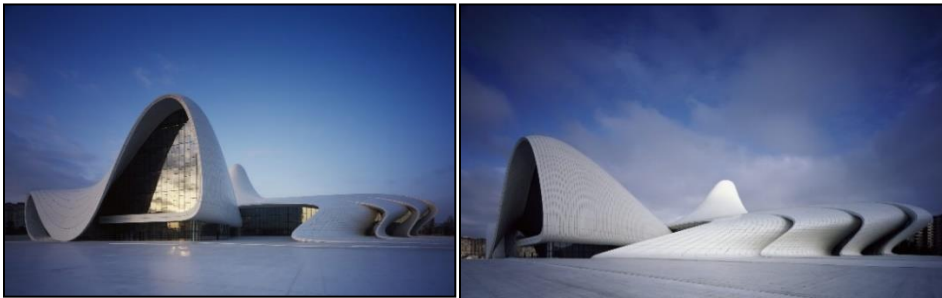




Figure 6. Heydar Aliyev Center, after [20]



Figure 7. City of Arts and Sciences, Valencia, after [22]

The City of Arts and Sciences (La Ciudad de las Artes y las Ciencias) in València is a spectacular and imposing space designed by the architect Santiago Calatrava and Félix Candela and finished in 1998. The outside of the Oceanographic was designed in the form of a water lily by architect Adrián Peláez Coronado, who was born in Valencia. The structural design of the roof was designed by engineers Alberto Domingo and Carlos Lázaro. The City of Arts and Sciences is an ensemble of six areas in the dry river bed of the now diverted River Turia in Valencia, Spain. The "city" is made up of the following, usually known by their Valencian names: El Palau de les Arts Reina Sofía — Opera house and performing arts centre; L'Hemisfèric — Imax Cinema, Planetarium and Laserium; L'Umbracle — Walkway / Garden; El Museu de les Ciències Príncipe Felipe — Science museum; Oceanografic — Open-air aquarium or oceanographic park; Àgora — A versatile space that will allow the holding of varied events [23].



Figure 8. Markthal in Rotterdam, 2014, after [24]

Markthal is the first covered food market of the Netherlands, drawing inspiration from food markets in Stockholm, Barcelona and Valencia. The roof of the market hall is an arch accommodating 228 apartments, underneath the hall are 1,200 parking spaces and a supermarket. The combination of market hall and housing is a new typology and, located in Rotterdam's city center. The construction of Markthal, a design by MVRDV, took five years to be completed. The project was executed by contractors J.P van Eesteren, Mobilis and Martens en Van Oord.

The building with a total surface of 95.000 m<sup>2</sup> was designed by Rotterdam based architecture and urban planning firm MVRDV and structural engineering company Royal HaskoningDHV from the Hague, Netherlands. The arch-shaped hall has a height of 40 meters, inside the arch 228 apartments are situated. The ground floor has a length of about 120 meters and a width of 70 meters, the size of a large football pitch. The underground car park has a total of 1.200 parking lots. Markthal is an energy efficient building [24].



Figure 9. National Museum of Qatar (2019) by Jean Nouvel (Doha, Qatar), after [25], [26]

A series of colliding discs form the external shell and define the internal programme of Atelier Jean Nouvel's National Museum of Qatar, which is based on a mineral formation called the "desert rose". The project is led by Pritzker Prize-winning architect Jean Nouvel and ARUP London structural engineers and it is located on a prominent site within a newly developed civic quarter that connects it with other cultural institutions including I M Pei's Museum of Islamic Art [26].

The building's shape is inspired by the desert rose – a mineral formation created when minerals crystallise below the surface of a salt basin into an array of flat plates resembling rose petals. A steel frame that spans an insulated waterproof



superstructure supports the interlocking discs, which are clad in a glass-fibre reinforced concrete with a sandy hue that evokes the desert landscape. Sections of the building's shell protrude outwards to shade areas of a central courtyard, and to protect the interiors from direct sunlight. Gaps between the discs accommodate frameless glass openings that provide views towards the courtyard, the museum's gardens and the nearby Doha Bay [26].

The museum's 52,000m<sup>2</sup> floor area enfolds the early 20<sup>th</sup>-century palace of Sheikh Abdullah bin Jassim Al Thani, which has been extensively renovated and integrated into the visitor experience. The building's plan forms an elliptical circuit that leads visitors through a sequence of galleries occupying the irregular spaces between the interlocking geometric planes [26].

## 6. CONCLUSIONS

In architecture, some free-form designs deviate from traditional, straight-lined, and regular forms. They can be conventional or non-conventional. Conventional design approach incorporates curves and shapes that are mathematically defined, while non-conventional design approach involves more organic, irregular shapes that are often created through digital means. Free-form geometry allows architects to break free from traditional forms and incorporate more creative and imaginative designs in their work. This type of approach creates unique and visually noticeable, remarkable buildings. However, it represents a great challenge from the aspects of construction and structural engineering. However, with the advancements in technology in both architectural and structural engineering, these challenges can be overcome, allowing for greater freedom and expression in architectural and structural design and better cooperation and understanding between two disciplines [27].

The goal of this paper is to show how important is the understanding and the ability of the structural engineers (constructors) to engage and to be involved in the realization of eccentric ideas of the architects. Some constructors may think that some projects and their structural designs, conceived by the architect's ideas are impossible for realization, but there are exceptional structural engineers who are ready to involve themselves and enable that concept and the idea and make it achievable in reality and material form. It is precisely because of these complex processes that the cooperation between architects and constructors is more important than ever.

## REFERENCES

- [1] Kurtović Folić Nađa, Folić Radomir: **Cooperation between architects and structural engineers in the design of complex reinforced concrete roof structures**, *Proceedings of International conference on Contemporary Theory and Practice in Construction XIII, STEPGRAD, Vol. 1, no. 13, Banja Luka, 2021*
- [2] Saint Andrew: **Architect and Engineer. A Study in Sibling Rivalry**, *Yale University Press New Haven and London, 2007*
- [3] Flury Aita (ed.), **Cooperation: The Engineer and the Architect**, *Birkhäuser, 2011*
- [4] Holgate, Alan: **The Art in Structural Design**, *Oxford, Clarendon Press, 1986*

- 
- [5] Olsen Clare, Mac Namara Sinead: **Collaboration in Architecture and Engineering**, *Routledge (Kindle Edition)*, 2014.
- [6] Pfammatter Ulrich: **The Making of the Modern Architect and Engineer**, *Basel, Birkhäuser*, 2014.
- [7] <https://blog.allplan.com/en/structural-engineering> (February 2018)
- [8] Cengiz Ozmen, Ali Ünay: **Architect – Structural Engineer Collaboration In Sustainable Structural System Design**, *Gazi University Journal of Science*, 2011
- [9] **Improving Collaboration Between Architects and Engineers**, *The Institution of Professional Engineers New Zealand, the New Zealand Institute of Architects, and the New Zealand Registered Architects Board, New Zealand*, 2014
- [10] <https://www.trendir.com/modernist-architecture/> (July 2023)
- [11] <https://www.usafa.edu/facilities/cadet-chapel/> (July 2023)
- [12] <https://archivemodernarchitecture.tumblr.com/post/83805119156/sanctuary-of-the-divine-mercy-kalisz-poland> (July 2023)
- [13] <https://www.archdaily.com/157708/ad-classics-david-s-ingalls-skating-rink-eero-saarinen> (July 2023)
- [14] <https://www.re-thinkingthefuture.com/case-studies/a3392-ingalls-rink-by-eero-saarinen-the-yale-whale/> (July 2023)
- [15] <https://www.math.union.edu/~dpvc/talks/2015-09-30.olivier/model-2c2.html> (July 2023)
- [16] <https://www.claasshaus.com/blog/claass-haus-revisits-the-northwestern-national-life-insurance-building> (July 2023)
- [17] <https://www.docomomo-us-mn.org/northwestern-national-life-insurance-building.html> (July 2023)
- [18] <https://gharpedia.com/blog/features-of-contemporary-architecture-all-you-must-know/> (July 2023)
- [19] <https://www.guggenheim-bilbao.eus/en/the-building> (July 2023)
- [20] <https://www.zaha-hadid.com/architecture/heydar-aliyev-centre/> (July 2023)
- [21] <https://architectuul.com/architecture/heydar-aliyev-center> (July 2023)
- [22] <https://www.visitvalencia.com/en/what-to-see-valencia/city-of-arts-and-sciences/city-of-arts-and-sciences-monuments> (July 2023)
- [23] <http://www.valencia-cityguide.com/tourist-attractions/the-city-of-arts-and-sciences.html>
- [24] [https://www.mvrdv.com/projects/115/markthalhttps://en.wikipedia.org/wiki/Heydar\\_Aliyev\\_Center](https://www.mvrdv.com/projects/115/markthalhttps://en.wikipedia.org/wiki/Heydar_Aliyev_Center) (July 2023)
- [25] <https://www.architecturaldigest.com/story/buildings-redefined-architecture-past-5-years> (July 2023)
- [26] <https://www.dezeen.com/2019/03/28/jean-nouvel-national-museum-qatar-cultural-architecture/#> (July 2023)
- [27] Shawkat Sabah, Ali Hamaradha Chro, Schlesinger Richard, Ivanec Igor: **Free-form geometry in architecture**, *Proceedings of DARCH 2023 April 4th International Conference on Architecture & Design*, 2023

## QUANTITATIVE CHARACTERISTICS OF HIGH INTENSITY RAINFALL IN THE VICINITY OF THE CITY OF NIS

Stevan Prohaska<sup>1</sup>, Aleksandra Ilić<sup>2</sup>, Ognjen Prohaska<sup>3</sup>, Vladislava Bartoš Divac<sup>4</sup>

### Abstract

*The paper presents the analyses of heavy rainfall characteristics that are necessary for design purposes of water management facilities and systems on the small river catchment areas in the vicinity of the city of Niš. All analyzes were primarily completed within the monograph "Intensities of heavy rainfall in Serbia", published by the Institute for the Development of Water Resources "Jaroslav Černi" from Belgrade in 2014, and results are explained and discussed within this paper for the area of the city of Niš. Official historical data from the Database of the Republic Hydrometeorological Service of Serbia are used for the period 1951-2008. In addition to the presented analyses, the rainfall episodes recorded at the main meteorological station (MS) Niš in recent years are analyzed separately. The paper is illustrated with graphical and tabular attachments with appropriate comments and conclusions.*

**Keywords:** *heavy rainfall intensities, rainfall duration, cumulative rainfall, rainfall distribution*

---

<sup>1</sup> Dr., retired full research professor, Institute for the Development of Water Resources "Jaroslav Černi", [stevan.prohaska@jcerni.rs](mailto:stevan.prohaska@jcerni.rs)

<sup>2</sup> Dr., Assistant Professor, Faculty of Civil Engineering and Architecture Niš, [aleksandra.ilic@gaf.ni.ac.rs](mailto:aleksandra.ilic@gaf.ni.ac.rs)

<sup>3</sup> MSc., researcher, Institute for the Development of Water Resources "Jaroslav Černi", [ognjen.prohaska@jcerni.rs](mailto:ognjen.prohaska@jcerni.rs)

<sup>4</sup> MSc., researcher, Institute for the Development of Water Resources "Jaroslav Černi", [vladislava.bartos@jcerni.rs](mailto:vladislava.bartos@jcerni.rs)

## 1. INTRODUCTION

In the water management system design practice in small catchment areas, the main interest is focused on the analysis of the intensity of short-duration rainfall (up to 24 hrs at most), which are the main cause of the catastrophic floods within those areas. With the aim of determining the structure of the formation of the heavy rainfall intensity, the Institute for the Development of Water Resources "Jaroslav Černi", in the cooperation with the Republic Hydrometeorological Service of Serbia, published the monograph "Intensities of heavy rainfall in Serbia", where, among others, relevant data from meteorological station (MS) Niš are presented [1].

Of course, the intensities of heavy rainfall which lasts less than 24 hours can be measured using different types of automatic precipitation measuring devices. There are only few that type instruments in Serbia compared to instruments (rain gauges) for measuring daily precipitation sums. Meteorological station (MS) Niš has measuring equipment for short duration rainfall since 1951, but the Republic Hydrometeorological Service of Serbia has jurisdiction over all precipitation measurements.

In the aforementioned monograph [1], the process of cloud formation and the occurrence of precipitation on the earth's crust is explained and the instruments for measuring precipitation are presented: pluviometers (rain gauges and totalizers) for discontinuous measurement of precipitation, pluviographs for continuous measurement of heavy rainfall and radars that are used to detect area that is affected by precipitation [2], [3]. Two procedures are applied for the pluviograph stripes processing, namely for constant one-hour time period and for different durations of rainfall, whereby the period in which the maximum rainfall depth was measured is considered within the rainfall episode. [4]

In the specific case, this paper shows the following characteristics of heavy rainfall in the vicinity of the city of Niš:

- Average intra-annual patterns of maximum daily precipitation sums and precipitation sums in the rainfall episode with the maximum annual precipitation sum;
- Hyetograph and cumulative line of the annual rainfall episode with the maximum amount of precipitation;
- Dimensionless cumulative lines of the annual rainfall episodes with the maximum amount of precipitation;
- Theoretical dimensionless cumulative lines of heavy rainfall for different probabilities of occurrence;
- Frequency of heavy rainfall;
- Theoretical values of the duration of heavy rainfall for different probabilities of occurrence;
- Frequency of occurrence time of heavy rainfall during the day;
- Dependence of the rainfall depth as a function of the duration and the probability of its occurrence;
- DDF-curves: rainfall depth as a function of duration and frequency;
- Reduction curves of heavy rainfall.

## 2. THE INTENSITY OF HEAVY RAINFALL PROCESSING FOR THE MS NIŠ

Input data can be found in [1].

### 2.1. Intra-annual presentation of the maximum annual precipitation sums with the maximum precipitation sums in the rainfall episode

Percentage of rainy days in year according to the measurements on the MS Niš rain gauge and pluviograph is shown in Figure 1.

The month with the most frequent occurrence of maximum rainfall in Niš is June. In more than 90% of cases, maximum rainfall occur in the period May-September, and the period without occurrence of maximum rainfall is December-January.

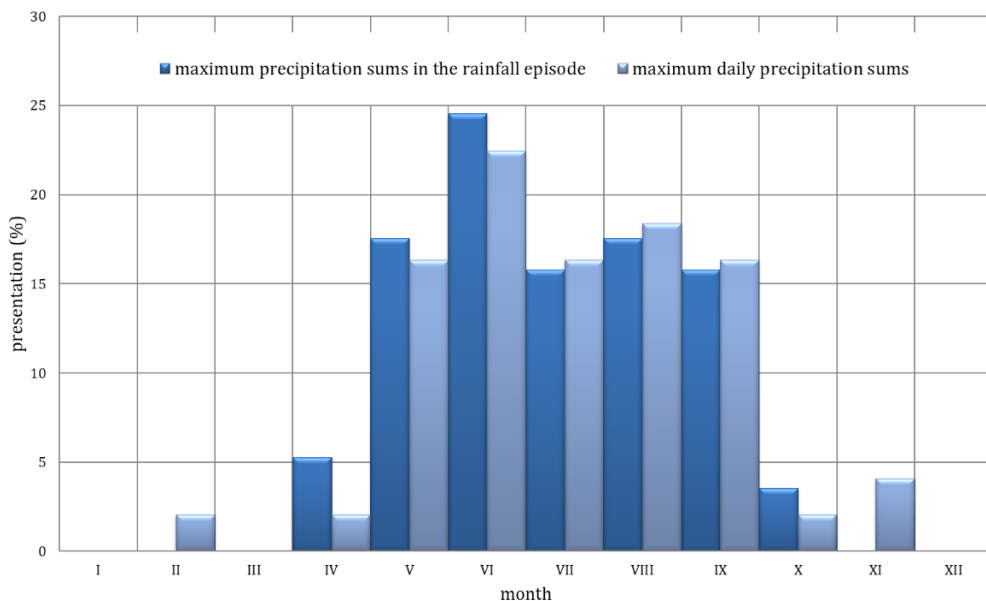


Figure 1. Intra-annual presentation of the maximum annual rainfall amounts measured at the MS Niš rain gauge and pluviograph

### 2.2. Hyetograph and cumulative line of the annual rainfall episode with the maximum amount of precipitation

The distribution character of the rainfall within episode is shown, for example, by hyetograph and cumulative line with the maximum registered precipitation on 12 June 1999 (5:50 pm – 11:00 pm).

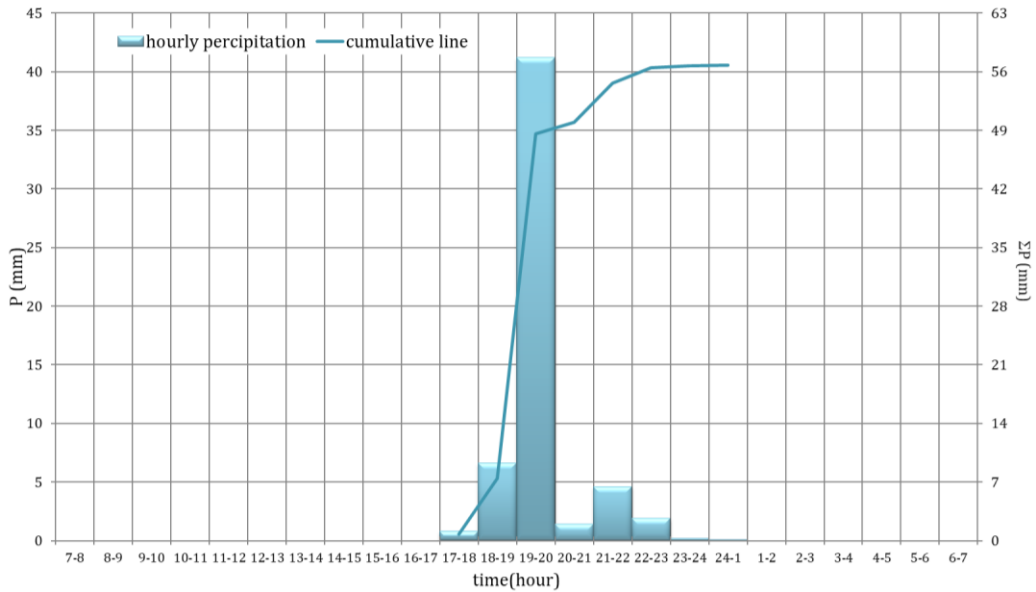


Figure 2. Hyetograph and cumulative line for the rainfall episode with the maximum occurrence of rainfall

### 2.3. Dimensionless cumulative lines for annual rainfall episodes with the maximum precipitation sum

In order to visualize the temporal distribution of rainfall during its duration, dimensionless cumulative lines were defined [5], [6], according to depth and duration. In the specific case, the coordinates of the dimensionless cumulative line are defined:

- Ordinate:

$$\eta_i = \frac{\sum_{j=1}^i P_j}{\sum_{j=1}^{T_k} P_j} \quad (1)$$

- Abscissa:

$$\theta_i = \frac{T_i}{T_k} \quad (2)$$

Where:

$\eta_i$  – ordinate of the dimensionless cumulative line,

$P_j$  – rainfall depth,

$i$  – the number of the characteristic point on the cumulative line ( $i = 1, 2, 3 \dots k$ ),

$j$  – the ordinal number of the rainfall variable,

$\theta_i$  – abscissa of the dimensionless cumulative line,

$T_i$  – rainfall duration for the characteristic point on the cumulative line,

$T_k$  – total rainfall duration.

The results of calculations for MS Niš are shown in Figure 3.

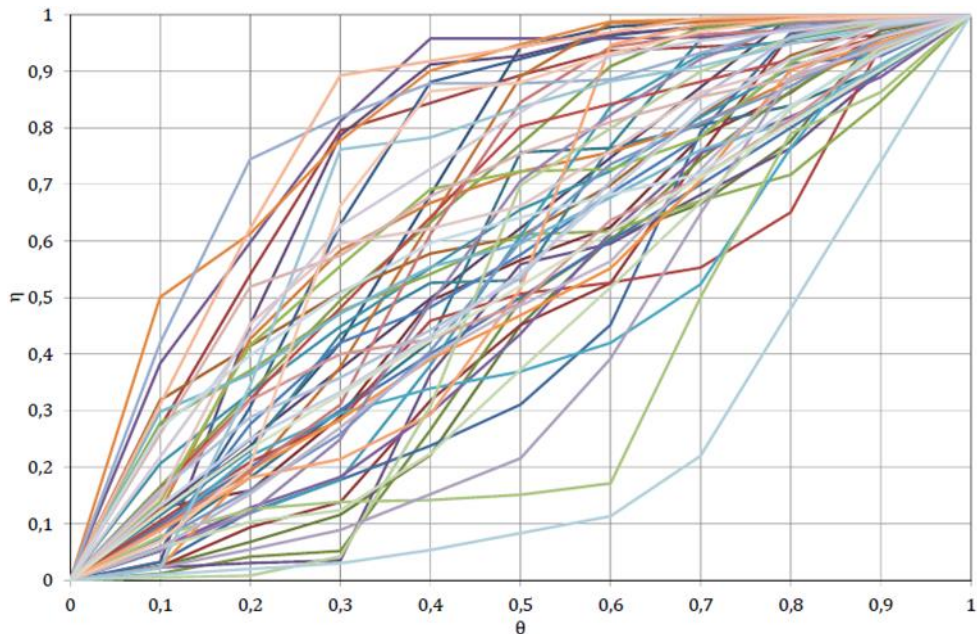


Figure 3. Dimensionless cumulative lines for annual rainfall episodes with the maximum amount of precipitation on MS Niš

Based on the graph shown (Figure 3), it can be concluded that in the area of the city of Niš, there is a great diversity in the character of the formation of rainfall within episode, from very sudden rainfall, to the occurrence of rainfall of moderate intensity, and rainfall with an abrupt ending.

#### 2.4. Theoretical dimensionless cumulative lines of heavy rainfall for different probabilities of occurrence

Based on the defined cumulative lines of rainfall distribution within the episode, using the classic probabilistic procedure for each selected relative duration ( $\tau_i=0.1, 0.2... 1.0$ ), theoretical values (Pearson III law of probability distribution) were calculated for the occurrence probabilities of 10, 20, 50, 80, and 90%. The results of these calculations for MS Niš are shown in Figure 4.

#### 2.5. Frequency of duration of heavy rainfall

The next characteristic of heavy rainfall, very important for urban hydrology, is the duration and frequency of different durations ( $T_k$ ) [5]. It is necessary to emphasize that the most frequent duration of heavy rainfall is significantly shorter than 24 hours, which can be seen in Figure 5, where the frequency of its occurrence in Niš is shown as a function of the duration of the rain.

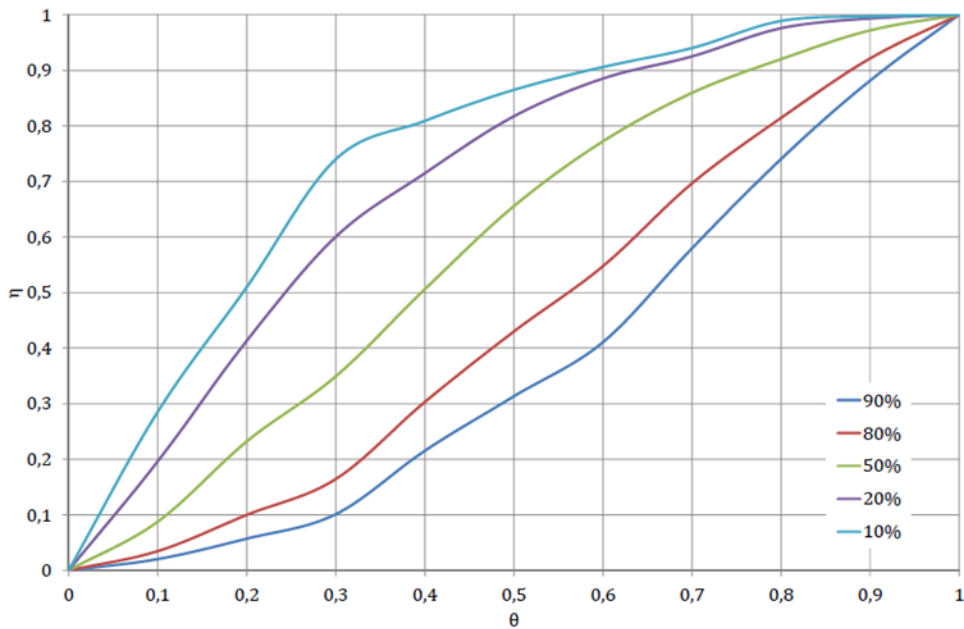


Figure 4. Dimensionless cumulative lines of heavy rainfall for different probabilities of occurrence for MS Niš

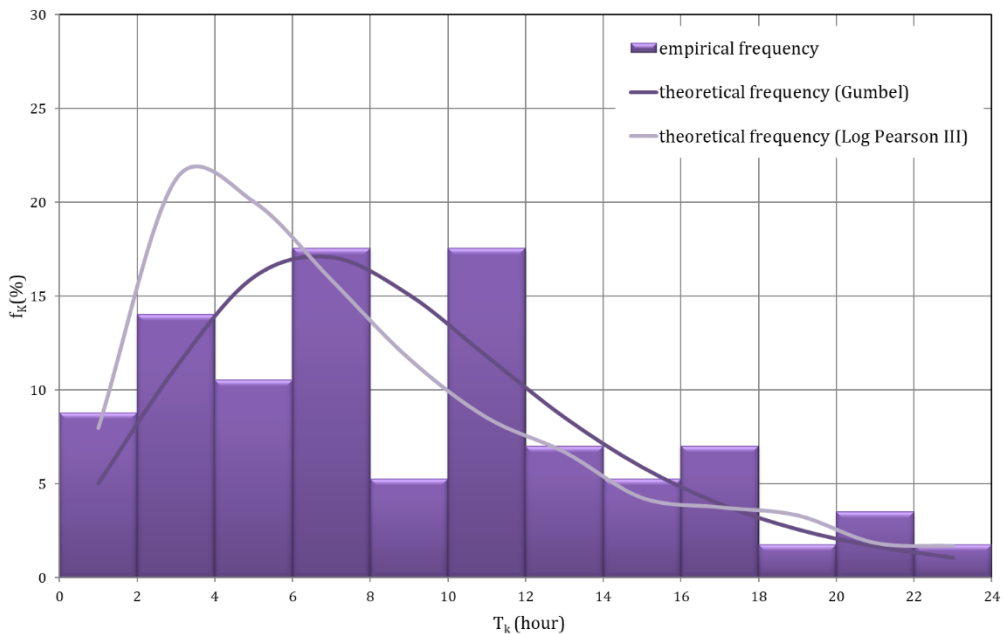


Figure 5. Frequency of duration of heavy rainfall in Niš

As shown in Figure 5, the most frequent duration of heavy rainfall in Niš appear in two periods, from 6 to 8 hr and from 10 to 12 hr, and duration from 2 to 12 hr with a probability of over 60% can be expected.



## 2.6. Probability of total duration of heavy rainfall

The probability of occurrence of the total duration of heavy rainfall in Niš was analyzed applying several laws of probability distribution. The results of the calculation are shown in Figure 6.

Based on the presented results, following Gumbel law of probability distribution, it can be summarized that with a 100-year return period, heavy rainfall can be expected with duration of 29 hours, a ten year return period with 13 hours, and two year return period, heavy rainfall with a duration of 8 hours.

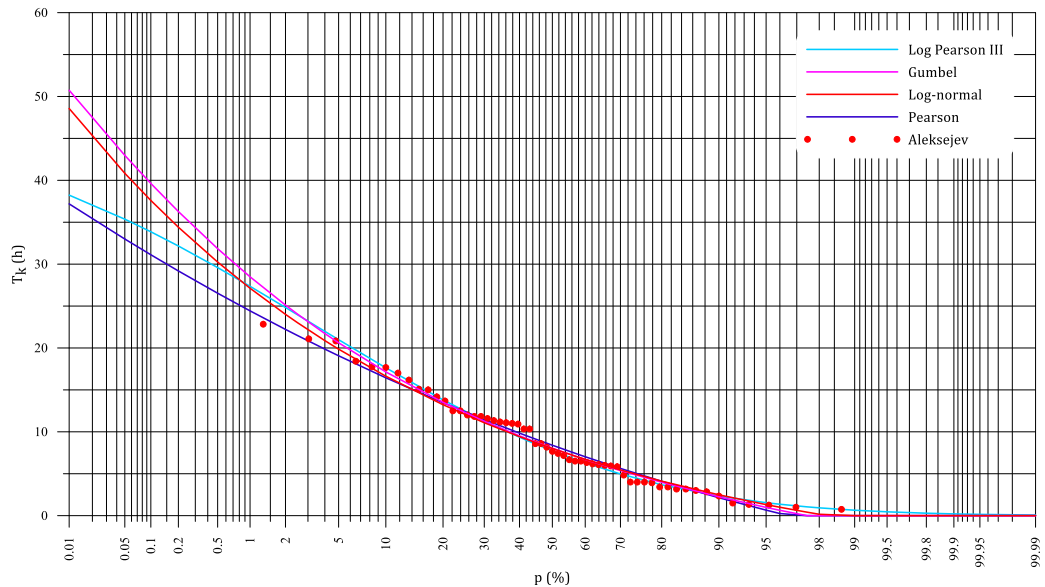


Figure 6. Probability of occurrence of total duration of heavy rainfall in Niš

## 2.7. Frequency of occurrence time of heavy rainfall during the day

One of the very interesting characteristics of heavy rainfall is the probability of heavy rainfall time of occurrence in one day (24 hours). For this purpose, an analysis of the frequency and probability of the occurrence time of rainfall during the day was performed using available hourly rainfall data of the maximum rainfall episodes registered [1], [3], [7]. The results of the calculation of the frequency of the occurrence time of heavy rainfall during the day for MS Niš are shown in Figure 7.

Based on these results, it can be concluded that heavy rainfall in Niš occurs between 7 pm and 9 pm. The rainfall will occur between 3 pm and 3 am next day with 70% of probability. The period with the least probability of heavy rainfall occurs from 7 am to 9 am.

## 2.8. Dependence of rainfall depth as a function of rainfall duration and probability of occurrence

The identification of heavy rainfall of shorter duration than a day, with the maximum amount of precipitation, is also carried out by the process of moving selected maximum amounts of rainfall for predefined periods of time, i.e. duration of rainfall [4]. The maximum annual intensities were processed for the 10, 20, 30, 60, 120, 360, 720 and 1440 minutes rainfall durations. The annual maximum daily precipitation sums are also included, registered on the rain gauge.

For the specified durations of rainfall, the probabilities of the occurrence of a rainfall depth and its intensity are calculated, using theoretical probability distribution curves. Applied goodness-of-fit tests showed that Gumbel distribution best fit. Based on these data, the dependences of the depth as a function of the duration and the probability of occurrence for MS Niš are shown in Figures 8 and 9.

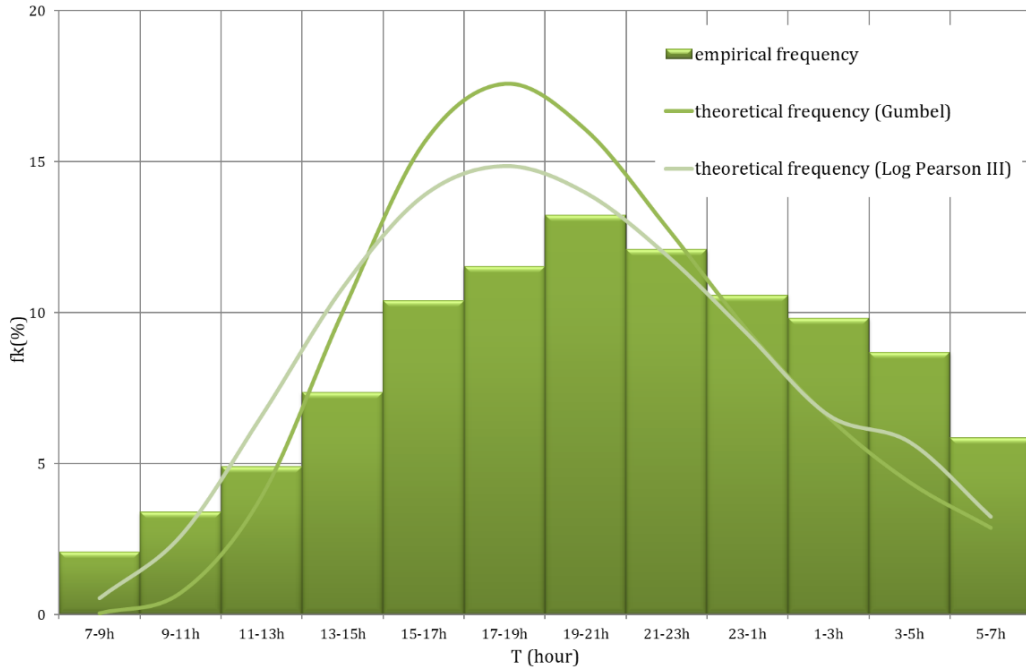


Figure 7. Frequency of occurrence time of heavy rainfall during the day on MS Niš

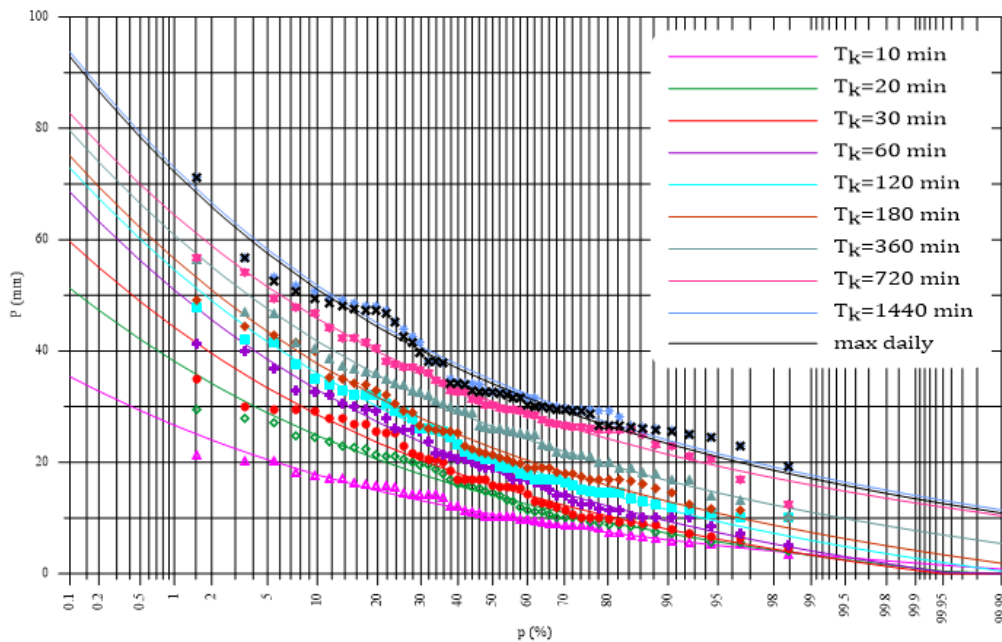


Figure 8. Dependence of rainfall depth as a function of probability of occurrence and duration for MS Niš

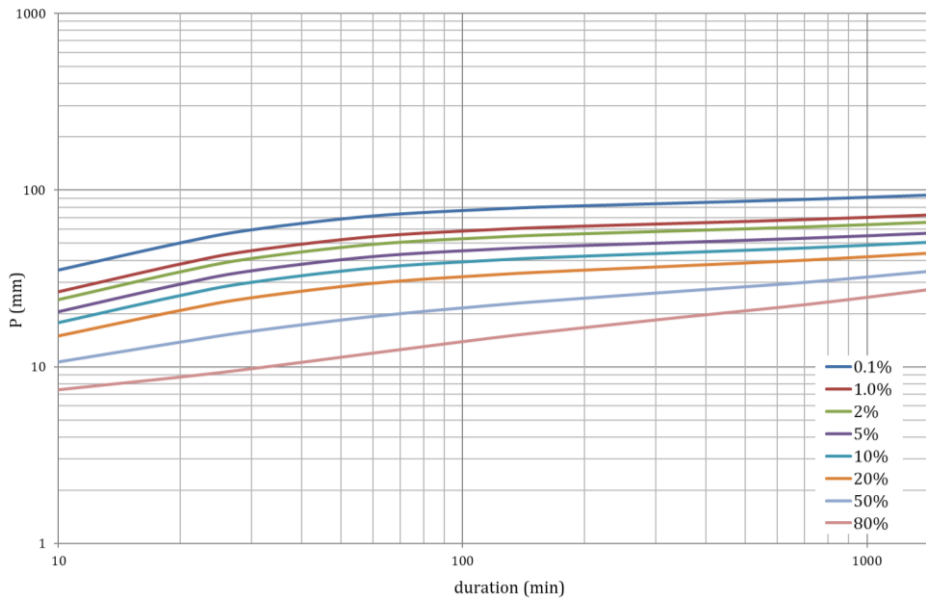


Figure 9. Dependence of rainfall depth as a function of duration and probability of occurrence for MS Niš

### 2.9. Reduction curves of heavy rainfall

The reduction curves of heavy rainfall  $\psi(\tau)$ , present the ratio of the maximum depth for any rainfall duration  $\tau_i$  and the corresponding daily rainfall (24 hours duration) [5], i.e:

$$\psi(\tau) = \frac{P_{\tau_i}}{P_{24}} \quad (3)$$

Defined reduction curves of heavy rainfall for MS Niš are shown in Figure 10.

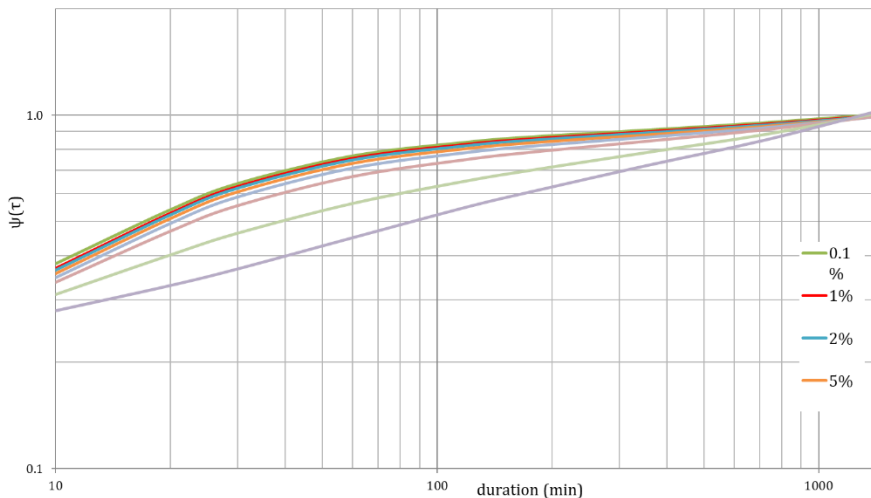


Figure 10. Reduction curves of heavy rainfall for MS Niš

The reduction curve is used to assess the amount of rainfall of any duration when only the probability of occurrence of 24hr rainfall is known.

### 3. CONCLUSION

The aim of this paper is to provide the basic characteristics of heavy rainfall, as a necessary basis for the design of water management facilities and systems on small catchments in the vicinity of the city of Niš. The presented results are given in Figures 1 to 10, while numerical values can be found in the monograph [1].

### REFERENCES

- [1] Prohaska Stevan, Bartoš Divac Vladislava, Koprivica Ana, Đukić Dragan, Ilić Aleksandra, Čatović Samir, Kapor Branka, Marjanović Srđan, Vukelić Vanja, Božović Nikola: **Inteziteti jakih kiša u Srbiji**, *Institut za vodoprivredu „Jaroslav Černi“*, ISBN 978-86-82565-40-6, str. 481, 2014. (In Serbian)
- [2] Prohaska Stevan: 2003: **Hidrologija I deo**, *Rudarsko-geološki fakultet, Institut za vodoprivredu "Jaroslav Černi", Republički hidrometeorološki zavod Srbije*, Beograd, 2003. (In Serbian)
- [3] Prohaska Stevan., Ristić Vakanjac Vesna: **Hidrologija kroz teoriju i praksu**, *Univerzitet u Beogradu, Rudarsko-geološki fakultet*, Beograd, 2002. (In Serbian)
- [4] Prohaska Stevan, Kapor Branka, Ilić Aleksandra, Čatović Samir., Marjanović Srđan, Bartoš Divac Vladislava., Koprivica Ana: **Kompleksna analiza pluviometrijskog režima jakih kiša kraćih trajanja na teritoriji Republike Srbije**, *Časopis „Voda i sanitarna tehnika“*, Vol. 41, No. 3-4, 2011., ISSN 0350-5049, str. 5-14, 2011. (In Serbian)
- [5] Prohaska Stevan, Petković Tioslav: **Metode proračuna velikih voda**, Deo I, *Proračun velikih voda na hidrološki izučanim profilima, Građevinski kalendar*, Beograd, 1989. (In Serbian)
- [6] Prohaska Stevan, Bartoš Divac Vladislava, Prohaska Ognjen: **Kvantitativne karakteristike kiša jakog intenziteta u okolini Palića sa aspekta projektovanja kišne kanalizacije**. *Konferencija „VODA 2023“*, 2023. (In Serbian)
- [7] Janković Dragan: **Karakteristike jakih kiša na teritoriji Srbije**, *Građevinski kalendar*, Beograd, 1994. (In Serbian)

# STABILITY OF COMPRESSED CHORD OF HALF-THROUGH TRUSS GIRDERS IN BRIDGE CONSTRUCTION ACCORDING TO EUROCODE WITH CASE STUDY

Aleksandar Stojanović<sup>1</sup>, Jovan Anđelković<sup>2</sup>

## Abstract

*Half-through truss spatial girders consist of two parallel vertical trusses and one horizontal truss at the level of the lower chord of the vertical trusses. This type of construction is suitable for bridges since pedestrians and vehicles can move on the lower horizontal truss without obstruction in the form of the upper horizontal truss. However, the problem of this type of construction arises in the form of the loss of stability of the upper chord of the vertical trusses, as there are no lateral support points in the horizontal plane, so the buckling length is practically equal to the length of the girder (which is typical for spans of 10-20m in industrial pipe bridges). However, the buckling of the upper chord is to some extent prevented by the bending stiffness of the transverse "half-frames" (a "half-frame" is formed by the verticals of the vertical trusses and the "vertical" of the horizontal truss). In this way, the compressed upper chord can be analyzed as a beam discretely supported on elastic supports in the horizontal plane, and for such a beam, the real buckling lengths of the upper chord can be determined. This problem is covered by the standard SRPS EN 1993-2. For the purpose of verifying the existing state of a transport bridge within an industrial complex, an analysis of a half-through truss girder made of hot-rolled profiles was performed, and for the purpose of practical calculation, a calculation model was created in Microsoft Excel software for faster analysis. The results from that model were compared with the results obtained from the Finite Element Analysis of the beam discretely supported on elastic supports with a certain stiffness.*

**Keywords:** *Half-through truss girders, stability of upper chord of truss girders, beams on elastic supports, Finite Element Analysis (FEA), Eurocode 3-2*

---

<sup>1</sup> MSc Civil Engineer, Structural engineer at Facade Engineering d.o.o and Axis Građevinski Biro d.o.o, astojanovicgr@gmail.com

<sup>2</sup> PHD student, Structural engineer at Facade Engineering d.o.o, jovandzina@gmail.com

## 1. INTRODUCTION

Half-through steel bridges are commonly used as railway bridges, as pedestrian bridges, and bridges in industrial complexes such as pipeline bridges where a service path is needed along pipes. Two types of cross sections can be defined, one that contains two parallel girders made of welded I section connected with perpendicular cross-beam which carry rail or pedestrian paths. The second cross-section can be found in truss half-through bridges which contain two parallel trusses which are connected with a perpendicular cross beam at the bottom chord. In both cross sections, the upper chord (or upper flange) is not connected with the second, parallel truss (girder) as trains and pedestrians need to move along the bridge. In this paper truss type of bridge used in industrial complexes is analyzed.

Industrial truss bridges are most commonly designed as simply supported beams. In this structural system, for usual loads, the upper chord is compressed and the bottom chord is in tension. The bottom chord has a perpendicular beam connected to the other truss so buckling length can be considered in both planes (plane of truss and plane out of truss) to be equal to horizontal distances of truss verticals. This would be more helpful to the upper chord since this chord is compressed and its stability is more vulnerable. The upper chord can be designed in a way that the buckling length in the plane of the truss is equal to the horizontal distance of verticals and the buckling length out of the truss plane is equal to the full bridge length but since industrial bridge spans are often above 10m or 15m this can lead to uneconomical design.

A more economical design can be accomplished if the “U-Frame” action is used in the calculation. This approach allows designing the upper chord as a beam discretely supported on elastic supports. Elastic support is a “U-Frame” which consists of verticals from both parallel trusses and the bottom perpendicular beam that connects bottom chords. The stiffness of elastic supports is determined by the function of flexural stiffness of the “U-Frame”.



Figure 1. Half-through bridge types

## 2. U-FRAME ACTION

The flexural stiffness of a U-Frame is most important for the structural behavior of half-through bridges. The designer can implicate stiffness by selecting various profiles for verticals, bottom horizontals, diagonals, and chords. Besides selecting profiles (cross-sections) they can also make stiffer connections between a vertical and horizontal beam of U-Frame increasing the whole stiffness of the U-Frame. Designing semi-rigid connections, the stiffness of the U-Frame will decrease since it would be “easier” to move the top point of the vertical than if the connection is designed as rigid.

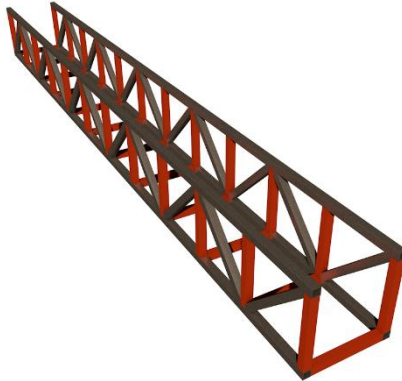


Figure 2. U-Frames in truss bridge (orange)

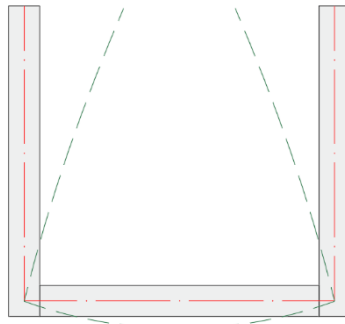


Figure 3- Flexural deformation of U-Frame

### 2.1. Calculating U-Frame stiffness [1]

Using SRPS EN 1993-2:201 [2], for a typical U-Frame shape, stiffness ( $C_d$ ) can be calculated as:

$$C_d = \frac{EI_v}{\frac{h_v^3}{3} + \frac{h^2 b_q I_v}{2I_q}} \quad (1)$$

If connection rigidity needs to be accounted for, this can be done as follows:

$$C_d = \frac{EI_v}{\frac{h_v^3}{3} + \frac{h^2 b_q I_v}{2I_q} + \frac{h^2 EI_v}{S_j}} \quad (2)$$

For equations (1) and (2):

$I_v$  – second moment of area of the vertical

$I_q$  – second moment of area of the horizontal beam

$h_v$  – the distance between the top of the horizontal beam and centroid of the top chord

$h$  – the distance between the centroid of the top chord and the centroid of the horizontal beam

$b_q$  – spacing of main trusses (verticals)

$S_j$  – stiffness of the connection

$E$  – Elastic modulus

The stiffness of the U-frame can be calculated using FE analysis. A model needs to be prepared and pair of forces (horizontal) need to be applied in the top chord (usually  $F=1\text{kN}$ ). By dividing load with measured deflection stiffness of U-Frame can be obtained.

$$C_d = \frac{Y_{FE,software}}{F} \quad (3)$$

Where:

$Y_{FE,software}$  – horizontal displacement of top chord measured in FE software

$F$  – Force applied in the top chord (pair of horizontal forces, usually  $F=1\text{kN}$ )

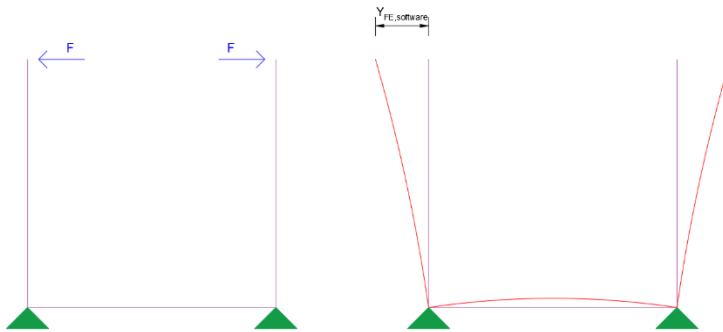


Figure 4. Forces and deflection for calculating stiffness of U-Frame

Based on calculated U-Frame stiffness elastic critical buckling force can be calculated in two ways – analytical or by FE model.

The direction for analytical calculation is shown in standard SRPS EN 1993-2:2012 [2], which is shown in the following:

$$N_{crit} = mN_E \quad (4)$$

$$N_E = \frac{\pi^2 EI}{L^2} \quad (5)$$

$$m = \frac{2}{\pi^2} \sqrt{\gamma} \geq 1 \quad (6)$$



$$\gamma = \frac{cL^4}{EI} \tag{6a}$$

$$c = \frac{C_d}{l} \tag{6b}$$

Where:

E- Elastic modulus

L – the distance between rigid braces

l - U-Frame spacing

The top chord (compressed member) buckling length can be calculated from equation (4) as:

$$l_{crit} = \sqrt{\frac{\pi^2 EI}{N_{crit}}} \tag{7}$$

Critical force calculated using equation (4) is based on the assumption that end frames are rigid. In real construction, this usually is not achieved and the stiffness of end frames can be accounted for in equation (4) by replacing factor m with  $m_e$ .

$$m_e = \frac{\sqrt{\gamma}}{\left(\frac{\pi}{\sqrt{2}} + \frac{0.69}{X+0.5}\right)^2} \tag{8}$$

$$X = \frac{C_e}{\sqrt{2}} \left(\frac{l^3}{C_d^3 EI}\right)^{0.25} \tag{8a}$$

Where:

$C_e$  – stiffness of end frame calculated per equation (1) or (2).

### 2.2. Comparison of analytical and FE results for buckling length.

For practical analysis Excel spreadsheet is formed. This gives opportunity to the designer to try different cross sections of truss elements to find most economic solution for design.

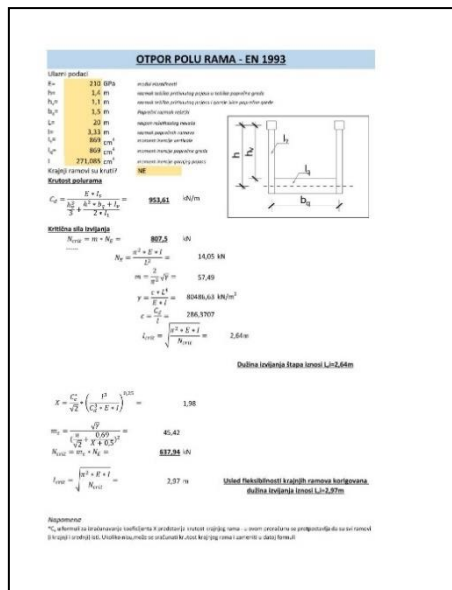


Figure 5. Report from Excel spreadsheet

To confirm results obtained from custom made Excell spreadsheet, FE model is made. Cross-sections and frame spacing are varied. Stiffness of elastic support is calculated using equation (1) and this value is set as support stiffness in horizontal direction (in vertical direction beam is supported as simply supported).

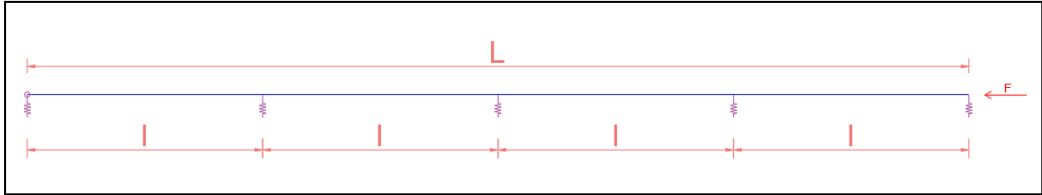


Figure 6. FE model for buckling analysis

Buckling analysis is performed and buckling length are obtained in software. This buckling lengths are compared with those obtained from Excell.

Table results are shown below

Table 1. Buckling lengths obtained in FEA software

DUŽINE IZVIJANA – SCIA ENGINEER							
Razmak poluramova			6,67	5,00	3,30	2,00	1,25
50x50x3	Cd=	21,36	<b>8,58</b>	<b>8,21</b>	<b>7,86</b>	<b>7,42</b>	<b>6,89</b>
100x100x5	Cd=	297,48	<b>6,67</b>	<b>5,00</b>	<b>3,73</b>	<b>3,41</b>	<b>3,21</b>
IPE 160	Cd=	953,61	<b>6,67</b>	<b>5,00</b>	<b>3,30</b>	<b>2,45</b>	<b>2,28</b>
IPE220	Cd=	3039,71	<b>6,67</b>	<b>5,00</b>	<b>3,30</b>	<b>2,02</b>	<b>1,64</b>

Table 2. Buckling lengths obtained from Excell (min. buck. length equal to frame distance)

DUŽINE IZVIJANA EXCELL – dužina izvijanja ne može biti manja od razmaka pluramova							
Razmak poluramova			6,67	5,00	3,30	2,00	1,25
50x50x3	Cd=	21,36	<b>9,52</b>	<b>9,07</b>	<b>8,49</b>	<b>7,82</b>	<b>7,25</b>
100x100x5	Cd=	297,48	<b>6,67</b>	<b>5,00</b>	<b>4,08</b>	<b>3,75</b>	<b>3,47</b>
IPE 160	Cd=	953,61	<b>6,67</b>	<b>5,00</b>	<b>3,30</b>	<b>2,71</b>	<b>2,51</b>
IPE220	Cd=	3039,71	<b>6,67</b>	<b>5,00</b>	<b>3,30</b>	<b>2,00</b>	<b>1,82</b>

Table 3. Ratio of buckling lengths obtained from Excell and FEA software

$L_{crit,excel}/L_{crit,software}$							
Razmak poluramova			6,67	5,00	3,30	2,00	1,25
50x50x3	Cd=	21,36	<b>1,11</b>	<b>1,11</b>	<b>1,08</b>	<b>1,05</b>	<b>1,05</b>
100x100x5	Cd=	297,48	<b>1,00</b>	<b>1,00</b>	<b>1,09</b>	<b>1,10</b>	<b>1,08</b>
IPE 160	Cd=	953,61	<b>1,00</b>	<b>1,00</b>	<b>1,00</b>	<b>1,11</b>	<b>1,10</b>
IPE220	Cd=	3039,71	<b>1,00</b>	<b>1,00</b>	<b>1,00</b>	<b>0,99</b>	<b>1,11</b>

### 3. PRACTICAL DESIGN

For the purpose of process modernization in the oil industry, verification of the existing pipeline bridge needed to be done.

The type of bridge is a half-through truss bridge connected at the level of the bottom chord with a cross beam and diagonals (horizontal truss). The service path is designed at one side of the bridge and the path is made of checkered plate supported on longitudinal beams that are supported by cross beams. The structural system of the bridge is simply a supported beam with a span of  $L=15\text{m}$

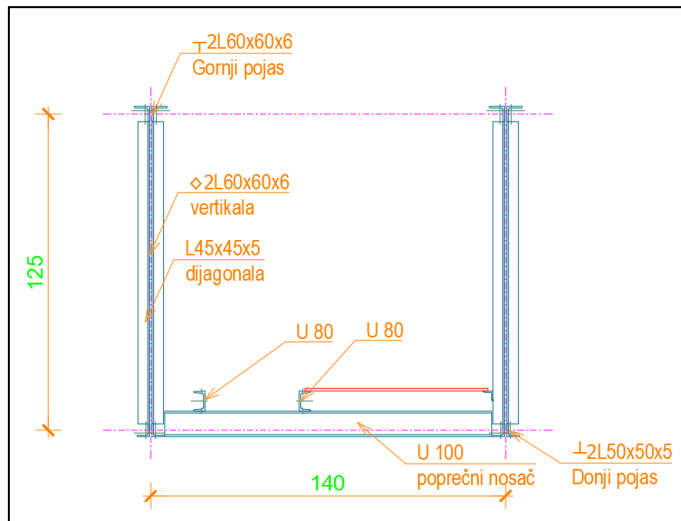


Figure 7. Pipeline bridge cross-section (existing)

Cross sections:

- Top chord : 2L60x60x6
- Bottom chord: 2L50x50x5
- Vertical: 2L60x60x6
- Diagonal: L45x45x5
- Cross-beam: U100

Mechanical design showed that there will be 35% higher load than in original design.

Truss model in FEA software was modeled along with all loads. All load combinations are considered as referred in Eurocode standard (SRPS EN 1990:2012)[3]. In original design [4] U-Frame action is considered using standard JUS U.E7.106:1980[5].

Top chord is checked first neglecting U-Frame action using whole bridge length as buckling length in direction outside of truss plane. This calculation showed that stronger cross section need to be used. Since this was not acceptable, U-Frame action is used in to account.

Buckling length is calculated using Excell spreadsheet as follows:

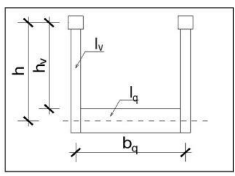
### OTPOR POLU RAMA - EN 1993

**Ulazni podaci**

E=	210	GPa	modul elastičnosti
h=	1,25	m	razmak težila prisilnog pojasa u težila poprečne grede
h <sub>0</sub> =	1,1175	m	razmak težila prisilnog pojasa i gornje ivice poprečne grede
b <sub>0</sub> =	1,4	m	Poprečni razmak rešetki
L=	15	m	raspon rešetkastog nosača
l=	1,5	m	razmak poprečnih ramova
I <sub>y</sub> =	72,2	cm <sup>4</sup>	moment inercije vertikale
I <sub>0</sub> =	206	cm <sup>4</sup>	moment inercije poprečne grede
I	170	cm <sup>4</sup>	moment inercije gornjeg pojasa

Krajnji ramovi su kruti? **NE**

**Krutost polurama**

$$C_d = \frac{E \cdot I_y}{\frac{h_0^3}{3} + \frac{h^2 \cdot b_0}{2} + I_0} = 178,69 \text{ kN/m}$$


**Kritična sila izvijanja**

$$N_{crit} = m \cdot N_E = 412,4 \text{ kN}$$

$$N_E = \frac{\pi^2 \cdot E \cdot I}{L^2} = 15,66 \text{ kN}$$

$$m = \frac{2}{\pi^2 \sqrt{\gamma}} = 26,34$$

$$\gamma = \frac{c \cdot L^4}{E \cdot I} = 16892,66 \text{ kN/m}^2$$

$$c = \frac{C_d}{I} = 119,1245$$

$$l_{crit} = \sqrt{\frac{\pi^2 \cdot E \cdot I}{N_{crit}}} = 2,92 \text{ m}$$

**Dužina izvijanja štapa iznosi L<sub>i</sub>=2,92m**

$$X = \frac{C_c}{\sqrt{2}} \cdot \left( \frac{l^3}{C_d^2 + E \cdot I} \right)^{0,25} = 0,81$$

$$m_e = \frac{\sqrt{\gamma}}{\left( \frac{\pi}{\sqrt{2}} + \frac{0,69}{X + 0,5} \right)^2} = 17,19$$

$$N_{crit} = m_e \cdot N_E = 269,19 \text{ kN}$$

$$l_{crit} = \sqrt{\frac{\pi^2 \cdot E \cdot I}{N_{crit}}} = 3,62 \text{ m}$$

**Usled fleksibilnosti krajnjih ramova korigovana dužina izvijanja iznosi L<sub>i</sub>=3,62m**

*Napomena*  
 \*C<sub>c</sub> u formuli za izračunavanje koeficijenta X predstavlja krutost krajnjeg rama - u ovom proračunu se pretpostavlja da su svi ramovi (i krajnji i srednji) isti. Ukoliko nisu, može se sračunati krutost krajnjeg rama i zameniti u datoj formuli

Figure 8. The buckling length of the top chord was calculated in an Excel spreadsheet

The top chord is checked with this buckling length but results showed that new loads are still higher than the originally designed bridge can carry. The proposed solution for this problem was to remove the service path (removing the dead load, snow load, and live load) and connect the top chord with cross beams and diagonals – making a closed cross-section of the bridge. This solution was accepted by the customer.

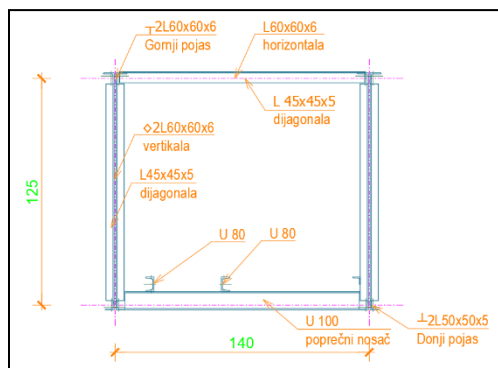


Figure 9. Pipeline bridge cross-section (new design)

## 4. CONCLUSION

Including U-frame action into account for the stability of top chord in half-through truss bridges can lead to more efficient and economical design.

Calculated cross sections with U-Frame action are smaller than calculating stability of top chord using whole bridge length as buckling length.

Also outside diagonals that are often used for stability of top chord can be avoided (less steel usage, less work).

Using analytical formulas along with Excel spreadsheet can save a lot of time for calculating buckling lengths and appropriate cross sections than creating FEA model, varying cross sections and do buckling analysis for every case.

Compared results shows that Excell results are below 10% different than FEA results, on safety side.

Further analysis can be made for calculating buckling lengths on whole 3D model of bridge using in account all elements of bridge.

## REFERENCES

- [1] Pimentel Ricardo : **U-Frame action design according to Eurocodes**. *NEW STEEL CONSTRUCTION*, Volume 29 No 1, 24-28, 2021.
- [2] **SRPS EN 1993-2:2012**, Evrokod 3 – Projektovanje čeličnih konstrukcija – Deo 2: Čelični mostovi
- [3] **SRPS EN 1990:2012**, Evrokod – Osnove projektovanja konstrukcija
- [4] **TRANSPORTNI MOSTOVI**. Knjiga 1, sveska 4, Institut za hemiju, tehnologiju i metalurgiju, Beograd, 1978.
- [5] JUS. U.E7.106:1980 – Stabilnost nosećih čeličnih konstrukcija – Pritisnuti štapovi sa elastičnim poprečnim osloncima.

# PUBLIC PARTICIPATION SUPPORTING URBAN SUSTAINABILITY TRANSITION: RECENT EXPERIENCES FROM PLANNING AND GOVERNANCE PRACTICE IN SERBIAN CITIES

Nataša Čolić<sup>1</sup>, Marina Nenković-Riznić<sup>2</sup>, Marijana Pantić<sup>3</sup>

## Abstract

*Sustainability transition in urban settings requires planning and governance practice to re-evaluate and reimagine the local community's quality of life, including but not limited to the domains of social wellbeing and accessibility to the services of general economic interest and public space, sustainable forms of commuting, climate change adaptation, green and low carbon development and economy, environmental protection and disaster risk reduction (Green Agenda for the Western Balkans, 2020). The general public and non-experts have an important role in informing planning policy and practice about current needs, capacities and anticipated risks in urban settings, which calls for re-examining of the traditional decision-making hierarchies. Serbia recently adopted a cycle of policy documents supporting participatory action at all levels of decision-making in line with the opening of Chapter 22 – Regional policy and coordination of structural instruments as part of the European Union accession trajectory, as well as the sub-goal 11.3 of the United Nations Agenda 2030 to enhance inclusive and sustainable urbanization and capacity for participatory, integrated and sustainable planning and governance in human settlements. This paper outlines the objectives and instruments for the operationalization of public participation in the recent policy framework and discusses some of the practical experiences in planning and governance in ten Serbian cities. Methods used were semi-open questionnaires with representatives of local urban planning departments, qualitative content analysis of adopted urban plans, publicly available reports on conducted citizen participation and stakeholder involvement, and local strategic documents, and, participant observation at joint workshop with city representatives. The results indicate that urban planning and governance practices require space for learning and experimentation, where open and inclusive participation, as well as related empowerment, represent a necessary condition for an urban sustainability transition. The undertaken research with city representatives was supported by the World Bank Group and SECO project "Technical assistance: Strengthening capacities of local self-governments in Serbia towards low-carbon and resilient urban development investments".*

**Keywords:** *public participation, governance, sustainable urban development, sustainability transition*

---

<sup>1</sup> Dr., Research Associate, Institute of Architecture and Urban & Spatial Planning of Serbia, [natasac@iaus.ac.rs](mailto:natasac@iaus.ac.rs)

<sup>2</sup> Dr., Senior Research Fellow, Institute of Architecture and Urban & Spatial Planning of Serbia, [marina@iaus.ac.rs](mailto:marina@iaus.ac.rs)

<sup>3</sup> Dr., Senior Research Fellow, Institute of Architecture and Urban & Spatial Planning of Serbia, [marijana.d.pantic@gmail.com](mailto:marijana.d.pantic@gmail.com)

## 1. INTRODUCTION

Joint programs, projects, and initiatives for strengthening deliberative practices in sustainable urban development have been widely diffused across Europe. The real needs of cities impose the urgency for the development of professional planning competencies, institutional capacities and academic progression in transition to the more sustainable forms of urban governance [1]. One of the policy objectives of the Cohesion Policy of the European Union (EU) 2021-2027 [2] is Europe closer to citizens by fostering the sustainable and integrated development of all types of territories responding to the challenges of cities. As one of those challenges, the Covid-19 pandemic between 2020 and 2022 has demonstrated that the emergence of new conditions and new problems cannot be solved solely by traditional planning and government regulations, or market instruments [3], but require re-evaluation of their political, economic, and social structures. In addition, the lack of public resources places pressure on cities' networks to achieve ambitious goals, giving urban governance and citizen engagement an important role in the allocation of material, but also knowledge and skills resources [4, 5, 6]. Southeast Europe countries, namely non-EU members with pre-accession status such as Serbia, still have limited experience in participatory and integrated sustainable urban development due to lower institutional capacities and reduced access to funding for testing and innovation.

The local context of Serbia is characterised by the economic transition, as well as regulations that do not follow the speed of the EU policy [7]. Over the past decade, several initiatives have been undertaken to raise awareness about sustainable urban development in Serbia, aligning with the EU Cohesion Policy 2021-2027. These efforts have focused on enhancing administrative capacities and fostering regional and cross-border cooperation (goal 5 of the EU Cohesion Policy – Europe close to its citizens). One significant outcome of these endeavours is the adoption of the Sustainable Urban Development Strategy of Serbia 2030 (2019), demonstrating the national government's dedication to implementing a framework for sustainable urban development [8]. The framework for implementation of the Strategy emphasizes the participatory approach in identifying the priority areas of spatial intervention and formation of local governance pathways in urban areas. The aim is to support sustainable urban transition in a bottom-up fashion, where urban governance represents “the pursuit of collective goals through an inclusive strategy of resource mobilisation” [9].

Several Serbian cities initiated the formation of local integrated urban development strategies for inner-city areas backed up by technical support of international organisations such as the United Nations Human Settlements Programme (UN-Habitat) in 2007 and the German Agency for International Cooperation (GIZ) in 2013. The EU PRO Plus programme for local economic development, implemented by the United Nations Office for Project Services (UNOPS), continued these efforts by financing and providing technical support for the formation of twelve sustainable and integrated territorial development strategies covering the territory of thirty-one Serbian cities and municipalities (2021-ongoing). Additionally, World Bank and Swiss State Secretariat for Economic Affairs (SECO) technical assistance project is directed towards strengthening the capacities of local self-governments in Serbia towards low-carbon and resilient urban development investments in ten Serbian cities (2021-ongoing). The common objective of these

programs is to strengthen the capacity for urban sustainability transition through participatory action.

This paper refers to the research undertaken within the World Bank and SECO project for strengthening the capacities of local self-governments towards low-carbon and resilient urban development investments. The undertaken research aims to understand to which extent participation at the levels of informing, consultations and active participation serves as a base for transformative action supporting sustainability transition in ten Serbian cities [10]. The research results are contextualised in line with the objectives and instruments for the operationalization of public participation in the recent policy framework.

## 2. METHODOLOGY

Research design is tailored towards the understanding of the existing participation capacities of cities in urban planning and governance practice. The research methodology identifies the cases in which participatory action was incorporated within formal planning procedures to enhance the transparency of the planning process. In addition, the research was seeking an understanding of the planning professionals' efforts to identify the needs and interests of diverse actors to enhance more realistic planning and/or policy concept.

A purposeful sampling strategy by collecting expert knowledge of planning practice in a real-world setting aims to inform the formation of a more responsive planning policy [11]. Case studies in this research are ten Serbian cities: Kragujevac, Kraljevo, Leskovac, Niš, Novi Pazar, Šabac, Novi Sad, Sombor, Užice, and Zrenjanin. The case selection was predetermined by the mandate of the World Bank Group and SECO project.

The initial stage of the research performed in January 2022 identified the current policy framework for implementation of citizen participation and stakeholder engagement through desk-based analysis of recently adopted national acts in the domains of EU integration, planning, governance, local administration, social cohesion, and gender equality. Gathered quotes from the policy documents served as a starting point in understanding the formal support for the implementation of the participatory approach in sustainable urban development.

Moving from the policy analysis, qualitative inquiry with representatives of ten cities via open-ended written questionnaires with representatives of local authorities (mainly planning practitioners) in May 2022 is employed as a primary, and content analysis of local planning documents and cities' web portals as a secondary and complementary method of data collection and analysis. Questions were directed towards understanding practitioners' daily practice, i.e., if and how they perform participatory actions to actively engage different local action groups, investors, grass root organisations, professional associations and citizens in the formation of local urban and spatial plans and strategies [12]. Content analysis of the local plans, reports on conducted citizen participation and stakeholder involvement and strategies available at the local municipalities' web portals was performed during July and August 2022. The analysis considered qualitative content relating to the organised participatory processes in the formation and adoption of the plans/strategic documents.



The final phase of the research was participant observation and collection of planning professionals' narratives during the joint capacity-building workshop in the city of Kraljevo (Figure 1). This step was particularly important in order to obtain a direct account of the practitioners' work in a "face-to-face" communicative setting in which city representatives spoke about the potential and obstacles in implementing citizen participation and stakeholder engagement in their daily work. The described events relate to the experiences that planners face while dealing with the variety of interests in the formation process of urban and spatial plans, urban development strategies, and local development plans [13, 14].



*Figure 1. Capacity building workshop in Kraljevo, source: Authors' archive*

To assess participation capacities in selected case studies, qualitative findings obtained from the semi-open questionnaires with practitioners, results from content analysis of local planning documents at the web portals of the local authorities, as well as narratives from the workshop in Kraljevo were triangulated in each case study. The qualitative data, which was summarized, was presented based on the level of participation, namely through informing, consultation, and active participation, and exemplified on a descriptive chart (Figure 2). The levels of participation originate from the "ladder of citizen participation" from Sherry Arnstein, a conceptual model that illustrates the different levels of citizen involvement in decision-making processes. At the level of informing, citizens are provided with information about decisions made or planned, where the information flow is one-way, with little opportunity for feedback [15]. At the level of consultations, decision-makers and planning officials seek input from citizens through surveys or public inquiry [16]. However, there exists no requirement to act upon citizen input and recommendations, except for providing a written response. Finally, active participation in the planning process is intended to exemplify democratic decision-making, granting citizens and stakeholders the authority to advocate for their individual or shared interests [17].

### 3. RESULTS

Desk-based research of the recent policy framework supporting participatory planning in establishing new urban governance regimes revealed that Serbia recently adopted a cycle of documents that anchor participatory action at all levels of decision-making.

Citizen participation is traditionally recognized in the Planning and Construction law [18] through early public inquiry and public inquiry on the draft plan. With the opening of Chapter 22 – Regional policy and coordination of structural instruments [19] as part of the EU accession trajectory, and by signing the Additional Protocol to the European Charter of Local Self Government on the right to participate in the affairs of a local authority (2018) [20], Serbia has initiated the formation of the new cycle of planning documents in line with the EU Cohesion Policy for the period 2021-2027.

Planning systems law from 2018 [21] is considered a “pioneer” in harmonizing the new system of public policies with the EU. It states that “...participation of interested parties and target groups, citizen associations or business entities, civil society organizations, scientific-research, professional and other organizations, as well as state representatives” is obligatory in the process of adopting public policies (Article 34). The Regulation on the methodology of public policy governance, analysis of the effects of public policies and regulations and the content of individual public policy documents from 2019 [22], Local self-government law adopted from 2021 [23], and Gender equality law from 2021 [24] provide a framework for inclusion of citizens in decision-making processes on a broader level by supporting equal opportunities, rights and freedom to affect public policy.

Strategic objective 3 of the Sustainable urban development strategy of RS until 2030 [25] *Societal Well-being* advocates for increasing the level of transparency in the decision-making process in urban development through:

1. Raising the awareness of citizens and stakeholders about their right to be included in the decision-making process through informing, consultation and active participation methods,
2. Strengthening social responsibility and balancing public and private interests in decision-making processes,
3. Improvement of participation procedures through the implementation of e-participation, referendums, public-private dialogue, public consultations, citizen panels, citizen councils, citizen initiatives,
4. Evaluation and dissemination of good practice examples of participatory planning.

Content analysis of the policy framework suggests a considerably stronger role of public participation in decision-making processes after 2018. On the other hand, the results obtained from the analysis of semi-open questionnaires, local planning documents and web portals of cities suggest the need for expanding the framework for participatory action at the local level of decision-making (Figure 2).

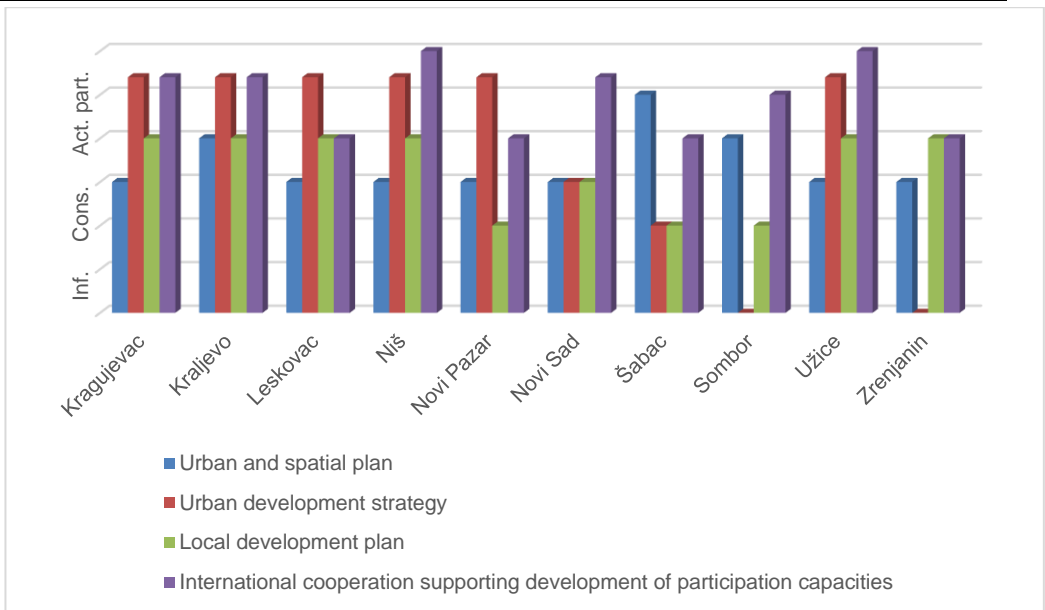


Figure 2. Descriptive chart representing qualitative data on public participation in local planning processes, source: Authors' elaboration of questionnaires' results and documents from the local administrations' web portals

The accumulated results from the semi-open questionnaire and analysis of plans, reports from the public inquiry and strategies at the cities' web portals point out that most of the cities have limited experience in facilitating active citizen participation. The engagement with citizens usually remains at the level of informing and consultations through traditional methods of early public inquiry and public inquiry. Cities of Kragujevac, Kraljevo, Niš and Užice showcase higher levels of active citizen participation that evolved through the processes of local sustainable and integrated urban development strategies formation. In contrast to traditional plans, strategy formation enabled greater flexibility in participation processes [26]. The flexibility is reflected in the testing of "alternative" participation methods that, among else, included: advertising the strategy document via info points in pedestrian areas of Kraljevo and through internet presentations at the web portal of the city administration (Integrated urban development strategy of the inner area of the city of Kraljevo); consultations with citizens and stakeholders through discussion groups or via internet consultations (Integrated urban development strategy of the city of Kragujevac); or, actively encouraging citizens to develop their ideas by drawing on the city map in the method called "Design workshop" (Integrated Urban Development Strategy for the Inner City of Užice). The findings are further "broken down" to understand how cities perform at each level of participation, further presented through exemplifying quotes:

At the level of *informing*, the results obtained from questionnaires and planning documents gathered from cities' web portals (specifically, reports derived from a public inquiry on the draft plan) reveal that all practitioners utilize the conventional approach of announcing planning initiatives in newspapers. Still, as one participant at the workshop in Kraljevo noted,

*"...this form of engagement does not reach diverse groups of citizens that might be directly affected by the planning solution"* (Practitioner 3, Workshop in Kraljevo).

Conversely, the endeavours of planning practitioners to better inform the public played a pivotal role in establishing a conducive environment for learning and experimentation, leading to open and inclusive participation processes. The cities of Sombor, Šabac, and Kraljevo exemplified the process of informing citizens and stakeholders about the planning initiative through semi-open questionnaires, showcasing instances of involving diverse local groups at the initial stages of the planning process. Planning professionals from the city of Sombor reached out to establish collaboration with elementary and high educational institutions, healthcare institutions, cultural centres, sports unions, and religious institutions in the formation of the Detailed Regulation Plan for the central area “Venac” in Sombor [27]. In addition, they engaged in communication with minorities (i.e., Roma population) and local citizen associations in the formation process of the Detailed Regulation Plan for “Bački Monoštor” – Roma population settlement [28]. Methods used in these cases are public forums and public presentations in sub-municipality units during the early public inquiry of planning processes. According to the local practitioner, these actions:

*“...contributed to accurate and timely inputs to the analysis of the current state in local settlements, further affecting the compliance with norms and standards for the planning of services of general economic interest”* (Practitioner 2, Questionnaire).

At the level of *consultations*, the representatives of the city of Užice spoke about an example where they attracted the participation of the wider population in the process of Local development plan formation by informing citizens via post:

*“...we initiated communication with the wider public via sending information about the local development plan in communal bills via post to almost 20.000 citizens”* (Practitioner 10, Workshop in Kraljevo).

According to the city representative, this initiative yielded over seven hundred suggestions and complaints during the later stages of plan formation, thereby enhancing the receptiveness of the proposed solutions by the public. At the level of *active participation*, the city of Kraljevo representative pointed out that engagement of the wider public and representatives of grassroots organizations in the process of local sustainable urban development strategy formation affected the selection of projects that were tailored according to the real needs of the local community. As they noted:

*“...participatory action with representatives of public enterprises, citizen associations, private investors and other stakeholders at each step of the strategy formation contributed better applicability and realistic scope of the strategy, that further resulted in wide public acceptability of the individual projects that evolved from the strategy [over 250 projects]”* (Practitioner 7, Workshop in Kraljevo).

The practitioner categorised this process as “active participation of citizens and stakeholders” due to the possibility to re-evaluate the strategic goals of the document within a collaborative setting.

## 4. DISCUSSION

A new cycle of policy in Serbia supported through the EU integration process evolves around the discourse on common values and public interest in the domains of sustainable development, social wellbeing, sustainable forms of commuting, climate change adaptation, green and low carbon development and economy,

environmental protection and disaster risk reduction poverty, and human rights. However, the adoption of the policy does not guarantee its implementation in practice [29]. Having that in mind, this research contributes to the identification of reflective actions through the application of different participatory methods in practice to enable discussion about real problems, common values and sustainability transition pathways [30]. This approach is important for examining the local context in Serbia, which is characterized by a lack of public dialogue, an ineffective response to the polarization of society, a weak fight against corruption and the general weakness of institutions [31].

The research results point out several critical points for developing participation practices in Serbia. Participation at the level of informing and consultations in a traditional form of the newspaper letter and public inquiries are insufficient generators of change [32]. The examples of “alternative” informing and consultations gathered through the research contributed to the understanding of existing capacities for longitudinal, integrated, sustainable and resilient urban development requires a re-evaluation of traditional relations and decision-making hierarchies towards more inclusive practices that rely on local knowledge of both experts and non-experts.

Active participation is intended to empower citizens and stakeholders, enabling them to creatively express their knowledge and experiences. The ultimate goal is for participants to cultivate a sense of personal responsibility toward implementing the adopted solutions, which is crucial in the process of sustainability transitions [33]. It should be noted that citizen participation and stakeholder involvement at the level of active participation in researched cases was predominantly incentivised and financially supported through the technical assistance of international donor organisations. The existence of technical and financial support contributed to better visibility of planning processes, the expertise of the staff facilitating participatory processes, as well as wider dissemination of participation results. Secondly, what is common to all of the analysed cases is that practitioners associate their participatory work with personal, besides professional efforts, recognising the complexity of plans’ thematic area and the necessity to involve diverse community groups.

## 5. CONCLUSION

Present-day discussions concerning urban matters at the EU level, exemplified by initiatives like the European Green Deal, emphasize the necessity of enhancing the participation capabilities of local communities and stakeholders. This emphasis aims to facilitate a smoother transition towards more efficient modes of mobility, the utilization of energy resources, social inclusion, green and low-carbon energy, and the development of a green economy in a bottom-up approach. Despite the notion that public participation is formally established as a normative basis that guarantees the rights of the public to participate in planning and development processes since the 1950s [34], a local culture of participation is still strongly anchored to the paternalistic regimes of state regulation and institutional setting. Local “culture of practice” in citizen participation and urban planning includes nowadays obstacles derived by wider processes of neoliberalization that imply more flexible procedures to accommodate market needs, frequent changes of urban legislation, deregulation, and privatisation to maximising investors’ profits. This trend leaves limited access to

real-life participation of all citizens, especially worsened during the Covid-19 pandemic [35, 36, 37]. From the socioeconomic and environmental point of view, citizens too often remain unheard of in urban development processes even before the pandemic. There is the need to include citizens in planning processes but within a more solid new urban governance strategy.

The potential of Serbian cities to follow up the sustainability transition may further rely on the planning practitioners' experience in "working under uncertainty" under current conditions [38]. The widened policy framework supporting public participation provides a base for further empirical research and testing of innovation through active participation to seek new opportunities enabling integrated and sustainable urban development.

## ACKNOWLEDGMENTS

This research was supported by the Ministry of Science, Technological Development and Innovation of the Republic of Serbia (Grant No. 451-03-47/2023-01/200006) and World Bank Group and SECO project "Technical assistance: Strengthening capacities of local self-governments in Serbia towards low-carbon and resilient urban development investments", Selection: #1275674.

## REFERENCES

- [1] Tasan-Kok Tuna: **Entrepreneurial Governance: Challenges of Large-Scale Property-Led Urban Regeneration Projects**. *Tijdschrift voor Economische en Sociale Geografie*, Vol. 101, No. 2, 126-149, 2010.
- [2] European Commission: **EU Cohesion Policy 2021-2027**, 2021. [https://cohesiondata.ec.europa.eu/cohesion\\_overview/21-27](https://cohesiondata.ec.europa.eu/cohesion_overview/21-27) (11.6.2023)
- [3] Jessop Bob: The rise of governance and the risks of failure: the case of economic development. *International Social Science Journal*, Vol. 155, 29-45, 1998.
- [4] Cars Göran, Healey Patsy, Madanipour Ali, De Magalhaes Claudio: **Urban Governance, Institutional Capacity and Social Milieux**. *Ashgate*, Aldershot, Hants, 2017.
- [5] Hyden Goran: **Making the state responsive: rethinking governance theory and practice**. Making the state responsive: Experience with democratic governance assessments. *UNDP*, New York, 5-28, 2011.
- [6] Lissandrello Enza, Morelli Nicola, Schillaci Domenico, Di Dio Salvatore: **Urban Innovation Through Co-design Scenarios. Lessons from Palermo**. *The Interplay of Data, Technology, Place and People for Smart Learning*, Aalborg University, Denmark, 110-122, 2018.
- [7] Čolić Ratka, Milić Đorđe, Petić Jasna, Čolić Nataša: **Institutional capacity development within the national urban policy formation process – Participants' views**. *Environment and Planning C Politics and Space*, Vol. 40, No. 1, 69-89, 2021.
- [8] Government of the Republic of Serbia: **Sustainable Urban Development Strategy of Serbia until 2030**, "Official Gazette of the Republic of Serbia", No. 47, 2019.
- [9] Pierre John: **Comparative urban governance: Uncovering complex causalities**. *Urban Affairs Review*, Vol. 40, No. 4, 446-462, 2005.

- [10] Čolić Nataša, Dželebdžić Omiljena: Beyond formality: A contribution towards revising the participatory planning practice in Serbia. *Spatium International Review*, No. 39, 17-25, 2018.
- [11] Bryman Alan: **Social research methods**. Oxford University Press, Oxford, 2012.
- [12] Čolić Nataša, Dželebdžić Omiljena: Beyond formality: A contribution towards revising the participatory planning practice in Serbia. *Spatium International Review*, No. 39, 17-25, 2018.
- [13] Flyvbjerg Bent, Landman Todd, Sanford Schram: **Real Social Science: Applied Phronesis**. Cambridge University Press, New York, 2012.
- [14] Čolić Nataša, Nedović-Budić Zorica: **Public Interest as a Basis for Planning Standards in Urban Development: State-Socialist and Post-socialist Cases in Serbia**. *Journal of Planning Education and Research*, 2021. [10.1177/0739456X211051421](https://doi.org/10.1177/0739456X211051421) (12.6.2023)
- [15] Arnstein Sherry R.: (1969) **A Ladder Of Citizen Participation**. *Journal of the American Institute of Planners*, Vol. 35, No. 4, 216-224, 1969.
- [16] Čolić Nataša, Dželebdžić Omiljena: Beyond formality: A contribution towards revising the participatory planning practice in Serbia. *Spatium International Review*, No. 39, 17-25, 2018.
- [17] Maier Karel (2001) **Citizen Participation in Planning: Climbing a Ladder?**. *European Planning Studies*, Vol. 9, No. 6, 707-719, 2001.
- [18] Government of the Republic of Serbia: **Planning and Construction Law**, "Official Gazette of the Republic of Serbia", No. 72/2009, 81/2009, 64/2010, 24/2011, 121/2012, 42/2013, 50/2013, 98/2013, 132/2014, 145/2014, 83/2018, 31/2019, 37/2019, 9/2020 and 52/2021.
- [19] <https://www.mei.gov.rs/eng/news/908/more/w/0/action-plan-for-chapter-22-regional-policy-and-coordination-of-structural-instruments-adopted/> (11.6.2023)
- [20] Government of the Republic of Serbia: Additional Protocol to the European Charter of Local Self-Government on the right to participate in the affairs of a local authority, 2018. [http://www.parlament.gov.rs/upload/archive/files/cir/pdf/predlozi\\_zakona/2169-18.pdf](http://www.parlament.gov.rs/upload/archive/files/cir/pdf/predlozi_zakona/2169-18.pdf) (11.6.2023)
- [21] Government of the Republic of Serbia: **Planning Systems Law**, "Official Gazette of the Republic of Serbia", No. 30, 2018. <https://www.pravno-informacioni-sistem.rs/SlGlasnikPortal/eli/rep/sgrs/skupstina/zakon/2018/30/1/reg> (11.6.2023)
- [22] Government of the Republic of Serbia: **Local Self-government Law**, "Official Gazette of the Republic of Serbia", No. 129/2007, 83/2014, 101/2016, 47/2018, 111/2021. <https://www.pravno-informacioni-sistem.rs/SlGlasnikPortal/eli/rep/sgrs/skupstina/zakon/2007/129/2/reg> (11.6.2023)
- [23] Government of the Republic of Serbia: Regulation on the methodology of public policy governance, analysis of the effects of public policies and regulations and the content of individual public policy documents, 2019. <https://rsjp.gov.rs/wp-content/uploads/Regulation-on-the-methodology-of-public-policy-management-with-Annex.pdf> (11.6.2023)
- [24] Government of the Republic of Serbia: **Gender Equality Law**, "Official Gazette of the Republic of Serbia", No. 52/2021.
- [25] Government of the Republic of Serbia: **Sustainable Urban Development Strategy of Serbia until 2030**, "Official Gazette of the Republic of Serbia", No. 47, 2019.
- [26] Čolić Ratka, Mojović Đorđe, Petković Mladen and Čolić Nataša: **Guide for Participation in Urban Development Planning**, AMBERO, Belgrade, 2013.
- [27] Detailed Regulation Plan for the central area "Venac" in Sombor, "Official Gazette of the City of Sombor", No. 3, 2009. <https://drive.google.com/drive/folders/1yZx-HBuNXBGZ4rq2qD4QgE9tWA3cuGzn> (12.6.2023)

- [28] Detailed Regulation Plan for “Bački Monoštor” – Roma population settlement, “Official Gazette of the City of Sombor”, No. 8, 2015.  
<https://drive.google.com/drive/folders/11Old63jMNnmJGa6oefYs1oHb3g3Lun4Y>  
(12.6.2023)
- [29] Čolić Ratka: Integrated Urban Development Strategy as an Instrument for Supporting Urban Governance. *Serbian Architectural Journal SAJ*, Vol.7, No.3, 317-342, 2015.
- [30] Čolić Ratka, Milovanović Rodić Danijela, Fokdal Josephine: **To what extent can collaborative platforms in urban planning education enhance transformative learning outside of academia?** *International Journal of Sustainability in Higher Education*, Vol. 27, No. 7, 2023.
- [31] EC Directorate-General for Neighbourhood and Enlargement Negotiations: **Serbia Report 2021**, 2021. [https://ec.europa.eu/neighbourhood-enlargement/serbia-report-2021\\_en](https://ec.europa.eu/neighbourhood-enlargement/serbia-report-2021_en) (12.6.2023)
- [32] Lukić Milica: **Stavovi građana i građanki o mogućnostima učešća u procesu prostornog i urbanističkog planiranja u Srbiji**, Zbornik radova Jedanaestog naučno-stručnog skupa sa međunarodnim učešćem “Planska i normativna zaštita prostora i životne sredine”, Vršac, 321-327, 2021.
- [33] Lamborgne Pia, Ekkil Epongue, Wendel Jochen, Pierce Andrea, Heyder Monika, Suchomska Joanna, Nichersu Iulian, Balaican Dragos, Ślebioda Krzysztof, Wróblewski Michał, Wojciech Goszczynski: **Urban Living Labs: how to enable inclusive transdisciplinary research?** *Urban Transformations*, Vol. 3, No. 11, 2021.
- [34] Government of the Federative Social Republic of Yugoslavia: **Basic Resolution on General Urban Plan**, “Official Gazette of the FNRJ”, No. 78/49, 1949.
- [35] Pantić Marijana, Čolić Nataša: **Digital Participation Framework for Mountain Areas in Serbia**. *Transylvanian Review of Administrative Sciences*, Vol. 19, 2023.
- [36] Nenković-Riznić Marina, Danilović-Hrستیć Nataša, Simonović-Alfirević Sanja: New Technologies in the Function of Participatory and Educational Processes in Urban Planning – Challenges of COVID-19 and the Future of Dialogue, *Book of Abstracts & Proceedings of 10th International Conference “On Architecture — Philosophy of Architecture” STRAND*, Belgrade, 287-292, 2022.
- [37] Nenković-Riznić Marina, Simonović-Alfirević Sanja: **Participatory planning in the post-pandemic period – towards new stakeholder communication**, *Book of proceedings from IRASA International Scientific Conference SCIENCE, EDUCATION, TECHNOLOGY AND INNOVATION- SETI IV 2022*, Belgrade, 393-400, 2022.
- [38] Čolić Nataša, Dželebdžić Omiljena, Čolić Ratka: **Building on Recent Experiences and Participatory Planning in Serbia: Toward a New Normal**. The ‘New Normal’ in Planning, Governance and Participation: Transforming Urban Governance in a Post-Pandemic World, *Springer*, 2023.



# OCCUPATIONAL SAFETY AND HEALTH IN CONSTRUCTION INDUSTRY – CHALLENGES OF MODERN LABOR LEGISLATION AND PRACTICE

Aleksandra Ilić Petković<sup>1</sup>, Ivan Mijailović<sup>2</sup>

## Abstract

*In the Republic of Serbia, construction is one of the industries with the most frequent injuries at work, which often result in death. Statistical data of the Labor Inspectorate and the Occupational Safety and Health Administration have unequivocally confirmed this fact over the years. Nowadays, construction industry is in great expansion and a large number of able-bodied people are currently employed in this industry, which is why special attention is paid to the occupational safety and health of this category of employees.*

*The Proposal for the Law on Occupational Safety and Health, which regulates safety and health at work in construction industry, is in the procedure of the National Assembly of the Republic of Serbia. Therefore, there are two challenges to be considered - the application of existing legal solutions and their amendment. The current Law on Occupational Safety and Health has been in force since 2005. This period is sufficient for the critical observation of legal regulations and proposal of new ones.*

*The paper analyzes the existing legal solutions on occupational safety and health in the current Law and accompanying by-laws. Also, certain solutions are proposed for the improvement of legal regulations in the field of occupational safety and health in construction industry.*

**Key words:** *construction, occupational safety and health, legal regulations, law*

---

<sup>1</sup> Ph.D, Associate Professor, University of Niš, Faculty of Occupational Safety in Niš, [aleksandra.ilic@znrfak.ni.ac.rs](mailto:aleksandra.ilic@znrfak.ni.ac.rs)

<sup>2</sup> Ph.D, Associate Professor, University of Niš, Faculty of Occupational Safety in Niš, [ivan.mijailovic@znrfak.ni.ac.rs](mailto:ivan.mijailovic@znrfak.ni.ac.rs)

## 1. INTRODUCTION

The right to safe and healthy working conditions is one of the oldest human rights (second generation human rights) proclaimed in the middle of the 20th century by the United Nations in the Covenant on Economic, Social and Cultural Rights from 1966 [1]. Since then, the content of this right has been increased and nowadays it represents the basis of occupational safety for all categories of employees in all industries. However, research shows that there are certain industries where injuries at work occur more often than in others, or they are more serious by nature or end in death. In the Republic of Serbia, one of such industries is construction.

There is a number of issues in the field of occupational safety and health in construction that are not common in other industries, which is recognized by the legislature of Serbia. The reports of the relevant institutions (Occupational Safety and Health Administration and Labor Inspectorate) indicate that special attention should be paid to the construction industry when creating policies and regulations in the field of occupational safety. Thus, based on the Report on the work of the Labor Inspectorate for 2017, labor inspectors performed 919 inspections in 2017 regarding fatal injuries at work, serious injuries with fatal outcome, serious injuries, collective and minor injuries at work. Out of 23 inspections regarding fatal injuries at work, as many as 9 (39%) occurred in the construction industry. Regarding injuries with a fatal outcome, out of 16 recorded, 6 (37%) occurred during construction works. Out of 870 serious injuries at work, 116 occurred on construction sites [2]. A similar trend continued in the following years [3].

In the legal system of the Republic of Serbia, there is a whole series of documents regulating occupational safety and health in construction. Compared to the Law from 2005, the recently adopted Law on Occupational Safety and Health [4] contains a greater number of provisions regulating construction industry, which indicates the importance of preventing injuries at work in this field. After this law was adopted, the procedure of adopting a new Decree on Occupational Safety and Health at Temporary or Mobile Construction Sites was initiated. The current Decree was adopted in 2009.

In this paper, the legal framework of occupational safety and health in the construction industry in the Republic of Serbia was analyzed with a special emphasis on new legal solutions in the new Law on Occupational Safety and Health. Also, by analyzing the problems in the application of regulations from this field in practice, certain legal solutions were proposed that would improve the system of safety and health at work and which could be implemented in new by-laws that will be adopted on the basis of the Law. Adopting a new law is always an opportunity to correct all the shortcomings of previous laws and propose legal solutions that could give better results. Regarding occupational safety, this means a reduction in the number of injuries at work in general, including construction. After the adoption of the new law, the next step is to synchronize by-laws with the law, which has already started. This is also a good opportunity to solve the problems observed in practice.

## **2. CURRENT ISSUES IN THE FIELD OF OCCUPATIONAL SAFETY AND HEALTH IN CONSTRUCTION INDUSTRY**

Based on the reports of the Occupational Safety and Health Administration and the Labor Inspectorate from previous years, certain trends in the occurrence of occupational injuries can be observed. Therefore, bearing in mind the work environment in which the injury occurred, the source and cause of the injury, etc., it is clear that construction is an industry in which work-related injuries often occur, most often with a fatal outcome.

According to the data of the Occupational Safety and Health Administration from 2021 [2] and considering the working environment where the injuries occurred, in construction industry the number of injuries is considerable. Thus, 9 work-related injuries occurred at a construction site, open-pit quarry and open-pit mine. There were 62 work-related injuries on construction sites during the construction of buildings and 20 injuries on construction sites during the demolition, remodeling and maintenance of buildings. Three injuries occurred on underground construction sites and 31 work-related injuries occurred in an open-pit quarry, open-pit mine, excavation and trench (including open-pit mines and quarries).

Taking into account the work process, in 2021 there were 8 injuries during excavation, 41 injuries during the construction of buildings, 15 injuries during the construction of infrastructure, roads, bridges, dams and ports, 15 injuries during remodeling, repair, expansion and maintenance of buildings and 1 injury when demolishing all types of buildings [2].

Regarding the specific physical activity during which injuries at work occurred, in 2021 there were 68 injuries during the activities of manual holding, grasping, clamping and placing - at a horizontal level, 24 during the activities of tying, joining, tearing, untying, clamping, unscrewing, screwing and turning, 25 injuries during the activity of fixing, hanging, lifting and placing - at the vertical level and 2 injuries in the activity of throwing and swinging.

When driving a means of transport or handling equipment - mobile and mechanized, 34 injuries at work were recorded. When driving a means of transport or handling equipment - mobile and non-mechanized there were 13 injuries, as well as 22 injuries of passengers in a means of transport. These activities can take place, among others, in the construction sector.

Considering the source of the injury, 46 injuries occurred in buildings, structures and surfaces - at ground level (closed or open, immovable or movable, temporary or not). In building and structure components - doors, walls, partitions, obstacles (windows, etc.), there were 29 injuries. In buildings, structures and surfaces - above ground level (closed or open, immovable or movable, temporary or not), there were 14 injuries. In building components above ground level - immovable (roofs, terraces, doors, windows and staircases) 58 injuries occurred. In buildings and surfaces above ground level - stationary (including walkways, fixed ladders and pylons) 14 injuries occurred. In buildings and surfaces above ground level - mobile (including mobile ladders and lifting platforms) there were 26 injuries. In buildings above ground level - temporary (including temporary scaffolding) 6 injuries occurred. In buildings above ground level - floating (including drilling rigs and scaffolding on barges) there was 1 injury. Also, in buildings, structures and surfaces - below ground level (closed or open) in 2021, there were 4 work-related injuries. In excavations, trenches, wells,

openings, landslides and garage pits 16 injuries occurred. On underground surfaces and in tunnels 7 injuries occurred. In the systems for supply and distribution of materials and pipe network - fixed - for gas, air, liquid, solid material, including bunkers, there were 6 injuries, etc.[2].

The report of Occupational Safety and Health Administration for the year 2022 records similar data. In the past year, the largest number of injuries at work was recorded in the processing industry, transport and storage, and construction is at the very top [5]. Based on the review of occupational injuries classified according to the work environment in which they occurred, it can be observed that construction is again predominant - industrial location (40.25%), construction site, open quarry and open mine (8.51%), followed by the agricultural zone, livestock breeding zone, fish breeding zone and forest zone (3.54%), etc. The analysis of occupational injuries classified according to the work process identifies movement, including driving a means of transport (14.02%), production, manufacturing and processing (12.78%) and maintenance, repair, installation and adjustment (7.10%) as the riskiest stages in the work process. These activities are related to work processes in construction.

The analysis of the data provided by the Labor Inspectorate on the number of fatal occupational injuries in construction industry for the period 2013-2016 [6] shows that the greatest number of injuries occurred during a fall from a height (58.7%), earth filling (17.5%) and electric shock (7.9%) [7].

### **3. LEGAL FRAMEWORK AND PERSPECTIVES FOR THE IMPROVEMENT OF LEGISLATION**

The Constitution, as the highest legal act in the Republic of Serbia, in Article 60 stipulates that everyone has the right to the necessary protection at work and that no one can renounce these rights [8]. These provisions are further elaborated by the Labor Law and the Law on Occupational Safety and accompanying by-laws (several dozens of decrees and regulations).

The Law on Occupational Safety and Health from 2023 contains a large number of provisions dedicated to occupational safety in construction industry, which is more than the previous law from 2005 [4]. At the very beginning there are the definitions of some terms that were not defined by the previous law, and some terms are defined differently. Thus, the work site is an outdoor area where work is performed in accordance with the elaboration on the organization and execution of works and the regulations on occupational safety and health. Work in depth is work in excavations deeper than one meter or embankments higher than one meter. Work at a height is any work that an employee performs using supports at a height of two meters or more from a solid surface, where the work area is not protected from falling from a height.

Now the legislator recognizes works on the construction site, i.e. work site, as well as emergency works. An employer who performs works on the construction of a building in accordance with the regulations on occupational safety and health on temporary or mobile construction sites, as well as an employer who performs works on the work site in accordance with the regulations on occupational safety and health, is obliged to submit a report on the commencement of works to the competent labor inspection at least eight days before they start. The employer is obliged to make a report on the construction site layout, if the works last longer than

three days continuously, and a report on the work site layout, which is to be submitted to the competent labor inspectorate along with the report on the commencement of works, at least eight days in advance. The employer is obliged to ensure, maintain and implement safety and health measures at the construction site, i.e. work site, in accordance with the report and the Risk Assessment Act. In the case of emergency works on infrastructure facilities for the purpose of eliminating defects or a sudden and uncontrolled event on the facility, the employer is obliged to report the emergency works to the competent labor inspectorate immediately, from the time of occurrence, verbally and in writing, as well as to implement measures during emergency works and rehabilitation in accordance with the Risk Assessment Act. In both cases, the application can be submitted online [4].

When two or more employers share a work space while performing work, i.e. when employees of several organizations simultaneously perform work in the same work space, employers are obliged to cooperate in the implementation of prescribed measures for the safety and health of employees. Employers are obliged to coordinate activities related to the implementation of measures to eliminate the risk of injury or damage to the health of employees, as well as inform each other and their employees and/or employee representatives about these risks and measures to eliminate them. Employers determine the way of cooperation in a written agreement, concluded before the commencement of works.

The employer is obliged to take measures to prevent access to the facility area that is used as a working and support area, including the facility in the open space, by persons and vehicles whose presence is not justified.

Also, with every change in the work process, the employer is obliged to adjust the equipment to that work process before the commencement of works.

Before the commencement of works at a height, in depth, in a confined space, in a space with potentially explosive atmospheres, on an energy facility, when using dangerous chemical substances and in zones where there is a serious, unavoidable or immediate danger or harm that may endanger the health of the employee, the employer is also obliged to provide a work permit.

Provisions on personal protective equipment remained largely unchanged. The employer is obliged to provide work equipment and personal protective equipment in proper condition and on which the prescribed measures for occupational safety and health have been applied and ensure the control of their use in accordance with the purpose. The employer is obliged to conduct the training in the proper use of personal protective equipment. The employer may provide work equipment and personal protective equipment to employees only if the equipment complies with the prescribed technical requirements, if its compliance has been assessed according to the prescribed procedure, if it is labeled in accordance with the regulations and if it is accompanied by the prescribed documents on compliance and other prescribed documentation.

When occupational safety and health measures are not prescribed due to the introduction of new technology, the employer applies generally recognized measures to ensure the safety and health of employees until the adoption of appropriate regulations. A generally recognized measure is a measure that can eliminate the danger at work or reduce harm to the employee's health, to the extent that is reasonably feasible [4]. This is a new provision which now gives space to

employers and their experts for occupational safety and health to legalize some situations that were not recognized before.

The mentioned law is accompanied by numerous by-laws - Regulation on Occupational Safety and Health on Temporary or Mobile Construction Sites [8], Rulebook on Occupational Safety during Construction Works [9], Rulebook on the Content of the Study on the Construction Site Layout [10], etc. This group of secondary legal acts can also include general acts such as the Rulebook on Preventive Measures for Safe and Healthy Work When Using Means and Equipment for Personal Protection at Work [11], the Rulebook on Personal Protective Equipment [12] etc. because they are also applied in occupational safety in construction.

#### **4. CONCLUSION**

Today, construction workers are exposed to risks of various types and intensities [13]. Construction is in great expansion and represents one of the industries with the highest number of employees. It is also associated with a large number of injuries at work [14]. Expert analyses have shown that the majority of injuries at work (individual and collective, with fatal consequences, serious and minor injuries) in the construction industry are caused by the non-application of the basic principles of work execution, deviation from the prescribed and established work process, work at an unsecured height, working along the unsecured edge of the object from which it is possible to fall into the surrounding area, working on improperly mounted scaffolding, working in improperly secured excavations, not using prescribed tools and equipment for personal protection (primarily a protective helmet and protective belt), lack of training in safe and healthy work, carelessness and insufficient concentration of employees at work, hiring a significant number of untrained persons etc. [15].

The prerequisite for ensuring the conditions for safe and healthy work are regulations that define this problem, measures that the legislator and the employer will apply in order to implement the policy of protecting employees at work, awareness of their necessity and training in safe and healthy work. Defining the legal framework of occupational safety and health in construction, as well as defining the protective measures by the employer, that is, occupational safety and health experts, is specific compared to other industries and it requires a special and comprehensive approach. In order to create adequate legal regulations for the protection of employees in the construction industry, the first step is to identify problems in the application of valid regulations, and then change those regulations and monitor their implementation.

As the new Law on Occupational Safety and Health has been adopted recently, it is assumed that it additionally regulates certain aspects which are proven to be an issue, such as construction. After the adoption of the new law, the logical sequence of steps should be the review of the existing by-laws, where there is also plenty of room for improvement in the field of construction [16]. Along with the adoption of new by-laws, the Occupational Safety and Health Strategy for the upcoming period is being prepared. Its goals are defined in such a way that they should contribute to the reduction of injuries at work in general, including in construction, and especially the reduction of fatal injuries at work.

Finally, it should be taken into consideration that any legal regulation, no matter how high-quality and comprehensive it is, requires effective application in practice. For this reason, it is highly desirable to intensify the work inspection supervision at construction sites. It should be emphasized that the goal of the inspection supervision is not only to punish violators of certain regulations, but also to achieve closer cooperation with employers and employees and their better understanding of the regulations on occupational safety and health in construction. In this way, the preventive role of the inspection supervision would be realized, which would contribute to the reduction of unfavorable statistics regarding the number of injuries at work in the construction industry.

## ACKNOWLEDGMENTS

This research was funded by the Ministry of Science, Technological Development and Innovation of the Republic of Serbia, Contract on the realization and financing of scientific research work of the scientific research organization in 2023 number 451-03-47/2023-01/ 200148.

## REFERENCES

- [1] **International Covenant on Economic, Social and Cultural Rights**, <https://www.ohchr.org/en/instruments-mechanisms/instruments/international-covenant-economic-social-and-cultural-rights> (15.5.2023)
- [2] **Report of the Occupational Safety and Health Administration for the Year 2021**, <https://www.minrzs.gov.rs/sr/dokumenti/izvestaji/uprava-za-bezbednost-i-zdravlje-na-radu-0> (20.5.2023)
- [3] Mijailović Ivan, Ilić Petković Aleksandra: **Protection of employees in construction industry – in anticipation of the new Law on occupational safety and health**. The 19th International Conference “Man and Working Environment”, Niš, 111-114, 2022.
- [4] **Law on Occupational Safety and Health**, Official Gazette of the Republic of Serbia, No. 35/2023
- [5] **Report of the Occupational Safety and Health Administration for the Year 2022**, <https://www.minrzs.gov.rs/sites/default/files/2023-03/%D0%98%D0%B7%D0%B2%D0%B5%D1%88%D1%82%D0%B0%D1%98%20%D0%BE%20%D1%80%D0%B0%D0%B4%D1%83%20%D0%B7%D0%B0%202022.%20%D0%B3%D0%BE%D0%B4%D0%B8%D0%BD%D1%83.pdf> (10.5.2023)
- [6] **Report on work of the Labor Inspectorate for the year 2017**, Ministry of Labour, Employment, Veteran and Social Affairs Competitiveness and Jobs Project, Belgrade, 2018.
- [7] Bulat Petar, Hirose Kenichi, Protić Jovan: **Occupational Safety and Health in Construction in Serbia**. ILO, Geneva 2018.
- [8] **Constitution of the Republic of Serbia**, Official Gazette of the Republic of Serbia, No. 98/2006.
- [9] Regulation on Occupational Safety and Health at Temporary and Mobile Construction Sites, Official Gazette of the Republic of Serbia, No. 14/2009, 95/2010, 98/2018.
- [10] **Rulebook on Occupational Safety During Construction Works**, Official Gazette of the Republic of Serbia, No. 53/1997.

- [11] Rulebook on the Content of the Report on Construction Site Development, Official Gazette of the Republic of Serbia, No. 102/2015.
- [12] Rulebook on Preventive Measures for Safe and Healthy Work When Using Means and Equipment for Personal Protection at Work, Official Gazette of the Republic of Serbia, No. 92/2008, 101/2018.
- [13] **Rulebook on Personal Protective Equipment**, Official Gazette of the Republic of Serbia, No. 23/2020.
- [14] Petrović Miloš, Andjelić Kristina, Prvulović Petrović Marina: **Safety of Workers carrying out construction works and use of machinery**. *Military Technical Courier*, Vol. 62, No. 2, 151-165, 2014.
- [15] Mučenski Vladimir et al.: **Analysis of Falls to the Level Below in Construction Industry of Serbia**. Proceedings from the Conference "50 Years of Higher Education, Science and Research in Occupational Safety Engineering", Niš, 237-240, 2018.
- [16] Ilić Petković, Aleksandra, Mijailović Ivan: **Practical Challenges in The Application of Occupational Safety Regulations in Civil Engineering**. The 8th International Professional and Scientific Conference "Occupational Safety and Health", Zadar, Croatia, 21-24, 2022.



## DEFLECTIONS OF BARREL VAULT SHAPED MEMBRANE MODEL UNDER EXTERNAL LOADS

Vuk Milošević<sup>1</sup>, Dragan Kostić<sup>2</sup>, Miomir Vasov<sup>3</sup>, Dušan Randelović<sup>4</sup>, Janusz Marchwiński<sup>5</sup>

### Abstract

*Synergy of architecture and engineering is perhaps the most visible with tensile membrane structures. These structures combine the architectural qualities and structural performance in order to create unique buildings. At the same time, they are well known for their large deflections under external loads. This is especially noticeable when compared to deflections of concrete or steel structures under the same load. Deflections of tensile membranes have recently been a topic of several researches. This research extends the existing body of knowledge in the field. The novelty of the research is in the application of a new load type and a new variable parameter. The aim of the research is to obtain results so that this data can be compared to the conclusions previously obtained on different membrane geometries. Barrel vault shaped numerical model of the membrane with variable height is tested. Prestress of the membrane and material properties are varied. Maximal deflections under concentrated load, wind load and snow load are recorded and discussed.*

**Key words:** *Tensile Membrane Structures, External Loads, Barrel Vault Shape, Deflections, Numerical Model*

---

<sup>1</sup> Dr., Associate Professor, Faculty of Civil Engineering and Architecture, University of Niš, vukamer@yahoo.com

<sup>2</sup> Dr., Professor, Faculty of Civil Engineering and Architecture, University of Niš, dragan.kostic@gaf.ni.ac.rs

<sup>3</sup> Dr., Professor, Faculty of Civil Engineering and Architecture, University of Niš, miomir.vasov@gaf.ni.ac.rs

<sup>4</sup> Dr., Assistant Professor, Faculty of Civil Engineering and Architecture, University of Niš, dusan.randjelovic@gaf.ni.ac.rs

<sup>5</sup> Dr., Professor, Faculty of Architecture, University of Ecology and Management in Warsaw, j.marchwinski@wp.pl

## 1. INTRODUCTION

Tensile membrane structures present a perfect example of synergy of architecture and engineering. To design tensile membranes, structural limitations of membrane material are cleverly used to create visually pleasant and atypical buildings. Extraordinary forms of tensile membranes coupled with their minimalistic appearance result in appealing structures that connect architectural qualities and structural performance.

This research focuses on deflections of tensile membranes. The properties of membrane material are very specific compared to other building materials and, therefore, the structural response of these structures is also very specific. Due to the lack of bending stiffness, membranes respond to external loads with large changes of geometry. This, in addition, results in significant changes of tensile forces in the structure. The numerical experiment presented in this paper is conducted on barrel vault shaped models, as one of the most frequent types of membrane structures. Several variables were applied to the models. Numerical models were loaded with external loads. The results are presented and discussed for different variables and loads. The aim of the research is to obtain deflection results for barrel vault shaped membranes, so that they can be compared to other membrane geometries analyzed previously, in order to reach general conclusions and form recommendations about membrane deflections that are currently missing.

The scope of this research belongs to several subfields of exploring tensile membranes. These are the effects of external loads, deflections, membrane properties and design of architectural membranes. The research presented in this paper relies mostly on the paper [1] for structuring the methodology of the research. It explores the significance of form and material properties in designing tensile fabric structures. Other papers also explore the properties of membrane material [2-4]. Deflections of tensile membranes were the topic of several researches [5-8]. Results for static [9] and dynamic loads [10] are given in published literature. Currently, recommendations about designing of tensile membrane structures are given in [11-13].

The research presented in this paper introduces several novelties compared to the published body of knowledge. As previously stated, the paper [1] was used as a base for this research. In comparison to this research, a new type of load was added. In addition to the snow load and the wind load, a concentrated load was defined and applied to the models. Also, in the published paper [1], two variables are considered, model height and the elastic modulus of the membrane. Here, a third variable, the prestress intensity of the membrane, is added. Compared to the paper [14] that has the same methodological setup, the focus of the research is different. While in that research the same models are analyzed in order to investigate the membrane forces, here the membrane deflections are explored. In the researches [5-7], the deflections of tensile membranes are analyzed, but it was done on hyperbolic paraboloid shaped models, while here the barrel vault shaped models are tested.

## 2. METHODOLOGY

The first step in the numerical experiment was to define the parameters of the numerical model of tensile membrane structure. In the second step, some of the

parameters were selected to be analyzed and are therefore modified from constant to variable. The analyzed values of these parameters were defined in the third step. The fourth step was focused on selecting the loads and their values. In the fifth step the structural analysis was conducted in software Sofistik and the deflection results were recorded. The final step of the research was devoted to the discussion of the obtained results.

Constant parameters were replicated according to the third defined membrane model of the research [1]. The base of the model was set to have a square shape with the side length of 10 m. The general shape of the membrane was defined as barrel vault by having two opposite edges straight and the other two arched with arches in vertical plane. All four edges are rigid and fixed.

Three variable parameters were defined. In addition to the material properties and model height, that were varied in paper [1], here also the prestress of the membrane was altered. This parameter was added to variables since this is one of the decisions that designers of the structure need to make and currently there is insufficient scientific data on this topic. While in the cited research only the elastic modulus of the membrane material was varied, here the elastic and shear modulus were proportionately changed in order to model the membrane more realistically.

Contrary to the research [1], the height of 0 m was not considered here, as the flat horizontal membranes are not applicable. Instead, the height of 1 m was selected as the lowest one. For the greatest height, the value of 5 m was selected, as it is the half of the side length and gives a half-circle membrane edge. For intermediate values a step of 1 m was selected. Thus, the analyzed values are 1, 2, 3, 4 and 5 m. For the elastic modulus of membrane material values from [1] are taken, but the values for shear modulus are linked to them. So the analyzed values are 250 and 12.5, 600 and 30, 1000 and 50, and 2000 and 100 kN/m for elastic and shear modulus respectively. These properties are named membrane properties 1, 2, 3 and 4 respectively. The Poisson's ratio was fixed at 0.4. The membrane prestress values are taken to be the same in warp and weft direction. Selected values for analysis are 1, 2, 3, 4 and 5 kN/m in both directions. These values are selected as applicable for the analyzed models, although they can also be larger.

Two of the analyzed loads are the same as in the research [1]. These are the wind and snow load. The wind load has a value of 1 kN/m<sup>2</sup> across the membrane and is perpendicular to the membrane surface with the upper direction. The snow load has a value of 0.6 kN/m<sup>2</sup> across the entire membrane with a vertical downwards direction. Both loads are applied as static. A third type of load was added to this research. This is the concentrated load, whose significance has been recently explored [6]. It was added as a static load of 1 kN evenly spread across the 0.1x0.1 m area at the center of the membrane. The load represents a man standing on the membrane and has a vertical downward direction.

The results of the research are presented in section 3 and the discussion is given in section 4. The representation of the model with the height of 3 m is given in Figure 1.

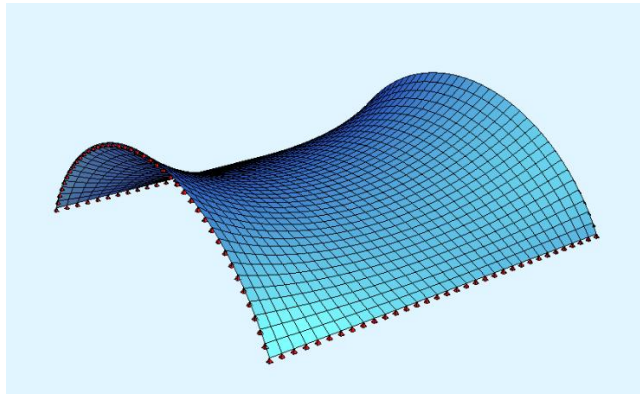


Figure 1. Model of the tensile membrane with the height of 3 m

### 3. RESULTS

The results of the numerical experiment are given in this section. With membrane deflections it is generally important to track the value of maximal deflections and the position of maximal deflections. The first presented results are from a model with the 3 m height, 3kN/m prestress and material properties 2. Figure 2 shows the deflections of the whole membrane under the concentrated load. Figure 3 shows the deflections of the same model under the snow load and Figure 4 under the wind load.

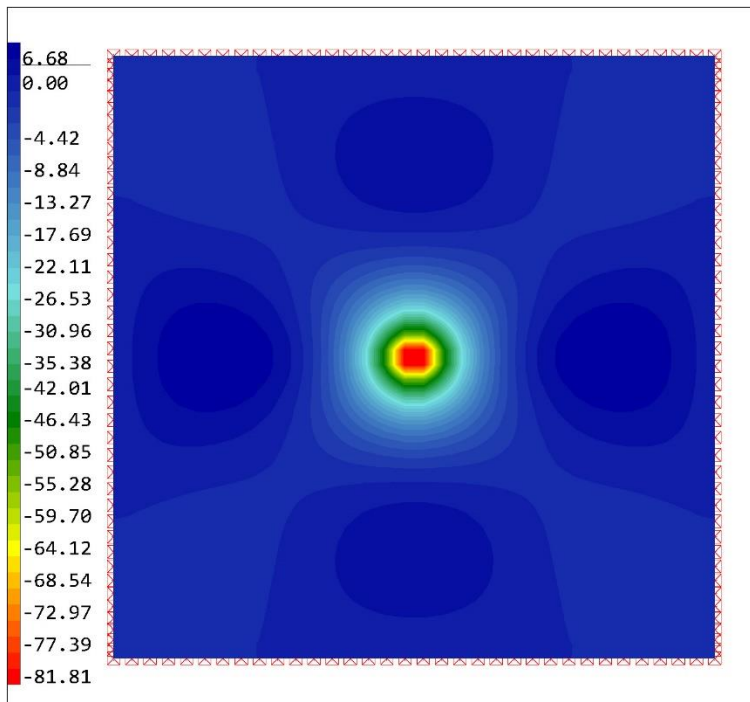


Figure 2. Deflections (mm) of the model with height of 3 m, prestress of 3 kN/m, elastic modulus of 600 kN/m and shear modulus of 30 kN/m under the concentrated load

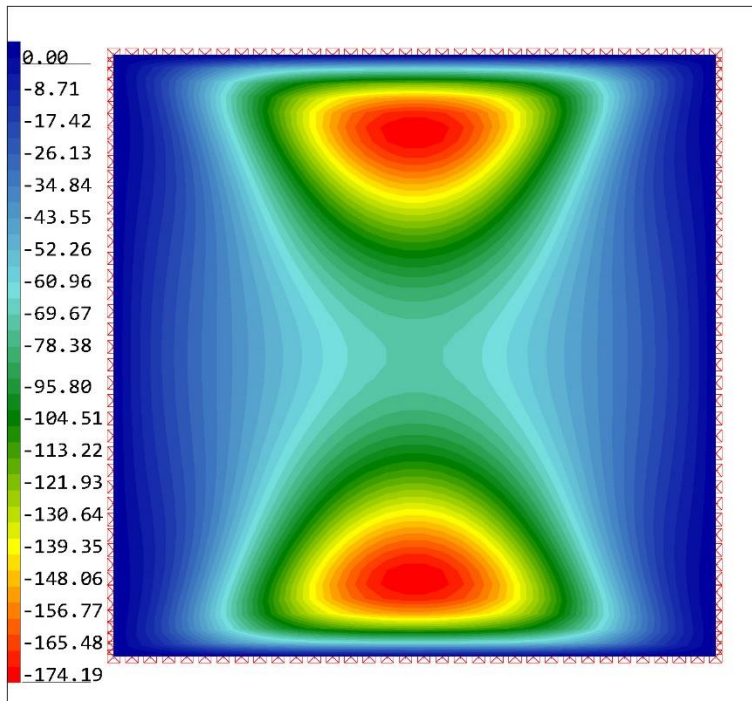


Figure 3. Deflections (mm) of the model with height of 3 m, prestress of 3 kN/m, elastic modulus of 600 kN/m and shear modulus of 30 kN/m under the snow load

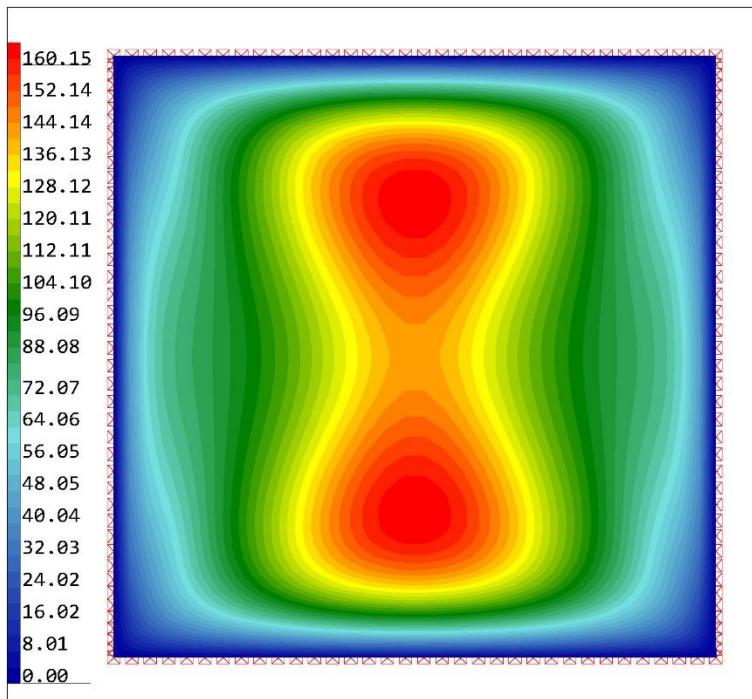


Figure 4. Deflections (mm) of the model with height of 3 m, prestress of 3 kN/m, elastic modulus of 600 kN/m and shear modulus of 30 kN/m under the wind load

Due to space limitations, it was not possible to show the arrangement of deflection values for all analyzed models. Therefore, in the next part the results for the maximal

deflections of models are given. The results are related to the varied parameters. The chart shown in Figure 5 shows the relation of membrane properties and the maximal deflections under all analyzed loads. Figure 6 provides the results for the maximal deflections under different model heights. The values for maximal deflections under varying prestress intensities are given in Figure 7.

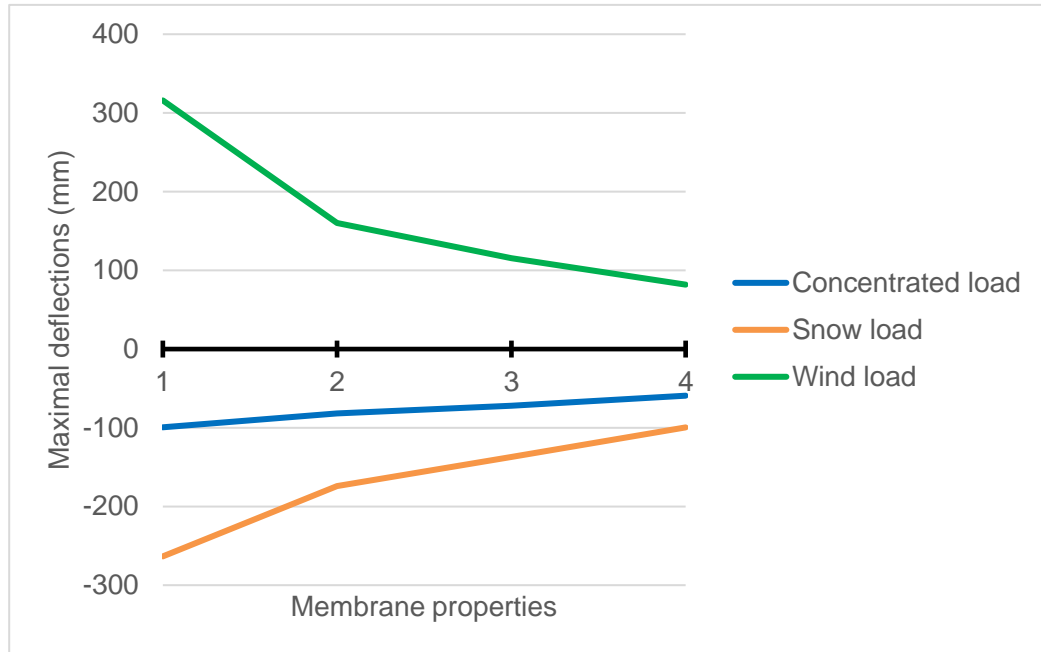


Figure 5. Maximal deflections in vertical axis under different loads and membrane material properties

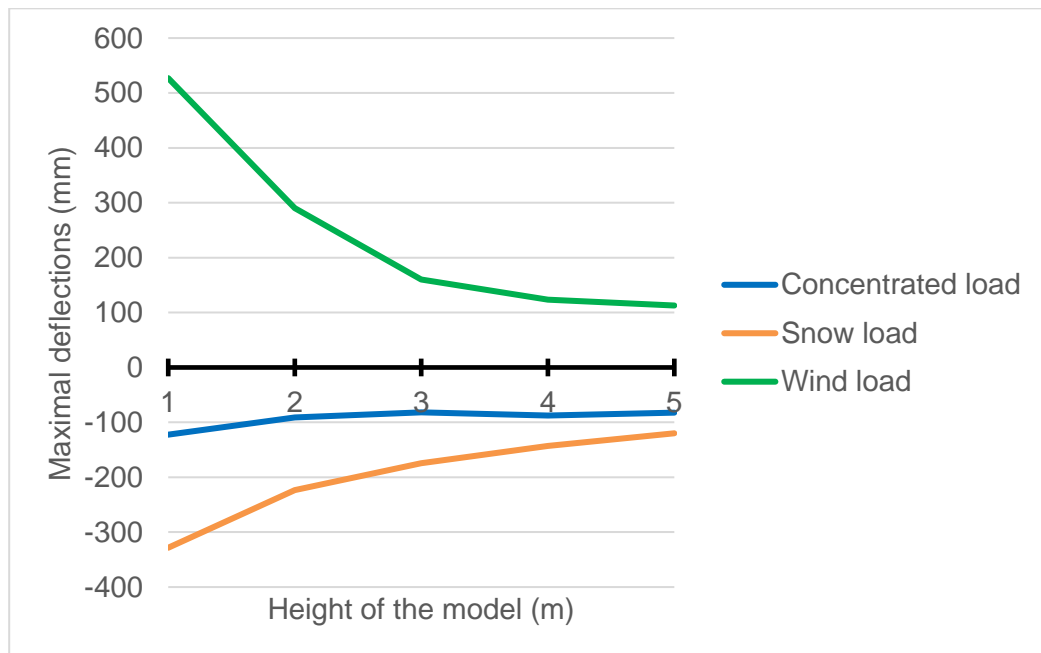


Figure 6. Maximal deflections in vertical axis under different loads and membrane height

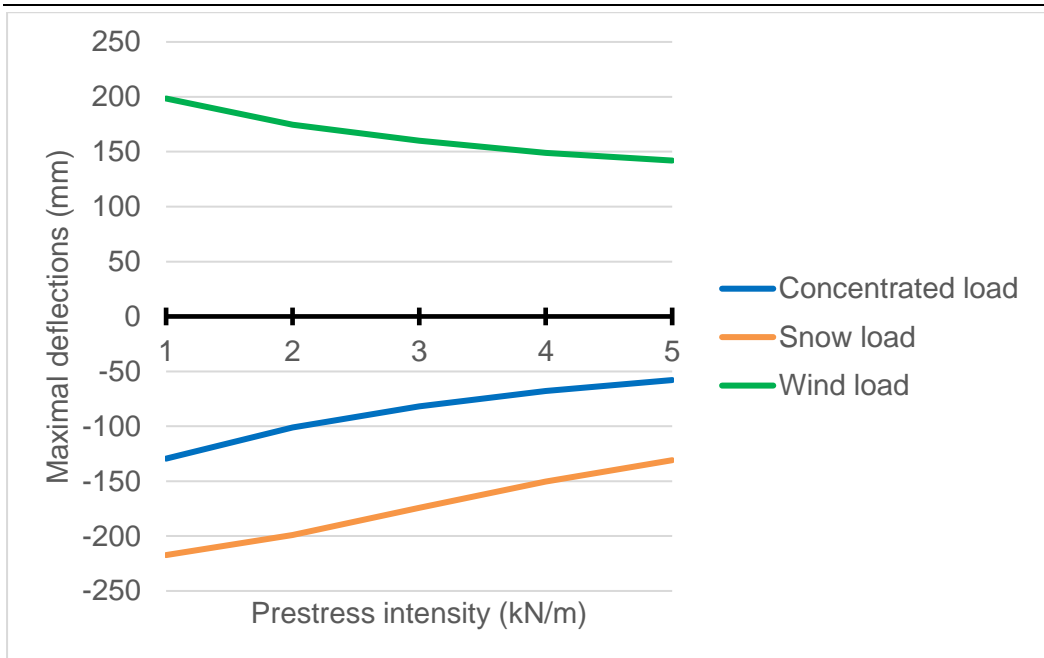


Figure 7. Maximal deflections in vertical axis under different loads and membrane prestress values

It should be noted that all deflections are given for the vertical axis with the positive direction upwards. Therefore, the wind that has an upward direction produces positive deflections. Contrary to this, the concentrated load and wind load produce negative maximal deflections.

#### 4. DISCUSSION

The results of the model with the height of 3 m, membrane properties 2 and the prestress of 3 kN/m are discussed first. As Figure 2 shows, the concentrated load has a very local effect on the membrane, when deflections are considered. The central part of the membrane, where the load is applied, deflects down and the maximal deflection is 81.81 mm. Most of the membrane deflects very little and, in some parts, even upward deflections are noted. Under snow load, the membrane of the same model deflects down to 174.19 mm. The results are provided in Figure 3. However, in this case the whole membrane deflects significantly. The membrane edges are fixed, but the deflections gradually increase from the edges to the areas of maximal deflections. It is interesting to notice that the maximal deflection does not occur at the center of the membrane, as it might be expected. At the first glance, the center of the membrane seems like a place where the maximal snow load deflections will happen, due to its farthest position from the fixed edges. However, since the membrane strongly relies on its curvature to resist external loads, another area shows the most sensitivity to snow load. This is the part of the membrane close to the straight edges. The maximal deflections occur at the position between the middle of the straight edge and the center of the membrane, symmetrically, on both sides of the membrane. This is where the two important factors, membrane curvature and distance from the support, provide the largest effect, deflection-wise.

Deflection results from the applied wind load are given in Figure 4. Here there are no parts of the membrane that deflect in the direction opposite to the load action, and all points deflect upward. The same was the case with snow load. The arrangement of displacements is similar to those under snow load. Deflection values gradually increase from the edges inwards. The position of the maximal deflections is close to the maximal deflection under snow load, between the middle of the straight edge and the center of the membrane. Maximal deflection in this case is 160.15 mm. When compared to the other loads, this deflection is significantly higher than the one produced by the concentrated load and somewhat lower than the snow load deflection. The fact that the wind load has higher intensity than the snow load leads to the expectation that wind load will produce larger deflections, which is here not the case. Therefore, it will be further analyzed on other models.

The influence of analyzed membrane material properties on the value of maximal deflections is given in Figure 5. The data shows that the increase of elastic and shear modulus of the membrane material results in lowering the maximal deflections under all three loads. In all models the concentrated load produces the lowest deflections. In addition, the value of maximal deflection under concentrated load is the least affected by the change of membrane material. Figure 6 shows the dependence of maximal deflections on the height of the model, under all loads. The graph is very similar to the previous one. The important difference is that the maximal deflections under concentrated load exhibit even less dependence than with the material properties, and even show slight increase in one instance. Deflections under other two loads show even more visible dependence on the value of the varied parameter. The influence of prestress intensity is depicted in Figure 7. This chart shows that the influence of the prestress intensity on the concentrated load deflections is larger than that of the other two variables, and, at the same time, lower when considering wind and snow load. Therefore, all three loads have similar sensitivity to prestress change. When compared to other loads, the deflections under concentrated load are still the smallest in all cases, but the difference is not so large. This is not in line with some other researches [5,6] where the concentrated load showed much more significant deflections.

Finally, the relation between the value of snow and wind load maximal deflections is analyzed. The maximal deflection under wind load is larger only when the elastic and shear modulus have the lowest analyzed values. With the increase of these values, the snow load deflections get larger than the wind load deflections. For lower models, the wind load deflections are larger, while for the higher the contrary is true. Under the highest analyzed prestress intensity, wind load has a larger maximal deflection, while for all other cases deflections from snow are larger.

## 5. CONCLUSION

This paper presents the results of the research on the deflections of the barrel vault shaped membranes. It is a part of broader research dealing with the effects of external loads on membrane structures. Generally, the focus is on obtaining, presenting and discussing data that can be of assistance to engineers designing tensile membranes. In the part of the research elaborated in this paper, numerical models of membranes were created and analyzed. The applied methodology strongly relies on the previous researches, but introduces some new elements. In



such way, new results are obtained, thus allowing for some new conclusions that can consequently be applied in practice.

The results show that the concentrated load produces significantly different effects compared to the other loads, which was expected. This is especially visible with the arrangement of displacements, that are very concentrated in the area of load application. At the same time, maximal displacements are in most cases much lower under concentrated loads. The wind load and the snow load produce a similar arrangement of deflections. In both cases, maximal deflections are not at the center of the membrane of the analyzed model. The part of the membrane most sensitive to deflections is the one between the middle of the straight membrane edge and the center of the membrane. This is where the membrane curvature and the distance from the supports have the least favorable combined effect. The intensity of maximal deflections is generally similar for these two loads, despite their different application direction and intensity. The relation of these two intensities is commented based on the value of the three analyzed parameters. The increase of membrane elastic and shear modulus, the height of the structure and the intensity of the membrane prestress, all result in lowering the maximal deflections under all loads. The only exception is the maximal deflection under concentrated load, that shows indifference, and in one case even increase, when the height of the model is increased.

The possible next steps for research are the analysis of other sizes of barrel vault membrane shape, different membrane material properties in main directions and other prestress ratios. Cone shaped membranes need to be analyzed as well. Experiments with dynamic loads or physical experiments would be a great next step on the path of this research. Finally, it can be concluded that the main goal of this research is fulfilled. New results are obtained, showed and explained, thus widening the existing body of knowledge. The conclusions from this part of the research on the deflections of barrel vault shaped membranes will be compared with those from other parts and published in the near future.

## ACKNOWLEDGMENTS

This collaborative research was supported by the COST Action CA20138 NEXUSNET.

## REFERENCES

- [1] Bridgens B, Birchall M: **Form and Function: The Significance of Material Properties in the Design of Tensile Fabric Structures.** *Engineering Structures*, 44, 1-12, 2012.
- [2] Uhlemann J: **Elastic Constants of Architectural Fabrics for Design Purposes.** *PhD Thesis, Universität Duisburg-Essen*, 2016.
- [3] Colman A, Bridgens B, Gosling P, Jou GT, Hsu XY: **Shear Behaviour of Architectural Fabrics Subjected to Biaxial Tensile Loads.** *Composites Part A: Applied Science and Manufacturing*, 66, 163-174, 2014.
- [4] Zhang Y, Zhang Q, Yang Z, Chen L, Cao Y: **Load-Dependent Mechanical Behavior of Membrane Materials and its Effect on the Static Behaviors of Membrane Structures.** *Journal of Materials in Civil Engineering*, 27, 1-11, 2015.

- 
- [5] Milošević V, Marković B: **Comparison of point and snow load deflections in design and analysis of tensile membrane structures**, *Advances in Civil Engineering*, 8810085, 2020.
- [6] Milošević V: **Aspekt promene geometrije pri dejstvu koncentrisane sile u projektovanju montažnih membranskih konstrukcija**. *Doktorska disertacija, Građevinsko-arhitektonski fakultet Univerziteta u Nišu*, 2018.
- [7] Milošević V: **Projektovanje membranskih konstrukcija - Analiza ugiba pod opterećenjima**, *Građevinsko-arhitektonski fakultet Univerziteta u Nišu*, 2022.
- [8] Xu J, Zhang Y, Wang Y, Song J, Zhao Y, Zhang L: **Quasi-static puncture resistance behaviors of architectural coated fabric**. *Composite Structures*, 273, 114307, 2021.
- [9] Gosling, P.D., Bridgens, B.N., Albrecht, A., Alpermann, H., Angeleri, A., Barnes, M., Bartle, N., Canobbio, R., Dieringer, F., Gellin, S., Lewis, W.J., Mageau, N., Mahadevan, R., Marion, J.-M., Marsden, P., Milligan, E., Phang, Y.P., Sahlin, K., Stimpfle, B., Suire, O., Uhlemann, J.: **Analysis and Design of Membrane Structures: Results of a Round Robin Exercise**. *Engineering Structures*, 48, 313-328, 2013.
- [10] Liu C, Dend X, Zheng Z: **Nonlinear wind-induced aerodynamic stability of orthotropic saddle membrane structures**. *Journal of Wind Engineering and Industrial Aerodynamics*, 164, 119-127, 2017.
- [11] Forster B., Mollaert M.: **European Design Guide for Tensile Surface Structures**. *TensiNet*, Brussels, 2004.
- [12] Stranghoner N, Uhlemann J, Bilginoglu F, Bletzinger KU, Bogner-Balz H, Corne E, Gibson N, Gosling P, Houtman R, Llorens J, Malinowsky M, Marion JM, Mollaert M, Nieger M, Novati G, Sahnoune F, Siemens P, Stimpfle B, Tanev V, Thomas JC: **Prospect for European Guidance for the Structural Design of Tensile Membrane Structures**. *European Commission, Joint Research Centre, Luxembourg*, 2016.
- [13] **Tensile Membrane Structures**. *ASCE Standard, ASCE/SEI 55-10, ASCE, SEI, Reston*, 2010.
- [14] Milošević V, Kostić D, Vasov M, Randelović D, Marchwiński J: **Fabric stresses of numerical models of barrel-shaped tensile membrane structures under different loads**. *X Konferencja Naukowo-Techniczna ARCHBUD 2023*, accepted for publication, Zakopane, 2023.

## BIOPHILIC DESIGN PRINCIPLES IN WORKPLACE

Stela Skrizhovska-Koleva<sup>1</sup>

### Abstract

*The effects of climate change and the covid pandemic in recent years have made biophilic design more attractive than ever. Architects and designers have the responsible task of introducing innovations and promoting the use of materials that bring the artificially built environment closer to the natural one.*

*The report presents the practical challenge of applying biophilic design in the solution of the architecture of workspaces. Examples of workplaces have been analyzed, and the main principles of applying biophilia in their interiors have been touched upon. Biophilic design is outlined as a set of attributes, principles and practices for workplaces to bring nature into urbanites' daily life. It allows for improved comfort and performance of the people occupying built spaces through the inclusion of natural elements in the buildings, such as water, non-artificial light or plants. „Biophilic design seeks to link our intrinsic need for affiliation with nature to the modern built environment [1]“.*

**Key words:** *Architecture, Biophilic Design, Workplace*

---

<sup>1</sup> Dr. Arch., Chief Assist. Prof., University of Architecture, Civil Engineering and Geodesy, skrizhovska\_far@uacg.bg

## **1. INTRODUCTION**

Over the past decades, the work environment has changed rapidly, the dynamics being related to the updating of technologies, modern types of production, the pandemic situation and remote communications. Man is faced with new challenges related to working spaces – the professional environment is mixed with that of living and leisure, and the boundaries are blurring more and more.

The concept that is used in architecture to increase the users' connectedness with the natural environment through the use of nature and site and space conditions is the biophilic design. It has a wealth of benefits for urban environment and building occupants through improving connections to nature. The idea of making the city more resilient to any environmental stressor it may face is the biggest proponent of the biophilic design.

“Biophilia emerges in the 1970s from the understanding that humans evolved with a deep connection to nature and was described by psychoanalyst Erich Fromm as “The passionate love of life and all that is alive”. The innate human sense of wellbeing from nature is profound [2].”

One of the solutions contributing to a better and more efficient work environment is the use of biophilic design in the interior of the workplace. Thus, the everyday life of the workers becomes more pleasant and relaxing, and their work more efficient. “The biophilic design framework encompasses distinct but interrelated elements [3].”

## **2. DEFINITION**

The term biophilia was first used by psychologist Erich Fromm in 1964, then popularized by biologist Edward O Wilson in the 1980s when he argued how urbanization leads to a disconnection with nature.

“Biophilic design is the deliberate attempt to translate an understanding of the inherent human affinity to affiliate with natural systems and processes – known as biophilia – into the design of the built environment” [4].

## **3. RELEVANCE OF THE TOPIC**

The topicality of the topic is related to the need for a more efficient working environment for the dynamic everyday life in the modern world, in which people can relax and feel closer to nature.

## **4. BIOPHILIC DESIGN PRINCIPLES AND ELEMENTS**

Biophilic design includes a set of concepts that an architect can use. Some of the most common ideas include: landscaping on exterior walls, interiors, roofs, using natural light, trying to break the barrier between inside and outside by using all kinds of openings, introducing water features, if it is possible - encouraging and attracting wildlife, especially insects and small birds, using images and colors associated with the natural world, borrowing natural forms found in nature and using them on facades, plans and walls, using natural materials, especially timber, clay or stone in construction, interior spaces and furniture.

Elements of biophilic design are: color, air, water, sunlight, plants, animals, natural materials, views, facade and interior landscaping, even fire.

## 5. ANALYSIS OF EXAMPLES

Factory in the Forest/Design Unit Architects Snd Bhd is located in Penang, Malaysia and was built in 2017. The building is realized as a volume surrounded by greenery that also penetrates inside it, creating maximum contact with nature. A large pergola covering the entire site provides sun protection and creates a visual internal volume and courtyard to the workspaces – Figure 1.



Figure 1. Factory in the Forest, [https://www.archdaily.com/947771/factory-in-the-forest-design-unit?ad\\_medium=gallery](https://www.archdaily.com/947771/factory-in-the-forest-design-unit?ad_medium=gallery)

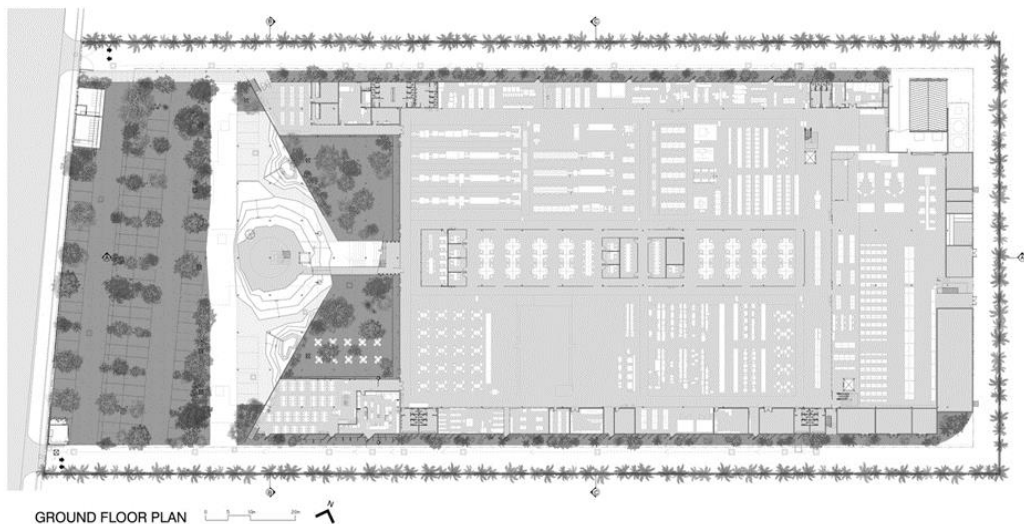


Figure 2. Factory in the Forest – grand floor, [https://www.archdaily.com/947771/factory-in-the-forest-design-unit?ad\\_medium=gallery](https://www.archdaily.com/947771/factory-in-the-forest-design-unit?ad_medium=gallery)

The main principles of sustainable design are embedded in the project - energy efficiency, water efficiency, daylight and biophilia - the human need for connection with nature, and the western facade of the building is shaped like an open courtyard - Figure 2.

Biophilia in Factory in the Forest is realized through the smooth entry of plants into the building, providing not only a pleasant working environment, but also a suitable microclimate, which reduces the use of electricity.

Pasona Urban Farm represents a modern reading of an agricultural building in urban conditions – Figure 3. Kono Architects revitalized the existing office building using biophilic design, improving the work environment by having people in the building have direct contact with fertile plants and flowers grown on all floors of the building inside – Figure 4 a), b), as well as on the two-layer facades from the outside.

Using both soil-based and hydroponic farming, the design puts crops and office workers in a common space. An intelligent climate control system monitors the temperature, humidity and airflow in the building to balance human comfort during working hours and optimize crop growth during non-working hours. This maximizes annual harvests and yield. Air sampling at Pasona's headquarters showed a reduction in carbon dioxide where plants are abundant, reducing the need for ventilation and therefore costs. But at the same time as the benefits for workers, living vegetation significantly reduces the cost-effective area for offices.

Through biophilic design, workers are provided with improved mental health, increased productivity and relaxation in the workplace [5].



Figure 3. Pasona Urban Farm, <https://www.dezeen.com/2013/09/12/pasona-urban-farm-by-kono-designs/>



Figure 4. Pasona Urban Farm: a) basic floor plan, b) meeting room,  
<https://www.dezeen.com/2013/09/12/pasona-urban-farm-by-kono-designs/>

The SelgasCano studio's renovation project for Lisbon's oldest food market, the Mercado da Ribeira, built in 1892, transforms its ground floor into a shared workspace, with the architects creating the space through new top and side glazing to let in natural light, inserting over a thousand potted plants to divide the spaces (while silencing noise and purifying the air) according to the principle of biophilic design, and coloring the floors, some of the furnishings and the visible structure with bright warm colors in contrast to the white ceiling, so to create an aesthetically appropriate working environment – Figure 5. The design of the shared workspace creates a feeling of workplaces outside the office, in an environment close to nature, with biophilia improving the aesthetics and psychological state of the workers – Figure 6a)b). Of course, its maintenance requires additional costs and maintenance.

The design of Second Home Lisbon is a logical response to the changing patterns of work and the increasingly blurred separation between personal life and work, which after the covid crisis is becoming more common.

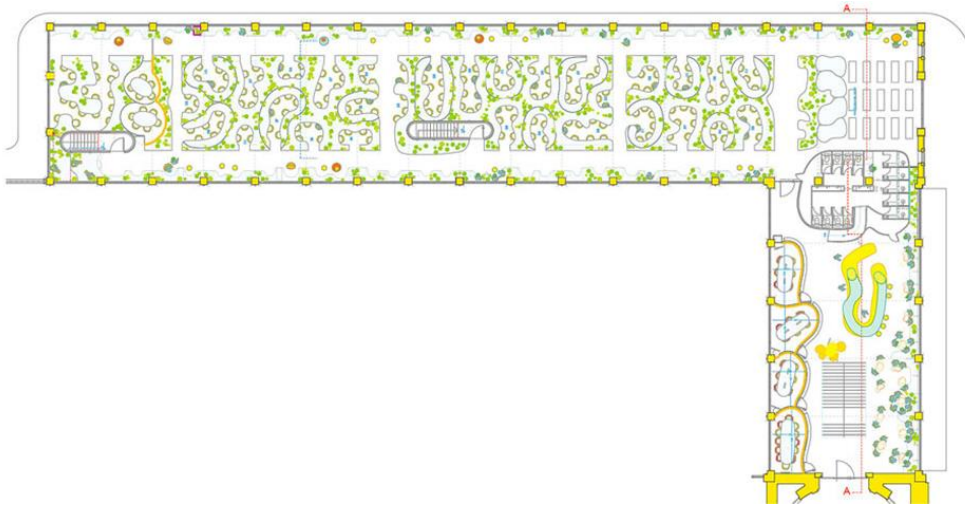


Figure 5. Second Home Lisbon - distribution - the workplaces look like corners in a garden, <https://www.abitare.it/en/architecture/projects/2017/07/13/selgascano-co-working-lisbon/>



Figure 6. Second Home Lisbon: a) shared working space, b) route along the periphery, <https://www.abitare.it/en/architecture/projects/2017/07/13/selgascano-co-working-lisbon/>

The most iconic part of the Amazon headquarters in Seattle are the three glass spheres that house a multi-story botanical garden, realized according to the principles of biophilic design for the workplace. Waterfalls and dense living walls create a jungle feel. The microclimate in the spheres is set with different indicators depending on the part of the day to be suitable for the plants, which increases the maintenance costs.

Spheres represent only two percent of Amazon's complex, but they are a magnet for social contacts and, accordingly, for bringing people together. They contrast against the background of the surrounding buildings – Figure 7, Figure 8a). Open to Amazon employees, they offer places to meet, work and dine, from a “bird's nest” with wooden bars to terraces with benches and chairs - Figure 8b).



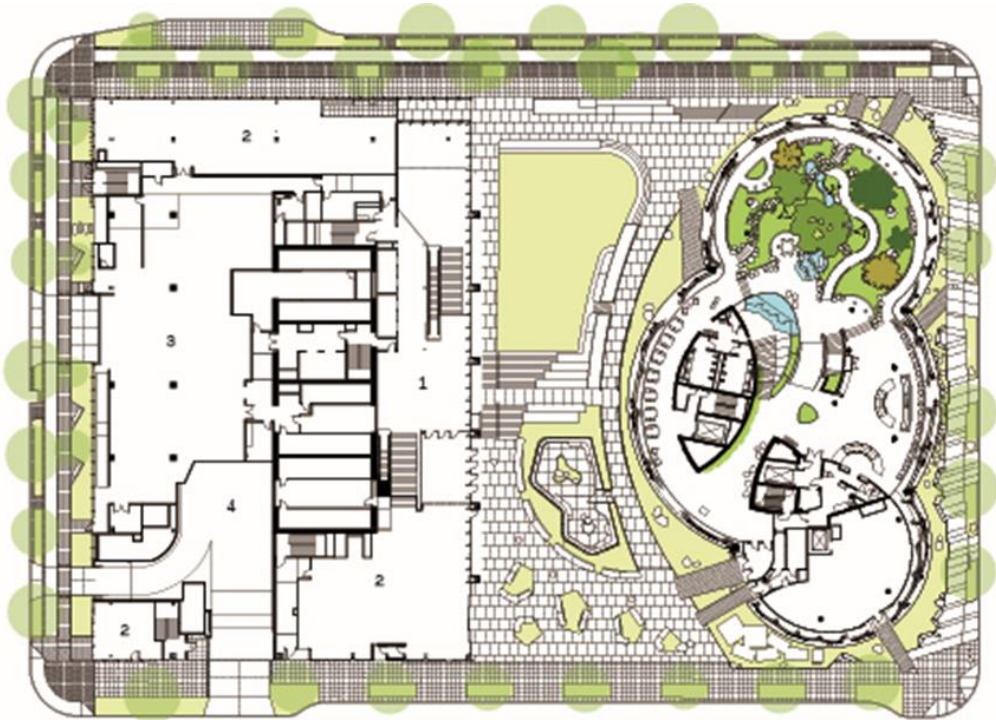


Figure 7. Amazon - on the left distribution of the first floor of the office building: 1. lobby, 2. sales, 3. charging, 4. entrance to the garage, on the right - distribution of the three areas: the contrast in the planning solution is great,  
[https://www.archdaily.com/920029/amazon-spheres-nbbj?ad\\_medium=gallery](https://www.archdaily.com/920029/amazon-spheres-nbbj?ad_medium=gallery)



Figure 8. Amazon - the three glass spheres: a) view from outside, b) view from inside with seating areas, [https://www.archdaily.com/920029/amazon-spheres-nbbj?ad\\_medium=gallery](https://www.archdaily.com/920029/amazon-spheres-nbbj?ad_medium=gallery)

The Bank of America Tower at One Bryant Park in downtown New York, designed by Cook + Fox Architects, is the first commercial skyscraper to receive LEED Platinum certification [6].

The green roofs and urban garden room bring the nearby park into the architecture and, combined with the lobby's natural materials - highest-fossil limestone on the walls and Israeli Kashmiri white granite on the floor - emphasize the natural elements that can be found in urban life – Figure 9a). Thus, natural

materials improve the psychological state of workers by creating a space with a connection to nature and at the same time improve the aesthetic qualities of the environment – Figure 9b).

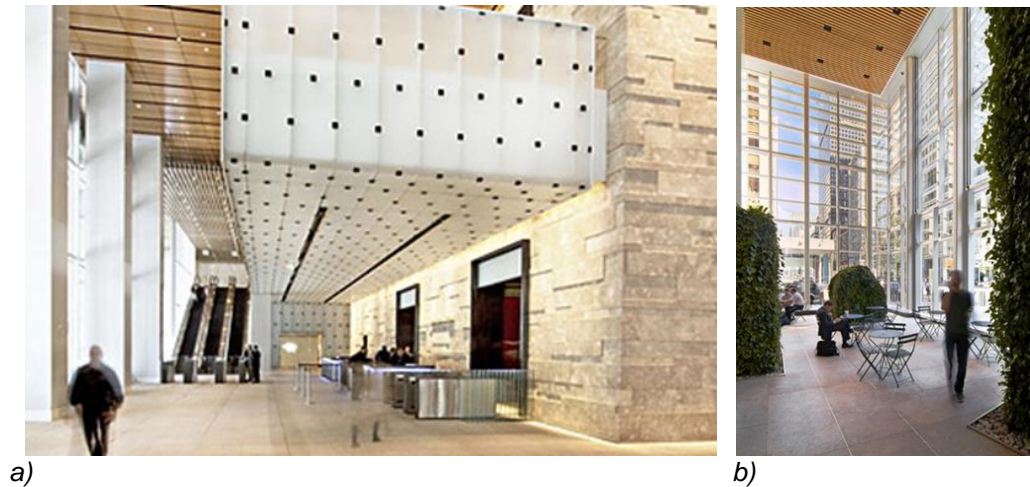


Figure 9. The Bank of America Tower: a) lobby, <https://content.time.com/time/health/article/0,8599,1994554,00.html>, b) public space, [https://www.archdaily.com/247880/bank-of-america-tower-at-one-bryant-park-cook-fox-architects?ad\\_medium=gallery](https://www.archdaily.com/247880/bank-of-america-tower-at-one-bryant-park-cook-fox-architects?ad_medium=gallery)

## 6. ADVANTAGES AND DISADVANTAGES

Biophilic design offers many benefits, both for people in their workplace and for the environment, such as:

- Improved health and psyche: studies prove that the presence of natural elements in interior spaces can improve concentration and reduce stress [7]
- Energy savings: By taking advantage of natural light and promoting natural ventilation, biophilic design can help reduce energy consumption and therefore reduce greenhouse gas emissions

- Aesthetics: Natural elements bring a sense of calm and beauty to spaces, which can make the work environment more pleasant and inviting

Despite its many advantages, biophilic design also has some disadvantages:

- Costs: Incorporating natural elements and environmental management systems into a building often increases construction and maintenance costs

- Maintenance: Plants and other natural elements require regular maintenance, which comes with additional labor and expense.

- Space: In some cases, incorporating natural elements into a building design and especially in workplace can reduce the available usable space.

Biophilic design is not a single element, but a different way of approaching design and a variety of concepts, building an artificial environment and putting the person at the center.

## 7. CONCLUSIONS

In today's dynamic everyday life, more than anyone needs a relaxing work environment, and although biophilic design has its disadvantages, its advantages are more and significant.

For the architects and designers it is good to know its principles in order to use it appropriately in your projects, so as to derive the maximum benefits both for the users of the urban environment and for nature.

The results of using biophilic design depend much more on related and complementary interventions in the overall environment than on single or isolated natural elements. The main impact of biophilic design is achieved through repeated contact with an environment organized according to its principles.

„The successful application of biophilic design fundamentally depends on adopting a new consciousness toward nature, recognizing how much our physical and mental wellbeing continues to rely on the quality of our connections to the world beyond ourselves of which we still remain a part [8].“

Biophilic design creates a unique work environment that encourages work activity, creates an opportunity for future sustainability and enables the development of social contacts. It is the future of the modern workplace.

## REFERENCES

- [1] <https://www.dezeen.com/2022/09/16/architectural-ceramic-assemblies-workshop-buro-happold-cookfox-architects-facade-design/> (09.4.2023.)
- [2] Paul Watts, Rebecca Rawson, Uchechukwu Okere: **The importance of biophilic design: a person-centred approach.** *Journal of ecopsychology Vol 3, Article 4, ISSN 2752-5260, 2023*
- [3] Weijie Zhong, Torsten Schröder, Juliette Bekkering: **Biophilic design in architecture and its contributions to health, well-being, and sustainability: A critical review.** *Elsevier, Frontiers of Architectural Research 11(1):114-141, DOI: 10.1016/j.foar.2021.07.006, 2022.*
- [4] Stephen R. Kellert, Judith Heerwagen, Martin Mador: **Biophilic Design: The Theory, Science and Practice of Bringing Buildings to Life.** *Wiley, ISBN 978-0-470-16334-4, 2008.*
- [5] <https://www.designcurial.com/news/biophilic-design-and-architecture---10-of-the-best-biophilic-buildings-4527750/4> (14.04.2023.)
- [6] [https://www.archdaily.com/247880/bank-of-america-tower-at-one-bryant-park-cook-fox-architects?ad\\_medium=gallery](https://www.archdaily.com/247880/bank-of-america-tower-at-one-bryant-park-cook-fox-architects?ad_medium=gallery) (10.04.2023.)
- [7] <https://en.fenarq.com/2023/05/biophilic-design.html> (10.04.2023.)
- [8] <https://metropolismag.com/viewpoints/what-is-and-is-not-biophilic-design/> (02.08.2023.)

# THE LARGE-SCALE COLLECTIVE HOUSING OF SOCIALIST YUGOSLAVIA – THE INTRODUCTION AND DEVELOPMENT OF A NEW WAY OF CITY LIFE

Violeta Stefanović<sup>1</sup>

## Abstract

*The formation of socialist Yugoslavia after the Second world war, along with rapid industrialization and mass migration, opened the way for the reimagining of residential architecture and, consequently, city life. This venture was guided by two ideologies – socialist and modernist. The socialist ideology created an environment in which housing became one of the focal points of the state's apparatus. On the other hand, the purely architectural modernist ideology extremely present in the architectural discourse of that time, represented the aspiration for opening a new chapter in the creation of cities. This gave architects the opportunity to envision, design and continuously develop housing concepts, which went hand in hand with technological and building innovations. Large-scale collective housing complexes represented a new way of co-habitation and a thorough change in living conditions, since traditionally built, single family houses were dominant beforehand. This architectural and civil engineering endeavor introduced the now dominant way of city living. The aim of this paper is to research the development of housing concepts realized during the socialist period, so as to better understand their advancement. By analyzing two examples of city blocks in the Liman area of Novi Sad, Serbia, one built in the beginning of this significant housing venture, and the other built near the end of this period, we are able to evaluate both in terms of their spatial concepts and resulting living conditions. This research will give us the opportunity to understand the development of the collective housing concepts which introduced the way of city living that is dominant today. At the same time, it will also highlight how important continuously striving for improvement is in the field of residential architecture and urbanism, since that can lead to great positive changes in the overall life quality and everyday lives of residents.*

**Key words:** *collective housing, socialist, Yugoslavia, city life, development, Novi Sad*

---

<sup>1</sup> M.Sc. Arch. and PhD candidate, Senior Scientific Researcher, University of Novi Sad, Faculty of Technical Sciences, Department of Architecture and Urbanism, Novi Sad, Serbia, violeta.stefanovic@live.com / violeta.stefanovic@uns.ac.rs

## 1. INTRODUCTION

The formation of socialist Yugoslavia after the Second World War, accompanied by rapid industrialization and mass migration created the preconditions for residential architecture and housing to become, perhaps, the most daring project of the newly created state, realized through the change of the concept of forming the housing fund. A mass migration of people from rural to urban environments arose as a consequence of the rapid progress, which created a great need for finding a new solution for the housing crisis. This necessity, as well as the conditions created in the newly formed socialist state, enabled and encouraged the architects active in that period to deliberate and envision residential space, which would result in various new spatial concepts. Guided by two ideologies – socialist and modernist, architects were given the opportunity to create new forms of housing. The socialist ideology, with its paradigms concerning social equality and its need to indicate the future prosperity of the state, as well as the importance of the unification of the republics, created an environment in which housing was not only an architectural, but an extremely important political question. On the other hand, the purely architectural modernist ideology, which was at that time extremely present in the architectural discourse, based on progress in all possible senses and which was assisted by the development of technology, represented the aspiration for opening a new chapter in the creation of cities, and consequently, city life. The correlation of these two distinctive guidelines created complex conditions for the deliberation and formation of new urban and housing concepts which would introduce a new way of city life. These large-scale collective housing complexes were a reasonable answer to the huge influx of citizens who were moving from rural to urban areas as a consequence of rapid industrialization, but they also provided the opportunity to realize a new architecture for a new state. As a result of these complex factors, the citizens of socialist Yugoslavia suddenly underwent a thorough change in their everyday lives, stemming from the extremely different living environment they were now inhabiting. Until then, traditionally built one-family houses were predominant [1].

Through this thorough shift in living conditions, the citizens of socialist Yugoslavia were moving from privately-owned traditionally built single-family houses to state-owned (society-owned) large multi-family buildings and exchanging their private yards for common block areas. Thus, they were now in the position where they were rebuilding the picture of their everyday lives in all possible ways. One of the key changes this collective housing brought with it is that the residential density realized in these newly formed collective housing complexes, as well as communal spaces, were bound to alter the way the residents form social relations, communal values and communities as a whole. If communities are defined as aggregates of people who share common activities and/or beliefs and who are bound together principally by relations of affect, loyalty, common values, and/or personal concern (i.e., interest in the personalities and life events of one another) [2] and a city community rests and survives on territorialized social relations which are mediated by urban interventions in space [3], the link between the shared residential area and the resulting community is undeniable. Also, the physical characteristics of a neighborhood, including its housing design and density, street connectivity, land use mix, and the availability of public spaces, may lead to more or less opportunities for social engagement among neighbors [4]. Therefore, the spatial frames of the new large-scale collective housing complexes created preconditions which enabled new

possibilities for the creation of urban communities, as well as created new elements and factors which affect the overall quality of life in these residential areas.

Seeing as this architectural and civil engineering endeavor introduced the now dominant way of city living, the aim of this paper is to research the development of housing concepts realized during the socialist period, so as to better understand their advancement. These new housing concepts were continuously developed during the socialist period, going hand in hand with the technological, economic and cultural progress of the Federation. By analyzing two examples of city blocks in the Liman area of Novi Sad, Serbia, one built in the beginning of this significant housing venture, and the other built near the end of this period, we are able to evaluate both in terms of their spatial concepts and resulting living conditions. This research will give us the opportunity to understand the development of the collective housing concepts which introduced the way of city living that is dominant today.

## **2. THE LIMAN AREA IN NOVI SAD AND ITS RESIDENTIAL BLOCKS**

The city of Novi Sad went through numerous changes in the past, but its modernization is what characterizes it in a significant way even today. The biggest changes to the city's urban fabric were made after the Second World War, when the building activity was extremely high. The city went through several radical changes carried out by means of official urban planning documents. These changes shaped and defined the city, creating the urban morphology and identity it has today. When it comes to large-scale collective housing complexes realized during the socialist period, a great example in the city can be found in the Liman area. The area consists of four segments, Liman I, II, III and IV, whereas the numbering corresponds to the sequence of their realization – ranging from the beginning until near the end of the development of the collective housing of socialist Yugoslavia (Figure 1). The Liman area has been chosen as the focal point of this analysis seeing as it is a specific, significantly large spatial development that was both planned and realized during the socialist period, which, on one hand, makes it a fairly homogenous urban development, and on the other, represents a showcase of the evolution of the urban and architectural concepts and principles developed during the socialist period.

Therefore, in order to understand the extent of the development of collective housing concepts, this paper will analyze one block from the Liman I area and one block from the Liman IV area - seeing as they were, respectively, the first and last installments of this large spatial development, corresponding to the first and final decades of the socialist period. This will enable us to gain insight into the advancement of the conceptualization of the housing complexes, which went hand in hand with the progress of the Federation as a whole.



Figure 1. The Liman area and its segments, source of the original orthophoto image: GeoSrbija <https://a3.geosrbija.rs/>

### 2.1. A block in the Liman I area – built before 1960

Examples of the first collective housing residential blocks built during the socialist period in Novi Sad can be found in the Liman I area, the first installment of the entire Liman neighborhood. The blocks that can be found here are characterized by significant open space between buildings which is filled with green areas and vegetation, as well as necessary parking spaces. The block that will be analyzed in this paper represents a great example of this type of residential block. It was built before 1960, during the early stages of the conceptualization of collective housing complexes in socialist Yugoslavia.



Figure 2. A block in the Liman I neighborhood – morphology (left), source: Violeta Stefanović; orthographic photograph (right), source of the original orthophoto image: GeoSrbija <https://a3.geosrbija.rs/>

It should be noted that apart from buildings built when the block was realized, this residential block also features a few structures that were added at a later date: the longitudinal building alongside Dr Ilije Đuričića Street and small single-story structures (parking garages). Even though these additions are of a later date, the original spatial concept of the block has remained intact. That spatial concept can be described as an opened block, seeing as the inner open space can be reached from all of the surrounding streets (Figure 2). Apart from accessibility, this disposition creates significant space between the buildings, allowing for the formation of public green spaces in the collective courtyard of the block, as well as enabling sufficient ventilation. Due to this, a favorable microclimate is established.

The parking is situated inside of the block, alongside the buildings, which on one hand provides convenience due to the accessibility of the vehicles, but on the other hand, it makes the open space of the block less safe for residents and passers-by due to the traffic (Figure 3).

Also, seeing as communities are formed by social relations which are established through frequent contact, the lack of infrastructure in terms of designated spaces in which residents can spend time and interact, as well as the lack of urban furniture means that the residents are less likely to encounter and interact with one another.



*Figure 3. A block in the Liman I neighborhood – inner space, source: Violeta Stefanović, June 2019.*

From the analysis of the block's morphology, it is clear that the conception of this block was to enable good living conditions in terms of microclimate and the accessibility of public green spaces, as well as to envision a solution for the growing number of vehicles. However, even though the quality of life certainly benefits from these factors, there is a lack of planned public spaces, which limits the opportunities for residents to develop interpersonal relations, therefore limiting the possibilities for the creation of a strong urban community.



## 2.2. A block in the Liman IV area – built during the 1970s

As the Federation progressed over time, the living standard was being risen as well. The first two decades after the Second World War were marked by rapid construction on all fronts: infrastructural development, the massive construction of residential units, the realization of administrative and representative buildings and all other elements crucial for the state's primary existence. During the seventies, having realized the minimum standards for the state's functioning, socialist Yugoslavia reached a state of utter well-being. This period was characterized by strong enthusiasm and zest, which made way for more innovation regarding architecture and its programs. In terms of residential architecture, the impact this development had on housing can be seen through the further development of housing concepts and the wider programming of the blocks. Numerous realizations and the forming of entirely new city areas were also accompanied by theoretical and other research in the fields of habitology [5]. This wider programming of the blocks in terms of creating planned public spaces expanded the possibilities for socialization and the number of the residents' personal needs that could be met in their primary spatial frame.

Housing blocks located in the Liman IV area, which was the last of the four segments of the Liman area to be built are characterized by this wider programming that emerged in the seventies. Therefore, these blocks not only contain green areas and vegetation in their open spaces, as well as parking, but they are structured in a way that enables the creation of planned public spaces intended for numerous activities.

The block in the Liman IV area that will be analyzed in this paper was built in the 1970s and represents a great example of the later stages of the development of housing concepts in socialist Yugoslavia.

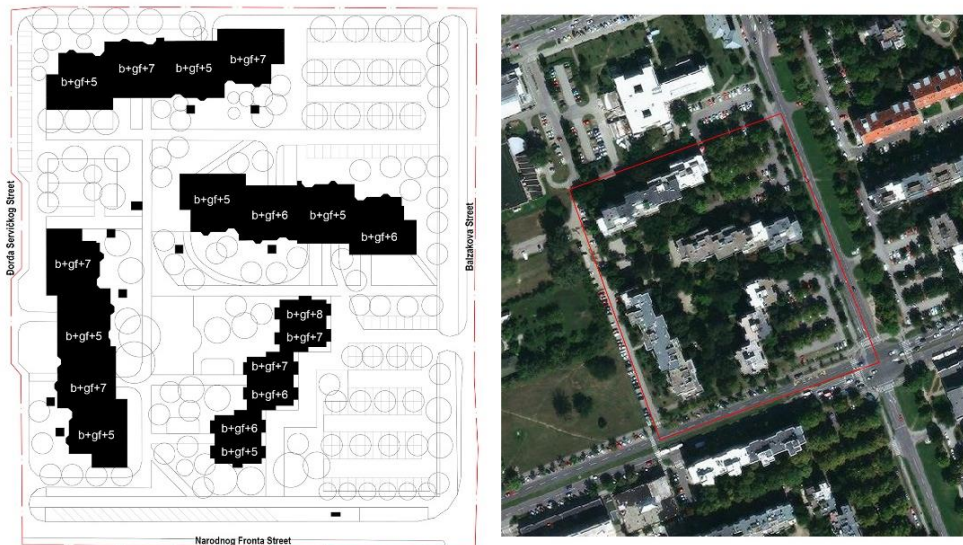


Figure 4. A block in the Liman IV neighborhood – morphology (left), source: Violeta Stefanović; orthographic photograph (right), source of the original orthophoto image: GeoSrbija <https://a3.geosrbija.rs/>

The morphology of the block indicates that the block can be characterized as an open one, with space between the buildings allowing access and the possibility of passing through the entire complex. The parking solution places the vehicles outside of the block area and places them in its outer corners, freeing up the inner courtyard and allowing the creation of public spaces. The juxtaposition of the buildings was planned so as to allow the formation of pathways, plateaus and a sports field, along with plenty of green space and vegetation (Figure 5).



*Figure 5. A block in the Liman IV neighborhood – inner space, source: Violeta Stefanović, June 2019.*

The amount of vegetation and space between buildings indicate a favorable microclimate, whilst the planned public spaces and numerous urban furniture create a spatial infrastructure which can allow the residents of the residential complex to frequently interact and take part in numerous activities. This enables the creation of interpersonal relations, which can lead to the formation and strengthening of communities.

### **3. DISCUSSION**

Through the analysis and figures presented in this paper, it is possible to overview the differences and similarities between spatial, urban concepts of collective housing complexes built in the socialist period in Novi Sad. Since forms of collective housing represent a space in which social aspects such as social relations of communities and spatial frames formed by architecture and urbanism intertwine, the examples analyzed in this paper need to be overviewed with both in mind.

As we have seen, the general conception visible in the block located in the Liman I area, built before 1960, was to create such a juxtaposition of buildings to allow for the creation of an open block, whilst the inner area is filled with green spaces and

vegetation. This ensures a favorable microclimate and sufficient privacy for the residents. The block built during the 1970s in the Liman IV area still shows that same principle. However, due the Federation's progress, the inner space of the block was highly developed when compared to the earlier example. The wider programming of the block, as well as the positioning of parking spaces on its outer corners enabled the creation of planned public spaces, some more or less strictly defined, allowing for the space to be used freely and frequently by residents. The diversity of urban furniture and the function of spaces (plateaus for gathering, a sports field for basketball and futsal), as well as pathways intersecting amongst the vegetation offer a multitude of possibilities for encounters, taking part in collective activities and spending free time, all in the close proximity to the residential buildings. These aspects create opportunities for the development of social relations between members of the urban community residing in this urban housing complex.

#### **4. CONCLUSION**

The endeavor of creating new forms of residential architecture in socialist Yugoslavia was influenced by complex factors and characterized by constant development. As shown in this paper, this development went hand in hand with the changing of the cultural, social, political, economic circumstances in the Federation. At the beginning of this important project, with the correlation of the socialist and the modernist ideologies, the aim was to answer the need for housing due to the mass migration in a way that will also mark the beginning of a newly formed state and announce its future prosperity. This was achieved by the creation of collective large-scale housing complexes which introduced a new way of co-habitation and city life. The first examples, represented here by the block in the Liman I area, with vast open and green space, along with provided parking enabled very good life quality, due to the favorable microclimate and the number of needs that were met through this spatial frame. However, due to the state's progression, architects were able to continue their work and to further adapt and develop their concepts and ideas. The resulting spatial solutions offered more than the earlier examples, building on the good basic concepts already set up. The complexes created towards the end of the socialist period, like the one in the Liman IV area, also offer their residents communal spaces with multiple functions. This addition brings with it more chances for encounters and the establishing of social bonds, which can result in the creation of strong communities. Through the improvement of the original concepts, a new dimension was added to the everyday lives of residents – the possibility to not only meet their primary needs for shelter and safety with access to green areas and sunlight, but to meet their social needs as well. It gave them the opportunity to, through socializing with their neighbors, become a part of something greater than themselves, a community. Being able to connect with people in a communal environment on a daily basis, in our most narrow spatial frame – our place of residence, enriches life quality in a specific manner. The examples analyzed and presented in this paper showcase how important continuously striving for improvement is in the field of residential architecture and urbanism, since that can lead to great positive changes in the overall life quality and everyday lives of residents.

## ACKNOWLEDGMENTS

This research (paper) has been supported by the Ministry of Science, Technological Development and Innovation through project no. 451-03-47/2023-01/200156 “Innovative scientific and artistic research from the FTS (activity) domain”.

## REFERENCES

- [1] Stefanović, Violeta: **From socialist to post-socialist housing in novi sad, serbia: a shift in shaping communities.** *International conference INDIS 2021, Novi Sad*, 797-804, 2021.
- [2] Brint, Steven: **Gemeinschaft Revisited: A Critique and Reconstruction of the Community Concept.** *Sociological Theory* Vol. 19 No.1, 1–23, 2001.
- [3] Pajvančić-Cizelj, Ana, Knežević, Jelena: **Socio-prostorna transformacija i susedski odnosi u Novom Sadu (Socio-spatial transformation and neighborhood relations in Novi Sad).** *Annual Review of the Faculty of Philosophy, Novi Sad* Vol. XLII, No. 2, 441–455, 2017.
- [4] Pfeiffer, Deidre, Cloutier, Scott: **Planning for Happy Neighborhoods.** *Journal of the American Planning Association*, Vol. 82, No. 3, 1-13, 2016.
- [5] Alfirević, Đorđe, Simonović Alfirević, Sanja: **“Socijalistički stan” u Jugoslavii: obrazac ili tendencija? (“Socialist apartment” in Yugoslavia: paradigm or tendency?).** *Spatium* Vol. 40, 8–17, 2018.

# INVESTIGATION OF THE POSSIBILITIES OF USING “BUZZI-SPACE” APPLICATION IN ORDER TO PREDICT REVERBERATION TIME

Predrag Radomirović<sup>1</sup>

## Abstract

*The advancement of software tools has enabled a more precise and simple analysis of the acoustic performance of space. In order to get better acquainted with the tools available, it is necessary to conduct an analysis of their capabilities and shortcomings. For this reason, an experimental measurement of the reverberation time and software modeling of the acoustics was carried out within this study. Then, based on the results of the reverberation time, a proposal was given for interventions that would lead to the improvement of room acoustics. The aim of this study is to determine the existing acoustic characteristics and to improve them through the room acoustic treatment.*

*The research was conducted in two phases. Within the first phase, an experimental measurement of the reverberation time was carried out using the application "Buzzi-Space". And then, within the second phase, the reverberation time was examined by the Odeon tool, using a method of software modeling. After experimental measurement and software modeling, a comparative analysis of the obtained results was performed. The comparative analysis aims to check the coefficients of absorption of materials within the software model, as well as to check the measurement results with the application "Buzzi-Space". After that, the possibilities of improving the acoustics of the performing hall by interventions in the space were examined. The impact of interventions in space was examined by the method of software modeling. The results of the research provide an insight into the advantages and disadvantages of new tools for experimental measurement of reverberation time in the space, as well as the possibility of improving the room acoustics by treating the surface in the interior.*

**Key words:** Room acoustics; reverberation time; Odeon; Buzzi-Space; performance halls

---

<sup>1</sup> student, ped\_ja94@hotmail.com

## 1. INTRODUCTION

The development of software tools from the beginning of the 21st century enabled planners to perform a more precise analysis, and therefore more opportunities for improving the acoustics of the space. One of the architectural characteristics of the rooms is the sound quality, which is important when it comes to performance halls such as theaters and concert halls. The problem lies in striving to improve existing performance halls, whose acoustic parameters are unknown. In order to adequately improve the acoustic characteristics of the space, designers must first of all master the tools for checking the existing state of acoustic quality. By acoustic characteristics, we mean first of all the reverberation time, that is, the time for which the sound level drops by 60 dB, after the sound source is turned off. The optimal reverberation time, for different types of performance, ranges from 0.6 - 2.2 s (Figure 1) [1-3]. Existing facilities face the problem of multi-functionality. Despite the fact that different performances require certain acoustic parameters, in practice different types of musical and speech events are held in the same hall [4]. In order for the existing halls to be used for different types of performance with optimal acoustic quality, it is necessary to optimize the reverberation time with acoustic interventions in the space.

The first step in the process of improving acoustics is the determination of the current state, that is, the experimental measurement of the reverberation time in the space. For the experimental measurement of reverberation time in space, measuring instruments consisting of a sound source, a microphone and a sound analyzer that connects them and is used for data processing are most commonly represented [5]. Practice has shown that in addition to the high price of such equipment, its use is complex and requires professional training of personnel for handling. With the desire to simplify the process of experimental measurement, simpler measuring devices as well as mobile applications with the possibility of measuring the reverberation time in space appear on the market. For this reason, as part of this work, an experimental measurement of the reverberation time of the performance hall of the National Library in Čičevac was carried out with the help of the mobile application "Buzzi-Space".

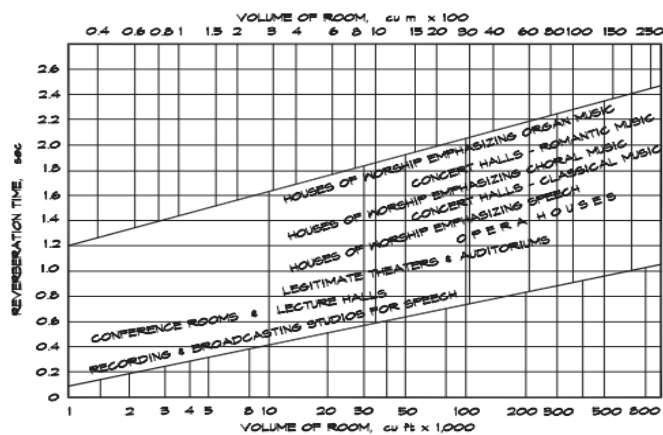


Figure 1. Optimal reverberation time for different types of artistic performances according to Long (Long, 2006, p.586)

Quality control of experimental measurement was determined by comparative analysis with reverberation time results obtained by software modeling using Odeon and Rhinoceros tools. Using the Rhinoceros tool, a software model of the performance hall was created based on the existing condition, and then an acoustic simulation was performed using the Odeon tool. Based on the results of comparative analysis of reverberation time obtained by experimental measurement and software modeling, the reliability of the "Buzzi-Space" application was tested.

After determining the existing acoustic parameters of the space, an analysis of the possibility of interventions in the space was performed with the aim of optimizing the reverberation time for multi-purpose use. Verification of the impact of architectural intervention on reverberation time was also checked using the software simulation method of the Odeon tool. With this research, the possibilities of improving the acoustics of the existing performance hall were examined, and at the same time, the possibilities of the application for experimental measurement of reverberation time were also examined.

## 2. MENTAL MEASUREMENT OF REVERBERATION TIME

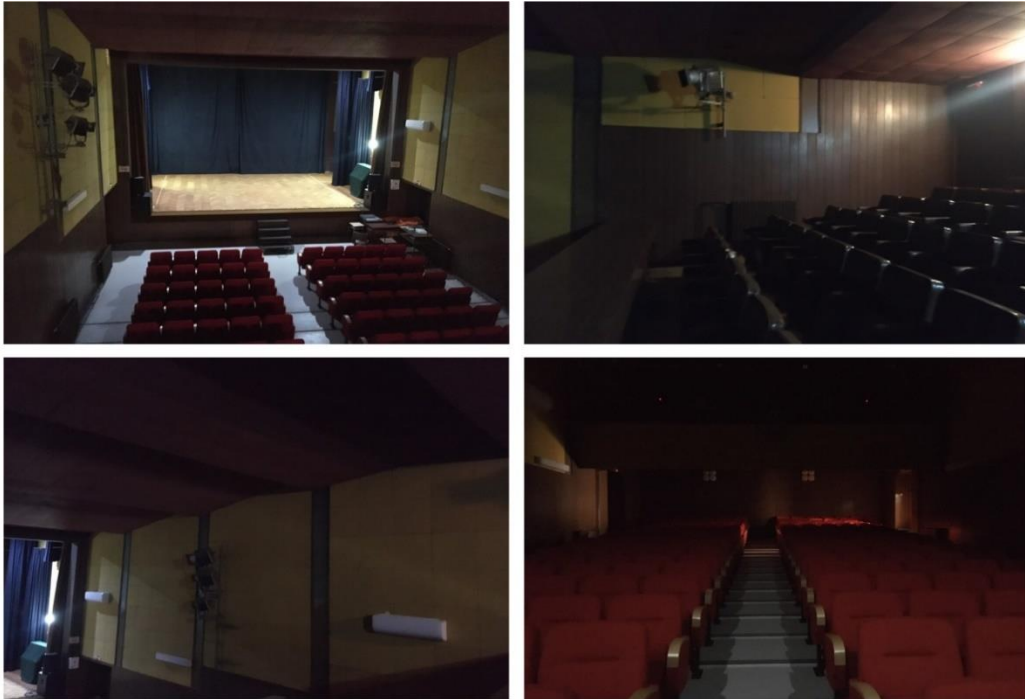
One of the main indicators of the acoustic quality of a room is the reverberation time. The duration of the reverberant sound depends on several parameters, such as the volume of the room, the absorption coefficient of the material in the interior, the area of the interior surfaces and the diffusion coefficient of the surfaces, which is determined by the geometry. Through interventions in the space, we can subsequently influence the reverberation time, namely: by changing the volume (most often the height) of the room, covering the surface in the interior with materials of different absorption characteristics and/or implementing elements of dynamic geometry [1, 6]. In the past, a numerical calculation method using Sabin's equation (Equation 2.1.) was used to calculate the reverberation time. Nowadays research has determined that the calculation using Sabin's equation, which includes only parameters such as volume, absorption coefficient and surface area of elements in the interior, does not give sufficiently precise results. For this reason, the most reliable method is the experimental measurement of reverberation time in space.

$$RT_{60} = \frac{0.161 \cdot V}{\sum_{i=1}^n a_i S_i} \quad (2.1.)$$

RT<sub>60</sub>-reverberation time (s); V-space volume (m<sup>3</sup>);  $a_i$ -absorption coefficient of the material used to cover the surface of the surface  $S_i$  (m<sup>2</sup>)

For the purposes of the research, an experimental measurement of the reverberation time of the performance hall of the National Library in Čičevac was carried out. The „box-shaped“ hall basically has an area of 25.15 x 9.0 m<sup>2</sup>, while the height varies due to the curvature. The capacity of the hall is designed for 202 spectators, 142 seats on the ground floor and 60 on the balcony. The volume of the space is 1618.4 m<sup>3</sup>. The materialization of the surface in the interior, which has a great influence on the reverberation time in the space, is as follows: the ceiling and the upper part of the walls (approximately above the height of 220 cm) of the auditorium are lined with styrodur panels of high absorption power; the lower part of the walls of the auditorium (below the height of approximately 220 cm) is lined with wooden paneling; the auditorium floor has a linoleum finish; the walls surrounding the stage are made of brick with a layer of plaster and partially covered with cloth

drapes; the podium of the stage is lined with wooden parquet; the ceiling of the stage has a final treatment in the form of a layer of plaster on the ceiling structure (Figure 2).



*Figure 2. Interior of National library performance hall in Čičevac, Serbia*

Within this chapter, the experimental measurement of the reverberation time was carried out with the help of the "Buzzi-Space" application, which is owned by the company of the same name, which is engaged in the production of panels for the acoustic treatment of spaces. The use of the application would significantly speed up and make the process cheaper because the measurement is done through a free mobile application, without the need for expensive equipment and professional staff. In addition to the mobile application, inflatable (air) balloons are necessary for testing purposes. The measurement process takes place by, after activating the mobile application, we pop a balloon at a distance of no less than 1 m from the microphone on the mobile device. It is necessary that during the measurement there is complete silence in the room, i.e. that the sound produced by the puncturing of the balloon is the only sound in the room [7]. During the measurement, the position of the device was such that the microphone of the mobile device was 7 m away from the stage in the auditorium area, centrally positioned in width (4.5 m from the side walls) and at a height of 1.5 m, while the balloon (source of sound) was 1 m away from the microphone in the direction closer to the stage. Three measurements were made at the described position. The measurement was performed in octaves for frequencies from 125 to 4000 Hz.



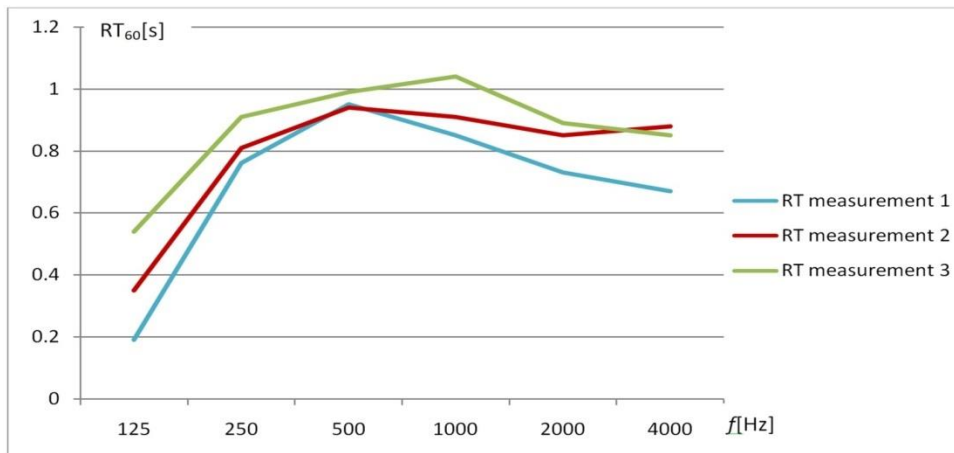


Figure 3. Reverberation time results - experimental measurement with "Buzzi-Space" application

Based on the experimental measurement results shown in the graph (Figure 3), we can notice that the reverberation time increases by approximately 0.5 s with increasing frequency from 125 Hz to 500 Hz, and then decreases by approximately 0.1 s with increasing frequency from 500 Hz to 4000 Hz. From the graphic, we can notice that the biggest deviations of the results are during measurements at low frequencies (125 Hz), which leads to the assumption that there was an error in the measurement. Deviations in measurements at the frequency of 125 Hz amount to approximately 0.4 s, while at higher frequencies the difference in measurements is smaller and does not vary by more than 0.1 s. At higher frequencies (4000 Hz), there is again a greater deviation in the experimental measurement results, but in this case the deviation is less than 0.2 s.

### 3. ANALYSIS BY SOFTWARE MODELING

In order to check the quality of the experimental measurement method, described in the previous chapter, a simulation of the room acoustics was performed using the software modeling method using the Odeon tool. The application of "ray-tracing" and "hybrid" methods made possible the high precision of predicting the acoustics of the space of the Odeon tool. The application of the mentioned methods leads to the generation of secondary sound sources at the point of sound wave reflection. Algorithms enable the calculation of the share of diffusely reflected, directly reflected and absorbed sound at each contact with surfaces in the interior [8-10]. The introduction of the geometry parameter contributed to a more accurate software simulation of room acoustics [11].

The software simulation of acoustics was preceded by the modeling of the space using the Rhinoceros tool in terms of dimensions and materialization, which was found to be the existing state of the performance hall of the National Library in Čičevac (Figure 4). The dimensions of the hall and materialization are described in the previous chapter. The measuring instruments in the software simulation are provided in the same positions as in the experimental measurement. The reverberation time is calculated by octaves in the frequency range of 62.5 – 8000 Hz.

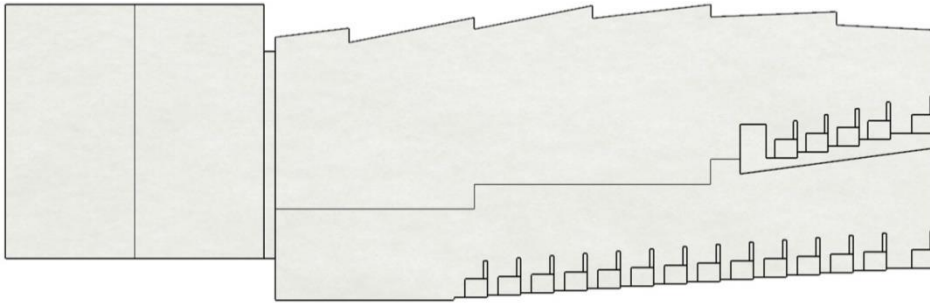


Figure 4. Longitudinal section National library theater Ćičevac

The reverberation time of the existing condition of the performance hall of the National Library in Ćičevac, obtained by software modeling using the Odeon tool, is shown in the graphic (Figure 5). On the graph, we can see a slight increase in the duration of the reverberant sound with increasing frequency from the initial 62.5 Hz to 1000 Hz. Frequency growth over 1000 Hz results in a linear decay of the reverberation time. The materialization of the interior has the greatest influence on the changes in reverberation time by frequency.

By comparing the reverberation time results obtained by experimental measurement and the software simulation method, the quality check of the "Buzzi-Space" application was performed. The results of the comparative analysis point to large deviations in the reverberation time at low frequencies. At a frequency of 125 Hz, the reverberation times obtained by measurement and software simulation differ by more than 0.5 s. At higher frequencies (from 250 – 4000 Hz) there are no major deviations in the results. Apart from the greater difference in the reverberation time result at the frequency of 125 Hz, we can say that at higher frequencies there are no greater deviations of the results due to the fact that there is no difference greater than 0.1 s.

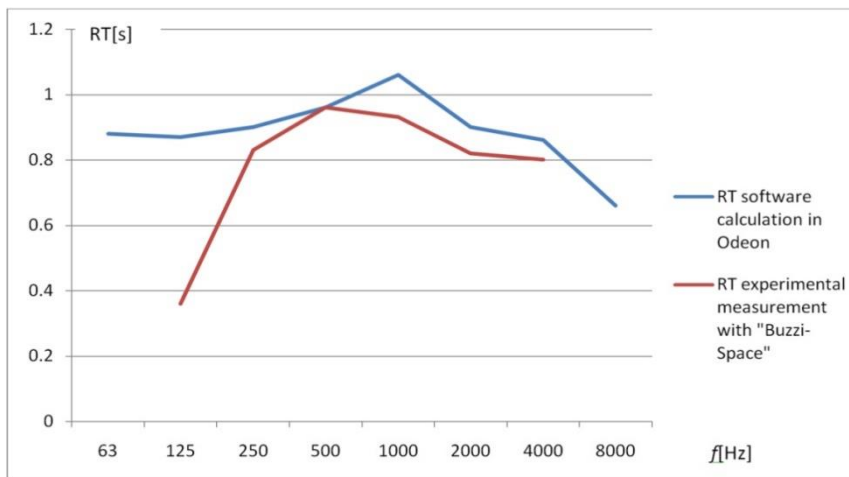


Figure 5. A comparative analysis of reverberation time results – software simulation and experimental measurement

The current state of the room's acoustics, with a short reverberation time, is suitable for speaking engagements and theater performances. Through the

suggestions of the users of the performance hall, the desire for multi-purpose use of the space was expressed. Multifunctionality in this case would mean the possibility of using the hall for both theatrical and various musical performances, with optimal acoustic comfort. As different musical events require a significantly longer reverberation time compared to public speaking and theatrical performances, it is necessary to extend the reverberation time through interventions in the space. The optimal value of the reverberation time could be defined as a suggested borderline value between theatrical and musical performance. Desirable values for theaters range between 0.8 - 1.2 s, while for musical performances this limit is between 1.4 - 2.2 s. The optimal time for multi-purpose use of the hall can be defined within the limits of 1.2 - 1.4 s.

In order to improve acoustics for multifunctional use, it is necessary to carry out interventions that will lead to a longer reverberation time. Analyzing the existing situation on the field, the simplest form of intervention was the removal of Styrodur panels from the upper parts of the walls of the auditorium. By removing a panel with a high absorption coefficient, a wall remains with a layer of plaster with a significantly lower absorption coefficient (Figure 6). The impact of removing the styrodur panels from the walls of the hall is predicted by software simulation using the Odeon tool. The simulation results indicate that the dismantling of the panel will increase the reverberation time in the frequency range of 62.5 - 4000 Hz by approximately 0.4 s (Figure 7). For frequencies below 1000 Hz, the reverberation time ranges between 1.2 and 1.4 s, which we previously defined as desirable values. As the frequency increases above 2000 Hz, the reverberation time values begin to drop sharply. The simulation results suggest that removing the styrodur panels from the walls of the auditorium can allow the reverberation time to be at optimal values for the multipurpose use of the hall.

63 Hz	125 Hz	250 Hz	500 Hz	1000 Hz	2000 Hz	4000 Hz	8000 Hz
0.70000	0.70000	0.86333	0.77333	0.54333	0.21667	0.20667	0.20000

63 Hz	125 Hz	250 Hz	500 Hz	1000 Hz	2000 Hz	4000 Hz	8000 Hz
0.01000	0.01000	0.01000	0.01000	0.02000	0.02000	0.02000	0.02000

Figure 6. Absorption coefficients - Styrodur panels (upper); Brick wall (down)

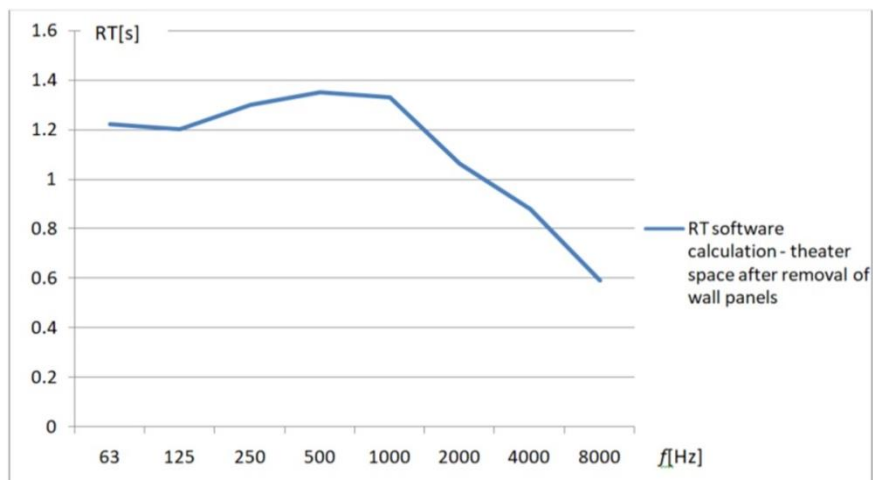


Figure 7. Prediction of reverberation time after intervention - calculated in Odeon

## 4. CONCLUSION

Within this work, an analysis of reverberation time results obtained by experimental measurement and software modeling was performed. For the purposes of the research, the reverberation time was measured in the performance hall of the National Library in Čičevac, while the condition recorded in the field enabled the creation of a software model for acoustic analysis. In order to examine the acoustic characteristics of the space, it is necessary to use an adequate tool. For this reason, the aim of this research was to examine the precision of experimental reverberation time measurement using the "Buzzi-Space" mobile applications, as well as the possibilities of improving acoustics with minimal interventions in the space examined by the software modeling method.

Comparative analysis of reverberation time results, obtained by experimental measurement and software modeling, lead to the conclusion that measurement using the "Buzzi-Space" application gives reliable results at frequencies higher than 125 Hz. The deviation in reverberation time at frequencies higher than 125 Hz is not greater than 0.1 s, which we can consider negligible. At a frequency lower than 125 Hz, the deviation of the results is greater than 0.5 s, which is why we cannot consider measurements at these frequencies to be sufficiently precise. The results indicate that the use of the application is suitable for conceptual design of room acoustics and commercial use, but not for research measurements that require greater precision at all frequencies.

In order to improve the hall for multifunctional use, a comparative analysis of the results of the reverberation time of the existing state and the state after the proposed intervention in the space was performed, using the software simulation method. The desire to reduce interventions in the space to a minimum, led to the simulation of the simple removal of styrodur panels (high absorption coefficient) from part of the walls of the auditorium. Based on the results of the software simulation using the Odeon tool, we can conclude that the intended intervention would lead to the creation of an optimal reverberation time for the multipurpose use of the performance hall.

## REFERENCES

- [1] Barron Michael, Auditorium Acoustics and Architectural Design, *Spon Press*, UK, 2010.
- [2] Long Marshall, **Architectural Acoustics**, *Elsevier Academic Press*, London, UK, 2006. pp. 615; 656.
- [3] Kuttruf Heinrich, **Room Acoustics**, *Spon Press*, London, 2000. pp. 615; 656.
- [4] Apploton Ian, Building for the Performing Arts, A design and Development Guide, *Architectural Press*, UK, 2008.
- [5] Vasov Mimir, Cvetković Dragan, Bogdanović Veliborka, Bjelić Igor, **Assessment of Reliability Predictions of the Reverberation Time by Using the Architectonic Software Package Ecotect**, *Facta Universitatis*, Vol. 15, No.3, 2017. pp. 359-370.
- [6] Cox Trevor, D'Antonio Peter, **Acoustic Absorbers and Diffusers**, *Spon Press*, London, 2004.
- [7] <https://www.buzzi.space/> (28.06.2023.)
- [8] Vorlander Michael, **Computer Simulation in Room Acoustics: Concepts and Uncertainties**, *Acoustical Society of America* 133, 2013. pp. 1203-1213.

- [9] Šumarac-Pavlović Dragana, Petrović Milan, **Influence of Diffusivity in Room on its Acoustic Response**, *Telfor Journal*, Vol.2, No.2, 2010. pp 92-97.
- [10] Gomes Helder Rodrigues Mario, Vorlander Michael, Gerges Samir, **Measurement and Use of Scattering Coefficients in Room Acoustic Computer Simulations**, *Acustica*, Portugal, 2004.
- [11] Odeon User's Manual <https://odeon.dk/download/Version17/OdeonManual.pdf>  
(16.9.2022.)

# POSSIBILITIES OF ABSENTEE LEARNING IN ARCHITECTURAL DESIGN

Nikolay Istatkov <sup>1</sup>

## ABSTRACT

*The rapid development of information and computer technologies together with the COVID pandemic in recent years have brought to the fore the need for the increasingly frequent and intensive use of absentee learning in architectural design.*

*The conflicting reviews and evaluations of the results of the various Absentee learning forms determine the need for a deeper analysis, both opportunities they provide, as well as the need to improve the conditions and material base for their effective application.*

*The report presents a study of the practical application of absentee learning in architectural design.*

*Examples of completed student projects, because of Absentee learning, are analyzed.*

*As an integral part of the research, the existing specific software products enabling the implementation of the absentee online educational process are included, namely: video-conferencing platforms MS TEAMS, ZOOM, WEBEX, INTERMEDIA ANYMEETING, GOOGLE MEET, RING CENTRAL and others, social networks and channels for communication - FACEBOOK, VIBER, WHATSAPP, MESSENGER and others, as well as software products for remote access such as TEAMVIEWER, ANYDESK, REMOTE PC and others.*

*The conclusions of the research, according to the author's opinion, unequivocally indicate that, despite the shortcomings and the natural objective contradictory reaction of a large part of the participants in the educational process, the accelerated adaptation and proactive application of absentee online learning in architectural design are a prerequisite and a mandatory condition for sustainable development of the educational process for the future.*

**Key words:** *Absentee learning, Architectural design, Information technologies, Computer technology*

---

<sup>1</sup> Arch., Senior Assist. Prof. Nikolay Istatkov, University of architecture, civil engineering and geodesy, nistatkov\_far@uacg.bg

## **1. INTRODUCTION**

The dynamics and intensity of the modern way of life in recent years has increasingly emphasized the extreme importance and importance of time as a priceless resource. It is for this reason that remote and electronic services occupy an increasingly significant and large share in most spheres of life. Architectural design education is no exception, and its absent form is becoming increasingly popular and frequently used.

The rapid pace of development of information, communication and computer technologies allows the increasingly effective and mass application of non-present learning in architectural design.

## **2. RELEVANCE OF THE TOPIC**

The topicality of the topic is related both to the above-described trends in the modern world and to the COVID 19 pandemic, which unequivocally showed the need for more effective and more adequate non-present forms of learning in general and related to architectural design.

The COVID 19 pandemic has forced the governments of many countries around the world to introduce restrictive measures and close universities and schools to limit the spread of the infection. According to UNESCO's estimate, more than 1.5 billion students and pupils from 165 countries had to stay at home [1], causing a collapse of the education system worldwide.

To overcome the ensuing unprecedented crisis in education, governments, universities, and schools joined forces to move to various forms of Absentee learning, enabling students and pupils not to interrupt their education and continue learning quickly and effectively from home.

## **3. DEFINITION AND HISTORY**

Absentee learning, defined as a form of learning where a student and teacher are separated in time and space or both [2], has been used for more than 100 years [3], although many people associate Absentee learning only with the COVID pandemic 19. In fact, it served as a kind of catalyst for its mass application worldwide.

Absentee training can be divided into two main groups: synchronous, asynchronous [4].

Synchronous learning means that communication between teacher and students takes place at the same time, i.e., synchronously. Synchronous Absentee learning is like classroom teaching, although the tutor and students are physically separated in space. An advantage of the synchronous type of non-attendance training is the direct communication between the teacher and students and the possibility of receiving answers to relevant questions in real time.

The asynchronous Absentee learning mode means that students have access to learning materials at any time and the presence of the teacher is not necessary. A typical example of asynchronous online Absentee learning is WEB-based learning accessible 24/7 (24 hours/7 days a week) via the Internet from anywhere in the world. An advantage of the asynchronous method is the students' freedom in choosing the time to participate in the learning process.

The two types of absentee learning - synchronous and asynchronous - can be successfully combined within one course or discipline to take advantage of the advantages of both types. [5]

The idea of Absentee learning dates to the nineteenth century, when communication between students and teachers was done by mail, which offered a cheap way to transmit information over long Absentees at that time [4]. The training itself is implemented in the following way: the teacher sends educational materials (lectures, instructions, tasks to students by mail, the students, in turn, also return the completed tasks by mail to the teacher, who corrects, evaluates, and sends back the results of the completed work to the participants in course [6].

One of the first examples of the implementation of Absentee learning by mail was training in shorthand, implemented by Isaac Pitman in Great Britain as early as 1840. The University of London, for its part, claims to be the first university, which already in 1858 offered a complete program for Absentee learning with issuing diplomas. This has been developed and currently offers several International University of London programs including postgraduate qualifications, bachelor's, and master's degrees, delivered by colleges such as the London School of Economics, Royal Holloway, and Goldsmiths.[4]

A key stage in the development of Absentee learning occurs with the rapid development of information, computer, and communication technologies, and above all the Internet. Absentee learning using the Internet has received the term Absentee online learning [7]. It uses a wide range of modern information technologies available via the Internet: WEB sites with educational materials [8], video conferences, social networks, and applications for communication between students and teachers. This stage can rightly be called the era of absentee online learning.

Absentee education in architectural design is specific, requiring a continuous relationship between teacher and student, which determines its application only as an additional form to traditional on-site education.

#### **4. TERMS AND CONDITIONS OF APPLICATION AND PRACTICE**

One of the main conditions for the application of absentee online learning in architectural design is the availability of electronic communication devices (personal computers, tablets, mobile smart phones) for both students and teachers.

A variety of video conferencing platforms and technologies such as MS TEAMS, ZOOM, WEBEX, INTERMEDIA ANYMEETING, etc. are used to implement non-present online learning. Synchronous learning using video conferencing requires the teacher to develop a schedule of lectures and exercises, by analogy with the traditional face-to-face teaching at the university, and by the students recording and joining via video conference the given lecture or exercise at the precisely indicated time – Figure 1.



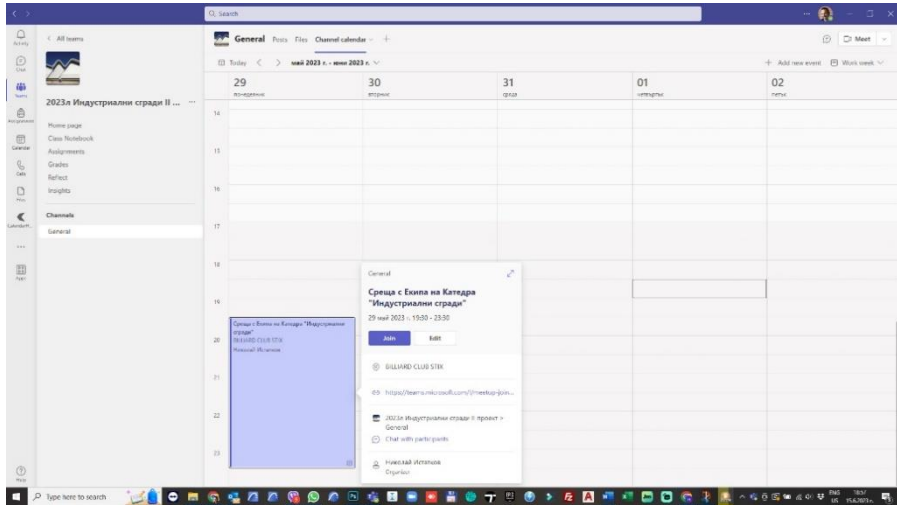


Figure 1. MS Teams – Calendar, author's archive

At the University of Architecture, Construction and Geodesy – Sofia, Bulgaria (UACEG) Microsoft Teams is used as the main software product since it was chosen by the Bulgarian Ministry of Education and Science (MES) as a platform for video conferencing in Absentee learning during the COVID- 19 pandemic. The Ministry of Education and Culture has created free profiles of teachers, students, and pupils to be used for the implementation of Absentee learning.[9]

Video conferences are held in real time and to save the content for review MS TEAMS offers the MS RECORD feature – Figure 2. Experts affirm that an hour after the specific lecture, the student remembers half of the material, after 24 hours no more than 33%, and after a week about 20%, provided that two days after the lecture he does not review and discuss the material [10]. This is precisely why the ability to record is key in absentee learning in architectural design.

The tutor, as well as any of the students participating in the respective video conference, can record lectures using MS RECORD and then download them locally as mp4 files that can be viewed later.

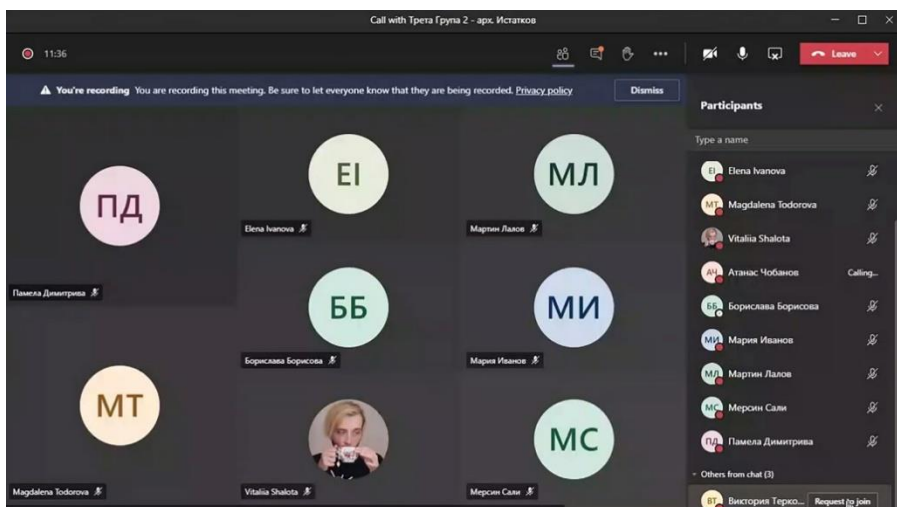


Figure 2. MS Teams – Video Conference, author's archive

The MS TEAMS platform of the IT giant Microsoft is a very good software product offering many features, and their full mastery requires time and effort. For this reason, many teachers not only in Bulgaria, but also in the USA, the homeland of Bill Gates himself and the IT giant Microsoft, prefer to use alternative video platforms for organizing video conferences for absentee online learning.

The most popular MS TEAMS alternative is the Zoom video platform – Figure 3. Like MS TEAMS, ZOOM uses cloud technologies (cloud-based video conferencing service) to implement a video conference connection. Cloud technologies record the lectures given during the video conference on the cloud-based server. ZOOM, however, also has an option to record lectures to a local disk in mp3 format.

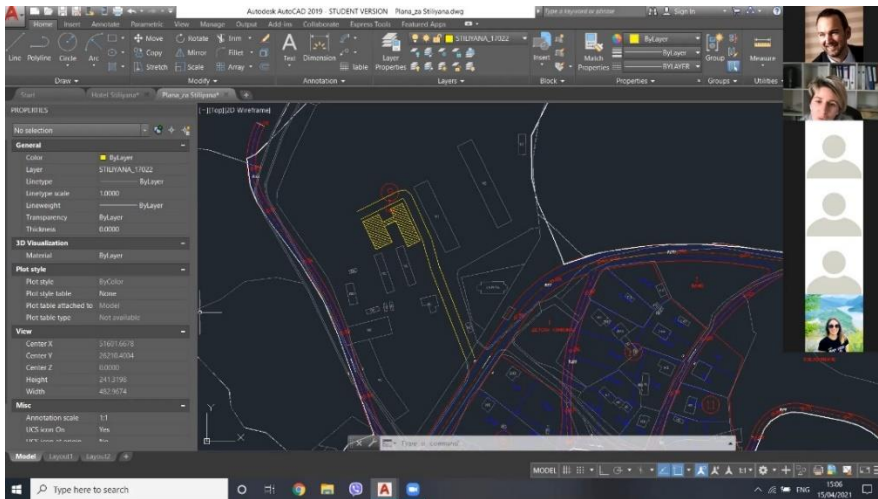


Figure 3. Zoom – Video Conference, author's archive

The free version of ZOOM has limited capabilities – up to 100 students in a video conference and up to 40 min session duration. For an unlimited session, a paid version of ZOOM is required. Although the basic functions of MS TEAMS and ZOOM, such as organizing video conferences, recording lectures, reviewing lectures, downloading/uploading lectures using cloud technologies, are similar, ZOOM's interface is clearer for the user (user friendly interface). This is the main reason why some teachers in Bulgaria, including the UACEG, prefer using ZOOM instead of MS TEAMS, despite additional financial costs for the paid version.

For better and timely communication with his students during the Absentee learning of architectural design, the author also uses social networks such as FACEBOOK, VIBER, WHATSAPP and others, as well as remote access application TEAMVIEWER, ANYDESK, REMOTE PC. and others. Through TEAMVIEWER, the teacher could review the completed work of the student and directly answer his questions in online communication mode.

## 5. PRACTICE RESULTS

As a result of the practice of Absentee learning in architectural design, completed student projects in the discipline of Agricultural Buildings at the University of Architecture, Construction and Geodesy (UACEG), prepared by students 3rd year 5th semester, have been presented and analyzed. The requirements for the project

development were to express the personal attitude of the student (author) to the problems that arise in the design process and are related to the relations building - external environment, building - technology, building - construction, building - working environment. Appropriate choice of structural system. Also, the project had to comply with the main requirements for sustainability and the creation of "green architecture", the main goals of which are: the formation of a high-quality working environment, a conflict-free entry of the new object into the existing environment, optimal use of the resources of the site , energy efficiency – compactness of the spatial structure, possibility of disassembly and reassembly in another place, etc. The graphic and text materials are provided by the archive of the electronic platform to the WEB site of the UACEG [11]

Example 1: Wine Cellar – Figure 4, Figure 5 and Figure 6



Figure 4. Wine Cellar – Master plan, <https://e-learn20.uacg.bg/>

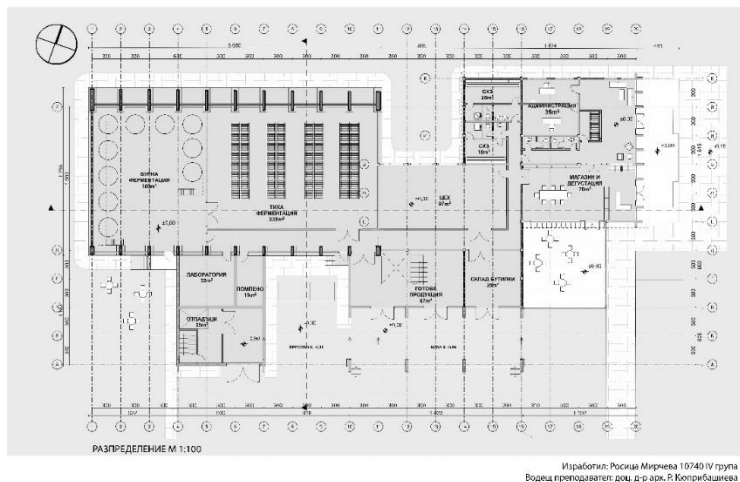


Figure 5. Wine Cellar – Floor plan, <https://e-learn20.uacg.bg/>



Изработил: Росица Мирчева 10740 IV група  
 Водец преподавател: доц. д-р арх. Р. Кюприбашиева

Figure 6. Wine Cellar – Visualizations, <https://e-learn20.uacg.bg/>

The presented example was evaluated with an excellent rating, as the project was developed in completeness and content illustrating the student's capabilities and presenting the knowledge he acquired during the absentee online training in architectural design of Agricultural buildings. The lead teacher and the student were able to communicate well, despite the lack of face-to-face meetings and corrections, which led to an excellent development result. This and similar examples unequivocally prove that with good will, diligence, and a serious attitude towards the work of a student and teacher, high-quality and valuable architectural projects can be created even with an absent form of architectural design.

Example 2: Equestrian tourism base – Figure 7, Figure 8 and Figure 9

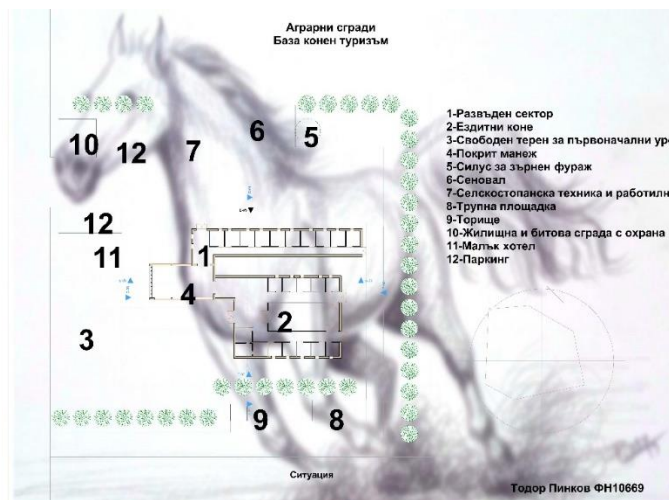


Figure 7. Equestrian tourism base – Master plan, <https://e-learn20.uacg.bg/>

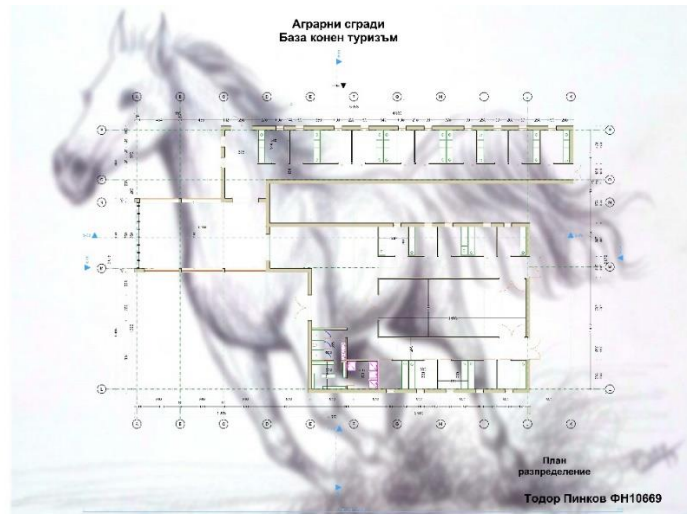


Figure 8. Equestrian tourism base – Floor plan, <https://e-learn20.uacg.bg/>

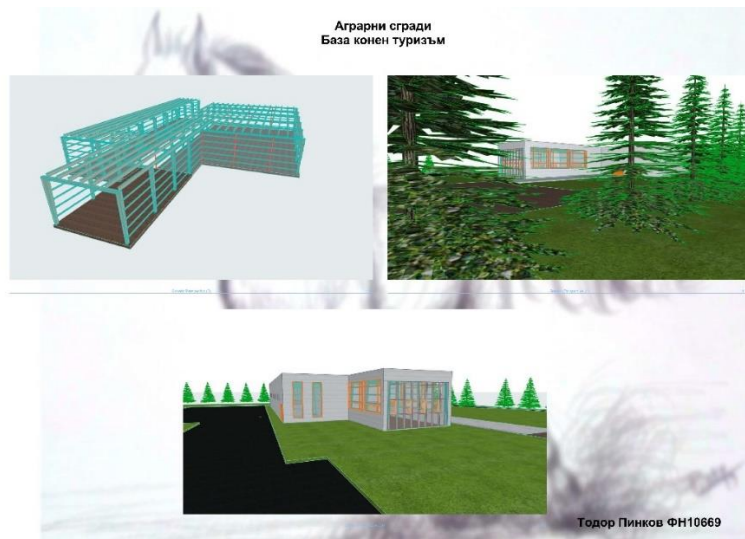


Figure 9. Equestrian tourism base – Visualizations, <https://e-learn20.uacg.bg/>

The presented example was assessed with an average grade, as the project development shows the student's frivolous attitude in volume and content, covering the minimum requirements of the task on the edge. The lack of regular participation in the exercises, the insufficient attention and desire on the part of the student during the absentee training have also led to this unsatisfactory development result. This and similar examples show that in case of reluctance and insufficient dedication to the project on the part of the student, regardless of the efforts made by the leading teacher, the result of absentee training in architectural design can be extremely unsatisfactory.

## 6. ADVANTAGES AND DISADVANTAGES

The advantages and disadvantages of Absentee learning in architectural design are presented in a tabular form for a clearer and clearer view.

Table 1. Advantages and Disadvantages of Absentee Learning

Category	Advantages	Disadvantages
<i>1. Perception</i>		
<i>Software</i>	<i>Using different types of software products enabling a huge range of presentation formats. Launch of BIM software, including the creation of interactive three-dimensional models and virtual reality</i>	
<i>Graphic technique</i>		<i>Difficult to build a quality graphics technique, using only a mouse</i>
<i>Editing</i>	<i>fast editing</i>	<i>More difficult and less intuitive editing.</i>
<i>2. Duration</i>	<i>Saving time on transportation to and from the university</i>	
<i>3. Conducting time</i>	<i>Flexibility in planning and conducting exercises</i>	
<i>4. Feedback</i>		<i>There is no direct and fruitful communication with the student</i>
<i>5. Control</i>	<i>Accurately refine the date and time of transmission</i>	<i>Lack of quality control regarding student attention and commitment</i>
<i>6. Accessibility</i>	<i>Extremely great freedom, practically without restrictions regarding the location of the teacher and the student, the only necessary condition being the presence of an electronic device for communication (Computer, tablet, smartphone)</i>	<i>The presence of electronic is mandatory. communication device (personal computer, tablet, mobile smart phone)</i>
<i>7. A re-examination</i>	<i>Possibility to record the corresponding exercise and review it again</i>	<i>Students rely on recording and are prone to be careless</i>
<i>8. Variation</i>	<i>The virtual environment of the specialized software enables multiple solution options</i>	<i>With inexperience, there is a possibility of confusion between many options</i>

## 7. CONCLUSIONS

One of the main conclusions concerns the unequivocal advantages - the economic benefits, the saving of time resources and the possibility of practically unlimited access through the Internet, namely that in view of the mentioned three significant factors, Absentee learning becomes one of the main forms for the future development of education in architectural design.

Attention should also be paid to the material base and the readiness of educational institutions to provide the necessary materials and electronic devices for communication, both to students and teachers, which is an important prerequisite for the effective and high-quality implementation of Absentee learning in architectural design.

The third, but no less important, conclusion also affects the psychological attitude and attitude towards the educational process, especially in architectural design, where the specific requirements for direct communication and real-time feedback determine the natural skeptical reaction of most participants to something new and different. The author's opinion is that such a reaction is natural and normal, but the formula and the way to gradually transform this negative attitude into acceptance and adaptation to absent learning in architectural design must be found.

Absentee learning gives good results while saving time and resources. Its real product, however, will be clear in 3-4 years, when there will be specialists trained in this way on the labor market.

In conclusion, the conclusions drawn from the presented research, according to the author's personal opinion, unequivocally indicate that, despite the shortcomings and the natural objective contradictory reaction of a large part of the participants in the educational process, the accelerated adaptation and proactive application of absentee online learning in architectural design are a prerequisite and a mandatory condition for the sustainable development of the educational process in the future.

## REFERENCES

- [1] COVID-19 and Higher Education: Education and Science as a Vaccine for the Pandemic. <https://www.un.org/en/academic-impact/covid-19-and-higher-education-education-and-science-vaccine-pandemic>.
- [2] Honeyman, M. & Miller, G. Agriculture Absentee education: A valid alternative for higher education? Proceedings of the 20th Annual National Agricultural Education Research Meeting (67 –73). 1993.
- [3] Doug Valentine. Absentee Learning: Promises, Problems, and Possibilities. Online Journal of Absentee Learning Administration, Volume V, Number III, Fall 2002. State University of West Georgia, Absentee Education Center.
- [4] Bušelić, Marija. Absentee Learning – concepts and contributions. *Oeconomica Jadertina*. 2. 10.15291/oec.209. 2017.
- [5] <https://www.skillsacademy.co.za/types-of-Absentee-learning/>
- [6] G. Kiryakova. Review of Absentee education. *Trakia Journal of Sciences*, Vol. 7, No. 3, pp 29-34, 2009.
- [7] Andrey Koptelov, Stephen Turne. Online education and best practices for the development of a Absentee education program. *SHS Web of Conferences* 98, 05009. 2021. Available: <https://doi.org/10.1051/shsconf/20219805009>

- [8] Mshvidobadze, Tinatin & Gogoladze, Tamar. (2012). About Web-Based Absentee Learning. International Journal of Distributed and Parallel systems. 3. 10.5121/ijdps.2012.3313.
- [9] <https://hristoterziev.com/index.php/2018-09-20-18-09-59/2020-03-18-18-02-53/822-teams-2>
- [10] <https://deveducation.com/blog/effektivnye-sposoby-zapominaniya-informatsii/>
- [11] <https://e-learn20.uacg.bg/>



## FATIGUE LIFE PREDICTION OF ADHESIVELY BONDED JOINTS BASED ON STIFFNESS DEGRADATION

Nenad Stojković<sup>1</sup>, Petar Knežević<sup>2</sup>, Nikola Velimirović<sup>3</sup>, Nemanja Marković<sup>4</sup>

### Abstract

*Adhesive bonding has become very popular and is used in almost every field of industry. However, the difficulties in predicting the long-term behavior as well as the durability of such connections is the main problem for their wider application in engineering practice. With respect to long term service life, fatigue loading is considered as one of the most important forms of loading of structural adhesive joints. In the literature, several approaches are available for predicting fatigue life of such joints. However, they are mainly based on destructive testing of a large number of samples subjected to cyclic loading until failure. In this paper, the procedure for fatigue life prediction of adhesive joints by monitoring the load displacement behavior of samples subjected to cyclic loading was presented. The stiffness degradation curves were utilized for predicting the fatigue life of the experimentally tested samples of double lap shear joint. For validating the proposed method, the comparison between the obtained predictions and experimentally obtained fatigue lives was performed. Moreover, the comparison between the obtained predictions and predictions based on the classical S-N curve approach was performed. It showed that the proposed method showed much better agreement with the experimental results.*

**Key words:** *stiffness degradation, fatigue life prediction, constant amplitude fatigue, cyclic loading*

---

<sup>1</sup> PhD, Professor of Applied Studies, Academy of Applied Technical and Educational Studies, Niš, nenad.stojkovic@akademijanis.edu.rs

<sup>2</sup> PhD, Assistant Professor, State University of Novi Pazar, Department of Technical Sciences, Civil Engineering, Novi Pazar, pknezevic@np.ac.rs

<sup>3</sup> PhD, Assistant Professor, State University of Novi Pazar, Department of Technical Sciences, Civil Engineering, Novi Pazar, nvelimirovic@np.ac.rs

<sup>4</sup> PhD, Assistant, Faculty of Civil Engineering and Architecture, University of Niš, Niš, nemanja.markovic@gaf.ni.ac.rs

## 1. INTRODUCTION

Adhesive bonding has become very popular and is used in almost every field of industry. The ease of practical operation and suitability for bonding adherends with complex geometries, as well as its ability to join dissimilar materials, low manufacturing cost, good strength-to-weight ratio, high stiffness and more uniform stress distribution are some of the advantages of adhesives when compared to traditional joining methods. However, the difficulties in predicting the long-term behavior as well as the durability of such connections is the main problem for their wider application in engineering practice. With respect to long term service life, fatigue loading is considered to be most important form of loading of structural adhesive joints [1]. Having in mind that the most of the structural systems are built to withstand against cyclic load, reliable prediction of the fatigue behavior of adhesively bonded joints under cyclic loading is of significant importance for their design.

In the literature, several approaches to fatigue are widely present: fracture mechanics approach, damage mechanics approach, total life approach, stiffness degradation and strength degradation approach. In Fracture mechanics, a pre-existing macro crack is considered to be present in the initial state and the crack growth due to influence of cyclic loading is analysed with the increasing number of cycles, without considering the crack initiation phase of joint life. In Continuum Damage Mechanics approach (CDM) the damage, on an elemental cross-sectional plane, is quantified by the surface density of cracks and cavities at that section [2]. In total life approach and strength and stiffness degradation approaches, damage metric is summed cycle by cycle, but there is no differentiation between phases of fatigue, i.e., crack initiation phase, crack propagation, and slow wear-out or sudden death. In literature, different categorizations of the fatigue approaches can be found [1,3,4]. The most common categorization is into mechanistic and phenomenological models. Mechanistic models are defined as those that quantitatively account for the progression of damage, such as fatigue crack. Phenomenological models deal with macroscopically observable properties, such as strength or stiffness, and their change during the increase of the number of loading cycles.

Phenomenological models tend to be more appropriate for structural engineering application, since they deal with more directly applicable parameters. However, the monitoring the evolution of strength and stiffness is quite different. The first implies destructive testing for obtaining only a single strength value of the specific sample after specific number of loading cycles. The latter could be monitored continuously, until the failure of the tested sample. Thus, for analyzing the evolution of the damage within the tested sample, many stiffness data points could be obtained by testing a single sample. Considering that the most of the structural engineering applications of the adhesive joints imply high-cycle fatigue in which joints survive millions of low-stress fatigue cycles [5], the large number data points could be obtained by testing the samples applying the similar fatigue loading conditions.

The experimental investigation of the change of the stiffness during the cycle loading can be obtained by testing the samples quasi-statically after it was subjected to certain number of cycles, or by continuously monitoring the load-displacement curve. In literature, when the fatigue degradation of the adhesive joints or composite materials was analyzed, in the most cases the stress-stain plot of the sample subjected to cyclic loading was analyzed [5-8]. This plot is used for obtaining the

secant modulus and evaluating its changes with the increasing number of cycles. However, the stress state of the adhesive joints is relatively complex, especially in the case of shear stress, which is the most preferable in adhesive bonding. On the other hand, the load-displacement plot can be used for analysing the fatigue behavior of adhesive joints. Moreover, it can be easily obtained and used for evaluation of the fatigue deterioration of adhesive joint on a macro level and predicting fatigue life of tested sample. In this paper, the procedure for fatigue life prediction of adhesive joints by monitoring the load displacement behavior of samples subjected to cyclic loading was presented. It was applied to predict the fatigue life of the experimentally tested samples of double lap shear joint. Afterwards, the comparison between the obtained predictions and real fatigue life was performed, as well as the comparison between the obtained predictions and predictions based on the classical S-N curve method.

## 2. DEGRADATION OBSERVED IN LOAD-DISPLACEMENT CURVES

During the cyclic loading of adhesive joint, hysteresis loop can be observed on a load displacement curve. For the case of tension-tension cyclic loading in a constant-amplitude load-controlled regime, the behavior of adhesive joint is illustrated in Fig. 1. For the specific load level  $S_{max}$ , the number of cycles to failure is referred to as fatigue life, denoted as  $N$  (Fig. 1a). Generally, the increase of the endured number of cycles is followed by the change in the load-displacement behavior. As reported in literature [5,9], several effects can be noticed on the hysteresis loop. They are illustrated in Fig. 1b. First, the hysteresis loop shifts during fatigue loading, which indicates the presence of the fatigue creep. This change is usually monitored through the average strain of the cycle,  $\delta_n$ . The other effect that can be observed is the change of the area covered by the hysteresis loop. This area illustrates the measure of the internal energy dissipation. The slope of the loop can be taken as the slope of the line that connects the loop peaks. It can be considered as a representation of the sample stiffness. The third effect that can be observed is the change of the slope of the hysteresis loop, which indicates the stiffness change of adhesive joint.

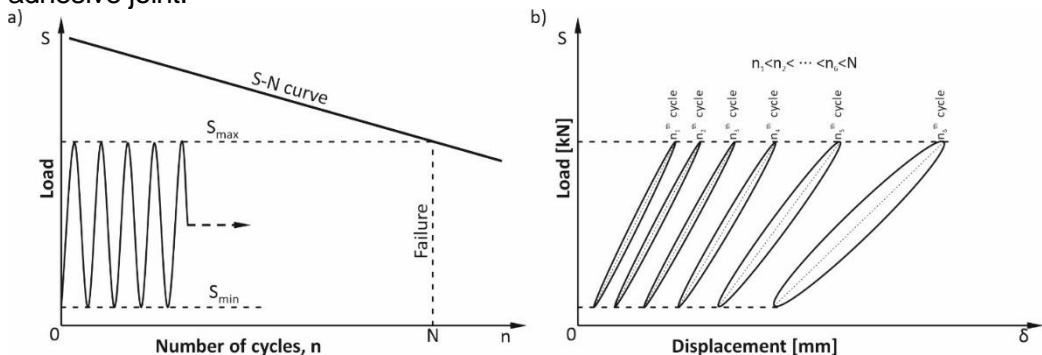


Figure 1. - Adhesive joint behaviour under cyclic loading: a) tension-tension load controlled regime b) hysteresis loop change during tension-tension cyclic loading

### 3. STIFFNESS DEGRADATION BASED FATIGUE LIFE PREDICTION

There are several models available in the literature that were developed to represent the stiffness degradation of adhesive joints with increasing number of loading cycles [10-14]. Most of these models belong to the group of so-called sigmoid functions. In [15], the author of this paper proposed Eq. 1 to represent both stiffness and strength degradation. It was later utilized to develop a method for predicting fatigue life of adhesive joints subjected to constant amplitude fatigue loading.

$$E(n) = E_0 \left[ 1 - \left( \frac{n}{N} \right)^\alpha \right]^\beta \quad (1)$$

In eq. 1  $E_0$  is the initial stiffness,  $E(n)$  is the stiffness after  $n$  cycles of loading and  $\alpha$  and  $\beta$  are curve fitting parameters. Theoretically, if the parameters  $\alpha$  and  $\beta$  are determined from the same type of adhesive joints, and the initial stiffness and stiffness at a certain number of cycles are known, the fatigue life could be determined using the following equation:

$$N = n \cdot \left[ 1 - \left( \frac{E(n)}{E_0} \right)^{1/\beta} \right]^{-1/\alpha} \quad (2)$$

However, this approach could give false predictions due to the reasons explained below.

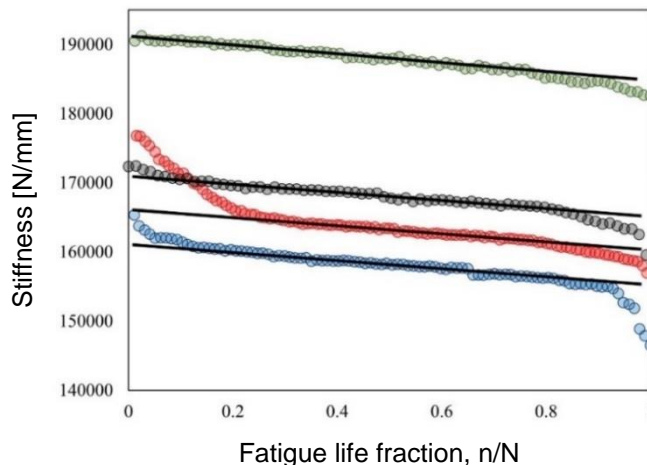


Figure 2. Stiffness degradation curves at different loading levels [12]

Analyzing the stiffness degradation curves of adhesive joints subjected to different loading levels, reported in [12] (Fig. 2), it was concluded that the initial stiffness differed from sample to sample. Moreover, a fast degradation at the beginning of the fatigue life was also different between tested samples. It was explained that the stiffness change in this region can be steep and is associated with effect of anomalies such as air pockets, air bubbles and possible impurities between the adhesive layer and the adherend or within the adhesive adjusting to a stable equilibrium state due to continual change in the stiffness. Consequently, using the values of  $E_0$ ,  $E(n)$  and parameters  $\alpha$  and  $\beta$  determined by testing similar samples can

lead to a false prediction, since the change of the stiffness in the first region could be influenced by the abovementioned anomalies.

On the other hand, it was observed in literature (Fig. 2) that the linear part of stiffness degradation with increasing fraction of fatigue life is almost parallel for all samples. This points to the conclusion that parameters  $\alpha$  and  $\beta$  can be determined by testing similar samples and the initial stiffness should be adjusted for each sample in such way that the linear parts of experimental data and prediction curve coincide. Having this in mind, a new method is developed for predicting the fatigue life of adhesive joints using experimentally obtained stiffness degradation curves during only a portion of fatigue life. It is important that this portion reaches the linear part of the stiffness degradation. The prediction procedure consists of following steps:

- 1) Static testing of multiple samples to determine the average initial stiffness.
- 2) Fatigue testing of multiple samples subjected to cyclic loading until failure. From the fatigue tests, the experimental stiffness degradation curves and fatigue lives are obtained.
- 3) Merging the stiffness degradation curves and determining the parameters  $\alpha$  and  $\beta$  by fitting the Eq. (1) to the merged data, using average value of initial stiffness (Fig. 3).
- 4) Experimentally obtaining stiffness degradation curve(s) during a certain number of loading cycles ( $n$ ) for the samples whose fatigue life is to be predicted. For fatigue life prediction of each sample, it is important that the linear part of stiffness degradation is reached.
- 5) Determination of the fatigue life of tested sample by implementing iterative fitting procedure, which is illustrated in Fig. 4. In this step, the parameters  $\alpha$  and  $\beta$  are known; initial stiffness is incrementally changed in each iteration; and fatigue life is determined in each iteration by fitting Eq. (1) to the experimental data. The iterative procedure ends when the linear parts of the experimental and prediction curves coincide. The detailed description of the iterative procedure can be found in [15].

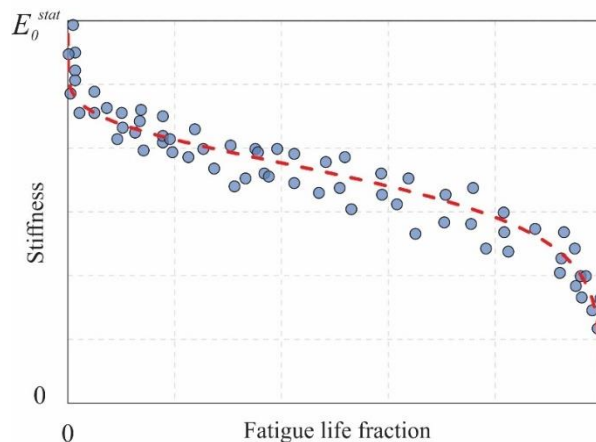


Figure 3. Determination of model parameters by fitting the prediction curve to the experimental data

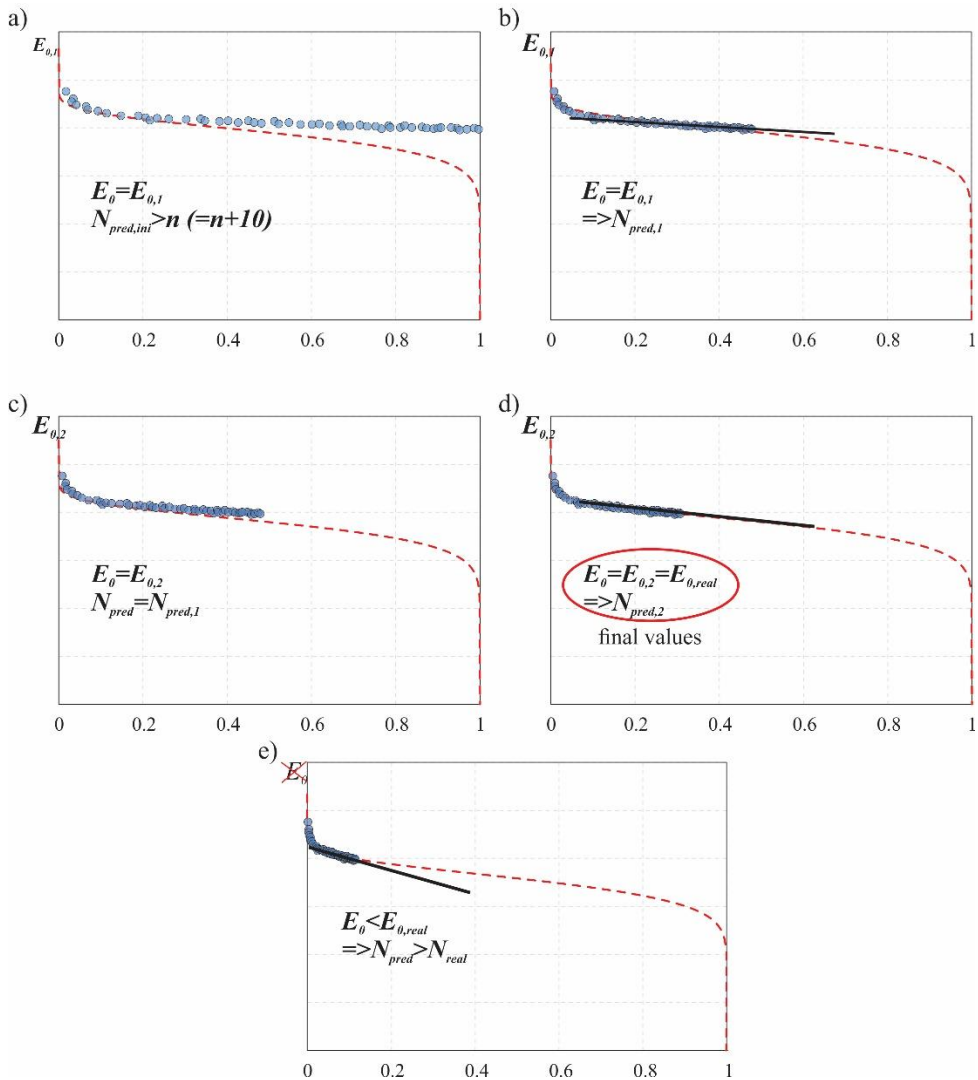


Figure 4. The iterative procedure of fatigue life prediction

#### 4. EXPERIMENTAL INVESTIGATION

The stiffness degradation of adhesive joint was experimentally investigated on a double lap shear joint with the geometry shown in Fig. 5. The joint consists of two outer plates with the thickness of 1mm, and one inner, 2mm thick adherent. All its adherends were made of galvanized steel. For bonding adherends, two component acrylic adhesive system Lord 410, with accelerator 19GB, was applied. The thickness of the adhesive layer was 1mm at each side, and it was controlled by applying 1mm thick adhesive tape on the sides of the bonding area. More details about the manufacturing of the joint, the surface preparation and curing of adhesives can be found in [15].

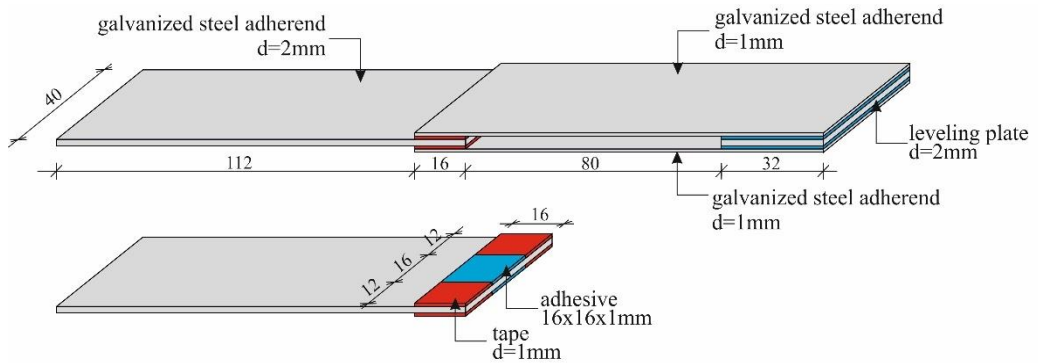


Figure 5. Geometry of the double lap shear joint

Fatigue tests were performed using universal servo-hydraulic testing machine MTS 810 with a maximum load capacity of 100kN. For measuring relative displacement between inner and outer adherends, contact extensometer HBM DDI was applied with measuring range of  $\pm 2,5$ mm and distance between measuring points of 50mm. The experimental setup is shown in Fig. 6.



Figure 6. Experimental setup

The joints were tested until failure under the constant amplitude tensile-tensile cyclic loading in load-controlled regime. The applied load ratio, i.e., the ratio between minimum and maximum load in a cycle, was  $R=0.1$ . The tests are conducted at the frequency of 5 Hz. The recording of the signal was performed using a multichannel data acquisition system Hottinger Baldwin Messtechnik MGCplus with modules ML01B and ML55B. During the cyclic loading, the load value and extensometer displacement was recorded. Since all the samples were tested with load intensities chosen to result in high-cycle fatigue, in which samples survive more than  $10^4$  cycles, continuous monitoring of the fatigue behaviour applying high data acquisition sampling rates would result in large number of data points.

## 5. RESULTS AND DISCUSSION

Quasi static tests were used for obtaining joint strength and initial stiffness, as well as deciding about the loading level of the fatigue life tests. The mean value of the obtained quasi-static shear strength of the joint was 9.64kN. For determination of the fatigue life curve, nine samples were tested at three different levels, with the maximum load corresponding to 62%, 52% and 41% of the quasi-static strength. During the test, load-displacement behavior was monitored and recorded. Two different methods were applied for prediction of the fatigue life of adhesive joints. First, maximum likelihood method [16] was applied for obtaining S-N curve from the experimental data. It is shown in Fig. 7, together with the curves that correspond to the 5% and 95% survival probability, with the confidence interval of 90%.

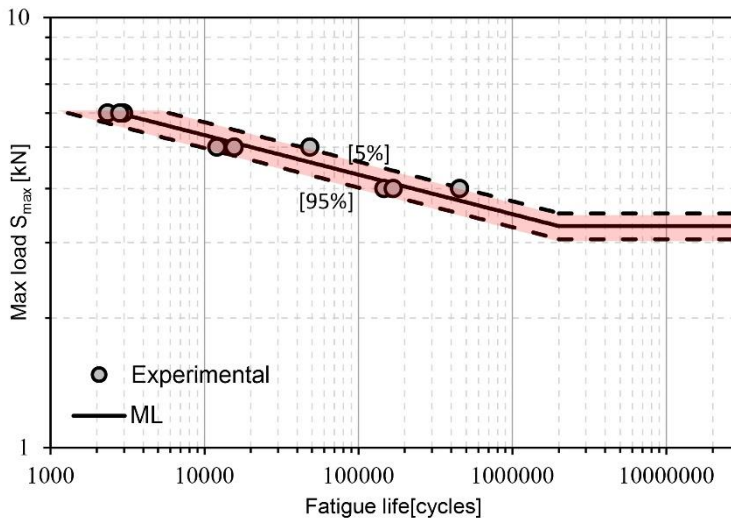


Figure 7. Fatigue life curve

In the second stage, three samples were used for obtaining stiffness degradation curve parameters by fitting eq. 1 to the experimental data. The obtained curve is shown in Fig. 8.

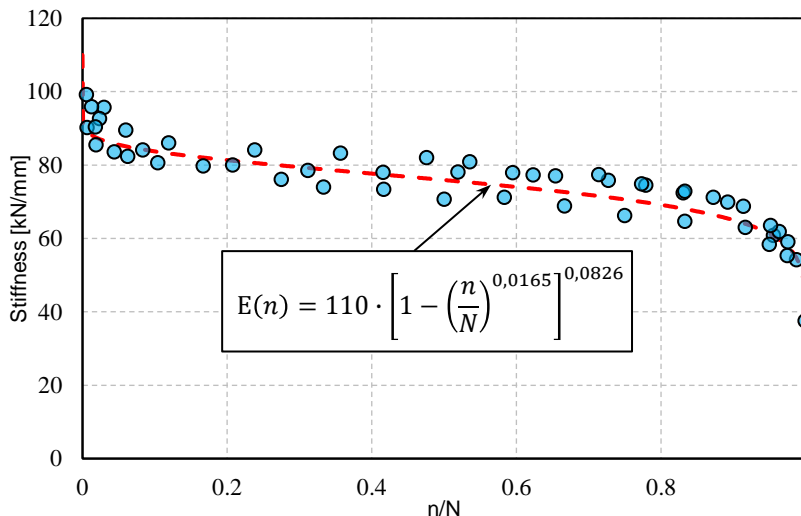


Figure 8. Stiffness degradation curve with corresponding model parameter values



In the third stage, the fatigue lives of the remaining 6 samples were determined by applying the iterative procedure illustrated in Fig. 4. The complete set of experimental results is available in [15]. Here, the fatigue life predictions of the sample that survived the largest number of cycles is presented. The sample was subjected to the cyclic loading level of 4kN and survived 452722 cycles. Since its fatigue life is known, and the load-displacement behavior was monitored continuously during the entire loading process, a large number of experimental data points were available. In order to simulate periodical inspection of adhesive joint through the determination of stiffness values, one stiffness value was taken at each 10000 cycles. Bearing in mind that a certain number of stiffness values corresponds to the specific portion of the fatigue life that is not known at the moment of the fatigue life prediction, three different fatigue life portions were analyzed in order to determine the influence of the monitoring duration on the prediction results, namely 22%, 31% and 44% of the observed fatigue life of the sample. The predicted stiffness degradation curves together with the predicted fatigue lives are shown in Fig 8.

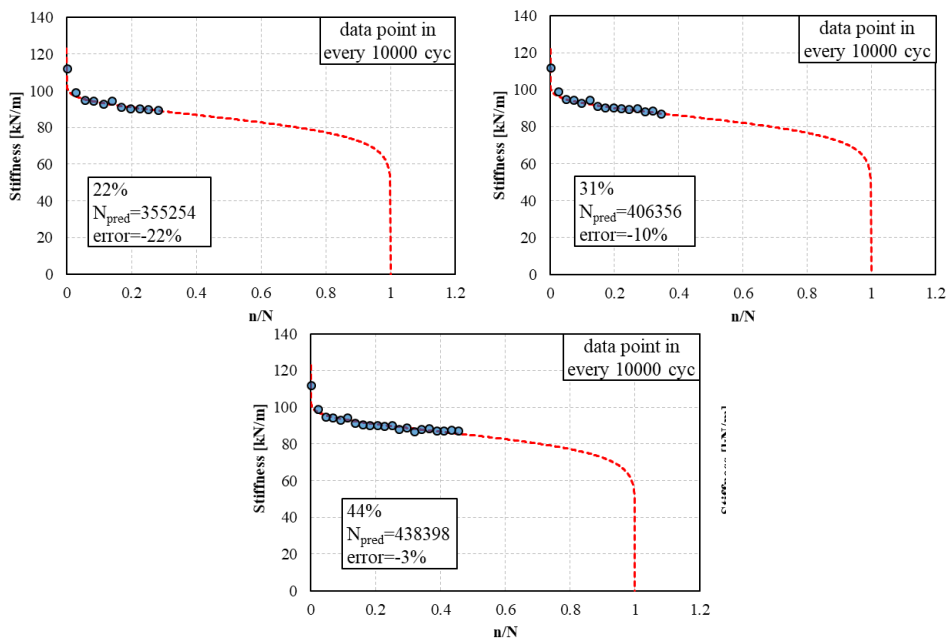


Figure 9. Final stiffness degradation predictions

In Fig. 8, the stiffness degradation curves correspond to the fatigue life prediction which gives the greatest coincidence with the linear portion of the experimental data. Each set of experimental data, i.e. each portion of the fatigue life, gave different result accuracy. The largest relative error, compared to the actual fatigue life of tested sample, was 22%. It was obtained using the data from 22% of actual fatigue life. The smallest error of the predicted fatigue life was 3%, and it was obtained using the data from the 44% of the fatigue life. It is worth noting that all fatigue life predictions were on the safe side. On the other hand, the relative error of the predictions of the S-N curve was about 50% (227094 cycles for the loading level of 4kN).

## 6. CONCLUSION

In this paper, the procedure for fatigue life prediction of adhesive joints by monitoring the load displacement behavior of samples subjected to cyclic loading was presented. Predictions were based on stiffness degradation model parameters obtained from the test results of only three samples whose load-displacement behavior was continuously monitored and recorded. In order to determine the influence of the duration of stiffness monitoring three different portions of the entire set of stiffness values of the sample tested until failure were used. It was observed that the accuracy of the predictions increased with the increase of the monitoring duration. A very high accuracy of fatigue life prediction was obtained. After monitoring only 22% of the fatigue life of tested sample, the predictions were significantly better than the predictions of widely used S-N curve method. A very important fact is that all the predictions were on the safe side, which is of great importance for the practical application. The other advantage of the developed method is that, besides testing a few samples until failure for obtaining model parameters, it uses the data obtained by non-destructive testing. This also implies that the predictions are obtained for the samples that are being tested, which is fundamental for monitoring based predictions.

## REFERENCES

- [1] V. Shenoy, I.A. Aschroft, G.W. Chritchlow, A.D. Crocombe: **Fracture mechanics and damage mechanics based fatigue lifetime prediction of adhesively bonded joints subjected to variable amplitude fatigue.** *Engineering Fracture Mechanics*, vol. 77, No. 7, 1073 – 1090, 2010.
- [2] Y.S. Upadhyaya; B.K. Sridhara: **Fatigue life prediction: A Continuum Damage Mechanics and Fracture Mechanics approach.** *Materials & Design*, vol. 35, 220-224, 2012.
- [3] J. R. Schaff, B. D. Davidson: **Life Prediction Methodology for Composite Structures. Part I—Constant Amplitude and Two-Stress Level Fatigue.** *Journal of Composite Materials*, vol. 31, No. 2, 128 – 157, 1997.
- [4] G.P. Sendekyj: **Life prediction for resin–matrix composite materials.** *Composite material series*, Vol. 4, 431–483, 1991.
- [5] M. Savvilidou, T. Keller, A. P. Vassilopoulos: **Fatigue performance of a cold-curing structural epoxy adhesive subjected to moist environments.** *International Journal of Fatigue*, Vol. 103, 405–414, 2017.
- [6] C. Blanchard, A. Chateauminois, L. Vincent: **A new testing methodology for the assessment of fatigue properties of structural adhesives.** *International Journal of Adhesion and Adhesives*, Vol. 16, No. 4, 289-299, 1996.
- [7] J. Petermann, K. Schulte: **The effects of creep and fatigue stress ratio on the long-term behaviour of angle-ply CFRP.** *Composite Structures*, Vol. 57, 205-210, 2002.
- [8] A. Benaarbia, A. Chrysochoos, G. Robert: **Thermomechanical behavior of PA6.6 composites subjected to low cycle fatigue.** *Composites Part B: Engineering*, vol. 76, 52–64, 2015.
- [9] P. R. Jaiswal, R. I. Kumar, W. de Waele: **Unified methodology for characterisation of global fatigue damage evolution in adhesively bonded joints.** *Frattura Ed Integrita Strutturale*, Vol. 14, No. 53, 26–37, 2020.

- [10] J.A. Ferreira, P. Reis, J.D. Costa, M.O. Richardson: **Fatigue behaviour of composite adhesive lap joints**. *Composites Science and Technology*, Vol. 62, 1373–1379, 2002.
- [11] Y. Zhang, A.P. Vassilopoulos, T. Keller: **Stiffness degradation and fatigue life prediction of adhesively-bonded joints for fiber-reinforced polymer composites**. *International Journal of Fatigue*, Vol. 30, 1813–1820, 2008.
- [12] S.O. Olajide, B.D. Arhatari: **Recent progress on damage mechanisms in polymeric adhesively bonded high-performance composite joints under fatigue**. *International Journal of Fatigue*, Vol. 95, 45–63, 2017.
- [13] **Methodenentwicklung zur Berechnung und Auslegung geklebter Stahlbauteile im Fahrzeugbau bei schwingender Beanspruchung**, Forschungsvorhaben P 653 / IGF-Nr. 141 ZN. Düsseldorf, 2012.
- [14] H.A. Whitworth: **A stiffness degradation model for composite laminates under fatigue loading**. *Composite Structures*, Vol. 40, 95–101, 1997.
- [15] N. Stojković: **Istraživanje ponašanja adhezionih spojeva metalnih konstrukcija pod dejstvom statičkog i cikličnog opterećenja**, *PhD Thesis, University of Niš, Niš*, 2017.
- [16] N. Stojković, D. Stojić, S. Živković, G.T. Čurčić: **Algorithm for determination of sn curves of the structural elements subjected to cyclic loading**, *Facta Universitatis, Series: Architecture and Civil Engineering*, Vol.16, No. 1, 081-091, 2018.

# TOWARDS NUMERICAL ARCHITECTURAL ORDER IDENTIFICATION: EXPRESSING CAPITAL MORPHOLOGY BY USING DYNAMICS OF ITS PARAMETERS

Djordje Mitrović<sup>1</sup>, Djordje Djordjević<sup>2</sup>, Mirjana Devetaković<sup>3</sup>,  
Gordana Djukanović<sup>4</sup>

## Abstract

*Previous subject-related research, that describes stylistic peculiarities of artefacts by taking into account their morphometric/geometric characteristics, explicates the results (used to differentiate them in terms of style they belong to) mainly descriptively – by evaluating the obtained data visually.*

*The narrower aim of this Paper is to explicate the mentioned characteristics numerically/quantitatively by transposing stylistic-wise parameters (descriptors of fractal and non-fractal nature), previously investigated by the actual authors, into the form of dynamics of their values namely explicators. Therefore, the main research questions of this study are both how to express artefact morphology by using dynamics of its parameters and, thus, how to numerically/quantitatively identify architectural style concrete artefact belongs to.*

*To achieve that scientifically, a triplet of capital samples (as the most distinctive elements among artefacts), namely their digital 3D models, are employed per each fundamental classical architectural order (Doric, Ionic, and Corinthian). The subject of this Paper is to establish relevant morphometric/geometric indicators not only in the form of explicators mentioned above, but qualifiers too, enabling so: to numerically express capital morphology, namely to quantitatively estimate levels of intra-similarity of capitals assumed to belong to the same order, and inter-dissimilarity of those assumed to belong to different ones. Both types of the established indicators refer to capital contours which are positioned in mutually equidistant transverse section planes (defined per each chosen capital sample of each of the analysed orders).*

*The wider research aim refers to both: (a) a possibility to numerically/quantitatively identify order a concrete fragment of capital/artefact belongs to in terms of recognising it computationally (as confidently as possible from the mathematical probability point of view), and (b) to perform morphology-wise capital/artefact segmentation.*

*Presented innovative methodology brings up a more reliable possibility to identify architectural order “stylistically unknown capital” belongs to – by using a newly introduced indicator (in the form of dynamics) to express its morphology numerically/quantitatively. Future research will be dealt with software-wise automation of stylistic decoding steps (rough capital classification and order-belonging estimation).*

**Key words:** *dynamics, fractal object, numerical stylistic analysis, morphology-wise parameters, classical architectural order capital*

---

<sup>1</sup> PhD Student, Teaching Assistant, University of Belgrade, Faculty of Architecture, djordje.mitrovic@arh.bg.ac.rs

<sup>2</sup> PhD, Associate Professor, University of Belgrade, Faculty of Architecture, djordje@arh.bg.ac.rs

<sup>3</sup> PhD, Assistant Professor, University of Belgrade, Faculty of Architecture, mirjana.devetakovic@arh.bg.ac.rs

<sup>4</sup> PhD, Associate Professor, University of Belgrade, Faculty of Forestry, gordana.djukanovic@sfb.bg.ac.rs

## 1. INTRODUCTION

To express artefact morphology in the scientifically sustainable way, various parameters of different nature have to be employed. More suitable ones are of fractal nature, expressed by the usage of fractal geometry, due to the fact that its principles can adequately explicate morphology in a whole. In the domains of architecture and urbanism, previous research is predominantly carried out in the fields of design, construction, heritage preservation, human-building interactions and others ([1], [2], [3], [4], [5], [6], [7]).

Additionally, mentioned fractal approach is capable of characterising artefacts geometric features mathematically regarding style they belong to [8]. But, especially in the case of classical architectural orders, a specific newly investigated methodology is developed to qualify and classify belonging capitals as well as to identify/recognise such orders stylistically (by taking into account their morphometric/geometric characteristics, explicating the results mainly descriptively – by evaluating the obtained data visually) [9].

Therefore, the narrower aim of this Paper is to explicate the mentioned characteristics numerically/quantitatively by transposing already introduced stylistic-wise parameters (descriptors) [9] into the form of dynamics of their values (named “explicators”). The main research questions of this study are both how to express capital morphology by using dynamics of its parameters and, thus, how to numerically/quantitatively identify architectural order concrete capital belongs to.

The subject of this Paper is to establish relevant morphometric/geometric indicators in the form of explicators and qualifiers, enabling so to numerically express capital morphology, namely to quantitatively estimate levels of intra-similarity of capitals assumed to belong to the same order, and inter-dissimilarity of those assumed to belong to different ones. Indicators refer to corresponding/ descriptors (inherited from the previous subject-related research conducted by the same authors [9]) obtained by processing capital contours which are positioned in mutually equidistant transverse section planes (related to each of the chosen capitals, namely their digital 3D models).

The wider research aim refers to both: (a) a possibility to numerically/quantitatively identify order a concrete fragment of capital belongs to in terms of recognising it computationally (as confidently as possible from the mathematical probability point of view), and (b) to perform morphology-wise capital segmentation (as a precondition of semantic one) – by employing artificial intelligence in terms of machine learning, primarily [10], [11].

## 2. METHODOLOGY

In order to reach the aims tasked, the main methodology principles are retrieved from the previous research [9], including the definition of indicators (descriptors and qualifiers) and relevant outputs obtained (descriptors values). However, so as the obtained results to be numerically/quantitatively explicable as much as possible, and thus morphometric changes described by trendlines easily detectable, the applied methodology is slightly “tuned”. Consequently, descriptor trendlines are substituted in this research with those of explicators, expressed by dynamics of values of corresponding descriptors. Bearing in mind the fact that the exact spatial positioning

(by using an adequate polar coordinate system) of morphology-wise excesses (morphometric marks of capitals of concrete order) is not considered here from the Paper topic point of view as well as the fact that capital contours from the set which refers to mutually equiangular radial section planes are not “informative” enough regarding the same reason, set of contours of transverse slicing is used here only (unlike it is a case in [9], where both of mentioned sets of contours are processed on an equal footing).

Indicators mentioned in Section 1. are expressed by both: several explicators of fractal and non-fractal nature (as an auxiliary one), and several corresponding qualifiers which are represented by arithmetically averaged values of analysed explicators – expressing so their global “from-section-to-section” changing rule. The nature of the established explicators and qualifiers are broadly explained in Sub-section 2.2.2.

## **2.1. Starting considerations**

To draw scientifically acceptable conclusions, prerequisites and constraints listed in [9] are to be satisfied as mandatory (Morphometry/Geometry-related and ImageAnalysis-related ones).

## **2.2. Methodology setup**

### **2.2.1. Samples selection**

To elaborate on a sustainability of the established capital qualification, capital classification, and numerical/quantitative order identification criteria as well as a validity of defined principles of the aim-related methodology, three representatives (hereinafter: “triplet”) per each fundamental classical architectural order are used (Doric, Ionic, and Corinthian). For a more detailed explanation of previously mentioned selection criteria, one can consult corresponding methodology setup principles described in [9].

### **2.2.2. Indicators definition**

According to the purpose of this research, two types of explicators are defined: the main one – represented by dynamics of descriptors of fractal nature (related to the distribution of (multi)fractal dimensions of capital contours located in each of its transverse section planes – expressed by a unitless value), and the auxiliary one – represented by dynamics of descriptors of non-fractal nature (related to the distribution of areas bounded by the previously generated corresponding sets of contours – expressed by square metres). The auxiliary type of explicators is foreseen due to the same reasons as those of corresponding control descriptors [9]. Consistent with the fundamental meaning of the term “dynamics” (describing it as a changing rate or variation level between two neighbouring values of the same nature (namely, of descriptors inherited from [9]) divided by the adopted unit step of that variation (hereinafter: “AUS”, namely, a distance between two consecutive section planes), following explicators are introduced: FractalExplicatorTransverse (hereinafter: “FET”), and AreaExplicatorTransverse (hereinafter: “AET”).

FET describes a changing rate of fractal-wise descriptor values (FDTs inherited from [9]) along the transverse slicing direction, namely, a variation level between each two consecutive such values divided by AUS of that variation. AET describes

a changing rate of non-fractal-wise descriptor values (ADTs also inherited from [9]) along the transverse slicing direction too, namely, a variation level between each two consecutive such values divided by AUS of that variation.

As in [9], two types of qualifiers are defined, as well: the first one which relates to arithmetically averaged values of explicators of fractal nature, and the second one which relates to arithmetically averaged values of explicators of non-fractal nature – both obtained separately for each triplet of contours defined by section planes of the same ordinal number, namely of the same slicing position in the corresponding triplet of capital samples of the same order (hereinafter: “1st”, “2nd”, and “3rd” sample).

Those types are named in this research as follows: FractalMeanTransverse (hereinafter: “FQT”), and AreaMeanTransverse (hereinafter: “AQT”). Having in mind the previously mentioned explicators typology as well as the fact that qualifiers are derived from, it is obvious that the firstly listed qualifier is also the main one, while the other one is the auxiliary.

### 2.2.3. Quantifiers definition

To achieve data-driven order identification/recognition (based on previously introduced indicators, namely explicators and qualifiers derived from), several quantifiers related to the desired number of AUSs (which approximately<sup>5</sup> correspond to capital canonical zones<sup>6</sup> they refer to) ought to be introduced. Ones, generally declared the most important, are following: (a) Number of Peaks<sup>7</sup>/Valleys<sup>8</sup>, Their Extreme Values, and Distances between Those Extremes Expressed by Number of AUSs, (b) Density of Peaks/Valleys and Their Extreme Values, (c) Intervals between Each Two Consecutive Peaks/Valleys and Their Extreme Values, and (d) Amplitudes of Each Neighbouring Peak-Valley Pair, Their Extreme Values, and Distances between Those Extremes Expressed by Number of AUSs.

A number of the aforementioned capital canonical zones (signed here in Roman numerals (I, II,...)) vary from order to order as it is shown in Figure 1.

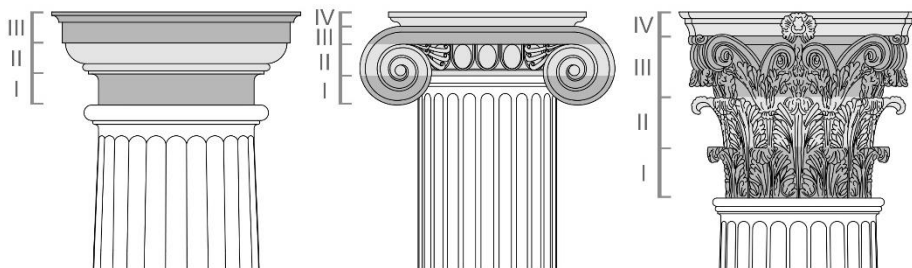


Figure 1. Marked Capital Canonical Zones of Doric, Ionic, and Corinthian Orders (from left to right) – Signed in Roman Numerals

<sup>5</sup> Proportion rules imply that the heights of capital canonical zones contain a number of AUSs which is not always an integer.

<sup>6</sup> Canonical zone of capital of concrete order is a segment of its mass whose height is defined with respect to the overall capital height according to corresponding proportion rules [12], [13].

<sup>7</sup> Peak is the value of indicator that refers to the case when behaviour of its change along the applied slicing direction is characterised by an increase-to-decrease transition.

<sup>8</sup> Valley is the value of indicator that refers to the case when behaviour of its change along the applied slicing direction is characterised by the decrease-to-increase transition.

Doric capitals generally consist of three visually recognisable morphology-wise zones, while Ionic and Corinthian ones consist of four such zones.

Bearing in mind the quantifiers listed above, due to the limited number of pages, Number of Peaks/Valleys are analysed only. Two classes of chosen quantifier are introduced: Number-of-Peak Quantifier (hereinafter: "NOP Qnt"), Number-of-Valley Quantifier (hereinafter: "NOV Qnt").

### 3. INDICATORS AND QUANTIFIERS OBTAINING

#### 3.1. Explicators calculating

According to the FET/AET definition (stated in Sub-subsection 2.2.2.), based on corresponding FDT/ADT descriptor values inherited from [9], with respect to equation (1)/(2), explicators calculation is performed by the usage of Excel.

$$Kth FET_{(i \rightarrow (i+1))} = (Kth FDT_{(i+1)} - Kth FDT_{(i)}) / AUS, i=(1, n-1), K=(1, 2, 3)$$

where "n" is the total number of transverse section planes,  
while "K" is the ordinal number of concrete capital sample (1)

$$Kth AET_{(i \rightarrow (i+1))} = (Kth ADT_{(i+1)} - Kth ADT_{(i)}) / AUS, i=(1, n-1), K=(1, 2, 3)$$

where "n" is the total number of transverse section planes,  
while "K" is the ordinal number of concrete capital sample (2)

#### 3.2. Qualifiers calculating

According to the FQT/AQT definition (stated in Sub-subsection 2.2.2.), based on each triplet of corresponding previously obtained FET/AET explicators, with respect to equation (3)/(4), qualifiers calculation is also performed by the usage of Excel.

$$FQT_{(i \rightarrow (i+1))} = (1st FET_{(i \rightarrow (i+1))} + 2nd FET_{(i \rightarrow (i+1))} + 3rd FET_{(i \rightarrow (i+1))}) / 3,$$

$i=(1, n-1)$ , where "n" is the total number of transverse section planes (3)

$$AQT_{(i \rightarrow (i+1))} = (1st AET_{(i \rightarrow (i+1))} + 2nd AET_{(i \rightarrow (i+1))} + 3rd AET_{(i \rightarrow (i+1))}) / 3,$$

$i=(1, n-1)$ , where "n" is the total number of transverse section planes (4)

#### 3.3. Quantifiers calculating

According to the NOP Qnt/NOV Qnt definition (stated in Sub-subsection 2.2.3.), based on each triplet of corresponding previously obtained FET/AET explicators namely on each FQT/AQT qualifiers derived from, with respect to equation (5)/(6) namely (7)/(8), quantifiers calculation is performed by the usage of Excel – per each capital canonical zone, separately.

$$Kth NOP Qnt (FET) = Kth NOP Qnt (FET)_I + Kth NOP Qnt (FET)_{II} + \dots,$$

$$Kth NOP Qnt (AET) = Kth NOP Qnt (AET)_I + Kth NOP Qnt (AET)_{II} + \dots,$$

$K=(1, 2, 3)$ , where "K" is the ordinal number of concrete capital sample,  
while "I, II,..." are ordinal numbers of canonical zones of Kth capital sample (5)

$$Kth NOV Qnt (FET) = Kth NOV Qnt (FET)_I + Kth NOV Qnt (FET)_{II} + \dots,$$



$$Kth\ NOV\ Qnt\ (AET) = Kth\ NOV\ Qnt\ (AET)\_I + Kth\ NOV\ Qnt\ (AET)\_{II} + \dots, \\ K=(1, 2, 3), \text{ where "K" is the ordinal number of concrete capital sample,} \\ \text{while "I, II,..."} \text{ are ordinal numbers of canonical zones of Kth capital sample} \quad (6)$$

$$NOP\ Qnt\ (FQT) = NOP\ Qnt\ (FQT)\_I + NOP\ Qnt\ (FQT)\_{II} + \dots, \\ NOP\ Qnt\ (AQT) = NOP\ Qnt\ (AQT)\_I + NOP\ Qnt\ (AQT)\_{II} + \dots, \\ \text{while "I, II,..."} \text{ are ordinal numbers of canonical zones of concrete order} \quad (7)$$

$$NOV\ Qnt\ (FQT) = NOV\ Qnt\ (FQT)\_I + NOV\ Qnt\ (FQT)\_{II} + \dots, \\ NOV\ Qnt\ (AQT) = NOV\ Qnt\ (AQT)\_I + NOV\ Qnt\ (AQT)\_{II} + \dots, \\ \text{while "I, II,..."} \text{ are ordinal numbers of canonical zones of concrete order} \quad (8)$$

### 4. RESULTS

The results are differently represented with respect to the fact whether they refer to the obtained values of indicators or quantifiers. So, first ones are in the form of six charts (3x2=6). Charts 1, 3, and 5. show transverse-wise trendlines triplets of explicators of both defined types (fractal and non-fractal), related to the triplet of capital samples of the same order. Charts 2, 4, and 6. show transverse-wise trendlines of qualifiers of the same previously mentioned types. Each qualifier trendline (as mean one) substitutes the corresponding triplet of explicator trendlines by "averaging" it (hereinafter: "Dor FQT", "Ion FQT", "Cor FQT" and "Dor AQT", "Ion AQT", "Cor AQT").

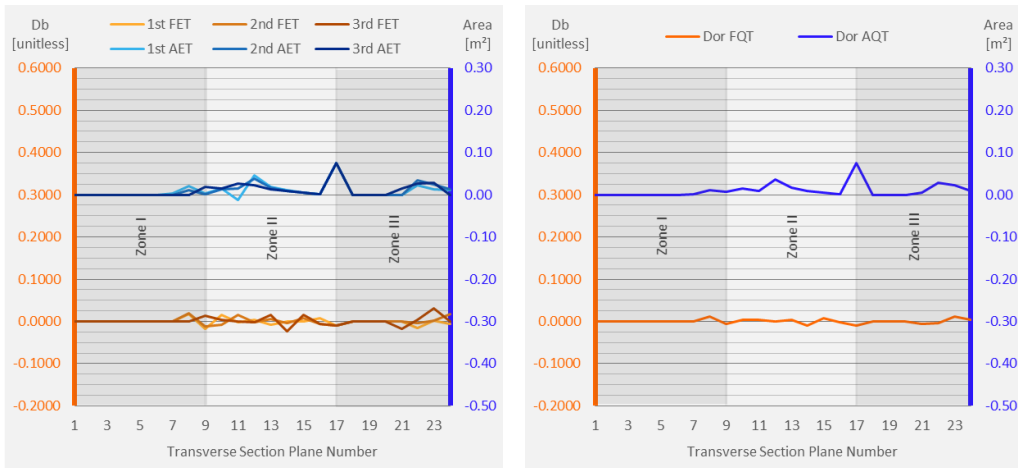


Chart 1. (left) Intra-order "Doric" Similarity: Transverse-wise Explicator Trendlines Related to the Triplet of Corresponding Capital Samples

Chart 2. (right) Transverse-wise Fractal and Non-fractal Qualifier Trendlines That Substitute Triplets of Corresponding Doric Explicator Trendlines

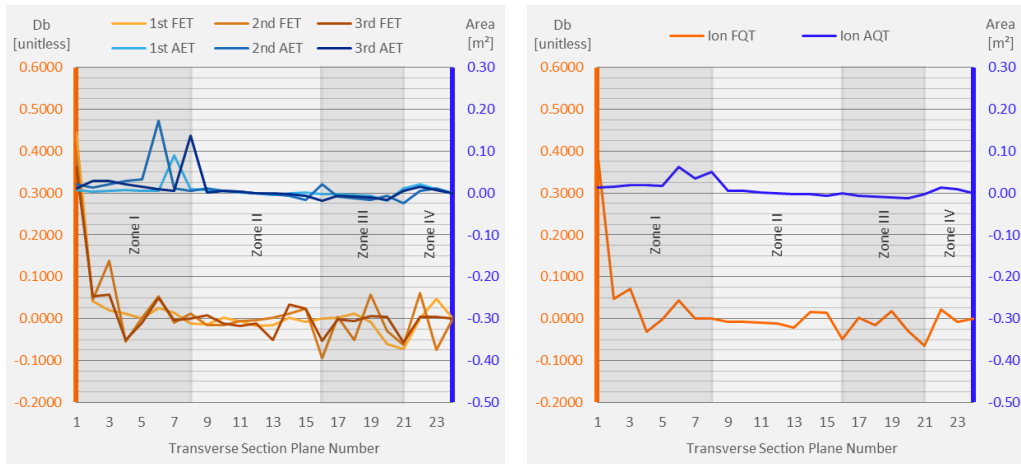


Chart 3. (left) Intra-order “Ionic” Similarity: Transverse-wise Explicator Trendlines Related to the Triplet of Corresponding Capital Samples

Chart 4. (right) Transverse-wise Fractal and Non-fractal Qualifier Trendlines That Substitute Triplets of Corresponding Ionic Explicator Trendlines

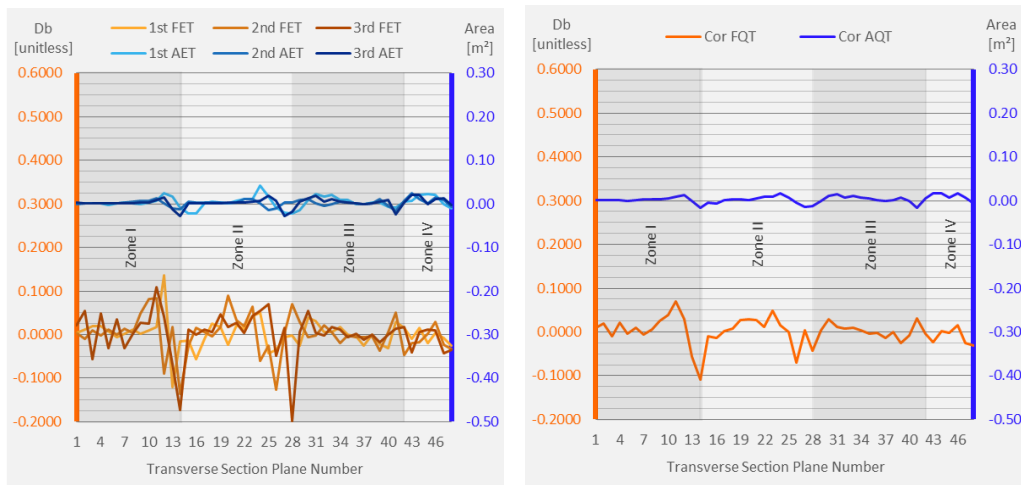


Chart 5. (left) Intra-order “Corinthian” Similarity: Transverse-wise Explicator Trendlines Related to the Triplet of Corresponding Capital Samples

Chart 6. (right) Transverse-wise Fractal and Non-fractal Qualifier Trendlines That Substitute Triplets of Corresponding Corinthian Explicator Trendlines

The quantifiers-related results are represented in the form of three tables (2+1=3) and variety of doughnut-charts derived from the corresponding filled-in results. Table 1. and Table 2. contain values of indicator-wise quantifiers regarding analysed orders and canonical zones of corresponding capital samples. Table 3. represents values of qualifiers numerical thresholds of fractal and non-fractal nature that relate to one of the examined orders only – the Corinthian one (due to its morphology-wise complexity – the greatest among analysed). Those thresholds are represented by minimal and maximal values of explicator-wise quantifiers and threshold means (qualifier-wise quantifiers) calculated by averaging.

Table 1. Intra-order Similarity: Values of Explicator-wise Quantifiers Regarding Analysed Orders and Canonical Zones of Corresponding Capital Samples

Table 1.			Canonical Zones of Selected Capital Samples												
			1st				2nd				3rd				
			I	II	III	IV	I	II	III	IV	I	II	III	IV	
Analysed Explicator-wise Quantifiers: Number of Peaks / Valleys	NOP Qnt	FET	Dor	1	3	2	/	1	3	1	/	1	2	2	/
			Ion	1	2	1	1	3	1	2	1	2	3	2	1
			Cor	4	4	4	2	5	5	4	1	5	6	5	1
		AET	Dor	1	3	1	/	1	2	1	/	1	2	1	/
			Ion	2	1	0	1	1	2	1	1	2	1	1	1
			Cor	2	2	3	1	1	3	3	2	1	1	3	2
	NOV Qnt	FET	Dor	1	3	1	/	1	3	1	/	0	3	1	/
			Ion	1	3	1	0	3	2	2	1	3	3	2	0
			Cor	3	4	4	2	6	4	5	0	5	6	4	2
		AET	Dor	1	2	1	/	1	1	1	/	0	2	1	/
			Ion	2	1	1	0	2	1	2	0	1	2	1	0
			Cor	2	3	3	0	1	3	3	1	2	1	3	1

Table 2. (left) Inter-order Dissimilarity: Values of Qualifier-wise Quantifiers Regarding Analysed Orders and Corresponding Capital Canonical Zones

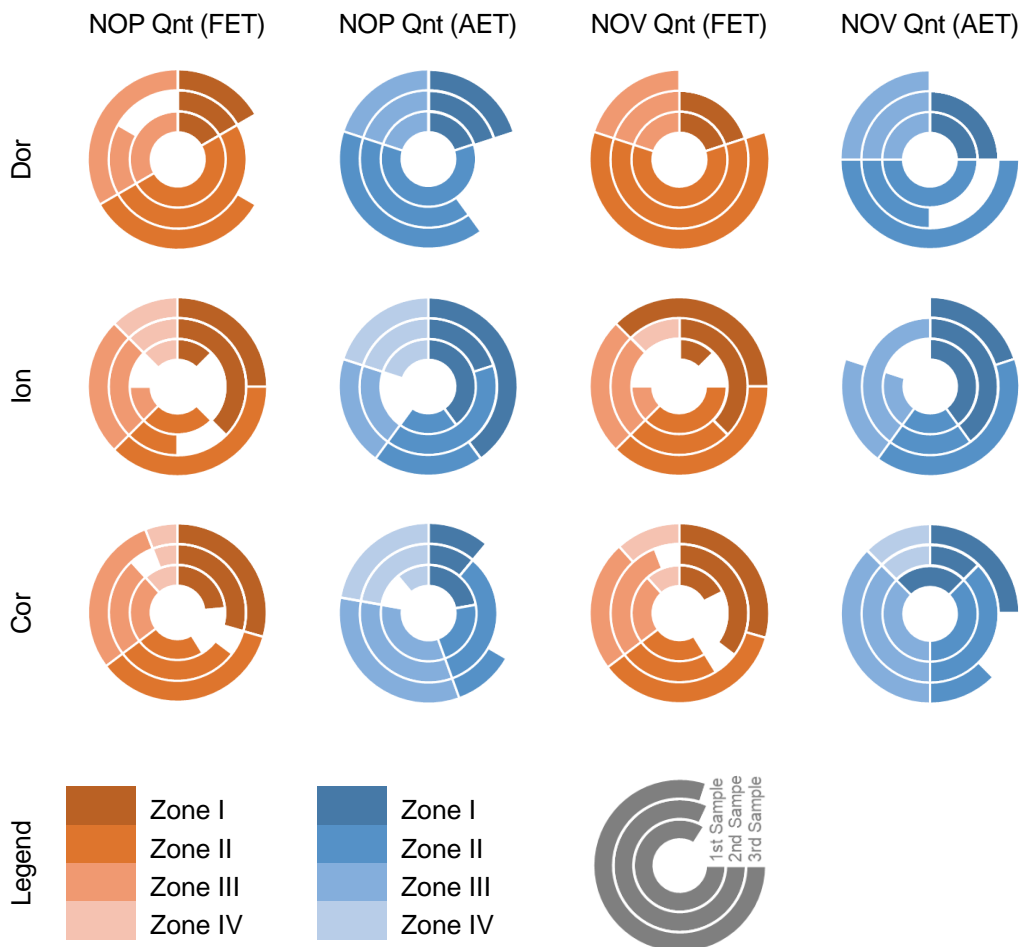
Table 3. (right) Corinthian Order Identification/Recognition: Values of its Qualifier-wise Quantifiers and Corresponding Thresholds (Min, Max) Related to Each Canonical Zone

Table 2.				Canonical Zones of All Analysed Orders			
				I	II	III	IV
Analysed Qualifier-wise Quantifiers: Number of Peaks / Valleys	NOP Qnt	FQT	Dor	1	3	2	/
			Ion	3	1	2	1
			Cor	4	4	5	2
		AQT	Dor	1	3	1	/
			Ion	3	1	0	1
			Cor	2	3	3	2
	NOV Qnt	FQT	Dor	1	3	1	/
			Ion	3	2	2	1
			Cor	4	4	4	2
		AQT	Dor	1	2	1	/
			Ion	2	1	1	0
			Cor	2	3	3	1

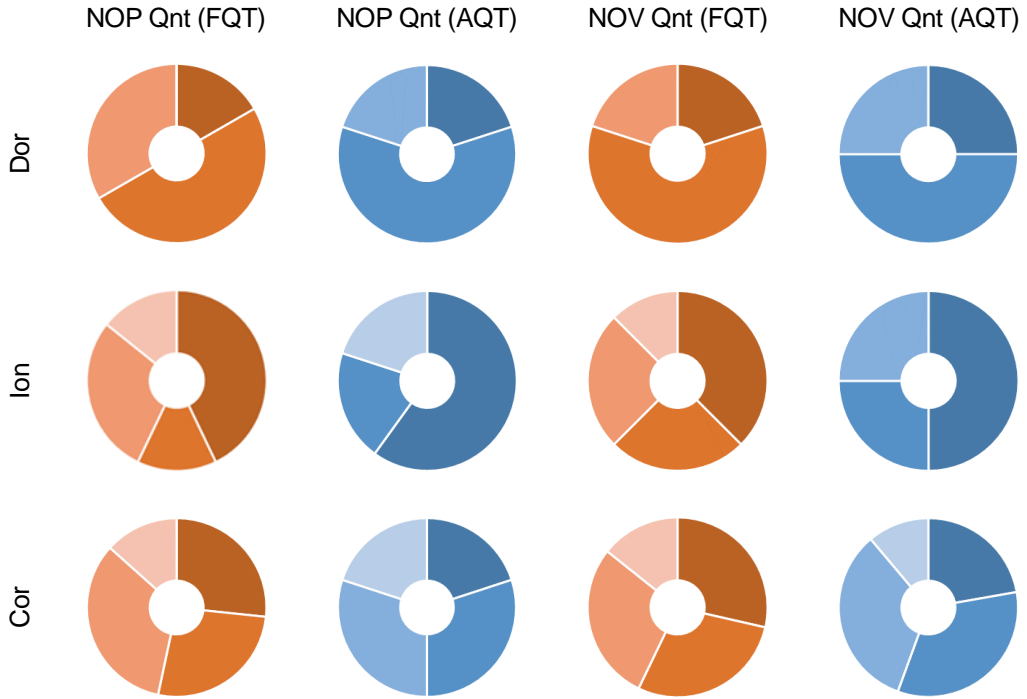
Table 3.			Canonical Zones of Corinthian Order				
			I	II	III	IV	
NOP Qnt	FET	Min	4	4	4	1	
		Cor	4	4	5	2	
		Max	5	6	5	2	
	FET	Min	1	1	3	1	
		Cor	2	3	3	2	
		Max	2	3	3	2	
	NOV Qnt	FET	Min	3	4	4	0
			Cor	4	4	4	2
			Max	6	6	5	2
		FET	Min	1	1	3	0
			Cor	2	3	3	1
			Max	2	3	3	1

Because of the facts that both capital heights differ from order to order and quantifiers values (which relate to the concrete canonical zone) might vary from sample to sample, to cross-reference the obtained results as reliably as possible, their relative values (calculated based on “absolute counting”) are only compared. Consistent with the fundamental meaning of the term “relative”, a percentage abundance of the analysed quantifiers values related to the concrete canonical zone is to be understood here with respect to their overall number that refers to the capital in whole. Given that the behaviour of trendlines shown in Charts 1, 3, and 5, namely, in Charts 2, 4, and 6 is described by explicators which are functionally dependent on descriptors inherited from [9] (as obtained from them arithmetically), namely, by qualifiers derived from corresponding explicators (by averaging them), the charts mentioned above (that demonstrate an intra-order similarity, namely, an inter-order dissimilarity as identically as those already elaborated in [9]) will not be discussed here, but only behaviours of the researched quantifiers read out from created doughnut-charts (Doughnut-charts 1, 2, and 3).

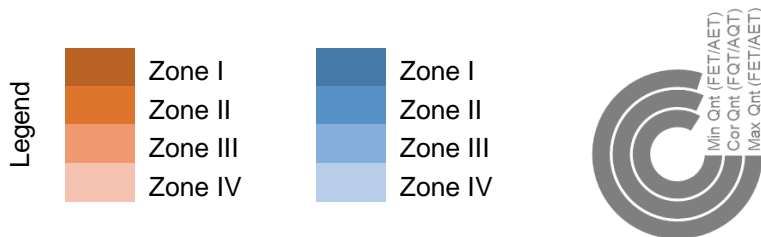
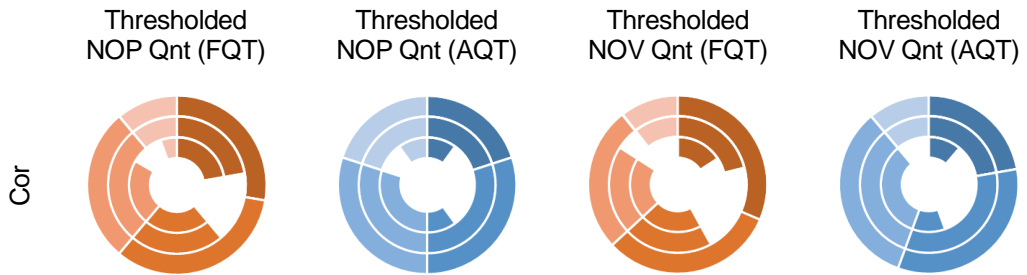
*Doughnut-charts 1. Percentage Abundance of Fractal and Non-fractal Explicator-wise Quantifiers for Doric, Ionic, and Corinthian Order with Regard to Analysed Triplets of Capital Samples and Their Corresponding Canonical Zones*



*Doughnut-charts 2. Percentage Abundance of Fractal and Non-fractal Qualifier-wise Quantifiers Regarding Analysed Doric, Ionic, and Corinthian Order and Corresponding Capital Canonical Zones*



*Doughnut-charts 3. Corinthian Order Identification/Recognition: Percentage Abundance of its Fractal and Non-fractal Qualifier-wise Quantifiers Thresholded by Corresponding Min and Max Percentage Abundances of Explicator-wise Quantifiers Regarding Capital Canonical Zones*



## 5. DISCUSSION AND CONCLUSION

Doughnut-charts 1. Mutually similar behavior of the explicator-wise quantifiers of both types (fractal: orange coloured and non-fractal: blue coloured), and of both classes (NOP and NOV) among the analysed capital samples from the same triplet can be declared almost identical when doughnut rings occupancy namely proximity of sizes<sup>9</sup> of their slices which relate to the same zone are pretty balanced<sup>10</sup>, confirming so intra-order similarity. Slight deviations of doughnut rings occupancy that relate to some of the samples, regardless of orders they belong to (represented by certain blank parts of corresponding rings), could be caused by the following issues: either because of the used 3D models inadequacy (when ones do not conform with the originals from morphology-wise point of view) or because of morphometric non-compliance with strict canonicity.

Doughnut-charts 2. The more similar behaviour of the qualifier-wise quantifiers of the same order and class is (regardless of their type), the greater proximity of sizes of doughnut slices<sup>11</sup> will be, providing so more detectable inter-order dissimilarity. Even though doughnuts of the same class and type related to different orders might seem mutually almost identical (for example: Ion NOV Qnt (FQT) and Cor NOV Qnt (FQT)), corresponding doughnuts of the remaining analysed class and/or type do answer whether those quantifiers could be declared members of the same or mutually different orders. It is obvious that the larger number of analysed capitals (representative samples) is, the more accurate sizes of doughnut slices and thus their intra-doughnut distribution (as well as the more reliably inter-order dissimilarity estimation) will be. In that case, as well, it is possible to estimate whether that distribution can be declared acceptable from the statistical probability point of view, by using previously defined relevant thresholds (tolerance).

Doughnut-charts 3. For the reason explained in Section 4., Doughnut-charts 3. are created only – based on data shown in Table 3. By observing containing doughnuts, it is obvious that corresponding “Corinthian” qualifier-wise quantifiers (whose canonical zone-related values are represented by sizes of the middle-ring-slices) belong to the corresponding (zone-related) tolerance ranges (defined by related Min (sizes of the inner-ring-slices) and Max thresholds (sizes of the outer-ring-slices)). Based on the usage of that stylistically known capital, satisfied mentioned condition (being conformed to the acceptable tolerance range) confirms scientific sustainability of the established approach.

It can be concluded that the presented innovative methodology (developed from [9] and slightly “tuned”) brings a more reliable possibility to identify architectural order “stylistically unknown capital” belongs to – by using a newly introduced indicator (in the form of dynamics) to express its morphology numerically/quantitatively. Future research will be dealt with software-wise automation of stylistic decoding steps (rough capital classification and order-belonging estimation).

<sup>9</sup> Size of the ring slice (which refers to the concrete canonical zone of the particular capital sample from the analysed triplet of samples) is a term related to the value of corresponding explicator-wise quantifier. (NOP Qnt (FET/AET)/NOV Qnt (FET/AET))

<sup>10</sup> Balanced occupancy of doughnut rings refers to the approximate “equality” of sizes of belonging slices related to the same capital canonical zone of the concrete order. Term “equality” implies the usage of previously calculated probabilistically acceptable thresholds (tolerance).

<sup>11</sup> Size of the doughnut slice (which refers to the particular canonical zone of triplet of capital samples of the concrete order – represented by that slice) is a term related to the value of corresponding qualifier-wise quantifier (NOP Qnt (FQT/AQT)/NOV Qnt (FQT/AQT))

## ACKNOWLEDGMENTS

This investigation is performed at the University of Belgrade – Faculty of Architecture, within the “Laboratory for Research, Valorisation, Conservation and Presentation of Cultural Heritage”, founded and financed by the Ministry of Science, Technological Development and Innovation of the Republic of Serbia, grant number 451-03-47/2023-01/200090.

## REFERENCES

- [1] Yamu Claudia van der Laag, Frankhauser Pierre: **A multi-scale (multi-fractal) approach for a systemic planning strategy from a regional to an architectural scale**. *15th International Conference on Urban Planning, Regional Development and Information Society 2010*, Vienna, 17-26, 2010.
- [2] Athanasiou Apostolos, Ebrahimkhanlou Arvin, Zaborac Jarrod, Hrynyk Trevor, Salamone Salvatore: **A machine learning approach based on multifractal features for crack assessment of reinforced concrete shells**. *Computer-Aided Civil and Infrastructure Engineering*, Vol. 35, No. 6, 565–578, 2020.
- [3] Carpinteri Andrea, Spagnoli Andrea, Vantadori Sabrina: **A multifractal analysis of fatigue crack growth and its application to concrete**. *Engineering Fracture Mechanics*, Vol. 77, No. 6, 974–984, 2010.
- [4] Ji Hui, Yang Xiong, Ling Haibin, Xu Yong: **Wavelet domain multifractal analysis for static and dynamic texture classification**. *IEEE Transactions on Image Processing*, Vol. 22, No. 1, 286–299, 2013.
- [5] Devetaković Mirjana, Petruševski Ivana, Ćirović Ivana, Petruševski Ljiljana: **Fractal parametric models of urban spaces**. *Tehnicki Vjesnik*. Vol. 22, No. 6, 1547-1552, 2015.
- [6] Ćirović Ivana: Random curds as mathematical models of fractal rhythm in architecture. *Spatium*. Vol. 1, No. 31, 79-84, 2014.
- [7] Đorđević Đorđe, Ćirović Ivana: **Visual complexity of fractal rhythm**. 11th International Scientific Conference “Science and Higher Education in Function of Sustainable Development”. Mećavnik-Drvengrad, Užice, 23-29, 2019.
- [8] Capo Daniele: **The fractal nature of the architectural orders**. *Nexus Network Journal*, Vol. 6, No. 1, 30–40, 2004.
- [9] Mitrović Djordje, Djordjević Djordje, Devetaković Mirjana, Djukanović Gordana: **Encoding/decoding capitals of classical architectural orders by using fractal geometry: Establishing methodology**. *9th International Scientific Conference on Geometry and Graphics, MoNGeometrija 2023*, Novi Sad, 153-167, 2023.
- [10] Diara Filippo, Rinaudo Fulvio: IFC Classification for FOSS HBIM: Open issues and a schema proposal for cultural heritage assets. *Applied Sciences*, Vol. 10, No. 23, 8320, 2020.
- [11] Quattrini Ramona, Carlo Battini, Mammoli Raissa: **HBIM to VR. semantic awareness and data enrichment interoperability for parametric libraries of historical architecture**, *Int. Arch. Photogramm. Remote Sens. Spatial Inf. Sci.*, XLII-2, 937–943, 2018.
- [12] Vitruvius Pollio Marcus: **Deset knjiga o arhitekturi = De architectura libri decem** (M.Lopac, Trans.; R.Jadrešin Milić, Ed.). *Orion art*, Beograd, 2014.
- [13] Chitham Robert: **The Classical Orders of Architecture** (2nd ed.). *Routledge*, London, 2005.

## SOME SIGNIFICANT ACHIEVEMENTS OF CONCRETE STRUCTURES

Nadja Kurtović Folić<sup>1</sup>, Radomir Folić<sup>2</sup>, Miloš Čokić<sup>3</sup>

### Abstract

*Since the beginning of the 20th century, modern concrete and its different variations have been the most frequently used material in structural engineering. Although it is a relatively young material (1855), thanks to its ability to take various forms, it has become widely accepted in all fields of civil engineering, and architecture (including sculptural architecture). Its widespread application and monolithic properties had considerably influenced the development of the theory of structures – spatial and curved (free form) surface carriers in particular. This created a theoretical basis for the analysis of the structures made of reinforced concrete, and pre-stressed and post-stressed concrete (hereinafter 'concrete'). Concrete has been the material of choice in creation of structures of various purposes and different aesthetic values.*

*This paper includes a brief overview of the achievement of well-known authors and researchers who have significantly influenced affirmation and wider application of concrete. Examples of some significant buildings, with a variety of functions, and their particular aesthetic properties are included in this paper. The consideration in this paper highlights the importance of conducting the research in the field of structural engineering aimed to improve methods of design, construction and maintenances of the structures. Current issues and directions of future research in the field of concrete structures and structures where concrete was combined with other materials were also pointed out.*

**Key words** reinforced concrete, prestressed concrete, design, structural art, aesthetic of structures, bridges, shells

---

<sup>1</sup> Dr, Prof. retired, . University of N. Sad, Novi Sad, Serbia; nfolic@gmail.com

<sup>2</sup> Dr, Prof. emeritus, University of Novi Sad, Novi Sad, Serbia, folic@uns.ac.rs; and r.folic@gmail.com

<sup>3</sup> Dr. Struct. designer, Termoenergo inženjering, Bulevar Kralja Aleksandra 298, Belgrade, Serbia; cokicmilos@gmail.com



## 1. INTRODUCTION

Until the 20<sup>th</sup> century, iron and steel prevailed in the construction of engineering structures (ES), but reinforced concrete, owing to the competition between cement factories and the steel industry, already took precedence during the last decades of the 19<sup>th</sup> century, and especially at the beginning of the 20<sup>th</sup> century. This was achieved thanks to the inventiveness and research of many creators who accepted concrete as a material for shaping aesthetically valuable structures [1]. Many of well known creators, with their talent and building philosophy, combined the structural skills and architectural sensibility. Some of their works, as well as some other famous authors, are presented here.

In addition to the different dates mentioned in the literature, it is believed that the application of reinforced concrete began in 1850 when the Frenchman Lambot reinforced the boat prepared for the World Exhibition in Paris in 1855. The introduction of prestressing began in the 20s of the 20<sup>th</sup> century with the work of Freysinnet [1].

Many well-known structures in the World that represented the idea of structural art were designed before advanced structural theory and modern tools were fully developed. Structural design is concerned with much more than science and techniques: it is very much concerned with art, common sense, sentiment, aptitude and enjoyment of the task of creating opportune outlines to which scientific calculations will add finishing touches, substantiating that the structure is sound and strong in accordance with the requirements [2].

The history of the relationship between architects and structural engineers went through a series of phases from the mid-19<sup>th</sup> century, when reinforced concrete began to be technologically advanced. This relationship had its ups and downs, but it became especially important when large covered spaces were formed. Both architects and structural engineers tend to make the reinforced concrete structures more attractive, but their design is therefore becoming more and more complex. This complexity directly reflects on the relation between the architect and the engineer, on the mutual understanding of the idea and the possibility of materializing it. This paper will deal in more detail with this problem by review of several important examples, based on which a conclusion can be drawn on the state of this relationship in the 21<sup>st</sup> century and points out the need to harmonize the relationship between the architect and the structural engineer [3].

## 2. DESIGN AND AESTHETICS OF STRUCTURES

Many buildings with remarkable structures are visually dominant in the urban landscape, so their aesthetics has an exceptional social significance. Their aesthetics permanently affects the mood of the people who use them or just observe them. That is why it is considered that technical progress in the theory and analysis of structures is not complete without the participation of the aesthetic values of the structures [F Priest]. Concrete is extensively used for the structures of various buildings, including sculptural architecture with artistic design. Engineers - designers of **structures**, rarely explicitly consider the aesthetic component when designing. The idea of structural art, creation of aesthetic values, is associated with D. Billington. However, the famous British engineer T. Telford defined design skills as early as

1812 as an individual expression of the structure in the light of satisfying efficiency (reliable performance with a minimum of material and labor costs) and economy (restriction of building and maintenance costs). The unity of the form of the structure and materials is important. Concrete makes it possible to achieve most diverse shapes, so it is often called a sculptural material [1].

Architects, sculptors and engineers work on the form shaping. The engineer-designer provides a scientific criterion, the architect a social one, and a sculptor a symbolic one. The designer must satisfy safety, serviceability and economy, but also achieve an adequate structural form. In the case of engineering structures and bridges, that form generally results from a structural idea, so the architect does not significantly influence its solution. Only the integration of form and structural requirements results in the structural skills [26].

The design of a structure begins with the choice of the structural form, with the layout of the supporting elements and the assessment of their dimensions. F. Candela [4], P. L. Nervi [28], E. Torroja [29] and the contemporary creator S. Calatrava especially contributed to those values. All of them, with their talent, combined the structural skills and architectural sensibility. The possibility of applying various forms of concrete structures has contributed to the development of the Theory of structures (structural supports) and the Technology of the execution of works, especially in the case of bridges.

### 3. REVIEW OF SOME AESTHETICALLY VALUABLE STRUCTURES

One of the first exceptional aesthetic accomplishment was achieved by R. Maillart (1872-1940) with the Salginatobel bridge over the ravine in Switzerland, in 1930. It is an example of an extraordinary fitting of a structure into the natural environment (Fig. 1). The hollow box arch enabled the record span of that time, 90 m, and the height/span ratio is 1/7.

Bridges placed in a natural or built environment attract the attention and looks of passers-by from different angles. They should have a clear composition and conception, sturdy and without unnecessary decorations [1]. In addition to knowledge of the theory of structures, materials and geotechnics, skill is necessary - the ability to compose in order to achieve harmony and agreement (balance of the span, height and transverse dimensions). The sequencing of openings and columns (rhythm) is also important. The building should maintain its function and possess clear uninterrupted structural lines and transmission of forces. In some cases, the bridge also has a semiotic component.

*Aesthetics* depends on the concept expressed through the general disposition, which reflects "elegant simplicity, structural definition, clarity and sincerity of expression of appearance and treatment of visible parts. It depends



Figure 1. [Salginatobel Bridge](#), Switzerland (Maillart) 1929/30, after [1]

on the play of light and shadow, on the landscape in which the bridge is situated, on the originality and modernity of the solution, on the surfaces and the line seen by the eye, on the impression of calm stability".

Public buildings have special features and occupy dominant positions in the built environment, so the aesthetic design is extremely important. They represent very attractive and recognizable objects [Sanches-Arcas, cit. in 1]. We recognize the cities by some attractive concrete buildings built in them. In evaluation and research of the form and structure, the initial points differ, depending on whether they are formed after the natural forms, or after those from the built up environment.

The first examples of dwelling shelter construction could only be observed by forms in nature and which the first men considered suitable to replicate to build forms that are required for certain purposes. The various construction developed by imitating the natural forms of bridging, sheltering, covering, space limiting.

This way of creating architecture could be traced through whole history until today. Since the laws of nature usually make the starting point for the fundamental laws of aesthetics, then, by their imitation, architectural aesthetics is largely related to their appearance in natural environment [6], [7] and [8].

Structures imitating the forms from natural world were built in many big cities, such as the Guggenheim Museum in New York, with an unusual shape of spiral structure. At the Guggenheim Museum, it is thought that Frank Lloyd Wright was inspired by nautilus shell for the spiral ramp and that the radial symmetry of a spider web initiated the design of the central space skylight (Fig. 2).



Figure 2. Inspirations for Guggenheim Museum, New York, F. L. Wright, 1959 [3]

**The TWA Flight Center**, designed by renowned architect Eero Saarinen and Associates, is an iconic airport terminal and hotel complex located at [JFK airport in New York City](#). Built between 1959 and 1962, the original terminal building features a distinctive shape of a bird with spread wings with a wing-shaped roof supported by "Y"-shaped piers and boasts an open interior with tall windows and two tube-

shaped departure-arrival corridors. Despite its demolition in parts, the head house remained and was adapted into the TWA Hotel in 2019. The encircling Terminal 5 addition, designed by Gensler, was constructed between 2005 and 2008 and houses the 26 active gates at Terminal 5, as well as various dining and shopping options. Recognized as both a New York City and National Landmark, the TWA Flight Center remains a timeless masterpiece (Fig. 3).



Figure 3 The TWA Flight Center, New York, E. Saarinen and Associates, 1962.

The Sydney Opera House is a modern expressionist design, with a series of large precast concrete "shells", each composed of sections of a sphere, forming the roofs of the structure, set on a monumental podium. Although the 'shells' of the Opera House resemble sails of a ship, the building's design was actually *inspired by nature*. Architect Jørn Utzon says he was more influenced by birds, clouds, walnuts and trees. Devising the roof sails proved to be one of the most difficult aspects of the process. The Opera House was also the focus for many architectural innovations. These included the pioneering use of computers to calculate the stresses and loads on the two-way curved roofs, and development of a way to build the roofs in concrete (Fig. 4).

At the same time in Europe was opened the Bürgi Garden Center. This thin shell that floats over a part of the garden in Camorino, Switzerland is a project of civil engineer Heinz Isler from 1973. His work, which imitates the sky, is the best evidence that thin shells were more popular than ever in the mid-XX century (Fig. 5).

An example of an in-depth approach to the nature of human body is the study drawing for the Torso building project in Malmö-Sweden and the building itself, by S. Calatrava. The building with 54 floors, 190 m high, was built in 2005. Its design was inspired by a marble sculpture of a twisting human torso made by Santiago Calatrava himself. Multi-educated as an architect, civil engineer and artist, it is no surprise that he describes his approach to architecture as more of an art than a science (Fig. 6). Thin shells were additionally seen as a sound design choice because when shaped correctly, they experienced little to no bending moment, and any compression that was found within the shell was uniformly distributed [12].

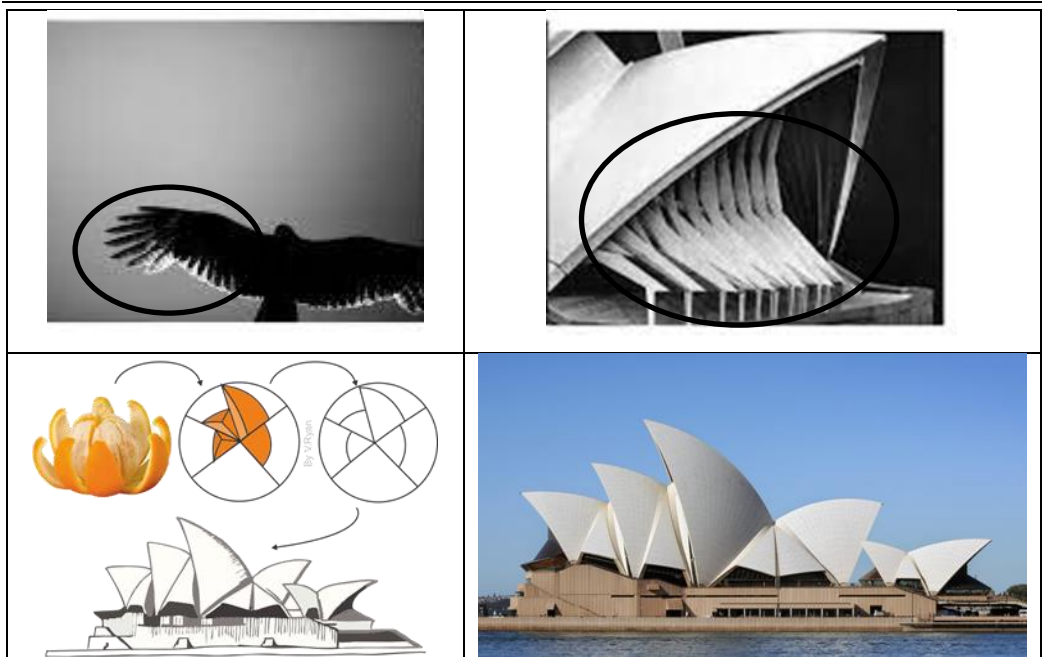


Figure 4. Inspirations for developing the form of Sydney Opera House, J. Utzon, 1973.

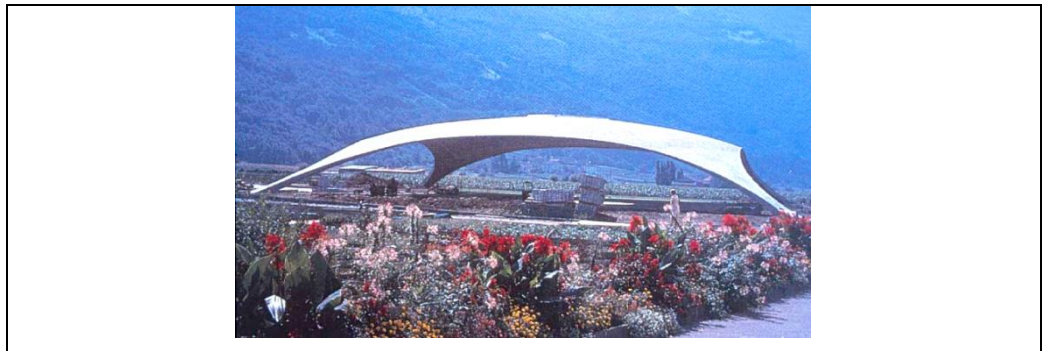


Figure 5. Heinz Isler, Bürgi Garden Center, Camorino, Switzerland, 1973, [3].

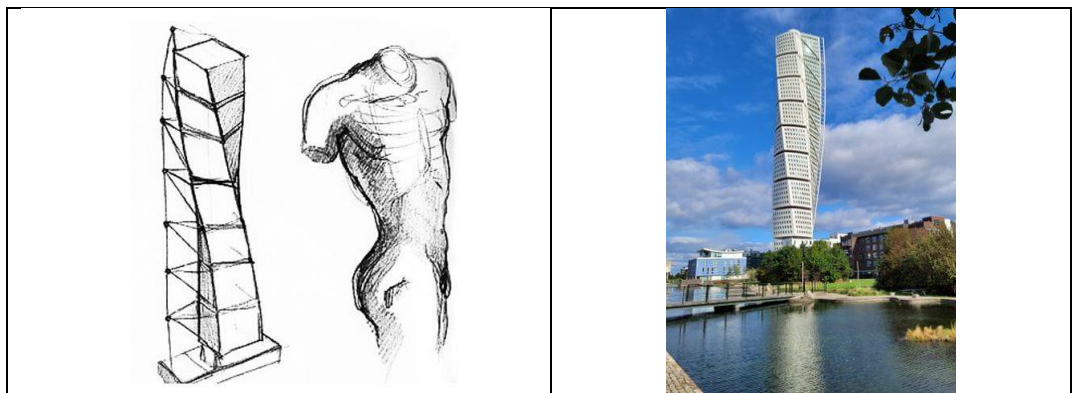


Figure 6. Torso building in Malmö, Sweden S. Calatrava, 2005.

Known both as architect and an engineer Pier Luigi Nervi (1891 – 1979) explored the limitation of reinforced concrete by creating a variety of imaginative and inventive structural projects. He started his incredible career, especially in the field of sports

facilities, even before the Second World War. The Artemio stadium in Firenze, with a giant canopy over the auditorium and a number of other attractive details was built in 1931 (Fig. 7).

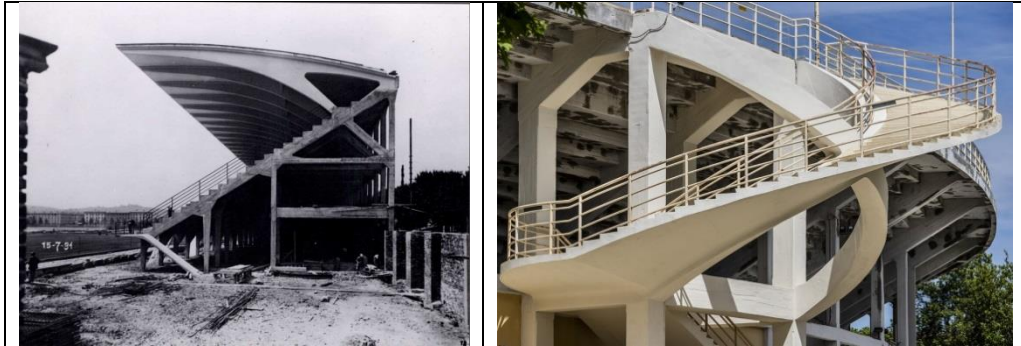


Figure 7. Stadio Artemio, Firenze, Italy, P.L. Nervi, 1931.

A special category of architectural buildings after WW II is curved structural supports (shells). They are classified in terms of the Gaussian curve, expressed through the ratio  $1/\rho_1\rho_2$ ; where  $\rho_1$  and  $\rho_2$  – are curve radii. If the Gaussian curve is zero, those are cylindrical shells with low strength without peripheral elements and diaphragms at its extremes. If the Gaussian curve is negative, those are saddle and hyperbolic paraboloid shaped curves, with tensions dominant in them. The positive curve characterizes domes and elliptical paraboloids. The support shape affects the stress state (membrane and bending). Membrane compression forces are favorable for concrete, and tensile forces are resisted by the reinforcement and/or cables.

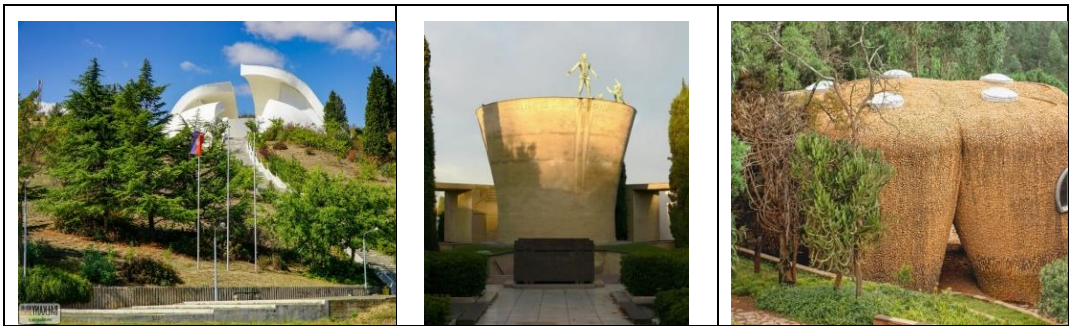
Monolithic construction requires the use of scaffolding and formwork, when inaccessible depressions are bridged; they are expensive and slow down construction. With the improvement of the span bridge construction technology, this problem has been overcome. Instead of an earlier method of construction which used fixed scaffolds resting on the ground, mobile and suspended scaffolds were introduced. Suspended scaffolds rest on bridge piers and are efficient when the span structure is located high above the terrain to be bridged. They are made from prefabricated segments, at a "work station" from which, after prestressing, they are pushed by hydraulic presses over the columns into a new position. Prestressed concrete and prefabricated construction are used for beam bridges, as efficient. It turned out that the expedient method of construction is prefabricated - monolithic. This construction method is also popular with high-rise buildings. By the stiffness of the carrier, i.e. reinforcement in the zone of the supports results in more cost efficient constructions, because it is possible to cover the negative moment surface in the upper zone with significantly less steel than the positive moment in the lower zone.

For the Olympic Games stadium in Rome in 1960, P. L. Nervi applied the prefabricated construction. The Palace of Sports, consists of 1620 elements, with only 19 different types. One element was applied 108 times, and peripheral elements were repeated 36 times. The spherical dome is formed by 1008 elements of 9 types. Nervi has patented ribbed floor slabs with ribs in the direction of the main stress trajectories [9]. Figure 8 show the details of this creation and the harmony of the structure from outside and inside..



Figure 8. Palazzetto dello sport, Rome, P. L. Nervi with A. Vitellozzi, 1956-5, [9].

The variety of buildings where thin concrete shells and other concrete sculptural forms were used for special functions as is shown in figures 9, 10 and 11. Memorial structures were a great challenge to express the sculptural possibilities of concrete through them. Although innovative materials are often used today for sculptural forms, concrete as a material has survived and is still used in memorial structures until now, as evidenced by the memorial park in Ethiopia, which is being built in 2023. The monumental memorial-ossuaries represents the great concrete architecture and symbolic originality.



Figures 9, 10 and 11. Memorial ossuary in Veles, N. Macedonia, Lj. Denković, S. Subotin, R. Folić, 1979; Monument-ossuary to the fallen Parisians, Bologna, Italy, P. Bottoni, 1959; The Meles Zenawi Memorial Park, Addis Ababa, Ethiopia, Studio Other Spaces, Fasil Giorghis and Vogt landscape architects, 2023.

Engineering structures such as the bridge with its attractive silhouette also stand out with their elegance. Top achievements were also made in the construction of bridges that have technical, utilitarian, and aesthetic values [1]. The Djurdjevića Tara Bridge, designed by M. Trojanović, although it was built before the World War II, it is still shown as an example of an elegant crossing solution in many books and magazines. It is really an exceptional achievement in reinforced concrete (Figure 12). Footbridge Kingsgate across the River Wear in Durham is still a striking, modern, reinforced concrete construction. It was the last personally designed structure of Ove Arup in 1963 (Fig. 13).



Figure 12. Djurdjevica Tara Bridge, Montenegro, M. Trojanovic, 1939.

Figure 13. Kingscross footbridge, Durham, U.K., O. Arup, 1963.

The bridge across the Danube river near Beška was designed by B. Žeželj, It was built by using the cantilever "balance" method (shown in the process in Fig. 14, and had a record mid span of 211 m. During its construction, a bridge with a larger span was built in Australia, unfortunately. The concrete bridge of the arch system, connecting Krk island to the mainland, designed by I. Stojadinović, with a span of 390 m, was for a long time the longest span in the world (Fig. 14). During the construction of this bridge, the cantilever method of construction was also used, which avoided expensive scaffolding considering the nature of the obstacle.



Figure 14. Bridge Krk-St. Marc-mainland, Croatia, I. Stojadinovic, 1980.

P.L. Nervi, E. Torroja and F. Candela improved structures with the use of concrete built *in situ*, which required a large expenditure of wooden formwork and scaffolding [23]. However, some shells of double curvature, such as, for example, a hyperbolic paraboloid (hyppar) can be made by formwork from flat - straight boards (Fig. 15, 16, 17 and 18). Concrete shell roofs were, however, built in countries rich in wood, which was used for formwork and scaffolding. As mention above, the most intensive use is related to the 50s and 60s of the 20<sup>th</sup> century [8]. After that, the introduction of prefabricated construction for these structures began, and the use of new materials, too.

The most ambitious cover of E. Torroja, perhaps of his entire career, was that of the Táchira club in Venezuela, carried out together with the architect Fruto Vivas. For this project, this scale model was made at the Institute of Construction Sciences in Madrid. These work seemed to resume his career in the world of architecture, but Eduardo Torroja died in 1961 before it was completed. Another world known Spanish and Mexan architect was F. Candela Outerño. His major contribution to architecture was the development of thin shells made out of reinforced concrete, popularly called *cascarones*. Candela was real admirer of



reinforced concrete in the shape of a dome or shell. That is why he had a great influence on the work of his student Santiago Calatrava. The above-mentioned creators should be joined by the extremely successful team of architect L. Costa and constructor O. Niemayer. In the brand new city of Brasilia, they were free to develop concrete architecture to unimaginable proportions. The aforementioned creators should be joined by the extremely successful team of architect L. Costa and architect and constructor O. Niemayer. In the brand new city of Brasilia, they were free to develop architecture from concrete to unimaginable proportions. Niemeyer himself has many buildings that border on exhibitionism.



*Figure 15. Scale model of Táchira club, Venezuela, E. Torroja*

*Figure 16. Los Manantides Restaurant, Xachimica, Mexico, F. Candela, 1958.*

*Figure 17. Hemisphere of Aquarium, Valencia, S. Calatrava and F. Candela 1998.*

*Figure 18. Oscar Niemayer Museo, Curitiba, Brasil, O. Niemayer, 2006.*

Some concrete structures built in Serbia through the originality of implemented solutions and building technology can be ranked among the global achievements. This should encourage the young generations, to follow the creative efforts of the previous generations in the field of concrete structures.

Apart from the bridges, this refers to the Fair Hall 1, construction designed by B. Žeželj, and Fair halls 2 and 3 constructed by M. Krstić in Belgrade, which are assessed to be the world's top design creations in concrete (Fig.19). The prestressing IMS system is known in our country and worldwide. It has been used to construct the double prestressed beams on the JAT hangar 2 on the Belgrade airport, and the "Arena" roof on New Belgrade, designed by M. Ivković et al. The TV tower on Avala by M. Krstić destroyed by NATO in 1999 belonged to the category of exceptional designs, too. New tower, on the same location has been built from steel.



Figure 19. Panoramic view of Belgrade Fair - Hall 1, B. Žeželj, Halls 2 and 3, M. Krstić, 1957.

However, even younger architects and constructors could not resist the attraction of concrete, as evidenced by the buildings shown in Figures 20, 21 and 22, with extraordinary aesthetic values. In the XXI century, several exceptional creators did not completely renounce the joy of creating in concrete. Although in many of their works they use the most modern materials and technologies, they also designed bold concrete structures.



Figure 20. Meiso no Mori Municipal Funeral Hall, Kagengahari, Japan, T. Ito, 2006.

Figure 21. Heidar Aliyev Centre, Baku, Azerbaijan, Z. Hadid, 2012.

Figure 22. Sarpi Border Checkpoint, Georgia, J. Mayer H. Architect, 2011.

#### 4. FINAL NOTES AND CONCLUSIONS

The previous analysis and the presented superior achievements, with exceptional aesthetic values, confirm that concrete is undoubtedly the material of the 20<sup>th</sup> century, but also could be the material of the future [12] and [13]. Intensive theoretical and experimental research contributed to this. Great progress has been made with the development of high-strength concrete. Today, it is relatively easy to achieve concrete with strength of 80 MPa and higher quality. Combined materials (coupling of concrete with concrete, steel or wood) and the use of concrete from recycled aggregates are increasingly being used. The application of "smart" materials in constructions has also been worked on. Concrete is indispensable for the construction of foundations and structures in contact with water.

In designing, improving conceptual design will be developed. In addition to EN 1992 for design, guidelines for design and construction are being improved, such as in the International Federation for Concrete *fib*, the American Concrete Institute and others. In order to increase the durability of CS, protection against corrosion in the design and application of special types of reinforcement and protective measures is under way. Of particular importance is mitigating the impact of natural hazards on CS. In the future, the impact of climate change on the behavior of CS will gain importance. A very topical analysis of structural robustness (prevention of chain collapse) was introduced in EN 1990:2002, because of possible incident actions. In doing so, complex non-linear analyzes must be implemented, which require the use of computers and software.

One of the goals of this work was precisely to point out the strength of talent, sound construction logic and intuition that guided the builders creating incredibly striking concrete forms, with no or minimal application of modern computer techniques and other modern technologies.

## REFERENCES

- [1] Folić, R. **I beton ima dušu-dometi betona u graditeljstvu**, *Pristupna beseda, VANU Godišnjak 2014*, N. Sad, 103-117, 2015 ISSN 1452-2268
- [2] Torroja, E.: **Philosophy of Structures**, University of California Press, Berkley and Los Angeles, 1962.
- [3] Kurtović Folić, N. Folić, R. **Cooperation Between Architects and Structural Engineers in the Design of Complex Reinforced Roof Structures<sup>1</sup>**, *Contemporary theory and practice in Construction XII*, (B. Antunovic, ed.), May 20-21, Banja Luka, Univer. of BL, Fac. of Arch, CEG, 455-470. B. Luka, 2018.
- [4] Faber, C. **Candela und seine schalen**, *G. D. W. Callwey*, Reinhold PC, 1963
- [5] Rey-Rey, J. **Nature as a Source of Inspiration for the Structure of the Sydney Opera House**, *Biomimetics*, 7, 23. MDPI, 2022; <https://doi.org/10.3390/biomimetics7010023>
- [6] Nowak, A, Rokicki, W. **Bionic forms in search of structural models in architecture**, *MATEC Web of Conference*, 174, 03020 (2018) ECCE 2018
- [7] Chilton, J., Chuang, C. C. Rooted in Nature: Aesthetics, Geometry and Structure in the Shells of Heinz Isler, *Nexus Netw J.* 19: 763-785, 2017.
- [8] Meyer, C., Sheer, M.H. (2005): **Do concrete shells deserve another look**, *ACI Concrete International*, October, 2005, pp. 45-50.
- [9] **The Works of Pier Luigi Nervi**, *F. A. Praeger*, New York, USA, 1957.
- [10] Nervi P. L. **Architecture Aesthetics and Technology in buildings**, *Haward University P*, Cambridge, 1965.
- [11] Kurcjusz, M. Stefanska, A. Dixit, S. Starzyk, A. **The interdisciplinary designing in form, funcion, and structure coherency**, *ACTA Sci. Pol. Architectura* 21 (3), 3-13, 2022.
- [12] Hu, N. Feng, P. Dai, G-L. **Structural art: Past, present and future**, *Engineering structures*, 79, 2014; 407-416.
- [13] Wang, S. Kotnik, T. Schwartz, J. **Redefining structural art: A neuroaesthetics Perspective on the art of structural design**, *Springer, Architecture, Structures and Construction*, no. 2, pp 3-16, 2022.

## GEOMETRY AND FORM IN FUNCTION OF INTERIOR SPACE AND OUTER APPEARANCE

Jovana Vukanić<sup>1</sup>, Vladan Nikolić<sup>2</sup>, Jasmina Tamburić<sup>3</sup>, Olivera Nikolić<sup>4</sup>, Sanja Spasić Đorđević<sup>5</sup>

### Abstract

*The problem presented in the paper is the analysis of the spatial, formative and constructive assembly of geometric structures through practical application in architectural design. The connection between the interior and exterior space represents an inexhaustible source of inspiration, a specific approach and a different way of shaping the object. Through the transformation, combination and mutual position of geometric shapes, an interior space is created that directly affects the external appearance of the building. Geometry as the language of architecture is one of the main guidelines for designing. The question arises, is geometry really the essence of form? Designing a form that can be build requires defining the relation between geometry and form in terms of a particular medium. Therefore, it is important that architects in their work apply different materials in a wide range of tools that are applied in the design process. Geometry is essentially the language of architecture, so the connection between geometry and architecture is inextricable. Digital design tools that are an integral part of computer technologies have opened up many possibilities in the design of architectural objects. Curvilinear architecture, free geometry, which is becoming more and more popular in the world, is being implemented. These possibilities led to the creation of new non-standard objects in architecture. Current research of form in architecture requires comprehensive knowledge, perception and constructive processing of geometric shapes, and is based on the use of new computer technologies. The goal of the research is to consider the possibility of practical use of geometric shapes in the design of usable spatial structures.*

**Key words:** form, shape, geometry, computer technologies, digital design

---

<sup>1</sup> PhD student, Faculty of Civil Engineering and Architecture in Niš, jovanavukanic96@gmail.com

<sup>2</sup> Associate Professor, Faculty of Civil Engineering and Architecture in Niš, vladan\_nikolic@yahoo.com

<sup>3</sup> Assistant Professor, Faculty of Civil Engineering and Architecture in Niš, ministro@yahoo.com

<sup>4</sup> Junior teaching assistant, Faculty of Civil Engineering and Architecture in Niš, o\_milosavljevic@yahoo.com

<sup>5</sup> Research associate, Faculty of Civil Engineering and Architecture in Niš, sanjaspasocdjordjevic@gmail.com

## 1. INTRODUCTION

The design of spatial forms that show the developmental quality of complex systems is already theoretically and practically present in architecture, not only in the last decades, when the theory of complexity enters the architectural sphere more significantly, but also in much earlier periods.

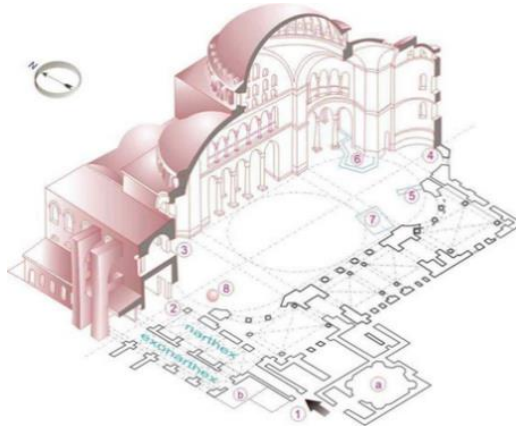
Modern architecture, based on a rational scientific approach to spatial and constructive problems, finds its support in geometric rules. The return to the visualization and representation of modern geometry through computer graphics enabled the visualization and structural representation of non-linear processes, opening up new areas of geometry. A broader, more complex framework of geometry appears, with a change in the very character of geometric form, not as static and closed, but as dynamic and open structures. [1]

Every architectural work is based on a solid scientific basis and that is its main component for such a work to survive. Apart from the scientific, the aesthetic component is also very important, which is the product of scientific analyzes, evidences and conventions with the architect's ability to create an impressive final model of the building, showing artistic freedom and leaving personal mark. The choice of material for the final process of an architectural work also goes through an analysis from a scientific aspect in order to see all the physical and mechanical properties of a particular material, its durability, quality, but ultimately perform an analysis of the aesthetic effect. When creating an architectural work, in addition to the creator's personality, his individuality and affinity, his knowledge and skills are also important and how he transfers it to the work. It is possible to see and experience an architectural work, it is possible to separate certain elements from nature or the environment, but it is a part of the universe that is complex and we feel it with the mind.

## 2. ARCHITECTURAL FORM

In order to analyze the shape, we must first experience, experience and feel it, because that also affects the properties of the shape and determines them. Geometric shapes are part of the real world, but we are subjects with our own world, our own feelings and thoughts, so it seems that the real world is eluding us. In fact, it exists, but we cannot catch it as it is because it exists beyond our interests. We are interested in when a geometric or any real element becomes an aesthetic architectural element, when the message of its essence as an ethical determinant turns into an aesthetic message, because it seems to us that this is less manifested in things and more in the established relation between them. [2]

The architectural form in the process of analysis, design and construction can be observed through three orthogonal projections, regardless of its complexity, it is always special and makes a unique composition. In one of the architectural compositions, each shape has its own characteristics that do not always coincide with the other parts of the composition, but affect each other through their connection within the structure. Therefore, the outer wall is basically also the side of the belonging facade, the horizontal parts of the section are the parts of the floor, and the contour of the section represents the shape of the facade (Figure 1.). This spatial relation of two-dimensional drawings determines a three-dimensional shape. [3]



*Figure 1. Floor plan, section and 3d model of the building*

Geometry and architecture are in a direct and inseparable relationship, which is clearly visible in this case. The connection between these two branches is necessary, and with rational and skillfully used geometric surfaces, with special attention paid to proportions and aesthetics, a successful design is inevitable. Architects, through geometric surfaces and symbols, ensure the durability of the monumental architectural complex. By applying geometric surfaces in practice, quality results were achieved. Some of the most famous works of world architecture were created by the combination and mutual arrangement of geometric shapes.

### **2.1. The use of geometric shapes in the design of usable spatial structures**

The dome stands out in the Byzantine ideas of the spatial solution and its place is in the center of the horizontal plan. The beauty of Byzantine architectural forms is explained by the geometry of forms and technical solutions in the notion of space that permeates irrational numerous relations. (Figure 2.).



*Figure 2. Geometrized model - King's church, Studenica*

The tendency for designing elements that are symmetrical or applying the pairs of elements in sacral objects is justified by the fact that similar elements give

pleasure to the human eye. Any irregularity and inequality would distract a person and ask questions to which he as an observer would not be able to give an answer. In Byzantine churches, we can notice the uniformity of the domed arches, which contribute to the beauty and at the same time the stability of the construction. With the harmonious geometry of the structure elements, a master builder primarily contributes to its stability and security, while creating harmonious whole through which the beauty of the shape of the object stands out. Not every constructive element on the temples has to be beautiful itself, it is important that in combination with the others it is harmoniously connected and together they form a beautiful uni. [4]

In Byzantine churches, shapes are a material and integral part of the building. Observing the object, we start from the basic geometric solids and single out the walls as a church envelope, lines as its contour or a place of change of material, shape, structure, color. In architectural drawing, these basic elements have technical and aesthetic properties. The shape is not enough to see, it needs to be recognized. Recognition is the process of matching / identifying with some familiar shape and configuration. A shape can be represented by the essential elements that make it up, rather than by drawing or rendering all the parts of which it actually consists. These parts are important because they send us messages about the whole that we feel but it does not exist. We experience the whole because it is correct and simple and we have seen it many times, so only certain knowledge allowed us to form it in our heads. [5]

When looking at a certain object, the form is first perceived, and later further classification and recognition occurs. The geometry of the form directly affects the experience of their character. For example, round and slender figures are judged as gentle, while sharp-angled and dark ones create the impression of roughness and gloom. [6]

The formation of objects from arbitrarily complex geometric forms is what attracts most architects, the spatial complexity and the complexity of the form of objects are solved by adequate materials and substructure. Especially important is the connection of these elements, their material characteristics, weight, resistance, as well as their mutual relation and the action of the structure as a whole. This kind of design creates unique spaces whose form can be defined, designed according to the needs of the space and its users and different external influences (Figure 3.). [7]



Figure 3. Renzo Piano Building Workshop, The Pathé Foundation, Paris, 2006–2014

Parametric design provides architects with a set of tools to expand cognitive ability and operational ability in complex forms of design, calculation, parametric design and modeling poses new challenges of how to practically use this new design method and what consequences it brings. It requires knowledge in the field of computing and mathematics, it is often necessary for an architect to think about two things at the same time, about the work he creates, its design, shape and geometry, and the way he intends to design and realize it. Parameterization increases the complexity of the design task because designers must model not only the artifact being designed but the conceptual structure of the entire project. [8]

The application of complex geometric form in architecture is not necessarily related to new technologies and new media of presentation, but can also be found in projects that were created as a product of intuitive spatial thinking, relying on sophisticated mechanisms of human perception, intelligence and creativity, which in modern science have received new verification within the principle of computational equivalence.

### **3. CONCLUSION**

In early architecture, whose language and norms remain inextricably linked to constructive geometry regardless of their transformation, there is a secret history of divergent relations: turning against one's own geometric truth. The discovery of the mathematical method of plane perspective and the subsequent consolidation of architectural drawing and geometry was not only the basis of the transformation of architecture but also a hint of modernity. The above examples show that we do not perceive shapes as they are, but as we see them and how they are integrated into the context, and that this relationship significantly affects the perception and experience of the object.

As people over time became more aware of how their psycho-physical condition is affected by the environment in which they live, stay and work, architects began to create more and more natural forms, to take into account the problems of environmental protection, the connection between architectural forms and nature, urban design and the most important feeling of a person while he is in that place.

Apart from the architectural work as a whole, formed by a series of architectural elements and their mutual relations, the user's experience is also influenced by his expectations. According to Bernard Tschumi, the use of architectural space is the intrusion of one order into another, "a delicate act that disrupts the balance of a balanced geometry". It defines the character of the space as much as the space itself defines the events in it. [9]

In order to achieve a certain effect or convey a message, we often view the church as a complex set of forms. By merging geometric entities, rectangles and squares, prisms and cubes or other geometric shapes, an assembly is created in which all the elements act as one whole and on the other hand the initial, basic shape can be recognized. Thus, in Byzantine churches, domes, vaults, pillars, window openings, walls represent separate elements of the building and with their relation they create a stable whole in a constructive and aesthetic sense. In considering the architectural work, the phenomenon of the predominance of shapes is known, which means that in the composition of curves, curved volumes, a simple rectangular shape is first noticed, but also vice versa.



Geometry made it possible to understand the essence of architecture as a whole and to develop it according to the norms using its language independently of the transformation of reality.

## REFERENCES

- [1] Čektarević Rada: Univerzalnost kompleksnosti od geometrijsko prostornog koncepta modernizma do suvremene arhitektonske forme. *Prostor*, UDC 72.036:72.01, 64-72, Zagreb, 2008.
- [2] Martinović Uroš: **Svet arhitekture**. *Univerzitet u Beogradu*, Beograd 1980.
- [3] Folić Ljubiša: **Arhitektura hrama**. Eparhijska radionica za umetničko projektovanje i oblikovanje Beograd, Beograd 2012/13.
- [4] Bjelić Igor: Tipološke i konstruktivne karakteristike lukova i svodova sakralnih objekata na tlu srednjovekovne Srbije. *Univerzitet u Nišu, Građevinsko-arhitektonski fakultet*, 2016.
- [5] Kurtović-Folić Nađa: Obrazovanje i stvaralačke mogućnosti graditelja u kasnorimskom i ranovizantijskom period. Univerzitet u Nišu, 2011.
- [6] Marković Slobodan: **Opažanje dobre forme**. *Filozofski fakultet Univerziteta u Beogradu*, Beograd, 2007.
- [7] Januszkiewicz Krystyna, Kowalski Karol: **A Non-Linear Shaped Architecture In Urban Space**. *Architecture Civil engineering Environment*, The Si lesian University of Technology, No.02/2017, 2017.
- [8] Gursel Dino Ipek: **Creative design exploration by parametric generative systems in architecture**. *METU*, Journal of the Faculty of Architecture, DOI: 10.4305/METU.JFA, , 207-224, Turkey, 2012.
- [9] Tschumi Bernard: **Red is not a color**. *Rizzoli*, New York, 2012.

## HYDROTECHNICAL TUNNELS AT DAMS

Zlatko Zafirovski<sup>1</sup>, Marija Petkovska<sup>2</sup>

### Abstract

*Performance of the construction work for each structure needs to be in accordance with a project documentation, for which a construction permit has been granted. Sometimes there's a need for a change of basic design, not only for rough construction work, but for all construction works.*

*In this paper hydrotechnical tunnels are mainly covered. First, there is a description of construction of one diversion tunnel, then the explanation of construction of two hydrotechnical tunnels from dams with accumulation, these dams are still being built in North Macedonia. The main part of this paper thesis is comparison between the changes in the construction work and the design of the tunnels.*

**Key words:** *Structures, Diversion tunnel, Project documentation, Performance, Comparative analyses*

---

<sup>1</sup>Associate professor, Ss. Cyril and Methodius University in Skopje, Faculty of Civil Engineering Skopje, zafirovski@gf.ukim.edu.mk

<sup>2</sup>Associate engineer, CEI, petkovska.m@hotmail.com

## 1. INTRODUCTION

### 1.1. Scientific justification of the topic

The standard process for designing dams involves the occurrence of certain structures during performance planning. A dam with accumulation contains the following structures: dam body, injection tunnel, diversion tunnel, entrance construction, spillway, etc.

The diversion tunnel is located below the dam body and it is converted to dam outlet during the period of exploitation.

Each structure is exposed to numerous impacts, caused by a variety of reasons, which results with execution difficulties, followed by prolonged deadlines. Therefore, a need of additional financial resources arises and finally, the project documentation suffers certain changes [1,2].

### 1.2. Purpose of the investigation

The purpose of this paper, is comparing different diversion tunnels in their construction phase, with more thorough analysis of few characteristic problems that occur during the construction works. These examples, can contribute in future designs by predicting their appearance in the design phase. In this way, these problems will be avoided during the construction works performed on hydrotechnical tunnels [3,4].

## 2. ANALYSIS OF HYDROTECHNICAL TUNNELS

### 2.1. "Otinja" Dam

The "Otinja" Dam is located in the eastern region of the Republic of North Macedonia, more accurately, at a distance of 300 m over the town of Shtip, and in front of the entrance of the River Otinja. The barrier site is consisted of hilly terrain, with a good storage space in the river bed, which makes it an ideal location for building a dam. The Otinja River waterflow will be used to fill the accumulation.

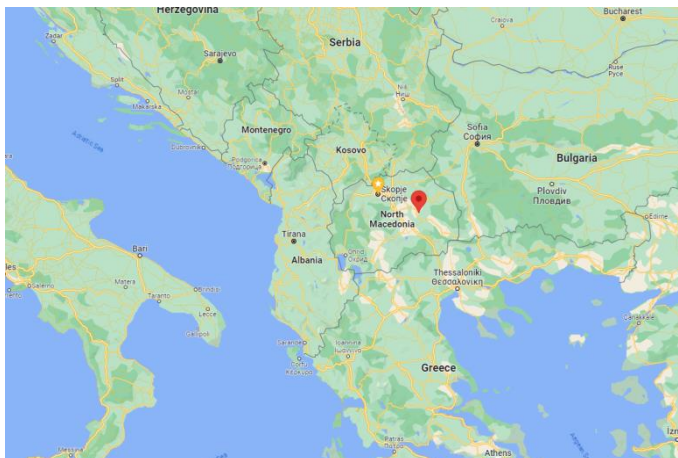


Figure 1. Location of the dam on the territory of R.N. Macedonia, Shtip

The dam belongs in embankment (rock fill) type of dams, built from rocks of different sizes on the outer side and a clay core in the middle. The dam has a height of  $H=32.50$  m and a total length of  $L=167.79$  m.

The "Otinja" Dam is intended to provide flood protection, regulation of the catchment area of the River Otinja, change of climate conditions in the town of Shtip, water supply with technological water for watering parks and greenery, recreation of the population and development of tourism [5,6].

### 2.1.1. Design of the diversion tunnel

The diversion tunnel is located on the left bank of the River Otinja, with the length of  $L=186$  m, elevation varying from 307.00 m MSL\* (at the entrance) to 303.20 m MSL (at the exit) and a longitudinal slope of 2.42 %.

The alignment of the tunnel is composed of two straight sections and one circular curve with radius  $R=60$  m. The light opening of the tunnel pipe has a diameter  $D=1.7$  m and thickness of the concrete cover of  $d=0.40$  m.

The purpose of the tunnel is to evacuate the River Otinja waterflow during the construction phase. In the exploitation period, the tunnel will be converted into a dam outlet. At the tunnel exit, a hydrotechnical structure is planned for manipulation of the water discharge. The tunnel pipe ends with a gate valve, which is intended for incidental, partial or complete emptying of the accumulation [9,10].

The dam outlet is consisted of three sections:

- The first section is an entrance construction - a vertical shaft with a square shape with dimensions  $3.0 \times 3.0$  m and a height of  $H=3.85$  m. The square section turns into a circuit pipe with a diameter of  $D=1.7$  m at a height of  $H=3.85$  m.
- The second section is the circuit pipe, with a constant cross-section along the entire length of  $L=156.6$  m. The internally placed pipe has a diameter of  $D=1.70$  m and a concrete cover around the pipe with dimensions  $a=2.50$  m and a height of  $h=2.70$  m.
- The third section is an exit structure, where the pipe has a diameter of  $D=400$  mm, length of  $L=4.60$  m, and it is placed inside the outlet structure and the water discharge equipment.

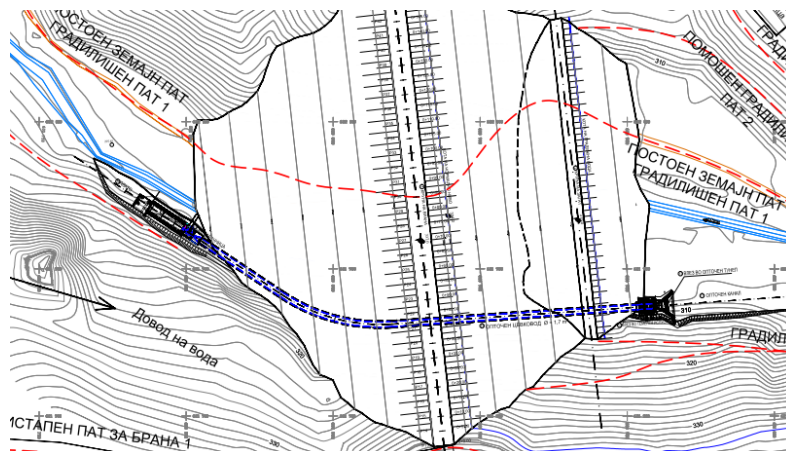


Figure 2. Situation of diversion tunnel

\* Mean Sea Level (MSL) is the datum for measurement of elevation and altitude.

### 2.1.2. Construction of a tunnel

#### 1) Placement of steel stiffening rings.

In order to provide better contact surface between the concrete and the steel pipe placed inside, steel stiffening rings are preferred. These rings are placed at a length of 3 m along the pipe. In the first phase, the steel pipe is lifted and placed in the appropriate place using a crane. In addition, anti-corrosion protection is needed for the pipe, as well as control of the welds on the steel rings [7].



*Figure 3. Welding of steel rings in a factory*



*Figure 4. Installation of steel pipe*

#### 2) A change in the technical solution has been made.

In order to ease and fasten the execution, cones and elbows for joining in the entrance construction were foreseen.



*Figure 5. Elbow installation for the connection of entrance construction and steel pipe*

The entrance cone is performed as a steel cover with thickness of  $d=7.1$  mm, and dimensions  $\phi 2500 / \phi 1720 \times 3850 \times 7.1$  mm. During construction phase, the cone serves as a formwork for the concrete layer, and later, in the exploitation phase, it's used as protection against adverse effects (cavitation) in the concrete construction. The entrance part of the cone is performed in round shape, instead of rectangular, in the purpose of easier performance and a better connection with the steel pipe.



*Figure 6. Installation of a cone for entrance construction*

Diameter of the entrance part equals  $D=2500$  mm, i.e.  $D=1700$  mm at the junction with the elbow. This makes the shape of a truncated cone with dimensions  $\phi 2500/\phi 1700 \times 3850$ .

### 2.1.3. Software analysis of the tunnel

The software package SAP 2000 was used for conducting the static analysis of the diversion tunnel. The calculation follows the rules given in the Eurocodes. Mathematical 3D model of the construction is made by using appropriate shell elements and realistic material characteristics. The stress-strain analysis is conducted by the finite elements method [8,11]. Final goal of the analysis is calculating the necessary reinforcement in all concrete sections, and control of the limit states (ULS and SLS)\*.

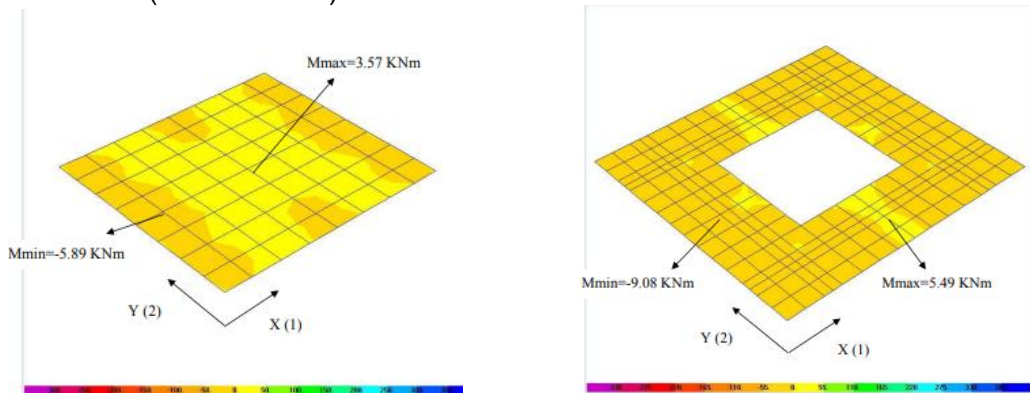


Figure 7. Display of M11 envelope moments in plate

**Comment:** The opening in the plate, causes a higher intensity of the bending moments compared to those in plate.

Concrete class of MB30 and ribbed reinforcement with designation RA 400/500-2 are used. A graphic part is created, drawings in which the formwork plan and the reinforcement plan can be shown in detail separately for all positions of the tunnel [12,13].

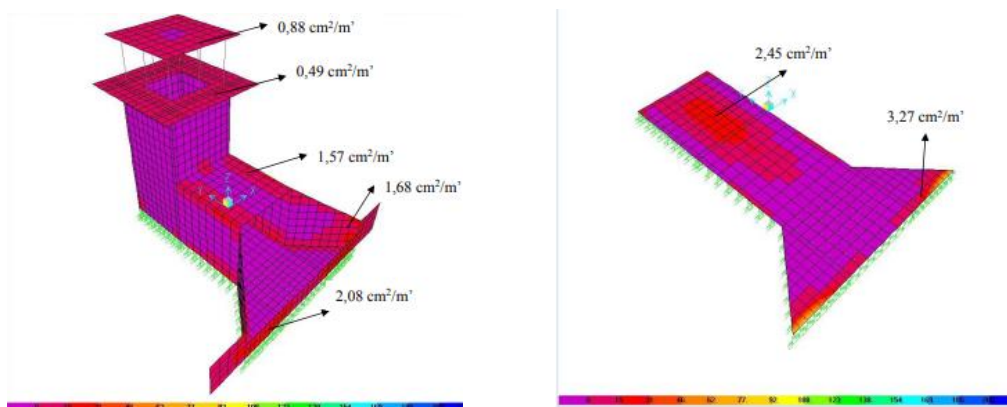


Figure 8. View of reinforced concrete for entrance construction

\*Limit state design requires the structure to satisfy two principal criteria: the ultimate limit state (ULS) and the serviceability limit state (SLS)

**Comment:** Considering the relatively small influences, the entire construction is structurally reinforced with: RA  $\varnothing 12/15$  cm with area of  $A_a = 7.54 \text{ cm}^2/\text{m}'$ .

## 2.2. “Konsko” Dam

The “Konsko” Dam is located at 20 km from town of Gevgelija. The accumulation should provide water supply to the Municipality of Gevgelija and irrigation by pumping for 8000 ha of agricultural land.

This project, also will contribute in improvement of the hydrological condition of the Dojran Lake.

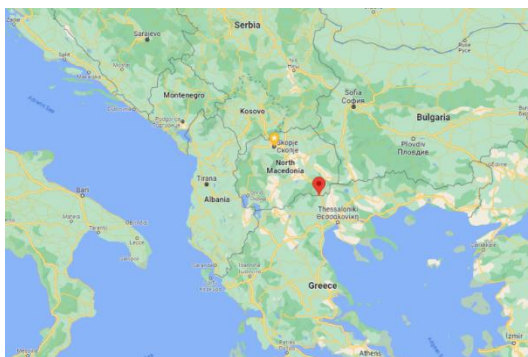


Figure 9. Location of the structure in the territory of R.N. Macedonia, Gevgelija

The dam belongs in the embankment (rock fill) type of dams, built from rocks in different sizes on the outer side and a central asphalt core and three filter layers.

The dam is designed with an external spillway, injection tunnel, diversion tunnel and entrance construction. The height of the dam is  $H=80.0$  m and will be composed of a total of  $\approx 1\,400\,000 \text{ m}^3$  of embankment material.

The area of the accumulation equals 80 ha and it is predicted to contain  $21\,000\,000 \text{ m}^3$  of water.

### 2.2.1. Design of the diversion tunnel

The diversion tunnel is designed in the bottom of the embanked "Konsko" Dam. The tunnel is positioned along the left bank of the valley, which will be placed under the dam body in the exploitation period.

The tunnel consists of a total of 40 parts, two plugs, an entrance or mouth of the tunnel, a slab, wings, a frame and a valve.

The tabular valve has dimensions of  $4.0 \times 4.0$  m for entrance construction for diversion tunnel. This valve is needed for the start of re-adaptation of the tunnel into a dam outlet.

The total length of the tunnel is  $L=269.87$  m and is designed with a longitudinal slope of 2 %.

The external dimensions of the diversion tunnel are chosen in relation to the loads acting upon the tunnel. The light opening of the tunnel has constant dimensions:

- width  $B=4$  m;
- height  $H=4$  m;
- diameter = 2 m.



The thickness of the tunnel the thickness of the concrete tunnel lining is variable, depending on the loads acting upon it. Therefore, three types of the thickness of the concrete tunnel lining are constructed:

- type 1:  $t/d = 60/80$  cm;
- type 2:  $t/d = 80/100$  cm;
- type 3:  $t/d = 90/100$  cm.

where:

- t - thickness of the vault and vertical walls and
- d - thickness of floor plate.

The exit structure is designed as a reinforced the thickness of the concrete tunnel lining with variable dimensions along the length.

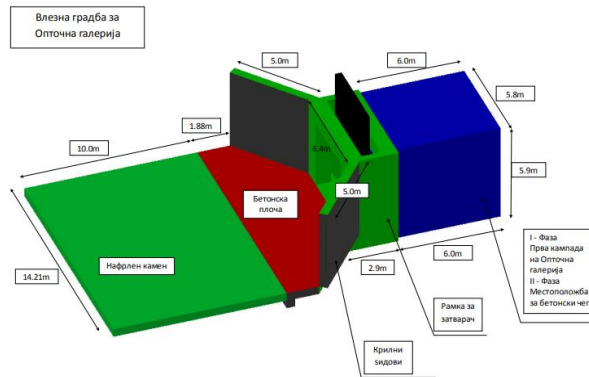


Figure 10. Entrance construction for diversion tunnel

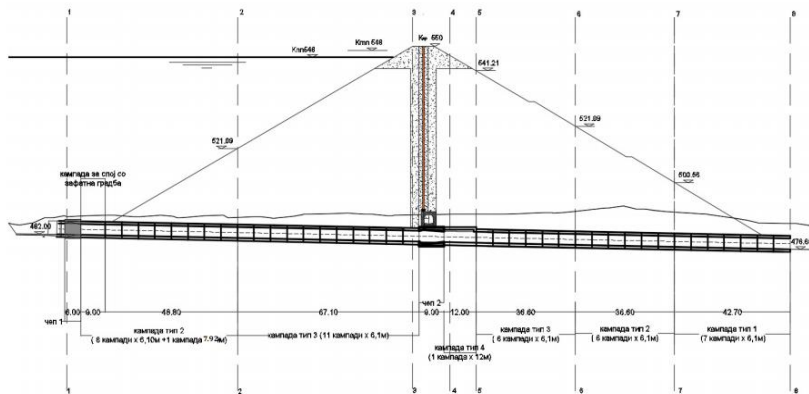


Figure 11. The diversion tunnel in cross section of the Dam

## 2.2.2. Construction of the tunnel

- 1) Underground water has occurred.  
As a solution, two wells with a depth of  $D_f=2.0$  m were drilled. The water is pumped out of the wells and then is taken from outside the structure location and diverted into the river bed of the River Konsko.

The water must be removed from the excavated section, because it creates problems during the funding structure and adversely affected the working conditions.



*Figure 12. The diversion tunnel in construction*

- 2) Occurrence of fault zones - poor material on which to build.  
For this reason, a bigger/deeper excavation was made, in order to get into a soil material that meets the required bearing capacity. For the purpose of funding the whole tunnel length at one foundation level, lean concrete MB20 with variable thickness was used.



*Figure 13. Diversion tunnel exit*

### 2.2.3. Software analysis of the tunnel

The software package “Robot Structural Analysis” is used for the static and dynamic analysis of this diversion tunnel. The mathematical model contains the tunnel structure and the rock foundation, represented by the appropriate material characteristics. The weight of the dam embankment on the tunnel is applied as a load, so it is taken into account in the analysis.

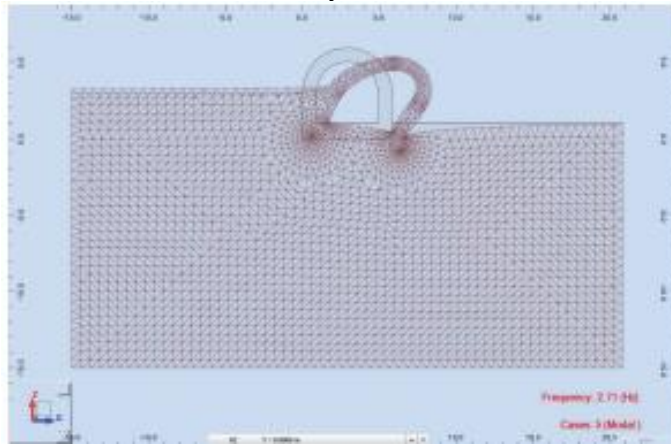


Figure 14. First period - translation,  $f=2.71$  Hz;  $T=0.37$ s

The stress-strain analysis is conducted by the finite elements method. Final goal of the analysis is calculating the necessary reinforcement in all concrete sections, and control of the limit states (ULS and SLS)\* according to the Rulebook for CRC'87\*.

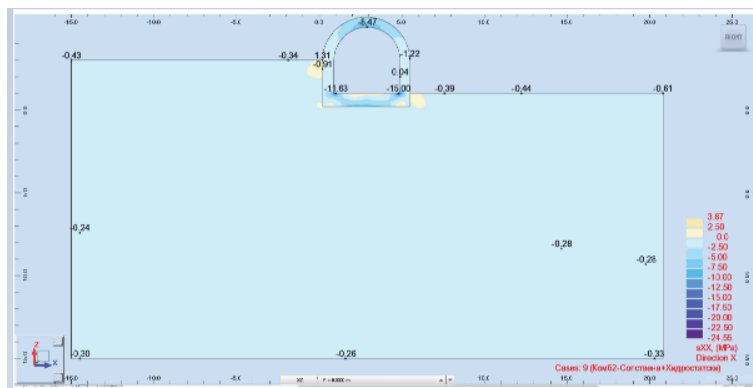


Figure 15. Stresses  $\sigma_x$  - Comb.2\*

\* CRC'87- Rulebook for concrete and reinforced concrete from 87

\*Limit state design requires the structure to satisfy two principal criteria: the ultimate limit state (ULS) and the serviceability limit state (SLS)

\*Comb.2 – (1.6) self weight + (1.8) hydrostatic pressure

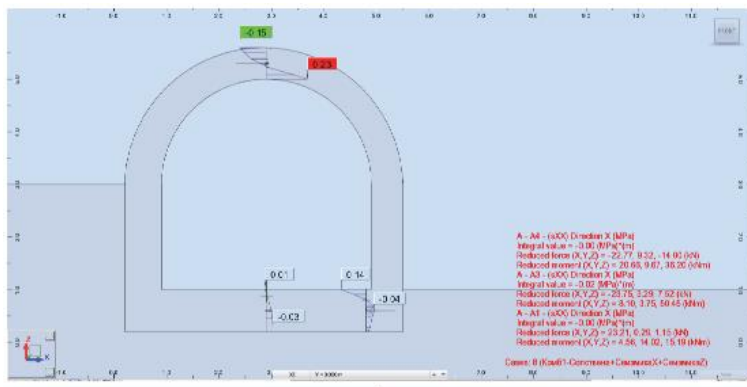


Figure 16. Bending moments and axial forces, sections - Comb.1\*

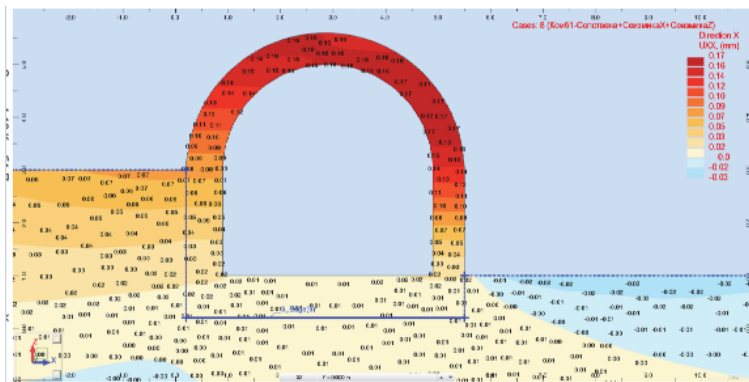


Figure 17. Displacement in X direction - Comb.1\*

\*Comb.1 – (1.3) self weight + (1.3) seismic X + seismic Z

### 3. RECOMMENDATIONS AND CONCLUSIONS

According to the previously mentioned differences in geometry and size, between the two diversion tunnels, a different amount of reinforcement and concrete for the tunnels construction is expected.

Considering that the “Konsko” Dam is 2.6 times larger than the “Otinja” Dam, it requests a larger diversion tunnel, following larger cross sections and quantity of material, more constructive positions, etc.

It is interesting to mention that although both tunnels differ in size, they were built in approximately the same period of time. The easier and faster execution is a result of creating a better dynamic plan, hiring a greater number of workers, engaging better mechanization, better weather conditions, ect.

In order do decrease the number of changes during construction on site, we should strive for more realistic designs, which include more accurate and precise layouts, investigations and results. Also the quality of the the project documentation, in great amount, depends on the given deadlines for conducting the design.

The authors of this paper come up with the idea to analyze exactly this, thanks to the opportunity to visit the sites during the construction of these two structures and being able to encounter the performance difficulties and the given solutions. Sometimes, much better solutions were given during construction, opposite to the

design due to easing the performance of certain position. These solutions can contribute in future designs of such structures.

## REFERENCES

- [1] Jovo Kovacelic, "Savremeno Gradenje u podzemlju", Beograd, 2014 godine
- [2] Banjad, I., "Tuneli", Zagreb, 1986 godine
- [3] Vrkljan, I., "Podzemne gradjevine i tuneli", Gradzevinski fakultet u Rijeci i Zagrebu
- [4] "Prirucnik o gradzenju tunela", prevod, Beograd, 1969 godine
- [5] R. R. Proctor: „Fundamental Principles of Soil Compaction“, Engineering News Record, Vol. 111
- [6] B. H. Seed, I. M. Idriss: „Analysis of Soil Liquefaction: Niigata Earthquake“, Journal of the Soil Mechanics and Foundations Division, Vol.93, No. SM3, 1967.
- [7] Creager, W.P and Justin, J.D, (1955), "Engineering For Dam", John Wiley and Sons.
- [8] USBR, (1987), UNITED STATES DEPARTMNET OF THE INTERIOR, BUREAU OF RECLAMATION, "Design of Small Dams", A Water Resources Technical Publication.
- [9] USBR (1978), "Design of Small Canal Structures", United States Department of the Interior, Bureau of Reclamation
- [10] USBR (1967), "Canals and Related Structures", Design Standard No.3, United States Department of the Interior, Bureau of Reclamation
- [11] Concrete: A Pictorial Celebration, American Concrete Institute, 2004
- [12] Nadim NM., Arthem M., Structural concrete, Theory and design, third edition, New Jersey, 2005
- [13] Rulebook for Concrete and Reinforced Concrete, 1987

# ANALYSIS OF PHASES AND STEPS OF THE ISO 22370 STANDARD IN PLANNING AND DESIGNING SMART AND RESILIENT CITIES

Ana Stojanović<sup>1</sup>, Dejan Vasović<sup>2</sup>

## Abstract

*Cities represent places of socio-economic progress, urban culture and development of civil society, for the functioning of which a network of infrastructural facilities that provide the necessary services is necessary. Understanding social and economic vulnerability is essential to formulating resilience actions tailored to local needs. Over the past decade, urban resilience has gained importance because it represents one of the key pillars of sustainable development and especially in the context of the climate crisis and the increased risk of disasters. City resilience is the ability of city systems, businesses, institutions, communities and individuals to adapt and thrive, regardless of the chronic stresses and acute shocks they experience. Planning for a resilient urban future requires addressing challenges and creating solutions in a place-based, integrated, inclusive, risk-aware and forward-looking manner. This paper analyses and presents the phases and steps in the process of implementing the ISO 22370 standard in planning and designing smart and resilient cities, with usage recommendations and guidelines in the Republic of Serbia.*

**Key words:** ISO 22370, climate change, smart cities, urban resilience, planning

---

<sup>1</sup> PhD student, Faculty of Occupational Safety, anastojanovic810@gmail.com

<sup>2</sup> Associate Professor, Faculty of Occupational Safety, dejan.vasovic@znrfak.ni.ac.rs

## 1. INTRODUCTION

Floods, droughts, landslides and heat waves are just some of the many climate disasters facing cities and, with urban migration on the rise, the pressure on them has never been greater. The Intergovernmental Panel on Climate Change (IPCC) states in one of its documents that climate change leads to oscillations in the frequency, intensity, spatial extent, duration and timing of extreme weather and climate events and may lead to unprecedented extreme weather and climate events [1]. Climate change and disaster risk are strongly linked through the effects of climate change impacts on intensity therefore climate change disaster management policy must seek to address its root causes (mitigation) as well as manage their impacts (adaptation). Similarly, disaster risk reduction aims to reduce the risk of disasters and the adverse impacts of natural hazards [2].

Hyogo Framework for Action (HFA) lists five priorities of the global community for disaster risk reduction, the first of which calls on states and the international community to ensure that disaster risk reduction is a national and local priority with a strong institutional basis for implementation [3]. Ten years later, the adoption of the Sendai Framework for Disaster Risk Reduction 2015–2030 at the third United Nations World Conference on Disaster Reduction (VCDR) and its subsequent endorsement by the United Nations General Assembly in June 2015 marked the culmination of a process that formally started in the 70s of the twentieth century [4]. All global agreements adopted after 2015, namely the 2030 Agenda, the Paris Agreement on Climate Change, the New Urban Agenda (NUA), the Addis Ababa Action Agenda (AAAA) and the Agenda for Humanity, actually include elements of disaster risk reduction and resilience. The mentioned agreements point to the interconnectedness of global challenges and related risks [5]. Their implementation requires countries to address the underlying drivers of risk by encouraging risk-based investment and focusing on issues such as poorly planned urbanization, environmental degradation, education and poverty.

Considering the fact that disaster risk always manifests itself at the local level, local governance is crucial in the context of disaster risk reduction. Disaster risk reduction actions at the local level can be triggered by an event that opens a "window of opportunity" for building resilience. The experience of some countries shows that it is the disasters that occurred in facilitating the process of raising awareness about the risk of disasters of the past among local authorities [6]. Even where local governments have relevant powers to develop disaster risk reduction strategies or manage risk, limited capacity and resources hinder implementation [7]. In this context, a resilient city should recognize the need for water, energy, food and ecosystem management on which the Nexus WEFEE approach is based. The Water-Energy-Food-Ecosystem Nexus (WEFEE Nexus) approach emphasizes the interdependence of water, energy and food security and the ecosystems – water, soil and land – that support that security [8].

Building the resilience of cities requires addressing a multitude of factors, including infrastructure, supply chains, transportation and more. To this end, the International Organization for Standardization (ISO) has created standards to help cities in all these areas, providing international best practice and a common language to support actions, technologies, measurement and benchmarking.

## 2. METHODOLOGY

For the purposes of this work, an analysis of several online and printed sources related to the planning and design of smart and resilient cities was performed, among which the requirements of the ISO 22370 standard Security and resilience - City resilience - Framework and principles stand out. ISO's series of safety and resilience standards cover a range of aspects dedicated to helping cities and organizations weather disasters. The mentioned standard is aligned with key global agreements such as the United Nations 2030 Agenda for Sustainable Development, the New Urban Agenda, the Paris Agreement and the Sendai Framework. The forthcoming ISO 22371, Security and resilience – Urban resilience – Framework, model and guidelines for strategy and implementation, intends to help national and local authorities build their capacity to face new challenges arising from climate change and changing demographics.

## 3. RESULTS AND DISCUSSION

Developed by Technical Committee ISO/TC 292, Security and Resilience, the technical report outlines metrics and models as a framework for structuring urban resilience to assist local governments and other urban actors in their efforts to build resilience in human settlements. ISO/TR 22370 is supported by a number of other standards in the committee's portfolio, including one on community resilience and emergency management [9]. This document is primarily intended for use by organizations responsible for urban management. However, it is equally applicable to all types and sizes of organizations representing stakeholders, and especially to those organizations that have a role in urban planning, development and governance processes in urban areas around the world.

ISO 22301 consists of 9 sections, better known as clauses, which define the set requirements. Clauses 1 to 3 refer to the scope, normative references and terms and definitions used in the standard. Clause 4 defines five principles for building urban resilience, namely the dynamic nature of urban resilience, a systemic approach, promoting participation in planning and management, engaging multiple stakeholders and monitoring development goals. The fifth clause describes the characteristics that articulate urban resilience by describing what it entails (a persistent, adaptive and inclusive process) and how it can be achieved through integration, reflection and transformation.

The sixth clause refers to the framework for urban resilience. The proposed framework provides a transversal diagnosis and a path towards sustainable urban development based on resilience. To this end, multiple analytical lenses are adopted through which information covering the entire urban system is mapped, analyzed and interconnected, leading to a broader picture and thereby providing a basis for developing specific and prioritized actions to address risk. The framework consists of four overlapping phases: data, analysis, diagnosis and action. Figure 1 shows a schematic of the urban resilience framework.



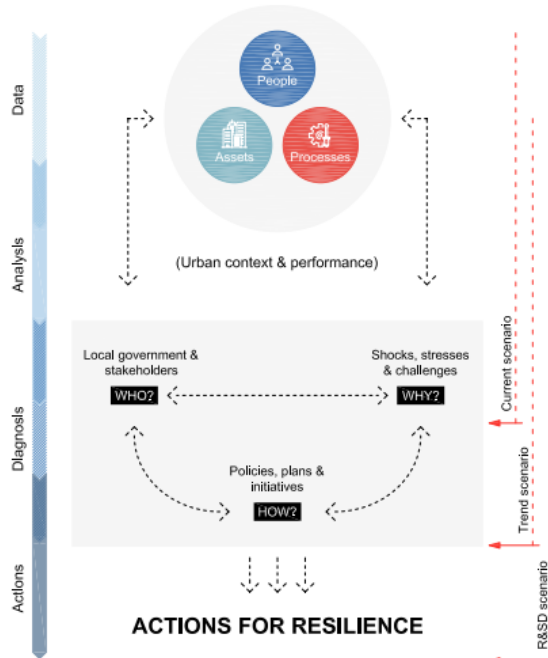


Figure 1. Urban resilience framework [11]

The action phase, through the Actions for Resilience (A4R) tool, is where a roadmap is created with local government and other relevant stakeholders, based on the diagnosis phase and potential development scenarios, to drive positive change through verifiable evidence of shocks, stresses and challenges.

Through the framework for urban resilience, three scenarios of an urban system can be built and used to improve its resilience. The first, i.e. the current scenario, is a generated analysis of the urban context and urban performance, through which the shocks, stresses and challenges they face are illustrated, the role of local government and stakeholders is mapped, and their interrelationships and impacts are assessed. The second, the trend scenario is built on the current scenario as it follows the trajectory of existing policies, plans and initiatives. It aims to assess whether there are ongoing actions that address the identified problems in the current scenario and reveal existing gaps. From this procedure, A4R recommendations can be formulated. The Resilient and Sustainable Development (R&SD) scenario is the last scenario built on the basis of the trend scenario and modified by the A4R recommendations. It gives a realistic idea of the possible transformation taking into account the priorities, management and capacities of the actors of implementation: local administration and other relevant actors.

Central to this framework is the urban system model. Urban system refers to the process of connecting, interacting, working and organizing components within an urban area regardless of its size, culture, location, economy and/or political environment. Urban areas can successfully respond to the impacts of economic, social, political or natural events when they are viewed as systems as a whole, connected both within and beyond their borders [10]. Recognizing this complexity and interconnectedness, the urban system model aims to systematically collect data, analyze information, and formulate diagnoses that identify strengths as well as

weaknesses when exposed to shocks, stresses, or challenges. The methodology for the operationalization of the urban system model is the assessment of the resilience of human settlements through the analysis of five dynamic and interdependent dimensions. The framework also applies these dimensions as filters to prioritize a number of shocks, stresses, and challenges, based on how significant they are relative to some or all of the system dimensions combined. The urban system model is shown in Figure 2.

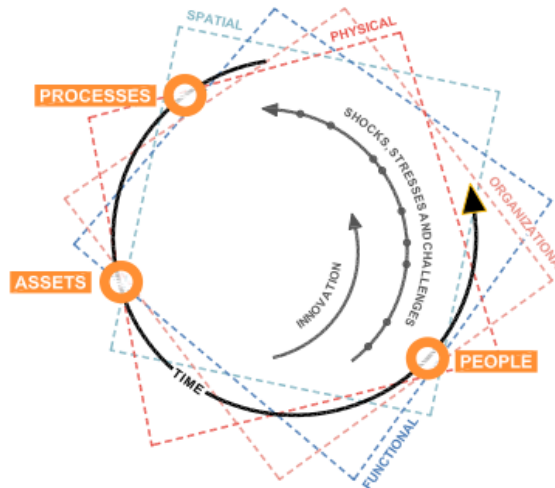


Figure 2. Urban system model [11]

Clause 7 defines Actions for Resilience (A4R), which are a key deliverable of the proposed framework. It is a policy-focused public strategic planning tool that combines risk reduction, vulnerability reduction, adaptation and capacity building activities with sustainable development to improve urban resilience. It represents the final processes for local government in the form of evidence-based actions (programs, projects and other initiatives) in a well-managed governance framework, which aims to strengthen political awareness, provide reasons for action and provide knowledge about what needs to be done. A4R aims to develop a shared vision among stakeholders for transformative change towards a more resilient and sustainable urban area aligned within international frameworks.

Clause 8 refers to the assessment of relevant international standards and frameworks. A preliminary assessment of current international standards relevant to resilience, including both published standards and those currently in development, reveals the approach to understanding resilience reflected within this proposed framework for urban resilience. This approach is expected to influence the development and revision of ISO/TC 292 documents in the future. Areas where this impact may be evident are disaster resilience, emphasis on the physical elements of resilience, the importance and benefits of including broad input from a range of countries, increased emphasis on resilience in an urban context, recognition of the important role of governance, an action-oriented approach and engagement interested parties.

Clause 9 refers to the conclusion and proposal for future work on standardization. Based on the assessment of relevant standards, it is recommended to develop a new comprehensive international standard for urban resilience that is coherent with

the already existing, and the overall international sustainable development agenda. The proposed framework would complement the already extensive documents produced by ISO/TC 292 and the aforementioned identified gaps. Furthermore, in its efforts to mainstream the UN SDGs, the program could provide resilience-relevant standards that contribute to the SDGs. In addition to contributing to the SDGs, a key outcome of the framework is the development of practical recommendations for local governments to address resilience building priorities in the short, medium and long term based on the multi-thematic and multi-dimensional recommended actions of the New Urban Agenda. Thus, the framework offers an opportunity to align international standards on resilience and the New Urban Agenda. Additional benefits of this approach, particularly context and performance assessments, are the identification of gaps in data availability and the generation of an inventory of existing or underdeveloped policies, plans and initiatives related to resilience at the local level.

#### 4. CONCLUSION

Disasters affect the economic and ecological position of the Republic of Serbia, reduce the development potential of the country, represent a risk to social stability and threaten EU investments. Compared to neighboring countries, the Republic of Serbia has developed and established a framework for the implementation of several strategies, laws and by-laws necessary to move from a reactive response in emergency situations to a proactive approach to disaster risk reduction in order to build the resilience of communities to current and future external shocks and stresses. Although some of these documents have not yet been adopted, it is crucial that this legislation be improved so that the roles and responsibilities of the various relevant actors are clearly defined and implemented. In the Republic of Serbia, there are 151 units of local self-government, but none of them apply the considered standard, and the key obstacles are lack of information, lack of technical capacity and training, difficulties in gathering technical-organizational teams, budget restrictions.

#### ACKNOWLEDGMENTS

This paper is a result of research funded by the Ministry of Education, Science and Technological Development of the Republic of Serbia pursuant to agreement No. 451-03-47/2023-01/200148.

#### REFERENCES

- [1] IPCC, **Managing the Risks of Extreme Events and Disasters to Advance Climate Change Adaptation**. A Special Report of Working Groups I and II of the Intergovernmental Panel on Climate Change C. B. Field et al., eds., Cambridge, UK and New York, NY, USA: Cambridge University Press, 2012.
- [2] Zoë, Scott & Marcela, Tarazona: **Study on Disaster Risk Reduction, Decentralization and Political Economy**, 2011.

- [3] IFRC, **Analysis of legislation related to disaster risk reduction in the Dominican Republic**, 2020.
- [4] United Nations General Assembly, **Sendai Framework for Disaster Risk Reduction 2015–2030**, A/RES/69/283, 2015.
- [5] Stojanović Ana, Vasović Dejan: **Analysis of the role of the local self-government units in disaster risk reduction planning**. 17th Conference with international participation risk and safety engineering, Novi Sad, 120-127, 2022.
- [6] Gencer, E.A. and UNISDR: **Local Government Powers for Disaster Risk Reduction: A Study on Local-Level Authority and Capacity for Resilience**. UNISDR, 2017.
- [7] Gencer, E.A., R. Folorunsho, M. Linkin, X. Wang, C.E. Natenzon, S. Wajih, N. Mani, et al.: **Disasters and Risk in Cities. In Climate Change and Cities: Second Assessment Report of the Urban Climate Change Research Network**. Cambridge University Press, 2018.
- [8] [https://international-partnerships.ec.europa.eu/policies/climate-environment-and-energy/water-energy-food-ecosystem-nexus\\_en#the-nexus-approach](https://international-partnerships.ec.europa.eu/policies/climate-environment-and-energy/water-energy-food-ecosystem-nexus_en#the-nexus-approach) (15.07.2023)
- [9] <https://www.iso.org/news/ref2745.html> (15.07.2023.)
- [10] UN Habitat. Trends in urban resilience, 2017. Available from: <https://unhabitat.org/books/trends-in-urban-resilience-2017> (15.07.2023.)
- [11] International Organization for Standardization ISO: **Security and resilience — Urban resilience — Framework and principles (ISO 22370:2020)**, Geneva, Switzerland, 2020.

# POTENTIALS OF EPHEMERAL ARCHITECTURE TO ENCOURAGE REUSE AND ADAPTATION OF ABANDONED INDUSTRIAL COMPLEXES

Dimitra Jezdimirović<sup>1</sup>

## Abstract

*Industrial complexes built during the 20th century on the territory of Serbia represent a monumental industrial heritage. Many examples of this architecture are abandoned now and are slowly falling into decay. Their reactivation, revitalization and conversion represent a very complex process. The potential of ephemeral architecture can be used for the beginning of approaching and introducing people into these complexes. Ephemeral architecture can contribute to the revitalization of space, and the creation of a new environment with a tendency to join industrial spaces with a cultural and educational function. The ephemeral new spaces establish an active connection with the visitors and the context in which they are, causing discrete impermanent changes in the space and presenting the industrial complex as a conceptual and free space. The goal of the research is to point out the problem of the deterioration of the industrial heritage and to look at some of the possible practical solutions through the incorporation of ephemeral volumes to promote these complexes, and their activation and later encourage them to be fully restored.*

**Key words:** *industrial buildings, industrial complex, ephemeral architecture, reuse, adaptation*

---

<sup>1</sup> Dimitra Jezdimirović, PhD student, Fakultet tehničkih nauka u Novom Sadu, dimitraj@z@gmail.com

## 1. INTRODUCTION

Industrialization represents the process of introduction and development of industrial production that led to a change in the economic structure. The concept of industry is related to production using machines. For the industry to function, in addition to workers and machines, it is necessary to provide driving power, raw materials, funds for production, traffic connections and a market where these products would be sold [1].

In Serbia, especially during the existence of Yugoslavia, branches of heavy and light industry were developed, in which companies were very successful and products were exported abroad [1]. According to data for the year 1965, there were a total of 2,466 industrial enterprises in Yugoslavia that employed more than 1.36 million workers, and 120 enterprises, called industrial giants, employing more than 2,000 workers, stand out. The largest number of industrial enterprises were located in the territory of the Federal Republic of Serbia, i.e. 909 enterprises with more than 483,000 workers. The next federal republic in terms of the number of industrial enterprises was Croatia with a total of 593 enterprises and about 230,000 workers [1]. Therefore, the faster development of industry on the territory of Serbia began after the Second World War [2]. At the beginning of the nineties of the 20th century, Serbia entered a transition period that was essentially accompanied by structural, financial and social changes. Also, this period follows deindustrialization, that is, the process of structural changes that lead to a decrease in the participation of industry and thus to a decrease in employment in industry [3]. As a result, many industrial complexes are abandoned today, but there are also examples of industrial complexes that are working or in the process of reactivation.

This paper deals with researching the potential of abandoned industrial spaces and looking at the potential offered by ephemeral architecture in the reactivation of industrial complexes. The main goal of the research is to point out the problem of the decline of industrial heritage and to give an insight into some of the possible practical solutions using the incorporation of ephemeral architectural forms.

The results of the research should suggest that in this way it is possible to promote these industrial complexes, their temporary reactivation and encouragement to restore these complexes completely.

## 2. METHODOLOGY

This research is divided into three parts. The first part of the research consists of a brief overview of the development of industrial complexes on the territory of Serbia and a concise analysis of industrial complexes, as well as their current status. In the second part, the concept of ephemeral architecture is defined, and the subject of analysis is the establishment of possible connections between industrial complexes that are not used in their entirety or are abandoned and ephemeral contemporary architecture. It will also look at the potential that this kind of intervention contains for starting the reuse of those abandoned factories, with special reference to the conversion of industrial spaces into cultural-artistic spaces. The third unit consists of the case study method, which includes three case studies of such realized ventures. The last part also contains the Discussion chapter, where it is considered whether

the interpolation of temporary architecture is an effective way to reawaken industrial sites and start their revitalization, as well as the conclusion of this research.

### **3. INDUSTRY IN THE TERRITORY OF THE REPUBLIC OF SERBIA**

At the beginning of the 20th century, the industry on the territory of Serbia was poorly developed and the agricultural population made up 88% of the total population. After 1906, i.e. after the Customs War, there was an increase in the number of industrial enterprises from 100 to 465, but they had small capacities, reduced production means and a small number of workers. The period after the First World War is a period of reconstruction of the country. The industry is still considered underdeveloped, while agriculture is significantly more prevalent. Significant growth and development of industry in our territory began after the Second World War when the socialist period of economic development began. This period is characterized by accelerated industrialization, deagrarianization, nationalization of the economy and urbanization [3]. The most important branches were the mechanical industry, the chemical industry, the electronic industry, the food industry, and the textile industry [2]. With the collapse of Yugoslavia, which was followed by hyperinflation and economic sanctions, Serbia enters a transition period and many industrial complexes are privatized or closed, leaving this numerous architecture abandoned and without a new function [3].

#### **3.1. A brief analysis of the concept of industrial complexes**

Each industrial plant, depending on the production, requires a certain concept of architectural space, and the organization of roads and green areas, so industrial complexes differ from each other. An industrial complex is defined as a set of several industrial facilities located on one plot of land and connected by a common technological process. The facilities are grouped into appropriate zones within the plot. The complex should contain production, storage, energy and other related facilities. The rest of the plot, which is undeveloped land, is used as a traffic area, a pedestrian area and a green area. The number of accesses to the complex varies concerning the nature of the industry, but a high level of control is characteristic of all. The positioning of objects on the plot is primarily determined by the technological program, but also by standard design restrictions such as the orientation of objects concerning the sides of the world, monitoring the permitted distance of objects, leaving space for possible extensions... The technological process flow can be linear or circular, while frequent spatial construction systems of industrial complexes are pavilion, block and mixed [4]. The treatment of the facades is in the style of the current aesthetics of the time.

#### **3.2. Abandoned industrial complexes and their perception today**

The construction industry heritage on the territory of Serbia today consists of a large number of industrial buildings, halls and complexes. However, formal industrial complexes generally do not have the status of cultural heritage, and due to a long-term lack of investment, this architecture is falling into disrepair. Abandoned industrial complexes today represent a memory of a period of different socio-political organization and industrialization of the cities where they are located [5]. They

currently do not perform their primary function but have a memorial function. Mostly in these areas, there is certain remaining furniture or machines in the halls, which creates additional opportunities for reconstructing work and has a certain ambient and narrative value. The very scene at that moment can be described as a melancholic and mysterious juxtaposition of ephemerality to be explored [6]. Industrial complexes have the potential to be revitalized. To restore these abandoned spaces, appropriate interventions are necessary due to the condition in which they are located and/or possible contamination that may affect the built and natural environment, as well as public health [7]. Adequate conversion is also necessary. In the following part, an overview of some criteria of importance for the selection of adequate abandoned industrial complexes as a place for the development of new functions within them is given:

- criterion of the legislative and institutional framework (analysis of the legislative framework and public-private partnership of interested parties for the reuse of industrial space, the amount of support and participation of citizens)
- criterion of city size (analyzing the number of inhabitants and visitors, the possibility of local employment, the cultural identity of the city)
- the criterion of location within the urban structure (analysis of the volume of industry within the currently developed part of the city, the proximity of related functions to the new function of the industrial complex, the connection with the rest of the city)
- the criterion of the architectural potential of the industrial complex and the suitability for the development of new contents (analysis of the relationship between the space of the industrial complex and the required space for the considered new function, the quality of the existing state and the size of the architectural intervention, architectural integrity)
- criterion of economic dependence (analysis of investment costs, potential rate of income and external financing of the revitalized industrial complex)

If the mentioned criteria and other parameters concerning each project separately concerning specific conditions and limitations are adequately analyzed, the degree of readiness of the industrial complex for the transition to the anticipated new function can be determined.

#### **4. THE EFFECT OF PLACING EPHEMERAL ARCHITECTURE IN AN ABANDONED INDUSTRIAL SPACE**

Ephemeral architecture is a broad term, but it can be narrowly defined as architecture that is temporary and mobile. However, there is no adopted exact definition of this type of architecture. Its potential lies in the fact that it can be used to establish new spaces within already existing spaces. It can be significant when adapting and refreshing an environment in a short period, realizing a certain concept. The method of ad hoc space transformation, where the existing space is not renovated for a new function, but the necessary furniture is adapted to the existing space by the new function, can be applied to abandoned industrial buildings [6]. Ephemeral volumes represent an experiment in which the intertwining of architecture, sculpture and art is visible. With its originality of form, this architecture



often refers to the imagination and the initiation of thinking on a certain topic. The time parameter is crucial for this type of architecture, as their end is predetermined. That is why we strive to achieve quality interaction with visitors during that period of their existence. The function assigned to some ephemeral architecture is often associated with certain symbolic meanings and metaphors [8]. Depending on the initial concept and the materials used, such ventures can be very convenient from an economic point of view. Using modern technology, it is possible to make this architecture using 3D printing, combining classic architectural elements with lighting, visual or sound installations and interweaving with virtual reality. Formed volumes can be walk-through or retaining type, as they allow visitors to sit, rest or spend time socializing.

#### **4.1. Possible approach(es)**

To completely restore the industrial complexes, a large amount of money is required, so their restoration is not promoted, and often there are no interested persons who would reactivate the original function of those factories. The application of ephemeral architecture could be the first step in the revitalization of these complexes and their repurposing for cultural and artistic purposes, educational, recreational or some other function. In this paper, the first mentioned purpose is particularly addressed, because these complexes have large spaces suitable for holding exhibitions, performances and manifestations. Because of their past, they contain a special conceptuality and authenticity, thus offering visitors, in addition to exploring the space, an exploration of its layers. Ephemeral architecture could direct and guide visitors with its form through the complex. In this way, some important segments of the factory would be pointed out to the visitors, but it would also leave the possibility for them to creatively explore and go through the technological processes of former production. At the same time, this strengthening of the research on the abandoned complex could be a way to stimulate the community's thinking about how that space could be used now. To encourage such a thing, it is necessary to establish a sustainable dialogue with the existing abandoned architecture when setting up the elements of the temporary new structure. It is desirable to further expand that dialogue to the communication of this newly created concept with the immediate environment, and then with the wider environment [6]. Due to its flexibility, it offers the possibility of experimentation with both form and materials and allows one to try several different ways of activating the observed industrial space. It can also be used to evoke that object or to create a new association of visitors to that complex through the events they experienced there [8].

#### **4.2. Conversion of industrial complexes into cultural-artistic spaces**

The potentials of abandoned industrial complexes are numerous. The repurposing of such spaces for cultural and artistic purposes is interesting because art in the absence of the classic exhibition white space gets a new reading and a new presentation of the work. By using parts of industrial complexes as an exhibition, a dynamic and dramatic component can be introduced into the perception of the exhibition. In this way, the symbolism of the abandoned industry becomes an integral part of the art installation. Also, by leaving certain units abandoned and subject to time decay, it is possible to record those places through photography or some other artistic technique, thus memorizing the moment of abandonment of those spaces

before the potential final revitalization and creating a chronology of the development of that complex. By using these spaces for artistic purposes by applying ephemeral architecture and giving freedom to visitors to express their views of the industrial space in which they are, it is possible to find a new function [6]. So it is important that these spaces at least at some point go through the process of acquiring a cultural and artistic function. Because the combination of ephemeral architecture, current art installations, seeing artists and visitors can lead to unexpected and innovative intervention solutions. The temporary structures contribute to connecting visitors with the space, and the methodology of their arrangement causes a certain sensibility and a new artistic or subjective perception of the industrial complex. By implementing this function in an abandoned industrial brownfield, there is a high potential to preserve the identity of the place, nurture the past and valorize their former value for the city in which they are located.

## 5. CASE STUDIES

In the following part, three selected examples of temporary repurposing of industrial complexes into exhibition and art spaces will be analyzed. The subjects of the case study method are: factory in Shenzhen, China; factory in Onda, Spain; factory in Brooklyn, USA. The selection of the analyzed projects was based on the following criteria:

- Selected case studies are located on different continents;
- Industrial complexes were abandoned, but they were temporarily activated as suitable spaces for exhibitions;
- The performed ephemeral interventions are unconventional, but the concepts of the selected examples differ from each other.

Basic data on the selected case studies are given in Table 1. Each example is analyzed on two levels: the idea and concept of incorporating ephemeral structures is analyzed and the spatial and functional composition of the project is analyzed. In the chapter Discussion through observing the connections of the previous conceptual breakdown of the selected examples, the following will be considered: the potential of ephemeral structures for the restoration of abandoned factories, the effect caused by the implementation of temporary forms in the conversion of industrial spaces into artistic spaces, what kind of dialogue is established with visitors with reference to the possibility of application to abandoned industrial complexes in Serbia.

*Table 1. Basic data on case studies*

	Case study I	Case study II	Case study III
Object type	Air conditioning factory	Ceramics factory	Marble factory
Location	Longgang District, Shenzhen, China	Onda, Spain	Brooklyn, New York City, United States
Area of the complex	5.000 m <sup>2</sup>	2901 m <sup>2</sup>	Unavailable data
Year of transformation	2019.	2015.	2015.

Project initiators	Bi-City Biennale of Urbanism/Architecture	City Council Onda	PEANA
Project designers	Atelier XI	El Fabricante de Esferas, Grupo Aranea and Cel Ras, Milena Villalba	Silvina Arismendi, Adrian S. Bara, Aldo Chaparro, Juan Fontanive i drugi
New function	Exhibition area	Exhibition area	Exhibition area
Project topic	Chronological development and stagnation of the Shenzhen industrial zone	The cultural identity of Onda and the significance of the factory „La Campaneta”	Dialogue on the topic of megalomania, existence and feelings
Performed interventions	A linear semi-transparent structure with occasional ramps passes through the halls of the factory and realizes a chronological narrative and a clear direction of visitors through the planned route	Linear metal frames in which photos of the current state of the factory are placed, connected with a rope to the construction of the hall where they symbolically join; additional furniture	Forms that are made from available materials in an abandoned factory can be used or can only be an aesthetic navigation to artworks
Used materials	Transparent membrane, steel, led light bulbs	Metal, wood, fabric, led light bulbs	Wood, marble, brick, metal, led light bulbs
Duration of the temporary installation	Three months	One month	One month

### 5.1. Case Study I – Factory in Shenzhen, China

The exhibition organized in a factory in Shenzhen represents an example where an abandoned industrial space is reactivated innovatively through the experimental implementation of a contemporary temporary form. The project was made in 2019 for The Bi-City Biennale of Urbanism/Architecture (UABB) by the Atelier XI bureau. Shenzhen is a city that is prone to gentrification. The reason is the increase in the price of industrial land, whereby producers leave factories and move to areas where the price of land is lower. Such a situation caused a large number of industrial complexes without function. Art institutions are one of the actors that promote the reuse of these factories and propose that they become cultural stations. This factory was chosen because of its location which was in line with the theme of the biennale, which is the urban history of the area where the factory is located. The implemented intervention (installation of an ephemeral structure) for the exhibition was done in such a way as to highlight the monumentality of the hall. The aspiration was that the space of the main hall symbolizes the history of the factory - its importance is shown by accentuating the spaciousness of the hall, the visible grid structural system and the corrosion that symbolizes ruin [9]. The area of 5,000 m<sup>2</sup> was reactivated in a month with a limited budget. The minimal intervention was done in the form of an ephemeral continuous volume. The inserted architecture is a bright two-layer

structure 250 m long, which with its whiteness creates a contrast with the existing walls of the hall and which moves along a broken path through the factory space. The factory space is divided into segments to create 20 exhibition spaces. To achieve additional dynamics, ramps were installed. The main material used in the creation of this ephemeral architecture is a transparent membrane that provides the possibility of installing single-sided, double-sided and double-curved light walls. The combination of an abandoned hall and a clean, illuminated structure creates an atmosphere that encourages visitors to perceive abandoned industrial complexes in a new way [10]. (Figure 1)



Figure 1. Ephemeral contemporary architecture within the premises of the factory (<https://www.frameweb.com/article/shows/how-designers-turned-an-abandoned-factory-in-shenzhen-into-an-exhibition-venue>)

## 5.2. Case Study II – Factory in Onda, Spain

The exhibition „Burnt Substance” was organized in the abandoned factory „La Campaneta” in Onda. This exhibition was first staged in this space and the theme of the exhibition is precisely the abandoned industrial heritage of that city and its current state. Farbika „La Campaneta” is the first ceramic factory in Onda, Spain. The town of Onda used to be a center for the production of ceramics. Due to the process of deindustrialization that occurred in the nineties of the XX century, many factories were closed. However, the industrial heritage still represents a very important segment of the city's identity. The author of the exhibition is Milena Villalba, an architect and photographer of architecture, industrial heritage and urban interventions. The author prepared the exhibition by visiting an abandoned ceramics factory and photographing its segments, thereby creating a document about the devastation of the „industrial landscape” [11]. The main organization of the space was done by the architectural bureaus El Fabricante de Esferas, Grupo Aranea and Cel Ras. The aspiration was to encourage socialization within the space of the abandoned factory to bring that space closer to the residents and other visitors. The project was initiated by the city council of Onda due to the fact that it is possible for this industrial complex to be demolished. It was decided to protect it as a cultural heritage of local importance, and the first measure in the revitalization of this complex was the implementation of temporary structures that will indicate the direction and theme of the renovation – a socio-cultural center and „park with industrial heritage” [12]. In the space of the main hall, metal frames were implemented where it is possible to place photos, which are connected with ropes to the structure of the hall, thus symbolically creating a connection between the exhibition and the abandoned space. A video projector was also installed. In addition to the exhibition, multi-day activities were organized, such as lectures and workshops for children [13]. For this reason, furniture made of metal and wood was added to certain rooms of the factory.

(Figure 2) The temporary activation of the factory in this way reconnected the factory with the local population, who expressed an interest in restoring the factory and actively using it for cultural purposes [13].



Figure 2. a) Appearance before reactivation b) exhibition space, c) space for workshops (<https://www.facebook.com/lacampanetaonda/>)

### 5.3. Case Study III – Factory in New York, USA

The abandoned marble factory „Puccio European Marble Works” in Brooklyn was used for the setting of the „Paradise Syndrome” exhibition. Brooklyn is one of the five boroughs of New York City and is the most populated area of the city. Previously, this city area was characterized by rapid industrialization, but due to changes in urban and social dynamics, a large number of industrial complexes are being abandoned. The exhibition deals with the theme of „excessive material wealth”. The curator is Ana Perez Escoto, and 12 artists worked on the project. The project was realized as part of a pop-up event from PEANA, a platform for contemporary Latin American and Spanish art. The name „Paradise Syndrome” represents the feelings of loss and discomfort that people experience after achieving their goals. Paradise has the symbolism of a state of purity, contentment and constant comfort. The state of confusion and disappointment after the realization of dreams and goals is exactly the opposite and it is shown through the selection of the space of the abandoned factory. The contrast between the dilapidated industrial architecture and the display of high material power is exactly what the visitors re-examine that phenomenon. The space of the abandoned factory is harmonized with the chaotically arranged exhibits of the exhibition and ephemeral structures made of restored wood, marble, brick and metal that were found in the factory space. Because they are built from available factory materials, these ephemeral structures appear as if they belonged there before and were not subsequently incorporated. They can be used for sitting, resting or just as an aesthetic navigation to the artworks that are arranged in smaller groups and make individual messages on the theme of the exhibition [14]. (Figure 3) Also, led lights and screens were used, as well as a video projector to complete the experience. The goal was to cause the visitor to recognize these contrasting feelings from those expected and to encourage thinking about the feeling of frustration over transience and the unattainable.



Figure 3. A segment of exhibition and ephemeral installations made from available materials in an abandoned factory (<https://www.yatzer.com/paradise-syndrome-peana/>)

## 6. DISCUSSION

**Potentials:** An analysis of three case studies located on different continents shows that each project has achieved success. Although all three cases are different in idea and design treatment, it can be said that in terms of concept, all three are unconventional and because of that, and because of their limited duration, they have interested the public to visit abandoned industrial complexes. The ephemeral exhibition, complete with installations within the industrial complex, achieves that the space of the former industry symbolizes a framed terrain for creative activities and engagement of people. The architectural intervention in this case is insignificant in relation to the possibilities of revitalization in the full sense, but its existence has the effect of continuing the further treatment and nurturing of this architecture. Depending on the applied strategy, different ideas can be implemented, and this approach offers numerous possibilities. The very aesthetics of industrial buildings, with their volume and complexity, additionally contribute to the realization of certain manifestations and events. All considered factories were visited during the duration of their exhibition space function. This means that ephemeral architecture can contribute to arousing public interest in abandoned industrial complexes and interest in investing in them with the aim of permanently converting them into artistic and cultural spaces due to the spatial potential it possesses. Therefore, the implementation of ephemeral architecture as a very free form has the potential to create benefits in the further development of abandoned industrial spaces.

**Effect and dialogue:** Through the spatial and functional analysis of the concepts of the selected case studies, it can be concluded that with adequate approaches, not necessarily financially expensive solutions, the space of an abandoned industry can be temporarily revitalized and adapted to the requirements of modern art spaces, primarily because of its surface, constructive structure, authentic atmosphere... By analyzing the concepts of the examples mentioned it is seen that the implementation of ephemeral structures gives the possibility of a new perception of old industrial architectural volumes, but also that these devastated industrial volumes can be used in the discussion on some other topics outside the industrial framework (case study III). Also, through the analyzed case studies, it can be seen that ephemeral structures can be placed as dominant guides for visitors through the complex (case study I), as unobtrusive structures that give primacy to the industrial space (case study II) or as structures that strive for subtle adaptation and coexistence with an industrial complex (case study III). Therefore, it is possible to realize the dialogue between the factory and ephemeral contemporary forms in different ways. The ways of communicating the now newly acquired cohesive environment with visitors also depend on that. Specific ephemeral revitalization aims to enhance the potential of abandoned spaces for the formation of new stages in their history of existence. The previous analysis of the industrial complex shows its architectural complexity, but also a clear boundary of the complex, therefore, looking in the reverse direction, industrial complexes contain excellent opportunities for establishing ephemeral activities because they form a clear framework of events - the space of industry.

**Possibility of application within our region:** Choosing a cultural function for abandoned industrial complexes should least threaten the existing identity of the place and the history of the place. On the other hand, it is necessary to develop the relationship of the revitalized industrial complex with the environment when it

assumes the function of culture. Conversion into cultural objects, if that function is adequately selected, can have a large and significant impact on the city. Nevertheless, the creation of interesting and adequate opportunities for the involvement of the local population, the economic profitability of the revitalization of these large complexes and the cost efficiency are challenges that should be continuously considered, because the social patterns of the local community can change and thus the long-term continuity of the plan cannot be guaranteed. which was originally set up. Certainly, this should not be a demoralizing attitude, because revitalization into cultural objects creates an associative and affirmative cultural landscape from an industrial brownfield, a degraded landscape, and thus very important for the urban development of the city. There is also a current opinion that we should leave these complexes to the course of time and not intervene on the objects that make them up, but look at their state of decay as it is (broken window panes, ruined doors, dusty objects, dilapidated walls). Certainly, passive observation of the environment thus formed can explore the unstructured past of the given building. However, industrial spaces make up large areas of an area, architecturally they offer great possibilities and therefore they should be activated. So that just viewing the object can be the first phase of getting to know these complexes, while in the following period, one can gradually intervene in a multi-level and multidisciplinary way. Ephemeral architecture gives the possibility to search for an ideal form, indicating that one solution of revitalization or conversion does not have to be imposed immediately.

## **7. CONCLUSION**

Objects in the process of devastation represent a unique form created by the architect and the nature of decay, which cannot always be predicted exactly. Temporary architectural volumes, i.e. ephemeral architecture can coexist with such changing architecture while bringing certain benefits in the reactivation of those abandoned objects. Gradual activation can be a significant procedure in the aspiration to re-use the premises of an abandoned industry, as it can even lead to a complete repurposing of a complex. By gradually rebuilding, although primarily due to a lack of funds, residents are reacquainting themselves with that structure within their city that was once a significant point. The aspiration of this kind of successive furnishing and revitalization of the complex is also to bring about a social awakening, the activation of the population to redecorate some space together. Therefore, ephemeral architecture does not harm but highlights the potential of industrial spaces through its implementation in the complex. Industrial architecture, which is certainly a special type of architectural heritage, should be preserved, but also reused. It is essential to work on its restoration with the obligatory preservation of memory and with the historical and social context. The data presented in the introduction about the number of industrial complexes on the territory of the Republic of Serbia indicate how much of this type of architecture we have and which, unfortunately, is largely abandoned today. These complexes can be transformed permanently, ephemerally, through the positioning of art installations and artistic practices carried out within them. Every way and attempt, whether clearly designed in advance or of an experimental nature, which leads to confronting the decay of this architecture is significant and correct. This paper only begins the development of the

theme of the revitalization of industrial complexes, because the area of research and finding a new purpose for this architecture is very layered, and therefore represents a wide area of work.

## REFERENCES

- [1] Planina Franc: **Jugoslavija, naš dom**. Vuk Karadžić, Beograd, 1968.
- [2] Stanišić Božidar, Bujošević Momčilo: **Geografija Jugoslavije sa osnovama socijalističkog samoupravljanja**. Zavod za udžbenike i nastavna sredstva, Beograd, 1980.
- [3] Vujadinović Snežana, Šabić Dejan: **Geografija 3**. Logos, Beograd, 2021.
- [4] [https://aggf.unibl.org/uploads/2015/03/02\\_T\\_Vujicic\\_Industrijski-kompleks\\_koncepcije-prostorne-organizacije\\_09\\_03\\_2015.pdf](https://aggf.unibl.org/uploads/2015/03/02_T_Vujicic_Industrijski-kompleks_koncepcije-prostorne-organizacije_09_03_2015.pdf) (9. 6. 2023)
- [5] Velbabović Tijana: **Očuvanje industrijskog nasleđa kroz turizam**. Zadužbina Andrejević, Beograd, 2016.
- [6] Zeković Miljana: **Efemerna arhitektura u funkciji formiranja graničnog prostora umetnosti**. Fakultet tehničkih nauka u Novom Sadu, Novi Sad, 2015.
- [7] CABERNET Network Report: **Sustainable Brownfield Regeneration**. University of Nottingham, Nottingham, 2006.
- [8] <https://www.ukessays.com/essays/cultural-studies/architecture-and-ephemeral-structures-cultural-studies-essay.php> (9. 6. 2023)
- [9] <https://www.frameweb.com/article/shows/how-designers-turned-an-abandoned-factory-in-shenzhen-into-an-exhibition-venue> (7. 8. 2023)
- [10] <https://architizer.com/projects/uabb-longgang-exhibition-hall/> (7. 8. 2023)
- [11] <https://thespaces.com/milena-villalba-photographs-ondas-abandoned-ceramics-factories/> (7. 8. 2023)
- [12] <http://www.elfabricantedeesferas.com/la-fabrica-la-campaneta-onda/> (8. 8. 2023)
- [13] <https://milnavillalba.com/substancia-cremada-campaneta-exhibition/> (8. 8. 2023)
- [14] <https://www.yatzer.com/paradise-syndrome-peana> (10. 8. 2023)



## DAMAGE FORMS OF STEEL CONSTRUCTIONS

Marko Milošević<sup>1</sup>, Dragoslav Stojić<sup>2</sup>, Srđan Živković<sup>3</sup>

### Abstract

*Steel damage can occur in many different forms. Some damage forms affect mechanical properties of steel (strength, ductility, tenacity, hardness, elasticity etc.) which can lead to damaging other constructive and non-constructive parts of the object, might jeopardize the function of entire construction and eventually they might lead to jeopardizing safety of the entire construction. This paper analyses processes and mechanisms of steel construction damage formation as well as their causes and effects, that are of great importance for steel constructions durability.*

**Key words:** *steel constructions, steel damage, types of steel damage.*

---

<sup>1</sup> Master in Civil Engineering, PhD student, Faculty of Civil Engineering and Architecture, University of Niš, marko.milosevic.mat@gmail.com, marko.milosevic@gaf.ni.ac.rs

<sup>2</sup> Professor, PhD, Faculty of Civil Engineering and Architecture, University of Niš, Dragoslav.Stojic.1@city.ac.uk, dragoslav.stojic@gaf.ni.ac.rs

<sup>3</sup> Associate Professor, PhD, Faculty of Civil Engineering and Architecture, University of Niš, srdjan.zivkovic@gaf.ni.ac.rs

## 1. INTRODUCTION

Damage within steel constructions can occur from various reasons [1], [2], [3], [4], [5], which are consequences of structural imperfections of used material, human mistakes [6] or incidents [7]. Most common causes of steel constructions damage are:

- mistakes in design, structural imperfections – inadequate design solutions that occur as a consequence of insufficient knowledge and professionalism of designer, contractor and investor, inadequate materials;

- lapses during building phase – non-compliance with standards and regulations or project itself, mistakes at the workshop, montage mistakes, inadequate anticorrosion protect, column inclination, eccentricity of joints;

- geometrical imperfections – inaccurate dimensions of cross-sections, curvature of elements;

- material imperfections – inaccurate chemical composition of steel and lower mechanical characteristics of determined, residual stress;

- irregular object examination or complete absence of examination – especially important at bridge constructions.

- Irregular object overview or complete absence of it – especially seen with bridge constructions. Practice in developed countries is having a specialized practice that performs regular reviews of objects and detects initial damage, which leads to timely rehabilitation work and causes decrease in expenses of maintenance as well as extension of construction lifetime;

- non maintenance and non-existence of funds for regular object maintenance expenses, which in some countries reaches up to 1,5-2% of investment object value;

- inadequate or damaged anticorrosion and fire protection;

- changes in intensity of permanent load or imposed load – additional permanent load, changes in object purpose, increase of traffic intensity, higher vehicle axle load; worn out roadway constructions at bridges;

- damages of reinforced concrete roadway slabs of coupled bridges;

- mechanical damages of object construction due to overrun of projected load, inadequate use, strikes, explosions, wind strikes, earthquakes.

Characteristic damage of steel constructions that are consequences of previously stated reasons are given within Figure 1 [8]:

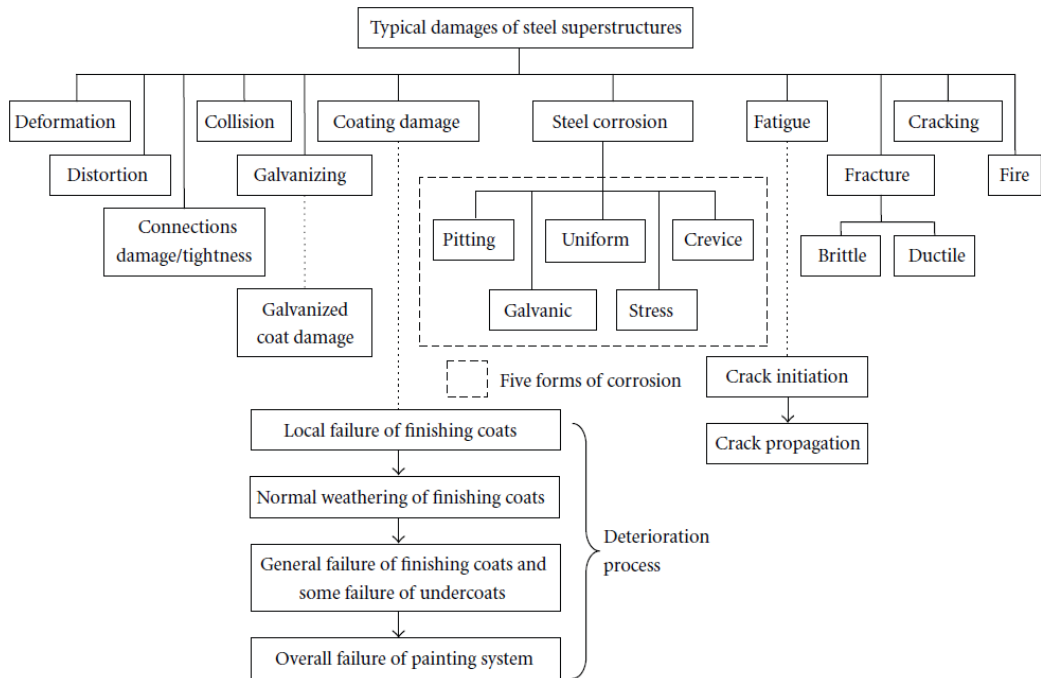


Figure 1. Characteristic damage of steel constructions [8]

## 2. TYPES OF DAMAGE OF STEEL CONSTRUCTIONS

In general, steel constructions demand higher attention during design phase as well as building phase, compared to constructions made of other materials. One of basic steel constructions damage partition is:

- mechanical damage;
- biological damage;
- chemical damage;
- corrosion;
- fire.

### 2.1. Mechanical damage of steel constructions

**Plastic deformation** (Figure 2) is a form of ductile break that occurs due to overrun of elasticity limit, where elements go through plastic (permanent) deformation before reaching ultimate tensile strength of steel [9]. This leads to visible deformations due to the ability of steel to stretch or bend. Before reaching cross-section exhaustion a large number of inner effects can be absorbed. Plastic deformation is often irregular in looks, with finished and/or thinned out parts of cross-section. The look of color or other types of spread at steel surface may indicate plastic deformation. Due to its fragile nature, cracks in color or spreads might occur in lines that are perpendicular to the local main load direction, especially if steel construction has a non-elastic deformation.



Figure 2 – Plastic fracture that indicates local thinning and irregular fracture surface [10]

**Brittle fracture** (Figure 3) might occur at stress levels that are below stretching limit or even below projected allowed stress levels [9]. In most cases it occurs with minimal or without any deformation, thus with minimal or no warning at all. Brittle fractures may lead to significant construction damage, object destruction and significant injuries. Brittle fractures usually have straight fracture surfaces without plastic deformation. Additionally, brittle fracture surfaces have a „V“ – shaped structure which can be used to determine the initial fracture spot and fracture direction. Brittle fracture occurs due to stress concentration at places such as screw holes or welding mistakes. They can occur at connection spots where the geometry of connection limits deformation. In general, thicker steel element (intersection parts, tin) are more likely to have brittle fractures compared to thin elements, due to the technology used to produce thick elements (e.g., difference in cooling spots at the surface and those within section). Brittle fracture occurrence is also affected by low temperatures and high stress load. The risk of brittle fracture due to low temperature can be lowered by choosing the appropriate type of steel.



Figure 3 – Brittle fracture [11]

**Buckling** is a form of construction damage that is primarily dependent on geometry of construction cross-sections. Reasons for this type of damage might be a large length of bending, lack of side adherence, shape of cross-section, high load intensity etc. Buckling is the only damage type that occurs at slim elements that are burdened by pressure. Buckling (Figure 4) occurs at long and slim elements such as

high columns, whilst local protrusion (Figure 5) occurs at slim plates with high width/thickness ratio.



Figure 4 – Buckling [12]



Figure 5 – Protrusion [13]

A large amount of construction elements is exposed to cyclic load of variable intensity, usually under maximum carrying capacity. The occurrence and spread of cracks in material due to cyclic load is called **fatigue**. Fatigue is most commonly seen at dynamically loaded constructions, such as towers, columns, bridges and similar, due to exposure to wind, vehicles or production process itself. Steel elements can collapse even under relatively low straining stress after a large number of load cycles. These cyclic loads cause microscopic plastic damage at places of stress concentration (screw holes, welding tips etc.). After a certain amount of cycles, a crack is formed that only spreads through steel structure in next cycle. Crack growth will continue to develop as long as effective cross-section is lowered to a level where element breaks (Figure 6). Failure due to fatigue is usually characterized by straight braking surface. Most fractures that form due to fatigue occur at welded connections. Steel, as a material, has a defined straining load fatigue level. Because of that, steel constructions fatigue can easily be eliminated by proper design and quality steel production.



Figure 6 – Failure due to fatigue [14]

Steel happens to slowly subject to non-elastic deformation under load at high temperature even if the stress is significantly under flow limit. This accumulation of damage is known as **crawling** and is in function of time, temperature and load.

Crawling is unusual in classic steel construction, unless in case of long-lasting fires. This damage is most likely to occur at elements that are exposed to constant temperature load, such as processing pipes, boiler pipes, turbine blades etc.

**Lamellar tearing** is usually seen at steel elements of higher thickness and is a consequence of residual small holes or non-metal particles that appear during rolling process or air bubbles formed during refinement process by blowing in converters [15]. Lamellar tearing phenomenon begins by crack creation inside the steel structure as a result of straining through thickness. Cracks can remain completely under steel surface, but can also occur on the surface in the form of fissure. This type of damage usually occurs at elements that are loaded perpendicular to rolling direction (Figures 7 and 8). There are ways to prevent lamellar tearing and include control of thick tins by ultrasound methods, proper detail design and a good choice of primary material. Otherwise, this kind of damage may cause a great object damage if not seen on time.

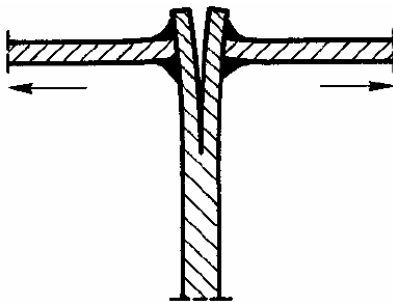


Figure 7 – Lamellar tearing

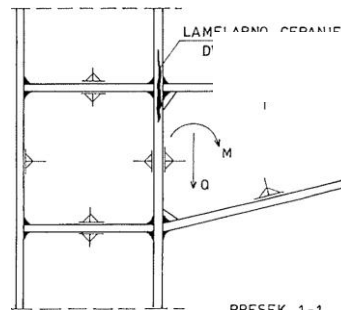


Figure 8 – Lamellar tearing of column-console connection [15]

## 2.2. Chemical damage

Chemical damage (Figure 9) occurs when salts on steel surfaces become exposed to atmospheric effects and cause damage to steel or when other substances such as oil, industrial chemicals, graffiti etc. affect steel surface.



Figure 9 – Chemical damage [16]

## 2.3. Biological damage

Biological damage forms due to human or animal remains presence, bacteria and herbal vegetation on steel surface or those that penetrate through steel. This type of damage is often seen at irregularly maintained bridges (Figure 10). The only way to prevent biological damage is regular maintenance and cleaning.



Figure 10 – Penetration of vegetation through the main beam of the bridge over Mlava river on the way to Rukumija monastery

## 2.4. Corrosion

The process of corrosion creation on steel that is not protected by anticorrosion film is very complex. Corrosion presents electrochemical process that is developing through phases (Figure 11). The first phase is happening on positively charged surface (anode) where iron ions travel to solution. Electrons are then released from anode and are moving through metal structure up to adjoining cathode zones (negatively charged zones) on the surface, where combined with oxygen and water they create hydroxyl ions.

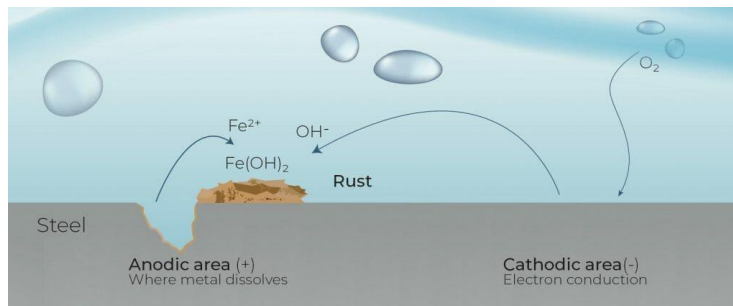


Figure 11 – Corrosion process [17]

Corrosion process is affected by variations in steel structures, such as natural presence of impurities due to large number of steel recycling cycles, uneven inside stress, exposure to acids, alkaline, chemicals, solvents etc.

There are many different types of corrosion and each has different structural effects.

**Rust** (Figures 12 and 13) is a type of corrosion of steel that reduces its mechanical characteristics. This type of corrosion has higher propagation when moist is present, especially if moist contains chlorides (salts) [18]. Rust is a state that is common in seaside, industrial and urban environment. When designing connections, it is very important to protect them from rust.



*Figure 12 – Rust on supports of the bridge over Mlava river on the way to Rukumija monastery*



*Figure 13 - Rust*

**General corrosion** (Figure 14) is usually seen at ordinary or low alloy steel that contains less than 13% of chrome due to neutral water and moist in air. Water layer allows electrolytic reactions to develop on the steel surface, which leads to progressive corrosion. Corrosion speed quickly increases in presence of other pollutants and higher moist levels.



*Figure 14 – General corrosion at the main beam of the bridge over Nišava river at the entrance at Nis Fortress*

**Galvanic corrosion** (Figures 15 and 16) occurs when different metals touch in the presence of moist which leads to corrosion of less noble metal.



*Figure 15 – Galvanic corrosion at parts of bridge over Mlava river in the way to Rukumija monastery*

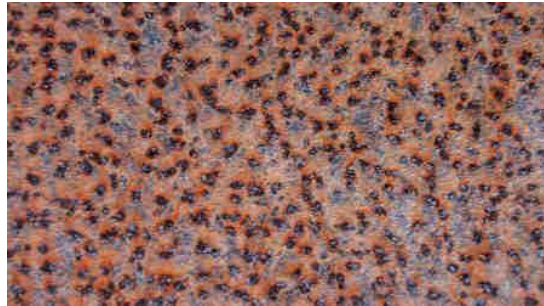


*Figure 16 – Galvanic corrosion*



The secondary effect of galvanic corrosion can lead to even higher damage. Hydrogen, as a by-product of galvanic corrosion might weaken spots of reinforcement and cause construction breakage.

**Pitting corrosion** (Figure 17) occurs due to anode (positively charged) zones that form corrosion pit. This corrosion is seen in soft steel when in touch with water or soil. Moist presence and exposure to alternately drying and moistening increases the risk of pitting corrosion occurrence. This type of corrosion can easily be prevented by properly performed details that allow quick draining and free air flow that helps dry the surface.



*Figure 171 – Pitting corrosion*

**Chemical corrosion** (Figure 18) is a process where metals dissolve in acids and caustic solutions as a consequence of metal tendency to react with oxygen and form different oxides. The lower nobility of metal is, the tendency to form oxides rises. One of acids that cause this type of corrosion is sulfuric acid that forms as a result of emission of sulphur dioxide from fossil fuels and is more common in urban and industrial environments. Chemical corrosion can be caused by nitrogen oxides, chlorine, hydrogen chloride, formic acid, acetic acid and other acids that can be found nearby industrial plants. Chloride and sodium chloride are common causative agents of corrosion at seaside.



*Figure 2 – Chemical corrosion*

When it comes to **crevice corrosion** (Figure 19) the amount of oxygen in water trapped in crevice is lower than in water that is exposed to air. That causes the crevice to become anode and the corrosion begins to form inside the crevice.



Figure 19 – Crevice corrosion

When two different metals (i.e., iron and aluminium) connect, electricity runs through them and creates **bimetal corrosion** (Figure 20). This phenomenon is used to classify metals depending on their electric potential and this classification is called galvanic series.



Figure 3 – Bimetal corrosion

**Stress corrosion** (Figures 21 and 22) occurs due to the effect of straining stress in material that is placed in corrosive environment. In zones of stress concentration anode zones are formed and those are places where corrosion process begins. This type of corrosion is not common with black metals, whilst stainless steel is susceptible to it.



Figure 21 – Stress corrosion at transverse beams of the bridge over Nisava river in front of Nis Fortress



Figure 22 – Stress corrosion

**Bacterial corrosion** (Figure 23) is a result of microbiological activity and occurs at construction parts that are in touch with soil or water. This type of corrosion is most commonly seen in pipelines, buried structures and coastal objects.



*Figure 23 – Bacterial corrosion*

As the process of corrosion evolves, the „corrosion products“ develop a tendency to accumulate in certain metal parts. These corrosion products have different element structure than the original metal. The new layers of corrosion on the surface lead to changes in anode and cathode areas which leads to primarily non-corrosive metal areas becoming susceptible to corrosion. The result is accelerated corrosion of steel surface.

## 2.5. Fire

Fire on steel construction or in nearby area causes a very uneven distribution of temperature which causes decrease in mechanical steel characteristics such as stretching limit, straining firmness, module of elasticity. This changes cause changes in function (Figure 24) or collapse of some construction parts, sometimes of the entire construction. Steel temperature in the moment of fracture is usually considered to be critical temperature and depends on type, size, configuration, orientation and straining of steel element.



*Figure 4 – The look of the connection of steel elements after fire*

## 3. CONCLUSION

Steel damage can occur in many forms. Some types of damage affect mechanical features of steel (firmness, ductility, tenacity, hardness, elasticity etc.), which may lead to damage of other constructive and non-constructive parts of the object, and even to damage of safety of entire construction. By knowing how steel construction damage may form, what causes them and what are their effects, as well

as knowing how to prevent them is of high significance for durability of steel constructions.

## REFERENCES

- [1] Yang Na, Fan Bai: Damage analysis and evaluation of light steel structures exposed to wind hazards. *Applied Sciences*, 7(3), 239, 2017.
- [2] Xibing Hu, Rui Chen, Yuxuan Xiang, Yafang Chen, Qingshan Li: **Mechanical Behavior of Damaged H-Section Steel Structure**. *Advances in Civil Engineering*, 1-15, 2021.
- [3] Pržulj Milenko: Mostovi: koncipiranje, projektovanje, konstruisanje, pouzdanost, građenje, gospodarenje, obnova. *Udruženje "Izgradnja"*, 2014.
- [4] Guang-chong Qin, Tao Lan, Qing Qin, Shan-hua Xu, Zong-xing Zhang: **Degradation Model and Evaluation Criteria for the Seismic Behavior of Corrosion H-section Steel Column**. *KSCE Journal of Civil Engineering*, 23, 3694-3705, 2019.
- [5] Meng Wang, Yongjiju Shi, Weiguo Yang, Yuangling Wang: **Influence of damage and degradation index on steel frame under severe earthquakes**, *Advances in Structural Engineering*, 18.12, 2035-2046, 2015.
- [6] Aplsten Göran: **Uncertainties and Human Errors in the Design and Execution of Steel Structures**. *IABSE Symposium Report*, Vol. 107, No. 1, International Association for Bridge and Structural Engineering, 2017.
- [7] Wardenier Joost: **Hollow section joints**. *Delft Univesity Press*, Delft, 1982.
- [8] Kevin K. L. So, Moe M.S. Cheung, Eric X.Q. Zhang: **Life-Cycle Management Strategy on Steel Girders in Bridges**. *Advances in Civil Engineering*, 2012
- [9] Andre Pineau, Amine A. Benzerga, Thomas Pardoen: **Failure of metals I: Brittle and ductile fracture**. *Acta Materialia*, 107, 424-483, 2016.
- [10] <https://upload.wikimedia.org/wikipedia/commons/1/1b/DuctileFailure.jpg>
- [11] <https://civildigital.com/wp-content/uploads/2014/06/0512-is-2-300x225.jpg>
- [12] Po-Chien Hsiao, Kazuhiro Hayashi, Hiroyuki Inamasu, Yun-Biao Luo, Masayoshi Nakashima: **Development and Testing of Naturally Buckling Steel Braces**, *Journal of Structural Engineering*, 142(1), 04015077, 2016.
- [13] Pedro C.G. da S. Vellasco, Roger Hobbs: **Local Web Buckling in Tapered Composite Beams: A Parametric Study**, *Journal of the Brazilian Society of Mechanical Sciences*, 23, 411-425, 2001.
- [14] [https://en.wikipedia.org/wiki/Fatigue\\_%28material%29#/media/File:Pedalarm\\_Bruch.jpg](https://en.wikipedia.org/wiki/Fatigue_%28material%29#/media/File:Pedalarm_Bruch.jpg)
- [15] Debeljković Miroslav: **Čelične konstrukcije u industrijskim objektima**. *Građevinska knjiga*, Beograd, 1995.
- [16] Franck Schoefs, Maria Joao Correia, Hugo Perneta, Maria Manuela Salta, Laurent Gaillet, Hugo Patricio: **Duratinet: Maintenance and Repair of Transport Infrastructure – Technical Guide: Steel Structures – Part III, Deterioration**. *Laboratório Nacional de Engenharia Civil*, Divisão de Divulgação Científica e Técnica, Lisboa, Portugal, 2012.
- [17] <https://cathwell.com/app/uploads/2019/09/Corrosion-cell-1-e1568876193829-1024x422.jpg>
- [18] Di Sarno Luigi, Armin Majidian, George Karagiannakis: The effect of atmospheric corrosion on steel structures: A state-of-the-art and case-study. *Building*, 11.12, 571, 2021.

# THE USE OF “GEOTEXTILES” FOR THE PROTECTION OF ARCHAEOLOGICAL SITES WITH MOSAICS

Elena Vasić Petrović<sup>1</sup>

## Abstract

*The use of „geotextiles“ and other similar construction materials became a crucial part of typical procedures for the protection of archaeological sites during the last decades. Following the growing worldwide trend conservators and archaeologist introduced this material to Serbian sites, too. This paper aims to showcase different types of application of the same material, because of its numerous advantages, like low cost and easy installation, but also a lack of understanding of the construction materials' properties and very often inappropriate use. The focus is given to the archaeological sites with mosaic pavements, since these fragile structures may suffer a great degradation considering the facts from the previous statements. Also good practice will be noted, since there are lots of ways to test and monitor the applied systems and to better understand how to improve the efficiency of the used materials. This kind of study may lead to change in technical specifications, and some of them might be modified in the future to better serve the protection of archaeological sites and other heritage structures in general.*

**Key words:** *Geotextile, Archeological Sites, Protection, Reburial, Mosaics*

---

<sup>1</sup> architect - conservator, adviser, Institute for Cultural heritage Conservation Niš, elena@studioagnis.com

## 1. INTRODUCTION

The three main areas where soil reinforcement can be applied are: slopes, foundations and retaining walls. Introduction of “geomaterials” with higher strength and higher tensile strength, brought a new solution to usual geotechnical problems.

In Serbia the start of intense use of “geosynthetics” and “geotextiles” in road construction dates back to the 70’s of the XX century. The main advantages of these materials are low cost, easy and clean technology of installation [1].

During the last four decades the materials commonly called „geotextiles” were very intensively used in the construction industry. They can have constructive and bearing functions and this means that the field of their application is very wide. By applying geomaterials in the construction industry, the amount of building materials and the cost of construction are usually significantly reduced. Therefore, their use has unique advantages over other soil reinforcement techniques, for technical, economic and sustainable reasons.

Probably because of the fact that they are normally applied to the road construction, which is almost mandatory preceded by the archaeological excavations, especially in our region, it also became a favorite material to be applied to different protective measures and procedures taken by the archaeologists and conservators.

The need for a material that can be used in several different ways (as separation layer, marker and instant covering solution, or for example as a slope-stabilizing feature), but at the same time is easily accessible and cost affordable, led into wide use of „geotextiles“ in the field of preventive conservation and maintenance of the structures that are endangered by a great variety of natural and human factors. This is also the reason why almost any archaeological excavation plan must contain “geotextile” as one of basic materials.

In order to better understand the properties of “geomaterials” according to their original purpose, what are the benefits, but also how the protected structures could be damaged by their misuse, some of the examples from the specific area of mosaic pavement conservation in the Mediterranean area, including Serbian sites, will be presented<sup>2</sup>.

“Geotextiles” are used in almost all archaeological campaigns and in a way, this became a sort of “solution” for all archaeological and conservation problems, but here the main focus will be at archaeological sites with mosaics.

The area which dominantly abounds in preserved mosaic floors and pavements, especially from the antiquity and Byzantine period is positioned around the Mediterranean Sea [2]. This is why, in general, the main research in this field is focused on the archaeological sites based there. Most of the Serbian sites are not that highly valued as those from Northern Africa or Middle East but certainly they belong to that same corpus in the historical sense and in some cases have high artistic and unique cultural value (for example Justiniana Prima - Lebane and Felix Romuliana - Zaječar).

---

<sup>2</sup> Author is a scholar of the Getty Conservation Institute from Los Angeles, USA and has been certified from several courses on the Management of Archaeological Sites with Mosaics, that took place at UNESCO World Heritage Sites all over Mediterranean (Nea Paphos-Cyprus, Herculaneum-Italy, Umm-Al Rasas and Petra-Jordan)

## 2. GEOTEXTILES” AND THE REBURIAL PROCEDURE

The term “geotextile” comes from the Greek word for Earth (Gea) and it refers to any textile material used in the earth or soil for technical purposes. The Textile Institute from USA defined geotextiles, in “Textile Terms and Definitions” as “any permeable textile material used for filtration, drainage, separation, reinforcement, and stabilization purposes as an integral part of civil engineering structures of earth, rock or other construction materials” and another definition says that “geotextiles are permeable textiles used in conjunction with soils or rock as an integral part of a man-made project” [3].



Figure 1. Geotextile in road construction, source: <https://mc-plus.hr/novosti/blog/gradevinski-materijal-geotekstil-43/> (8.6.2023)

Considering the structures obtained by manufacturing, geotextiles can be produced as various fabrics: woven, non-woven and knitted or needle punched. Aside from these types of “geotextiles”, in practice there are other materials (“geosynthetics”) considered as geotextile-related products, such as geomesh, geonets, geocells, geogrids and geocomposites, which are used individually or in combination with others in order to enhance their action by working in synergy or to obtain a multitask layer and can be produced of natural fibers, too [4].



Figure 2. Geosynthetics - “geonet” in road construction, source: <https://en.milford.dk/products/geonet> (8.6.2023)

They are made of synthetic polymers (such as PP, PE, PET and PVC) and belong to a group of high-performance materials that have grown during the last decades into needful auxiliaries when it comes to infrastructure, soil, construction, agriculture, and environmental applications [5]. They can be a simple solution for numerous specific problems that engineers are facing in the fields of civil engineering, ecology, spatial planning, but also archaeology and conservation, which has not been adequately processed so far, mainly because of the lack of engineers included in the planning and problem solving in this area of expertise

*Table 1. Geosynthetics according to the IGS (International Geosynthetics Society), source: <https://www.geosyntheticssociety.org/>, 8.6.2023.*

<b>GSY</b>	<b>GEOSYNTHETICS</b>
GT	geotextile
GG	geogrid
BT	biotextile
GA	geomat
GL	geocell
GN	geonet
GM	geomembrane

When it comes to archaeological sites the “geotextiles” are usually used in the process called “reburial”. This is a methodology based on the thesis that any archaeological site or any kind of structure unearthed during the archaeological excavations, if not conserved and presented, should be covered again. In this way we will provide the finding with the approximately same micro climate as it was before the excavations.

This is where the “geotextiles” started playing a very significant role, when choosing the layers for the reburial procedure and they became the unavoidable part of the systems designed for different reburial purposes.

The other important application is “slope stabilization” due to the fact that archaeological excavations produce very often problems with slides.

It is important to note that most of the archaeological sites in Serbia are not properly reburied or treated in any way once the excavations are done. Usually they are left covered only with plastic sheets or some kind of “geotextile” or in most cases completely open.

There are no official regulations or instructions on the procedures that should immediately follow the excavations and the term “reburial” is not officially recognized in our law or in archaeological and conservation practice.

By this we are leaving the unearthed structures to decay and finally to a complete degradation and disappearance. This is completely unacceptable, but yet it is our reality and it needs to be changed.



### 3. EXAMPLES OF APPLICATION AND COMMON MISTAKES

When it comes to archaeological sites with mosaics, the pavements themselves are usually considered to be their most valuable part. Most of the visitors are interested in these assets and everything else is subordinated to it.

Management of the sites is quite challenging and complex.

Mosaic “carpets” are originally made to serve in the closed rooms or at least covered porches. In reality they are found at the sites where not much of the architectural structures are preserved, so once they are revealed in the archaeological campaign they stay outside in open air.

It is believed that 80% of the damage on the mosaics comes from the excavations. Leaving the fragile structures to open air conditions means additional stress and further degradation.

The most diverse heavy weather and environmental conditions strike those features during the change of seasons or during the day. For example, once the mosaics are unearthed the temperature fluctuations on their surface become more strong, the water stays on the surface and can frost in the winter, it also rises and brings salts to the surface, etc.



*Figure 3. Mosaic in open air at Nea Paphos - Cyprus, photo: Vasić P. Elena, 2014.*

This is why there is a need for some kind of protection, but at the same time mosaics need to be visible for the visitors.

Organizing seasonal reburial and designing the right solutions is a constant struggle for the site managers. But if there are no protective shelters built, this is the only possible way to protect these valuable features of the site.

Sometimes the “geotextiles” are used like the only cover directly on the mosaic surface. In other cases they are covered with a thin layer of sand.

These types of protective measures are acceptable only for short term reburials or during the conservation treatments for the purpose of dust protection.

Otherwise the “geotextiles” should not be used in this way, directly on the surface, because they can stick to the mosaic and by removing them, we could cause serious damage.

Also “geotextiles” are not designed to stay in the open air, so for example they are not considered to be “UV stable” and should not be left uncovered.

Beside “geotextiles” many other materials (“geomash”, “geonet”, etc.) are used within the reburial systems and again in a great variety of combinations, for multiple purposes.



*Figure 4. Geotextile applied directly to the mosaic surface at the site of Porto Torres in Sardinia - Italy, photo: Vasić P. Elena, 2014.*

The one and only truth is that you never know how and when your “short-term” intervention could become a long-term problem and this is why we need to learn more about the materials we use and to work on establishing measures that will prevent damage to the assets that we are trying to protect.



*Figure 5. Plastic net applied directly to the mosaic surface at the site of Jerash - Jordan, photo: Vasić P. Elena, 2022.*

Vegetation is also a great problem for the mosaics *in-situ* and in open-air conditions. It is interesting how the used material can influence the growth of the vegetation, but also can stimulate the microorganism development.

If used as a part of the reburial including thicker layers of sand, gravel or soil, the “geomaterials” should also be very carefully selected. They should be water and vapor permeable, because undisturbed water transmission is crucial for the system to be sustainable.

Just like in the original application for the road construction, here we also have to use and combine different materials to get the best results.

#### 4. RESEARCH RESULTS AND SPECIFIC PROPOSALS

The results of the research conducted in the “laboratory” and *in-situ* will be presented further and they refer to the properties of the materials that we can buy as “geomaterials” and use at the archaeological sites with mosaics, for the reburial systems.

The properties of a “geotextile” depend on its end use with different functions. Properties required for the following various functions: separation – combined properties of reinforcement and filtration, reinforcement – strength, extension under load, degradation with time, filtration – permeability, porosity of fabric etc, drainage – transmissivity.

Proper selection of “geotextiles” for a particular application is only possible if there exists a foolproof testing and evaluation method. This is why the systems used for reburial should be checked on the regular basis depending on the expected duration of the protective measures. The monitoring procedure is supposed to be recorded and notes should be made for future reference.

Site managers are in charge of this procedures where they are available, but in some cases the systems, as mentioned before, that were used decades ago have no monitoring and we have no clue how to act even if we have an opportunity to change something.

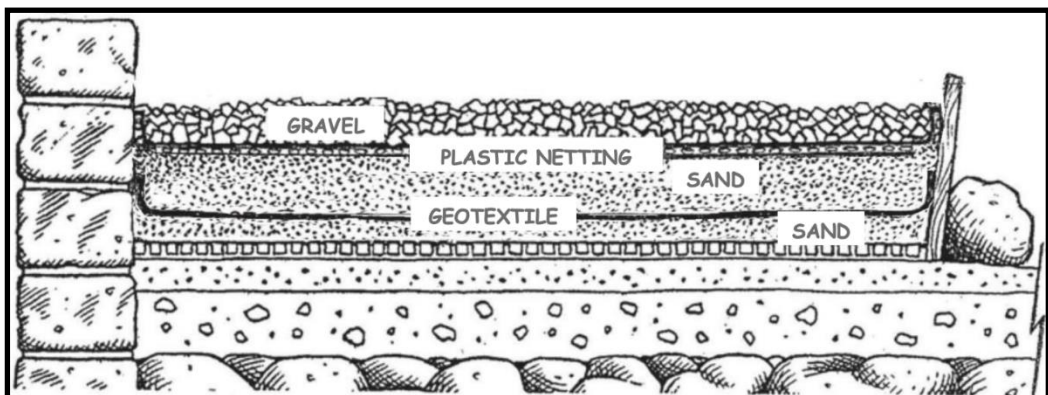


Figure 6. Example of reburial system, source:

[https://www.getty.edu/conservation/publications\\_resources/teaching/pdf/mosaics\\_conservation/mosaics\\_reburial.pdf](https://www.getty.edu/conservation/publications_resources/teaching/pdf/mosaics_conservation/mosaics_reburial.pdf) , 8.6.2023.

When “geotextile” is placed between two layers, one coarse grained and other fine grained, the fabric should allow free passage of water from one layer to

another. The purpose of geotextile with reference filtration and drainage is simply to retain soil while allowing the passage of water. The geotextile rapidly channels water from soil to various outlets and thereby provides higher shear strength of soil and hence stability. High permeability property of fabric is very useful for the purpose. Good permeability of the fabric is essential for filtration and drainage [6].

Within the reburial systems “geotextiles” are generally most often used as separation layers. This is where we need to be sure that we chose a proper type of “geotextile” for the exact problem.

*Table 2. Advantages and disadvantages of “geosynthetics” used as separation layers in reburial systems, source:*

*[https://www.getty.edu/conservation/publications\\_resources/teaching/pdf/mosaics\\_conservation/mosaics\\_reburial.pdf](https://www.getty.edu/conservation/publications_resources/teaching/pdf/mosaics_conservation/mosaics_reburial.pdf) , 8.6.2023.*

<b>Type</b>	<b>Advantages</b>	<b>Disadvantages</b>
Woven plastic sheeting	-Effective separation between fill materials -Easily available and inexpensive	-Reduces liquid-water/water-vapor transport -Fairly ineffective barrier to vegetation penetration and animal activity -Promotes growth of roots underneath
Non-woven geotextiles and other synthetic fabrics	-Permits water-vapor transport -Partially effective against vegetation penetration and animal activity -Effective separation between all types of fill materials	-Reduces liquid-water transport -Promotes growth of roots underneath -Hard to obtain and expensive

Sometimes unusual problems occur, due to the total lack of interest or poor practice that should be avoided in the future [7].

During the past decade we have been struggling with different administrative and jurisdiction confusion which led to a total abundance of one of the most important mosaic floors in Serbia, preceded by the period of lack of reburial maintenance and management in general. It is the Basilica with the Transept mosaic, that is in focus, at the archaeological site of Justiniana Prima (Caričin grad) near Lebane.

It is completely not understandable that this mosaic has been left without any kind of care for 20 years now. After the thin sand layer was removed for the last time back in the 90’s of the XX century for photo-shooting, the sand was spreaded again in even thinner layers (approx. 2-3 cm) and the site was left.

Since that nobody was willing to take responsibility for any kind of maintenance or salvage procedure that will at least prevent further degradation and completely unacceptable inaction.

The proposal made by the author in cooperation with international experts is some kind of re-reburial, since there is no possibility to remove the former layer of sand, because it is transformed into a mix of soil and vegetation, complemented with the detached *tesserae* of the mosaic floor.

In order to take proper action and not just wait, the system was designed as follows: vegetation treatment with spraying and no removal, thin layer of clean sand, needle-punched geotextile, clean soil (total reburial depth: approx. 50 cm). This means also that the surrounding architectural structures - walls need previous stabilization and conservation. It should be considered as a long term system (over 5 years), since there is no consensus on the future maintenance and monitoring. The reburial process should be documented properly.



Figure 7. Archaeological site of Justiniana Prima, photo: Aleksandar Ćirić, 2017.

## 5. CONCLUSION

Technical textile products are now essential for every sector of engineering as well as our practical life.

A “geotextile” is a permeable textile material that is used with foundation, soil, rock, earth, etc to increase stability and decrease wind and water erosion. Its main functions are: separation (confinement), reinforcement, protection, filtration and drainage. Geotextile can be successfully used in new projects and also in repair works. They are also capable of providing instance solutions under distress situations [6].

Geotextiles have already been extensively used in various fields of constructions and civil engineering all over the world. This is why they also came into wide use in archeological and conservation projects, but without serious research and elaboration of the results and case-studies.

Therefore further research and development efforts are needed to improve the production, product quality and scope of applications, especially in the fields mentioned above. The range of functions of “geotextiles” can be enhanced and the product can be made with more potential and versatility of applications.

## 6. REFERENCES

- [1] Stanković Mirko: **Geosintetici u infrastrukturnim projektima**, source: [https://www.researchgate.net/profile/Mirko-Stankovic/publication/340580887\\_GEOSINTETICI\\_U\\_INFRASTRUKTURNIM\\_PROJEKTIMA/links/5e91ffda4585150839d46a4c/GEOSINTETICI-U-INFRASTRUKTURNIM-PROJEKTIMA.pdf](https://www.researchgate.net/profile/Mirko-Stankovic/publication/340580887_GEOSINTETICI_U_INFRASTRUKTURNIM_PROJEKTIMA/links/5e91ffda4585150839d46a4c/GEOSINTETICI-U-INFRASTRUKTURNIM-PROJEKTIMA.pdf) (8.6.2023)
- [2] Roby Thomas: The reburial of mosaics-an overview of materials and practice. Conservation and management of archaeological sites. Vol.6, 229-236, 2004.
- [3] Subrata Chandra Das, Debasree Paul, Mir Muhammad Fahad, Tarikul Islam, Md. Eanamul Haque Nizam: **Geotextiles A Potential Technical Textile Product**. Journal of Scientific and Engineering Research. Vol. 4(10), 337-350, 2017.
- [4] [GEOTEXTILE: IT'S APPLICATION TO CIVIL ENGINEERING – OVERVIEW](#) (9.6.2023)
- [5] Fulga Tanasă, Marionara Nechifor, Maurusa-Elena Ignat and Carmen-Alice Teacă: **Geotextiles—A Versatile Tool for Environmental Sensitive Applications in Geotechnical Engineering**. Textiles. Vol. 2, 189–208, 2022.
- [6] Vasić Petrović Elena, Cvetković Ivana: **Problematika konzervacije kamena na arheološkim nalazištima**. Zbornik radova "Kamen i opeka"-Gradjevinski materijali i konzervatorsko-restauratorski postupci, DKS, Beograd 2015.
- [7] Devanand Uttam: **GEO TEXTILES - FUNCTIONS, MATERIAL AND ITS APPLICATION**. *International Journal of Advanced Research in IT and Engineering*. Vol.1, No. 4, 2012.

# EVALUATION OF BRIDGE TRAFFIC LOAD MODEL USING B-WIM MEASUREMENTS IN SERBIA

Goran Milutinovic<sup>1</sup>, Rade Hajdin<sup>2</sup>

## Abstract

*The concept of Bridge Weigh-in-Motion (B-WIM) system means that bridge is applied as a weighing scale to determine the weights of the vehicles on the bridge, during measurements of regular traffic. Such B-WIM measurements were performed on 17 locations throughout Serbia, in duration of 14 days each, in 2020, and on one location since December 2020. These measurements include the information about axle weights and axle spacings for each vehicle that has passed the B-WIM station, as well as the recorded time and speed of the passage. These measurements represent a solid basis for the probabilistic study currently performed to obtain an appropriate traffic load model for existing bridges in Serbia, since entire traffic, on all lanes on the bridge, can continuously be reconstructed from B-WIM measurements. Structural analysis of a representative set of bridges, loaded by all vehicles detected by B-WIM had been performed. These load effects have been compared with equivalent load effects produced by the design value of Eurocode Load Model 1, in order to obtain the  $\alpha$  coefficients, i.e. the multiplier for the constituent loadings of the LM1 to be defined in the National Annex, based on local traffic volume and composition. Future statistical study of these  $\alpha$  coefficients will enable the estimation of the  $\alpha$  coefficients to be used in Serbia for assessment of existing bridges. The limitation of this analysis is given by the short time period covered by B-WIM measurements, so additional traffic simulations or scaling have to be done in the future. The use of adequate load model for existing bridges would have significant economic impact for bridge owners ("JP Putevi Srbije"), since the lower  $\alpha$  coefficients on the sound scientific basis would safely keep many bridges in service, without the need for their upgrading or demolishing.*

**Key words:** *traffic load model, bridge weigh-in-motion, existing bridges, probabilistic study*

---

<sup>1</sup> PhD student, University of Belgrade Faculty of Civil Engineering, gormilutin@gmail.com

<sup>2</sup> Professor, University of Belgrade Faculty of Civil Engineering, rade.hajdin@grf.bg.ac.rs

## 1. INTRODUCTION

The concept of Bridge Weigh-in-Motion (B-WIM) system means that bridge is applied as a weighing scale to determine the gross weights, axle loads and axle spacings of the vehicles on the bridge within regular traffic. Such B-WIM measurements were performed on 17 locations throughout Serbia (shown in Table 1), in duration of 14 days each, in 2020, and on one location since December 2020. These measurements include the times and speed of the vehicle passages. These measurements represent a solid basis for the probabilistic study currently performed to obtain an appropriate traffic load model for existing bridges in Serbia, since entire traffic, on all lanes on the bridge, can continuously be reconstructed from B-WIM measurements. Structural analysis of a representative set of bridges loaded by all vehicles detected by B-WIM had been performed. These load effects have been compared with equivalent load effects produced by the design value of Eurocode Load Model 1 (the main bridge traffic load model by the Eurocode, shown in Figure 1), in order to obtain the  $\alpha$  coefficients, i.e. the multiplier for the constituent loadings of the LM1 defined in the National Annex, based on local traffic volume and composition. Future statistical study of these  $\alpha$  coefficients will enable the estimation of the  $\alpha$  coefficients to be used in Serbia for assessment of existing bridges. The limitation of this analysis is given by the short time period covered by B-WIM measurements, so additional traffic simulations or scaling have to be done in the future. The use of adequate load model for existing bridges would have significant economic impact for bridge owners (“JP Putevi Srbije”), since the lower  $\alpha$  coefficients on the sound scientific basis would safely keep many bridges in service, without the need for their upgrading or demolishing. This will also reduce the environmental impact of road infrastructure.

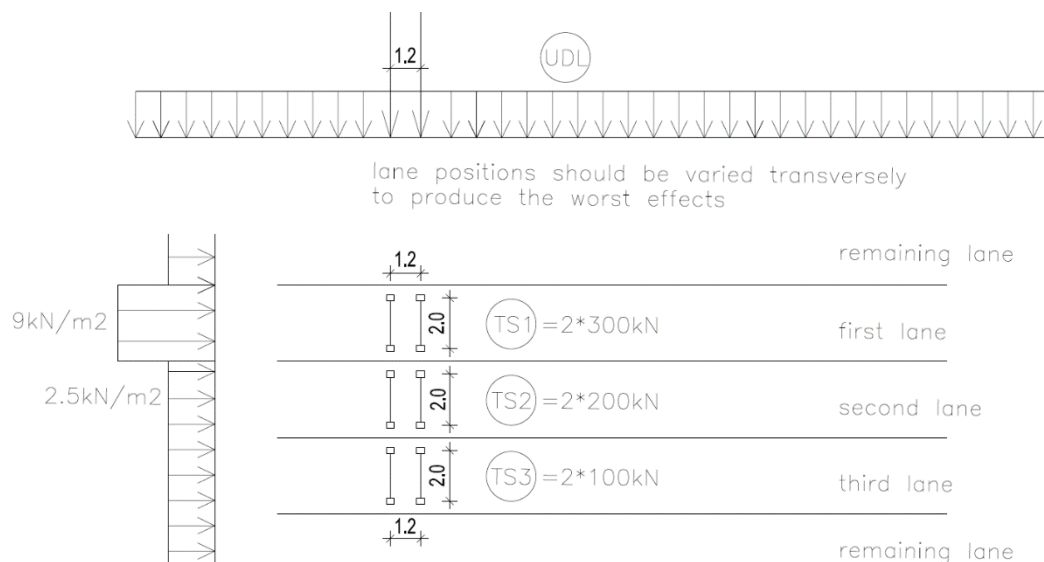


Figure 1. Eurocode Load Model 1



## 2. B-WIM MEASUREMENTS IN SERBIA BY JP PUTEVI SRBIJE

The concept of the Bridge Weigh-in-Motion (B-WIM) system means that bridge is a weighing scale to determine the weights of the vehicles on the bridge. One such commercially available system, SiWIM from Slovenian company Cestel, is in use in several countries, including Serbia, where it is purchased by JP Putevi Srbije. It is a portable B-WIM system, installed by mounting on the bridge superstructure, without any interfering or closing the traffic during installation. It is continuously determining and recording the exact location and speed of all vehicles present on the bridge, as well as its axle weights and axle spacings. The sensors are attached to the lower side of the bridge superstructure either by means of anchors in holes or, when drilling holes is not allowed, by attaching the strain transducers to steel mounting plates that are glued on the surface of the superstructure (see Figure for installation of the system in Serbia).



Figure 2. Installation of the SiWIM system in Serbia

The lane where the vehicle has passed the B-WIM station is recorded. Only vehicle with weights larger than 34kN (mass larger than 3.5 tons) are recorded in the database. The time stamp precision of the measurements was 1 millisecond. The overview of all 17 locations is shown in

. There are 290,388 recorded vehicles in the B-WIM database.

	Road	Road type	Section	Bridge ID	ADTT		Road	Road type	Section	Bridge ID	ADTT
1	IB 12	highway	Zrenjanin–Novi Sad	Culvert	1007	10	IB 24	highway	Batočina - Kragujevac	1668	676
2	IB 21	highway	Novi Sad–Irig–Ruma	3191	1270	11	IB 24	highway	Batočina - Kragujevac	1627	695
3	IA 1	freeway	Belgrade – Novi Sad	0495	2357	12	IB 36	highway	Paraćin - Boljevac	Culvert	1099
4	IA 1	freeway	Belgrade – Novi Sad	0496	2705	13	IA 2	freeway	Obrenovac - Ub	699	814
5	IB 13	highway	Zrenjanin – Kovilovo	3161	938	14	IA 2	freeway	Obrenovac - Ub	700	1010
6	IB 26	highway	Šabac – Loznica	1760	1045	15	IB 23	highway	Požega - Cacak	2000	1519
7	IB 21	highway	Ruma – Šabac	Culvert	1937	16	IA 4	freeway	Bela Palanka - Piroć	599	785
8	IB 22	highway	Meljak – Lazarevac	1049	1250	17	IA 4	freeway	Bela Palanka - Piroć	600	688
9	IB 22	highway	Ušće – Raška	4903	947						

Table 5. Overview of the B-WIM stations

From gross-vehicle-weight (GVW) histograms from four locations in Figure , it can

	Road	Road type	Section	Bridge ID	ADTT		Road	Road type	Section	Bridge ID	ADTT
1	IB 12	highway	Zrenjanin–Novi Sad	Culvert	1007	10	IB 24	highway	Batočina - Kragujevac	1668	676
2	IB 21	highway	Novi Sad–Irig–Ruma	3191	1270	11	IB 24	highway	Batočina - Kragujevac	1627	695
3	IA 1	freeway	Belgrade – Novi Sad	0495	2357	12	IB 36	highway	Paraćin - Boljevac	Culvert	1099
4	IA 1	freeway	Belgrade – Novi Sad	0496	2705	13	IA 2	freeway	Obrenovac - Ub	699	814
5	IB 13	highway	Zrenjanin – Kobilovo	3161	938	14	IA 2	freeway	Obrenovac - Ub	700	1010
6	IB 26	highway	Šabac – Loznica	1760	1045	15	IB 23	highway	Požega - Cacak	2000	1519
7	IB 21	highway	Ruma – Šabac	Culvert	1937	16	IA 4	freeway	Bela Palanka - Piroć	599	785
8	IB 22	highway	Meljak – Lazarevac	1049	1250	17	IA 4	freeway	Bela Palanka - Piroć	600	688
9	IB 22	highway	Ušće – Raška	4903	947						

be concluded that there are three modes (most frequent values): light trucks just above 34kN (3.5 tons), around 150kN, and around 400kN. A sharp drop in number of vehicles can be seen after 400kN, corresponding to usual legal limit for regular 5-axle vehicles. It is expected that there will be some vehicles with GVW larger than 432kN (44 tons) with special permits issued by authorities.

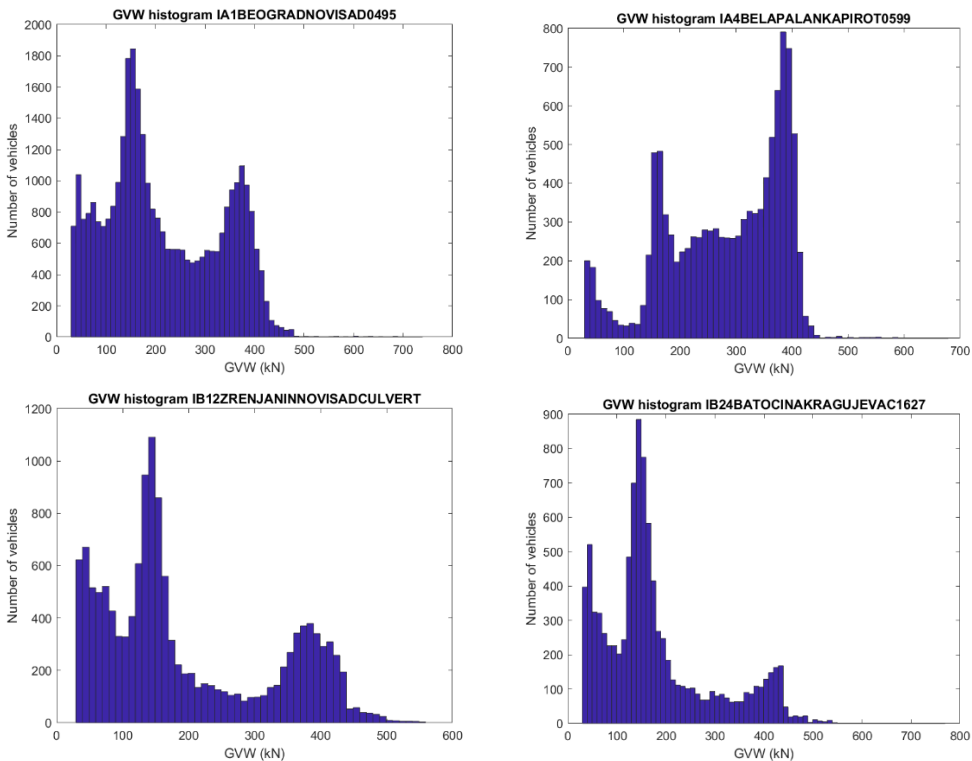


Figure 3. GVW histograms

### 3. METHODOLOGY

An outline of the performed structural calculation is presented in this chapter (similar analysis has been already performed in [1]). Direct structural analysis of the recorded vehicles from a WIM database, on a set of bridges, was done based on the following principles and assumptions:

A generic, but realistic bridge cross section was constructed consisting of precast prestressed concrete beams, acting compositely with cast-in-place concrete deck, shown in Figure ; load effects in the first interior beam were considered in the analysis (carriageway widths is 7.5m); location of the first lane for Eurocode Load Model 1 corresponds to the assumed location of the slow lane from WIM measurements;

Significant points on moment and shear diagrams are the following (L being the span length):

- 0.5L for simple-span moment (midspan),
- 0.4L, and 1.0L for continuous-span moments (midspan and support),
- shear near each support;

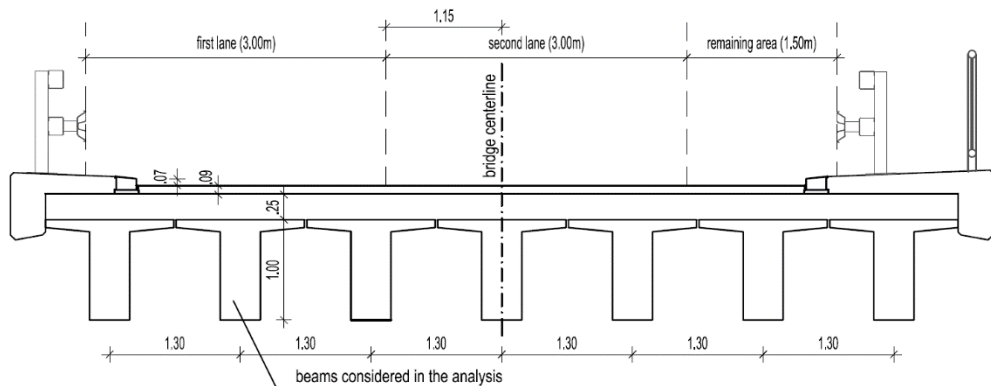


Figure 4. Generic bridge for transverse load distribution analysis

'Loading event' is made for each vehicle from WIM database heavier than 400kN, taking into account simultaneous presence of other vehicle on the bridge.

The threshold of 400kN for the 'main vehicle' (the main part of the 'loading event') is used for two reasons: (a) to reduce the computing time, and (b) it is not probable that the vehicle with the GVW smaller than 400kN would produce load effects comparable with the LM1 whose only one axle of the first-lane TS weighs 300kN. All weights mentioned include the dynamic amplification factor;

The total bridge length up to 200m is the length used in calibration of the LM1;

Transverse load distribution was calculated assuming that the bridge cross section deflects and rotates as a rigid cross-section (a procedure similar to the conventional approximation for loads on piles); this is a method for transverse load distribution in bridge structures referenced, for example, in [2] and used for similar purpose in [3];

After transverse load distribution described above, the resulted beam line loading (for first interior beam) was then analyzed on the beam model, calculating first the influence lines and then moment and shear envelope for each considered loading, using an automated process;

The set of bridges is specified to cover the entire suite of bridges possible to encounter in practice. The set consists of simple-span beam and two-span continuous beam with total bridge length from 5m to up to 200m with the span length increment of 5m for 50m span and less, 10m increment for span lengths from 50m to 100m, and 20m increment for span lengths from 100 to 200m – this will create a set of 35 different bridges (span arrangements):

One span (5, 10, 15, ..., 45, 50, 60, ..., 90, 100, 120, ... 180, 200m; 20 bridge total);

Two equal continuous spans (2x5, 2x10, 2x15, ..., 2x45, 2x50, 2x60, ..., 2x90, 2x100m =15 bridges total).

The  $\alpha$  coefficient calculated herein and shown below is the unique  $\alpha_Q$  coefficient, for all loaded lanes and for both loadings, TS and UDL;

The vehicles weights from WIM measurements with included dynamic amplification factor (DAF) should be compared to LM1, since the LM1 inherently includes the DAF. Since static weights are provided in the B-WIM records, the 10% increase is added as an 'average' DAF. Due to large variability of the parameters influencing the DAF, the simple approach was used, which is the same one adopted during the original LM1 calibration – to multiply the static weights by the factor 1.1 in order to obtain the total loads including the DAF. Namely, during original creation of the LM1, it was assumed that WIM data, used as the starting point for the study, included the average DAF equal to 10%, so the WIM weights were divided by 10% [4]. This 10% value is also in agreement (and even slightly conservative) with experiments done in [5] and [6], as DAF decreases with the GVW increase.

By following the above explained principles and assumptions, the actual calculation is planned to be done according to the following five steps:

Each vehicle from the WIM database with dynamic GVW larger than 400kN is stored and will be called the 'main vehicle'. For each 'main vehicle', all vehicles 100m behind it and 100m in front of it are detected from the WIM data and they will be called 'accompanying vehicles'. Vehicles in the same and in adjacent lane, as of the 'main vehicle', are considered. Vehicle with any static GVW larger than 34kN (3.5 tons) can be an 'accompanying vehicle';

'Main vehicle' and all its 'accompanying vehicles' on the computed distances create one 'loading event'. Distance between first axle of the main vehicle and first axle of an accompanying vehicle is easily computed, since the speed and passage time of each vehicle is stored in a B-WIM database. Distance to the 'accompanying vehicles' in front of the "main vehicle" is computed by the speed of the 'accompanying vehicles' multiplied with the time difference between the passage of two vehicles over the WIM location. Distance to the 'accompanying vehicles' behind the "main vehicle" is computed by the speed of the 'main vehicle' multiplied with the time difference between the passage of two vehicles over the WIM location. The distance between the first axle of the first vehicle and the first axle of the last vehicle in the 'loading event' will be 200m or smaller.

For each 'loading event' from the WIM database, moment and shear envelope are computed for the first interior beam for each bridge (i.e. the bridge span configuration) from the described set of bridges;

On each of these bridges, moment and shear on significant locations for one 'loading event' (for first interior beam) are divided with the corresponding moment and shear induced by the design value of Eurocode LM1 (the characteristic value

times the partial load factor of 1.35) to obtain a ratio; maximum ratio on the bridge will be recorded for that bridge and for that 'loading event';

For each 'loading event', there are 35 ratios (since there are 35 bridges in the set of bridges, if entire span range between 5m and 200m is considered). Average ratio of all 35 ratios for one 'main vehicle' becomes the new element in the sample for the future statistical study – the new random variable.

#### 4. RESULTS

As a part of the automated process, 64,254 'loading events' from B-WIM measurements in Serbia were analyzed on each bridge from the set of 35 bridges previously described. There were so many 'main vehicles' in the database with the GVW larger than 400kN, with the DAF included. First, using the so called rigid method, mentioned previously, transverse load distribution was calculated for each "loading event", and beam line loading was created for first interior beam, for the generic bridge cross section, shown in Figure . Then, influence lines, and moment and shear envelopes were computed for each of these 64,254 'loading events', for each bridge from the set of bridges, and were compared directly with the LM1, as described earlier. The sample moment envelope diagrams (for the interior beam) for a 'loading event' from WIM database (DAF included) and for the LM1 on one bridge (two span of 30m) from the set of bridges are shown together in Figure .

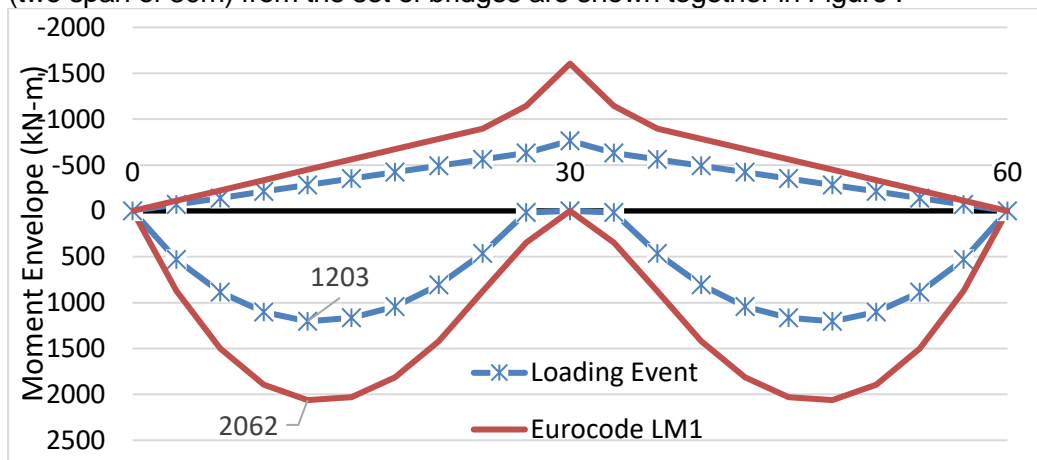


Figure 5. Sample moment envelope comparison for sample 'loading event' from B-WIM records vs LM1

Ratios between the load effects of the sample „loading event' and the LM1 on this bridge was computed for each significant point previously described, and the maximum ratio for this bridge is recorded as  $1203/2062=0.58$  (positive moment at 0.4L at interior beam in Figure ). The analyses were repeated for the same „loading event' for each bridge from the described set of bridges, and each time, the maximum ratio for that bridge is recorded – there were 35  $\alpha$  coefficients for this „loading event' (if the entire span range, from 5m to 200m is considered). The average ratio of these 35 values is taken as the characteristic of the vehicle (i.e. 'main vehicle') that is further processed as the alpha coefficient for that vehicle. The maximum alpha coefficient from any vehicle on each location during two-week measurements were stored and presented. In Figure and Figure , bar charts and

histogram, respectively, are shown for two-week extreme value measurement for every of 17 B-WIM locations, but considering only span range from 5m to 80m (instead entire span range from 5m to 200m), which represent most of the bridge inventory in the country.

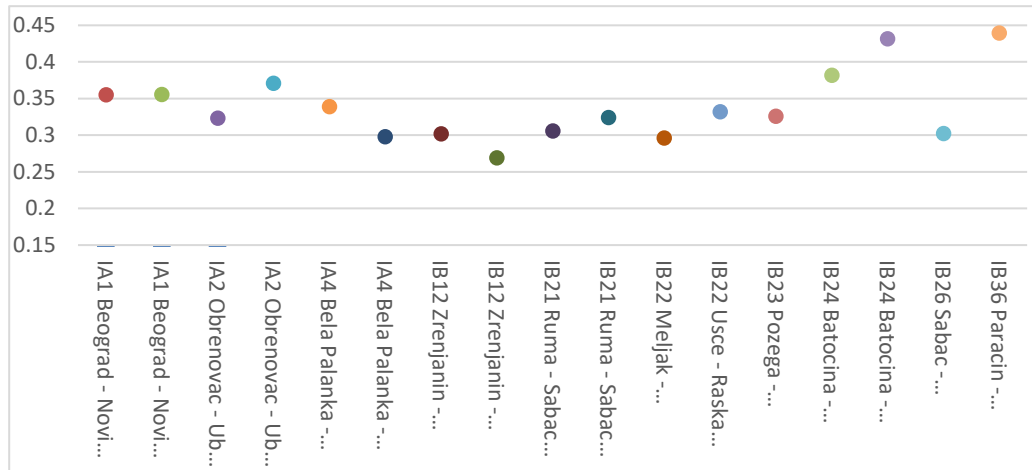


Figure 6. - Bar charts with alpha coefficients for two-week extremes (span range 5m to 80m)

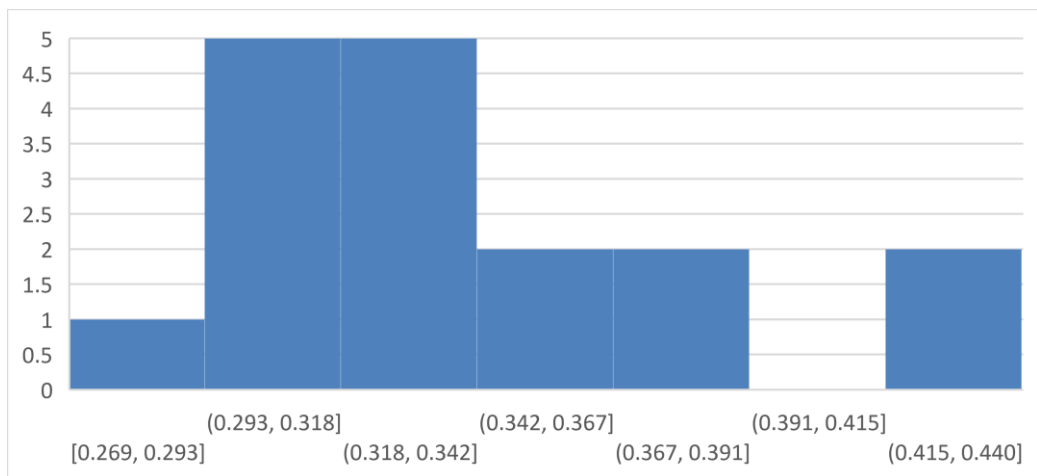


Figure 7.- Histogram of alpha coefficients for two-week extremes (span range from 5m to 80m)

The ‘main vehicle’ whose ‘loading event’ created largest  $\alpha$  coefficient, was on the B-WIM station on the road IB36, between Paracin and Boljevac. It was a 22.6-m-long nine-axle truck with the static GVW of 1267kN, together with eight-axle ‘accompanying vehicle’ in the same lane (the static GVW equal to 856kN) that has passed the measuring location 4.728 seconds after the ‘main vehicle’. This ‘main vehicle’ passed over the B-WIM measuring device on November 10th 2020. in 05:17:45.738 with the speed of 45 km/h. The maximum  $\alpha$  coefficient for this ‘loading event’ was 0.514 on one of the bridges from the set of bridges, and the average  $\alpha$  coefficient for all bridges (the value that goes to the extreme value sample) was 0.440, if span range from 5m to 80m is considered. Therefore, this ‘main vehicle’, together with its ‘accompanying vehicle’, created extreme value loading event for

this B-WIM location (equal to the average of 0.440 and shown in Figure ) for the extreme value sample. It is important to note that these ratios –  $\alpha$  coefficients – are based on the total load effect, including DAF.

## 5. DISCUSSION

By analyzing the bar charts in Figure , and histograms in Figure , it can be concluded that two-week maximums are mostly in 0.25 to 0.40 range. This fact confirmed the necessity and usefulness of the probabilistic study currently performed which has the goal to propose the alpha coefficients to be used for assessment of existing bridges, much lower than the full design loads for new bridges. The use of adequate load model for existing bridges would have significant economic impact for bridge owners (“JP Putevi Srbije”), since the lower  $\alpha$  coefficients on the sound scientific basis would safely keep many bridges in service, without the need for their upgrading or demolishing. The limitation of this analysis is given by the short time period covered by B-WIM measurements, so additional traffic simulations or scaling have to be done in the future.

## 6. CONCLUSION

Results shown in this paper represents a valuable basis for future probabilistic study and extrapolation to the 1000-year return period defined for characteristic value of the main Eurocode bridge traffic load model (LM1). Statistical study of these  $\alpha$  coefficients will enable the estimation of the alpha coefficients to be used in Serbia for assessment of existing bridges. The limitation of this analysis is given by the short time period covered by B-WIM measurements, so additional traffic simulations or scaling have to be done in the future. The use of adequate load model for existing bridges would have significant financial impact for bridge owners (“JP Putevi Srbije”), since the lower  $\alpha$  coefficients on the sound scientific basis would safely keep many bridges in service, without the need for their upgrading or demolishing.

## REFERENCES

- [1] G. Milutinovic, C. Kusiak, M. Bowman, and A. Prakash, “**New Approach for Screening Overweight Vehicles: Allowable Ranges of Axle Configurations,**” *Transportation Research Record*, vol. 2642, no. 1, pp. 118–126, Jan. 2017, doi: 10.3141/2642-13.
- [2] “LRFD Bridge Design Specification, 7th Edition.” AASHTO, 2014.
- [3] M. Sjaarda, T. Meystre, A. Nussbaumer, and M. Hirt, “**A systematic approach to estimating traffic load effects on bridges using weigh-in-motion data,**” *Stahlbau, Ernst & Sohn*, 2020.
- [4] J.-A. Calgaro, M. Tschumi, and H. Gulvanessian, *Designer’s guide to Eurocode 1: Actions on bridges*. in Designers’ guides to the eurocodes. London: Telford, 2010.
- [5] J. Kalin, A. Žnidarič, A. Anžlin, and M. Kreslin, “**Measurements of bridge dynamic amplification factor using bridge weigh-in-motion data,**” *Structure and Infrastructure Engineering*, vol. 18, no. 8, pp. 1164–1176, Aug. 2022, doi: 10.1080/15732479.2021.1887291.

- [6] H. Ludescher and E. Brühwiler, “**Dynamic Amplification of Traffic Loads on Road Bridges,**” *Structural Engineering International*, vol. 19, no. 2, pp. 190–197, May 2009, doi: 10.2749/101686609788220231.



# ANALYSIS OF THE CONCEPT OF BUILDING INTEGRATED PHOTOVOLTAICS WITH INTEGRATION TO THE ARCHITECTURAL DESIGN

Viktorija Mangaroska<sup>1</sup>, Kosta Mangaroski<sup>2</sup>

## Abstract

*Solar energy was recognized as one of the most important renewable energy technologies in many countries in the recent years. The renewable technologies achieved an important awareness among architectural engineers, who see the concept of integration of photovoltaic system as a new opportunity for integration to the architectural design. Analysis of urban disposition of the solar radiation in the cities is becoming an important factor in conceptualizing the intersecting systems as a basis for architectural study in the organization and orientation of buildings for optimizing the solar potential. In the beginning of the development of the photovoltaic systems, as a solar power generating renewable technologies, they were analyzed only by electrical energy engineers, which created only standard products with limited design possibilities in terms of patterns, dimensions, texture and colors. Integrated approach with architectural engineers is important sustainable factor for the optimization and sustainability of the architectural design.*

*The recent development of the solar renewable technologies and the PV systems, created a new possibilities for them to be reviewed as architectural elements in the architectural design process by many important international architectural studios. Architects must think of new concepts of integration of the photovoltaic systems as architectural elements by creating pixel photovoltaic module and patterns in monocrystalline cells, as well as using different visible materials, textures and color in the thin film modules of the photovoltaic cells in the composition of the architectural design. This scientific paper will explore the architectural possibilities in the architectural design of building integrated photovoltaics in terms of the functional, constructive and aesthetics formal aspects. Building integrated photovoltaics modules should respond to the technical aspects of the energy production, as well as, be integrated as architectural elements according to the function and the building envelope: adaptive facade, double facade, PV shading cladding systems in the architectural buildings.*

**Key words:** *Architectural Design, Building Integrated Photovoltaics, Solar Renewable Technology*

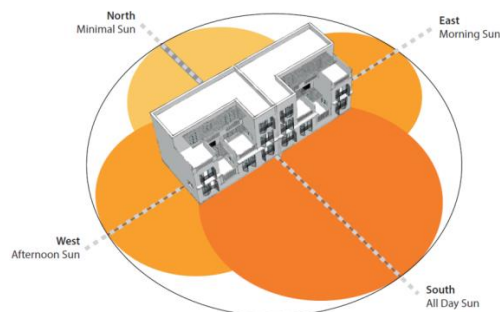
---

<sup>1</sup> Associate Professor at Faculty of Architectural Engineering, International Balkan University, Republic of N. Macedonia [vmangaroska@gmail.com](mailto:vmangaroska@gmail.com)

<sup>2</sup> Professor at Faculty of Architectural Engineering, SS Cyril and Methodius University, Republic of N. Macedonia [kmangaroski@yahoo.com](mailto:kmangaroski@yahoo.com)

## 1. INTRODUCTION

The renewable technologies have raised important awareness among architectural engineers. The concept of building integration photovoltaic system for architects is a new opportunity for integration to the architectural design. Solar energy as source is free, infinite and non-polluting renewable energy technology source. Solar energy can be used in active and passive way. Passive use of solar energy is defined by the direct use of solar heat gains in the buildings, and active use of solar energy is defined with solar thermal collectors and photovoltaic panels [1]. The analysis of the orientation of passive house standard building in order to maximize the thermal heat gains should be with elongation in east-west axis with direction towards south side for the northern hemisphere in order to ensure optimal heating, cooling and lighting from the sun radiation (Fig 1). Passive solar design should have optimal solar radiation for the building to receive direct solar radiation in winter when heating is the main issue and much less in summer, when cooling is the main issue.



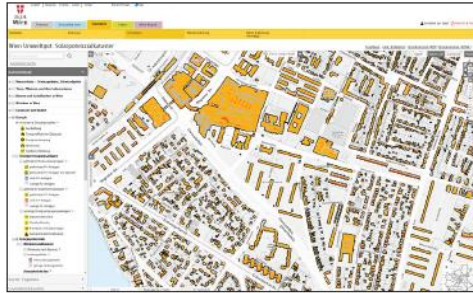
*Fig 1. Solar radiation in different orientations for Passive House design, Source: Guidelines for Sustainable Energy Efficient Architecture, TU Berlin, 2014*

### 1.1. Analysis of urban planning methodology for optimization of solar energy

Analysis of urban disposition of the solar radiation in the cities is important factor in conceptualizing the intersecting systems as a basis for architectural study of buildings' orientation for optimizing their solar potential. The study of urban orientation for solar energy optimization should include several urban location components, such as: terrain configuration, insolation orientation, wind orientation, correlation between buildings and system of buildings.

The selection of the location for the analysis of optimal photovoltaic impact, incorporates analysis of the solar radiation, climate, geographical-technical conditions of the location, topography of the terrain, land use, urban regulations of the land and urban zoning [3], environmental conditions and the regulations for protection of the environment, conditions for connection to the grid-tie system, pollution module, protection from fire hazards and financial incentives.

Urban planning tendencies in the modern cities in the recent years include analysis of optimal utilization of the solar photovoltaic effect by creating specialized Master plans (Fig 2). These Master plans use sophisticated computer programs that analyze daylight and maximal utilization of the photovoltaic potential of individual buildings in the cities.



*Fig 2. Online Solar Cadastre of City Vienna, Source. Solar Cadastre, Vienna, Austria*

The assessment methodology and tools that cities actively use nowadays is the production of online solar city 2D and 3D maps, which can give building owners an indication of the photovoltaic solar energy potential of their roofs, and for some cities solar potential of facades. (Fig 3) These Solar 2D and 3D maps are important assessment methods and tools for the individual and collective companies' owners to get accurate information regarding the solar potential cadastre for the optimal photovoltaic potential of their buildings.



*Fig 3. Copenhagen Solar Map, Source: Solar Map of City Copenhagen, Netherlands*

Another methodology which is actively used is the geographic information system SolarGIS mapping tool. It is used in the process of the site selection process for optimal PV potential. The GIS mapping methodology can be actively used to define constraints on a given location, and analyze the total area available for PV development. The GIS mapping can define the amount of solar radiation mostly affected by the latitude of the site and its local climatic characteristics. The geographical position and climate in the Republic of Macedonia offer a very high photovoltaic power potential. According to the solar radiation measurements of the Hydro-meteorological service, the annual average daily radiation is 3 kWh/m<sup>2</sup> Skopje in the northern part of the country and 4 kWh/m<sup>2</sup> in Bitola in the the southwest of the country. (Fig 4).

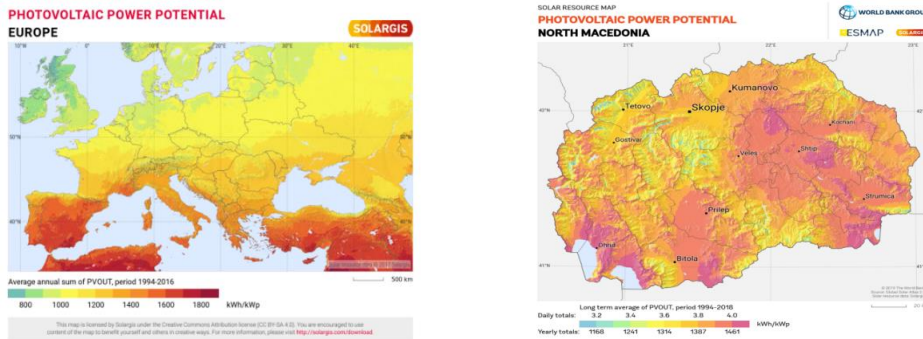


Fig 4. SOLARGIS, Photovoltaic Power Potential in Europe and North Macedonia, Source: SolarGIS, World Bank Group

## 2. METHODOLOGY OF BUILDING INTEGRATED PHOTOVOLTAICS

Solar renewable technologies and building integrated PV systems create new possibilities for important International architectural studios to be analyzed as architectural elements in architectural design.

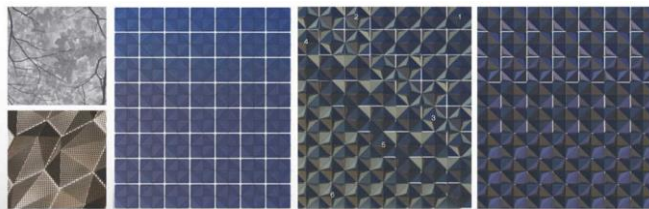
Photovoltaic systems can be applied in architectural building in two ways: in the existing system as building applied photovoltaics or building integrated photovoltaics when the architects substitute building element: roof, facade, shading element, and parapet. The architect can also choose the typology, size, color and transparency of the photovoltaic modules. Building integrated photovoltaics have more architectural function to the building, than only energy production. Building integrated photovoltaics modules should primarily correspond to the technical aspects of the energy production, as well as, be integrated as architectural elements according to the function of the building envelope: adaptive facade, double facade, PV shading cladding systems in the architectural buildings [4]. The economic benefit of installing building integrated photovoltaics is that it will be profitable and it will reduce the transmission losses in the electricity network. Building Integrated Photovoltaics are defined as photovoltaic modules that have double function: energy and architectural function, in order to replace the standard structural elements in the buildings. There is production of electricity and from architectural aspect there is replacing of the traditional building materials with photovoltaic modules which bring significant savings by replacing building material.

Photovoltaic cells in the building integrated photovoltaics are the main integration element. They have semiconductor materials that have better efficiency according to their different structures. Silicon is the most used pure semiconductor material for the production of photovoltaic cells in a form of monocrystalline, polycrystalline and amorphous silicon. Photovoltaic cells with the highest level of efficiency are using dark blue anti-reflective material coating. Comparing to them thin-film modules have lower efficiency, but they are cheaper and require less material in the production. The thin-film modules can be used in industrial buildings and buildings with large areas. Types of photovoltaic modules that are most frequently used in building integrated photovoltaics are: mono-crystalline, poly-crystalline and thin-film modules, which have different level of light absorption, energy efficiency, manufacturing technology and cost of

production. Mono-crystalline modules are highly efficient as blue black modules that have efficiency in good light of 15%-20%. (Fig 5). Polycrystalline photovoltaics are mostly used solar panels, even though they are less efficient. Thin film modules are more flexible and they can be produced in different colors, textures and shapes, and the material for their production is cheaper compared to other types of photovoltaics (Fig 6).

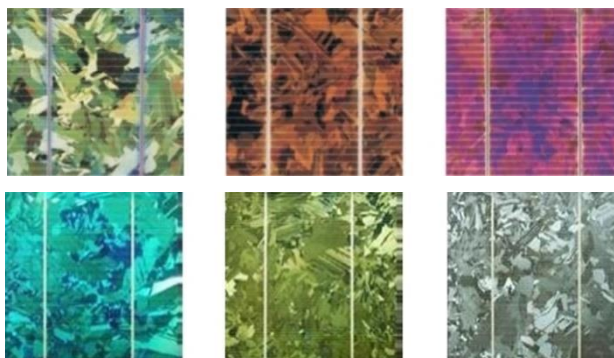


*Fig. 5 Types of Crystalline Building Integration PV Cells*



*Fig 6 Photovoltaic Panels Patterns with specific architectural design*

Structure of the cells is very important factor in the design of building integrated photovoltaics. They are available in a different shapes, sizes and models from insulated glass structure to sound iso-glass. The cell has possibility to have daylight enter the building according to the distribution and arrangement of the photovoltaic cells. The arrangement of photovoltaic cells will contribute to the aesthetics of architectural design, and will also contribute to the energy production according to the higher density of the cells. These types of modules are recommendable in architectural buildings that require high level of integrity and architectural aesthetic design result. Very important factor in the design of the building integrated photovoltaics is the choice of color in the architectural design.(Fig 7) with consideration of energy production, since lighter colors of photovoltaic cells provide lower energy production [4].



*Fig 7. Color varieties in the photovoltaic cells in Solar Innova modules*

Integration of photovoltaics can be done in the following building areas: roofs as ideal places for building photovoltaic integration that provide large unused

surface, skylights and roofs with glass structure which can create diffuse lighting and can combine photovoltaic installation, facades which can add building integrated photovoltaics in different ways such as: glass structure, ventilated facade, shading elements that provide shading and aesthetics.

The Project which will include integrated photovoltaics should analyze both aspects: the production of electricity and the architectural design and daylight from the beginning of the architectural project. Building integrated photovoltaics system should analyze the optimal orientation and angle, as well as the load and stability of the construction of the building. The project should present different scenarios with different type of modules in terms of their energy efficiency, architectural aesthetical design and economic aspects of the photovoltaic modules, in order for the investor of the project to decide which system will be chosen in a calculations of long-term effects and benefits as a best solution in terms of production of electricity or photovoltaic cells design.

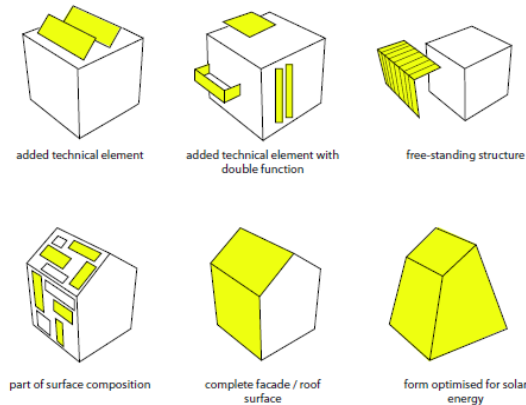
It is very important to have into consideration the fact that the integration of the building photovoltaics should comply with the principle of energy production and daylight to the building. Customized photovoltaic cells can create interesting light effects in the corridors or interior design in the building as a light and shadow effect [4]. In the system of integrated building photovoltaics, special attention should be added in terms of providing adequate ventilation, and this can be solved with a planned ventilated space and space for ventilation between the modules. Also, ventilation should be provided for the inverters for optimal usage of the photovoltaic system. The Photovoltaic system needs to be monitored by the energy technology institutes, which will determine if there is a malfunction in some of the modules which will reduce the overall energy production, identify the irregularities and replace the malfunction of the module. Electrical engineering should provide all technical energy calculations. Also, it is important to determine the shades in the photovoltaic system, because they can reduce the production of electricity even in a situation of partially shaded PV modules. The Photovoltaic systems can be also created by adding battery storage units which can store the accumulated electricity. Photovoltaic systems can be part of circular recycling, and this process can be done in thin film and silicon modules in terms of the materials glass, aluminum and semiconductor materials, which will reduce their production costs and have positive impact on environment as a principle which needs to be explored by architects and electrical engineers.

### **3. RESULTS - BUILDINGS INTEGRATED PV AS ARCHITECTURAL DESIGN ELEMENT**

Photovoltaic panels as architectural design element should incorporate the formal aesthetic aspects in architectural design with the concept of integration of photovoltaic panels according to the International Energy Agency (IEA) as the following principles: added technical element, added technical element with double function, free-standing structure, part of surface composition, complete facade or roof structure or form optimized for solar energy (Fig 8) [5].

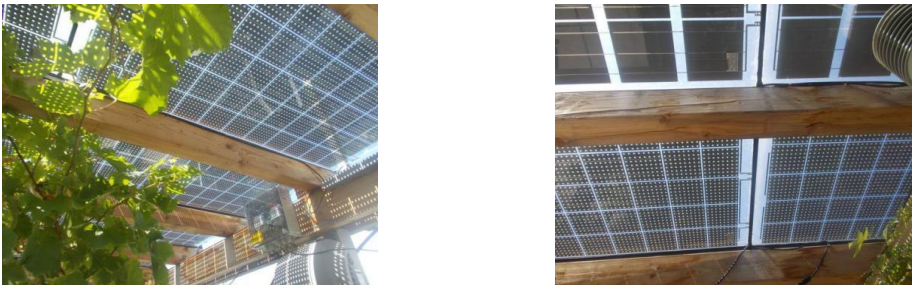
The levels of implementation of the building integrated photovoltaics can be: basic, medium and advanced. Basic level requires formal flexibility of the modules and typically includes retrofit projects. Medium level of integration

includes the non-active elements with added function: cladding and shading elements. Advanced level of integration provides a complete roof or facade system that is usually custom-made and includes all interface PV systems [5].



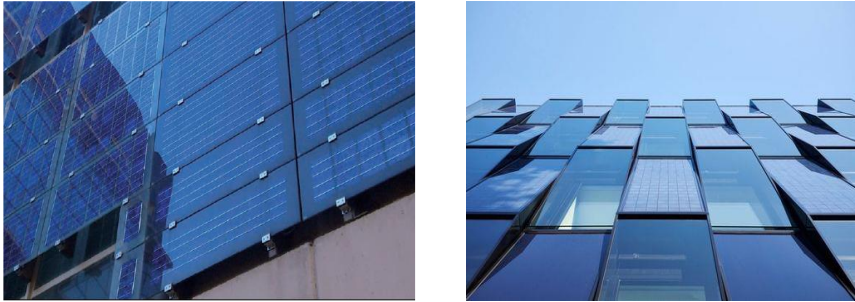
*Fig 8. Architectural Aesthetic Design for integration of PV panels, Source: Illustration from IEA analysis of positioning and integration of PV Panels, Solar Energy and Architecture*

Roofs are usual architectural element in application of building integrated photovoltaics (Fig 9). They have great variety of photovoltaics according to color, size, shape and transparency. The photovoltaics can be implemented on the roof with existing structure, or they can be implemented on the roofs which contribute to their efficiency and environmental aspects.



*Fig 9. Rooftop with Photovoltaic Panels at the University für Bödenkultur, Vienna, Austria*

Facades and skylights provide new aesthetic possibilities to the building. The new innovative technological development leads to integrating building photovoltaics on the building envelope surface (Fig 10). Building integrated photovoltaics can be implemented in modern architecture as ventilated curtain wall. This system has load-bearing fixing system connected to the building envelope, so the distance between the curtain wall and the structure creates space which ventilates the solar modules and creates good insulation layer [5]. Facades can be designed using different materials with integration to the photovoltaic modules. Ventilated facades are usually part in the architectural design when there is a need for energy efficient renovation facade.



*Fig 10. Ventilated Facade as an integrative Photovoltaic Architectural Element*

The architects have methodology to combine different morphology of shapes, colors and patterns in the building integrated photovoltaics, by approaching the design with customized photovoltaic cells with modern sophisticated renewable design using the photovoltaic technology. One of the new innovations in terms of photovoltaics technology is the photovoltaic solar transparent glass, as an innovative high-tech building material. It can integrate solar photovoltaic sell easily in the glass structure while producing energy and have transparent appearance that bring daylight in the building. This system is applicable in architectural design of buildings with different functions, but it is especially recommended in office buildings and buildings with business premises [6]. Morphological characteristics of integration of PV cells are: medium for energy production, form of the module, size of the module field, materials of the module, texture of mono-crystalline silicon, absorption of solar energy, color, size and shape of the modules.

The usage of building integrated photovoltaics in the facades can be achieved as different solutions, because facade is very important architectural design element that is observed first when a visitor approaches the building. The facades which use integrated building photovoltaics are multifunctional, on one side they provide production of electricity, create thermal and noise insulation to the building, and on the other side they represent innovation with aesthetic character to the building where the panels become the integral part of the building facade. Laminated glass is recommendable and applicable in a cladding glass facade where the parapet is designed in a safe laminated glass that holds together when it is broken. It is also used in areas where precautions of high wind resilience are needed. It gives high sound insulation and blocking of most of the UV light.

Building integrated photovoltaics with the architectural design incorporate functionality, construction and aesthetics of solar renewable technology. Architects can design fully the shape of the building in accordance to the optimal energy production. The famous architectural slogan from the architect Luis Sullivan “Form Follows Function” is shifting into a new contemporary concept for all architects “Form Follows Energy”, which can be seen as a principle in the Energy Base Building in Vienna (Fig 11).



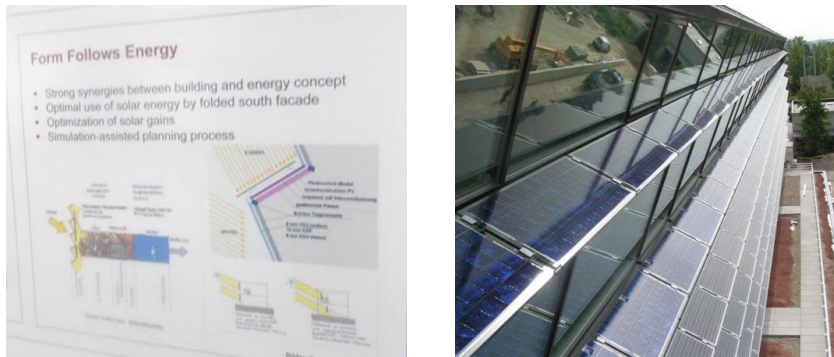


Fig 11. Energy Base Building, AIT, Vienna, Austria, Source Author

Skylights are ideal place for positioning integrated building photovoltaics, because they have slight incline angle, and the photovoltaic panels can create effects of light and shadows providing daylight. Photovoltaic systems in this type of construction are semi-transparent because they allow light inside the building. They provide thermal, solar and sun protection and selective natural light as semi-transparent photovoltaics, as well as great visual elegant effects.

Integrated building photovoltaics can be also implemented in the balcony as an architectural element. This system is particularly recommended when the balcony is highly exposed to sun radiation for optimization of energy production and improvement of visual appearance. In this situation multi-layer safety glass with unlimited design possibilities should be used. [7].

Shading architectural elements as integrated building photovoltaics are effective and alternative element to generate electricity, which replace traditional elements for shading systems, filter the UV radiation, help raise awareness of the citizens for energy production, integrate renewable energy in urban areas, capitalize from the unused urban structures and create rational economic profitable usage. In this architectural element both aspects are combined: energy production and functional formal aspect of shading.

Position of the integrated building photovoltaics can be in parking areas, which can contribute directly in charging batteries from the electric cars. The design is typically based on integration of parking modules for two cars with integrated photovoltaics with an incline of 8 degrees for rainfall system. The photovoltaic area should have maximum possible energy production, protection of weather influences: wind, snow and rain weather conditions [7].

Architectural Project worked during the architectural design studios in the course Sustainable Architecture at the Faculty of Engineering, Department of Architecture at International Balkan University implemented building integrated photovoltaics (Fig 12). The objectives of the sustainable project were to improve the architectural functioning of the building with implementation of renewable technologies: solar panels, photovoltaic panels, geothermal pumps, green roof system, to improve the connection and between public buildings: municipality building by promoting the use of renewable technologies.



Fig 12.. Diploma Architectural Project, Student: Kubra Hodo, Mentor: Assoc. Prof. Dr Viktorija Mangaroska

#### 4. DISCUSSION

Building integrated photovoltaics are becoming more important in the field of contemporary sustainable architecture as new way of renewable solar energy application. They incorporate functionality, construction and aesthetics in architectural design [8]. The Photovoltaic modules should provide and ensure the highest quality standards of quality, safety and design. The criteria for achieving high architectural quality of the building integrated photovoltaics are defined by the International Energy Agency through Program for Photovoltaic Energy [5]. International Energy Agency Program defines the following criteria: “natural integration of PV systems, PV systems that satisfy the architectural context of the building, quality materials and color composition, PV systems that fit well with the existing modular division, visual aspect of the network that is in harmony with the building and makes a good composition, PV systems appropriate for the context of the building and whose integration is well designed, the use of PV systems that challenged the innovative concept.”

The standards of implementing building integrated photovoltaics in the building envelope, should specifically be defined by architects in order to create protection from wind, rain noise and intrusion, provide thermal insulation in cold winter and extreme summer heat, provide regulation for daylight, fresh air and passive solar gains. Special attention should be given in the architectural design of the integration of the photovoltaic modules in opaque and transparent parts of the building for providing daylight function and passive solar thermal gains, as well as visual contact with the outside, and provide natural ventilation. Structural aspects that need to be considered when installing building integrated photovoltaics are to calculate the module load to the load bearing structure, to pay attention to avoid thermal bridges, to pay attention to provide fire protection and weather impacts, and create modules which will resist the wind loads and impacts [9].

Advantages of using building integrated photovoltaics are: energy production, economic investment, reducing the carbon footprint and environmental protection, facade elements that can have noise reduction and thermal insulation, and saving on the innovative building materials compared to traditional materials. The produced energy can be used by the building directly without any transportation costs, or it can also be sold to the grid as a grid-tie

system [10]. Advantage of the integrated photovoltaics is that they are mostly suitable in cities and urban environment due to the quiet and clean production. Other advantages of the building photovoltaics are: innovation in contemporary and modern architectural design, customization of photovoltaic panels for specific architectural building, integration and aesthetics to the urban environment. Building integrated photovoltaics can perform the same function in all areas of the building facade, compared to standard photovoltaic modules that can be placed on the flat roof structure in a specific angle. The modules and the photovoltaic solar cells in the integrated photovoltaics can be custom-made according to the architectural design and customer requirements for different architectural visual appearance of shape, color, patterns.

## 5. CONCLUSION

Architectural characteristics of building integrated photovoltaics are: functional, constructive and aesthetics formal aspects in the architectural design. Building integrated photovoltaics include the following characteristics in the architectural design: sustainable renewable energy production, reducing the energy consumption and improving energy efficiency. The decision regarding building project with photovoltaic panels, is defined by several factors such as analysis of energy production, economic aspect and cost estimation, payback period, value and benefits on the energy production and the aesthetic of the building, environmental, social-economic and architectural long-term benefits of the building, photovoltaic cells in relation to their energy production, non-reflective surfaces, maintenance of the structures and possible replacement and recycling. Architects must think of new concepts of integration of the photovoltaic systems as architectural elements by creating pixel photovoltaic module, patterns in monocrystalline cells, as well as using different visible materials, patterns, textures and color in the film modules of the photovoltaic cells in the composition of the architectural design.

Building integrated photovoltaics in architectural design studios are starting to emerge from the concept of new innovative engineering methods in a stylistic aesthetics and optimization processes towards new modern contemporary and sustainable style in architecture. It is becoming very important for architectural engineers to have knowledge in the early architectural design phase for better integration of photovoltaics in terms of aesthetic, energetic, constructive and economic aspects in the architectural design of the buildings. Architects should particularly pay attention to the selection of the photovoltaic cells that will bring aesthetic value to the building, as well as the function of the integrated panels, such as thermal insulation, waterproof materials, fire protection, wind protection, acoustic insulation, daylight access, shading, color and transparency of the designed photovoltaics [11]. The usage of renewable energy and the reduction of energy consumption, in terms of sustainable modern architecture becomes important factor in the early architectural design phase for many famous architectural studios around the world. Engineering sustainable concept and paradigm start to shift as an architectural element in the sustainable parametric design of the 21<sup>st</sup> century. This concept of sustainable design in architecture with

building integrated photovoltaics leads the contemporary transformation of the design process of the next generations of architectural and civil engineers.

## REFERENCES

- [1] Bouwmeester, Henk. "Bouwen op de zon. Eindeloze energie in een duurzame wijk/ **Building Solar Suburbs. Renewable energy in a sustainable city**". *Boxtel: Aeneas* ISBN 90-75365-19-5, 1999
- [2] <https://www.gradjenivarsvo.rs> (November 2022)
- [3] International Energy Agency, **Designing Photovoltaic Systems for Architectural Integration, Criteria and Guidelines for product and system developers, Solar Energy and Architecture** - International Energy Agency - Solar Heating and Cooling Programme Report T. 41.A.3/2: Task 41 IEA SHC *Solar Energy and Architecture*, 2015 (p. 45-67)
- [4] Solar Innova, **Katalog Solarni paneli BIPV** Personalizirani <https://www.solarinnova.net> (November 2022)
- [5] **Guidelines on building integration of photovoltaic in the Mediterranean area**, *European Union, ENPI CBC Mediterranean Sea Basin Programme* (p. 31-35), 2021
- [6] **Project and Installation of Photovoltaic Systems**, *Trainee, EU Horizon 2020*, pp. 25-29, Skopje 2019
- [7] <https://www.iea.org/reports/solar-pv> (November 2022), *International Energy Agency Photovoltaic Power Systems Programme*,
- [8] Humm, Ottmar; Toggweiler, Peter. "**Photovoltaik und Architektur - Die Integration von Solarzellen in Gebäudehüllen**". *Basel: Birkhäuser*. 1993. ISBN 3-7643-2891
- [9] Hagermann, Ingo B. "Gebäudeintegrierte Photovoltaik. Architektonische Integration der Photovoltaik in die Gebäudehülle" *Köln, Rudolf Müller*. 2002. ISBN 3-481-01776-6
- [10] DGS (Ed.). "**Planning and installing photovoltaic systems: a guide for installers, architects and engineers**" *London: James & James*, 2005
- [11] P. Schumacher, Parametric Order – **Architectural Order via an Agent Based Parametric Semiology**, published in: *Adaptive Ecologies – Correlated Systems of Living by Theodore Spyropoulos, AA Publications*, 2013

# THE INTEGRATION OF GREENERY IN ARCHITECTURE AS AN APPROACH TO ROOFTOP EXTENSION

Ivana Miškeljin<sup>1</sup>, Igor Maraš<sup>2</sup>

## Abstract

*A research topic is an experimental approach to rooftop extension by integrating with nature. The aim is to simultaneously address two value issues: the necessity of increasing greenery and the densification of the existing city. Adding greenery on top of the existing building contributes to the well-being of the entire neighbourhood. This is especially important if there is no possibility of placing greenery at the ground level. The new architectural space adds life to the rooftop and saves land resources. The idea is to contribute to the overall concept of sustainability. The integration of greenery can be applied in the organisation of private and public spaces on the rooftop extension of the existing building. The paper analyses two architectural projects as two specific architectural experiments of the authors. The first project relates to the design of row houses with private gardens on the roof of a building in Novi Sad. In the second project, the idea is to create a public park area with additional public programs on the roof of the existing building. Here the greenery is shaped to form a covered public square.*

**Key words:** architectural design, greenery, rooftop, comfort, activities, aesthetic

---

<sup>1</sup> PhD, associate professor, University of Novi Sad, Faculty of Technical Sciences, Trg Dositeja Obradovića 6, Novi Sad, Serbia, mivana@uns.ac.rs

<sup>2</sup> PhD, associate professor, University of Novi Sad, Faculty of Technical Sciences, Trg Dositeja Obradovića 6, Novi Sad, Serbia, imaras@uns.ac.rs

## 1. INTRODUCTION

Designing green roof gardens on the top of existing buildings and as an integral part of the new buildings would increase the amount of missing green areas in the city per capita. Green roof gardens can be seen “as a strategic element for the overall regeneration of the urban system and as an architectural element identifying the design culture of our time” [1]. A topic of this paper is the analysis of architectural projects, as specific architectural experiments of the authors, in which greenery is an integral part of rooftop extension. The theme is the exploration of aesthetic ideas of connecting greenery and architecture. The purpose is to create a place identity based on comfort and well-being. An important aspect of green roofs is who they belong to, i.e. the topic of maintenance.

### 1.1. Living Material as an Integral Part of the Aesthetic Idea in Architecture: Comfort, Activities and Identity

If we consider greenery an architectural material, new design solutions can emerge. Traditional architectural materials cannot grow but only age. On the contrary, vegetation, as a living material, can grow. For this reason, considering greenery as an integral element of architecture is particularly intriguing. The notion of nature and beauty are intuitively often seen as inseparable. In "History of Beauty", the Beauty of nature is an integral part of the book through different chapters, i.e. epochs [2]. In the chapters "Palaces and Gardens" and "The Poetics of Ruins", nature and architecture form an integral part of the idea of Beauty: „...in the eighteenth-century ruins were appreciated precisely for their incompleteness, for the marks that inexorable time had left upon them, for the wild vegetation that covered them, for the cracks and the moss.“[2]. Aesthetic ideas that create stimulating connections between architecture and nature are not new. Throughout history, these ideas are a consequence of the sociocultural context in which they arise. Today, with the development of new technologies and the need to increase greenery in the city, this topic is gaining even more importance and new possibilities.

The essence of these aesthetic ideas that integrate vegetation and architecture is to improve comfort. Green roofs contribute to sound [3] and thermal insulation, i.e. higher-quality interior space. Regarding green roof thermal properties, “the surface temperature of the green roof varies according to the different kind of vegetation, which exists in the various places” [4]. A green roof garden with new architectural space on the top of the building produces new activities. Vegetation, with its dynamics of transformation of scents and colors, i.e. vegetation phase, contributes to the essential atmosphere and comfort of the space. Creating new activities in the rooftop garden is beneficial for multiple senses. Material is a crucial element for atmosphere production in architecture [5], and in this case, greenery as a material in architecture is essentially significant. Activating the roofs brings new views to the surroundings and the perception of the city. Also, the green roof gardens are making new connections with the context [1] and adding benefits to the neighborhood.

Based on the above-mentioned, integration of greenery in architecture as an approach to rooftop extension can be seen as a principle of creating space with a great identity. In this way, it is possible to contribute to the diversity of residential and public spaces.

Integration of living nature in architecture demands a multidisciplinary approach. Exploring architecture as a hybrid of technology and nature can be used in purpose to create a better living environment for humans [6]. The research of Ferdinand Ludwig's "Baubotanik" - the "construction method that uses living plants for load bearing in architectural structures", is significant topic [7]. Ishigami, in his approach to „freeing architecture“[8], aims to soften, blur and reset boundaries between architecture, landscape architecture, art, and environmentalism (project "Art Biotop Water Garden"). David Nash's artwork "Ash Dome" (1977–ongoing) is an abstract and living sculpture [9]. Learning from the world of art can be very encouraging for architects. How artists treat greenery and nature in their site-specific artworks can improve the quality of ideas in architecture and lead to a more sensible creation of space.

### **1.2. The Question of Property and Maintenance of Green Roof Gardens – Public Parks and Private Gardens**

We have witnessed that even when there is a will and financial support for the implementation of greenery through roof-top extensions, ownership issues and insufficiently defined regulations result in poor maintenance and deterioration of these green areas. In the case of roof-top greenery of public buildings, the lack of financing and maintenance services leads to the decay of these areas. Also, those spaces are public by ownership, but in most cases their use is limited in terms of users and services that maintain them. On the other hand, in the case of roof-top greenery of multi-family residential buildings, the legal regulations place these spaces in a very indeterminate area. They are in a loose "zone" where it is collective by ownership and private by use, and as result of that obligation of maintenance are usually insufficiently defined. This leads to the fact that any type of appropriation by an individual or group to use and maintain such areas is seen as a violation.

In both cases, the indeterminate position in terms of ownership, maintenance and use prevents these spaces from being an integral part of the system of green and public areas of the city. In the case of multi-family residential buildings, changes in regulations in terms of ownership, exemption from paying for these areas when buying apartments, etc. would certainly contribute to more clearly defined rights of use and, therefore, obligations to maintain these areas. In this way, individuals or groups could appropriate these spaces by actively using them as collective spaces for private use - private gardens. On the other hand, the problem of roof-top greenery of public buildings in terms of availability and accessibility can be solved with different design approaches that would enable these spaces to actively participate in the system of public spaces of the city, but in such a way as not to endanger the function of the building. Spaces designed in this way would certainly be a good contribution not only in terms of sustainability and energy efficiency of those facilities, but their inclusion as part of the public park system would certainly contribute to a better-quality environment.

## **2. METHODOLOGY**

Before the design process, it is necessary to analyze the key aspects and synthesize them through the project task. These include an analysis of the technical

possibility of extending the existing roof and greenery implementation; program analysis (depending on whether it is housing or public space) and defining ownership of the roof garden; and analysis of access to the roof garden.

Program, context and materials are essential for defining a site-specific aesthetic idea in architecture. According to Winters, "In architecture, the main concern is what use is to be made of the artistic object, and this use is a condition to which the aesthetic ideas are confined." [10] Designing a space with a strong identity implies the development of sensible aesthetic ideas that uniquely integrate activities, greenery and context. In the continuation of the Paper, architectural projects are described as specific architectural experiments of the authors.

## 2.1. Row Houses with Private Gardens on the Flat Roof of a Building in the City Center of Novi Sad

Houses with private attached gardens on the roof of the building would contribute to the diversity of the offer of apartments in Novi Sad. The quality of an apartment with a private garden in the city center would attract a particular group of apartment buyers. Some new residential complexes in Novi Sad even include the word park in their commercial names, although the architecture of the building does not include greenery. But, it shows that investors have recognized the topic of greenery as a vital quality that they want to attract potential buyers.

The architectural experiment that is the topic of this subchapter is a complex of row houses with attached private gardens that would be positioned on the roof of a building in Novi Sad. This topic was considered through two situations: 1. Row houses designed at the top of an existing building – "A hidden world in greenery" 2. Row houses with gardens as an integral design of a new mixed-use building.

### 2.1.1. Row Houses Designed at the Top of an Existing Building – "A Hidden World in Greenery"

The row houses are hidden in layered private gardens. Surrounded by greenery, these houses are invisible from a pedestrian's point of view. For passers-by, the rooftop extension is only perceived as a green oasis on the roof. (Figure 1). For tenants, the interior space (as a hidden inner world) that opens onto private gardens is of essential importance. These two different points of view from which space is understood form the basic logic of the project.

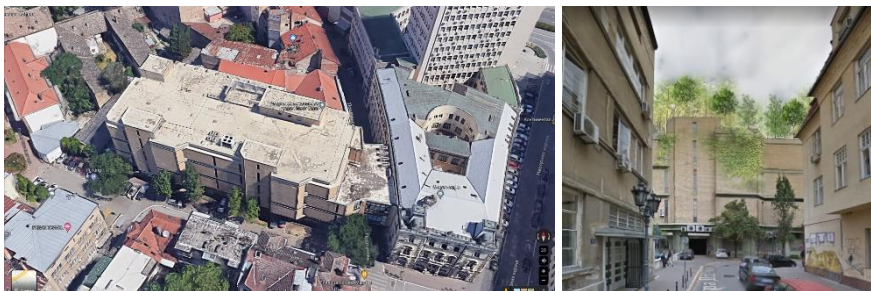


Figure 1. Left: Existing building (source: google maps); Right: 3d view of integration greenery at the rooftop (Source: authors).

Greenery is a layer around the new architecture on a rooftop. Townhouses (6 residential units) are modular structures. Two separate staircases provide access to the roof gardens and residential units. The functioning of the existing archival



building (archive of a post office building) is independent. The aesthetic idea unites opposites: the modular structure of housing spaces and the diversity of small attached gardens on the roof. Each tenant would create a private garden according to their needs. And it would be valuable for tenants to design their gardens based on the recommendations of a landscape architect. Recommendations should be defined based on the analysis of greenery on the entire parcel and immediate surroundings. Research has shown that “the benefits are considerably increased when the green areas of the residential gardens are planned and designed through a holistic GI-oriented (Green Infrastructure) design approach based on the total building parcel.”[11]

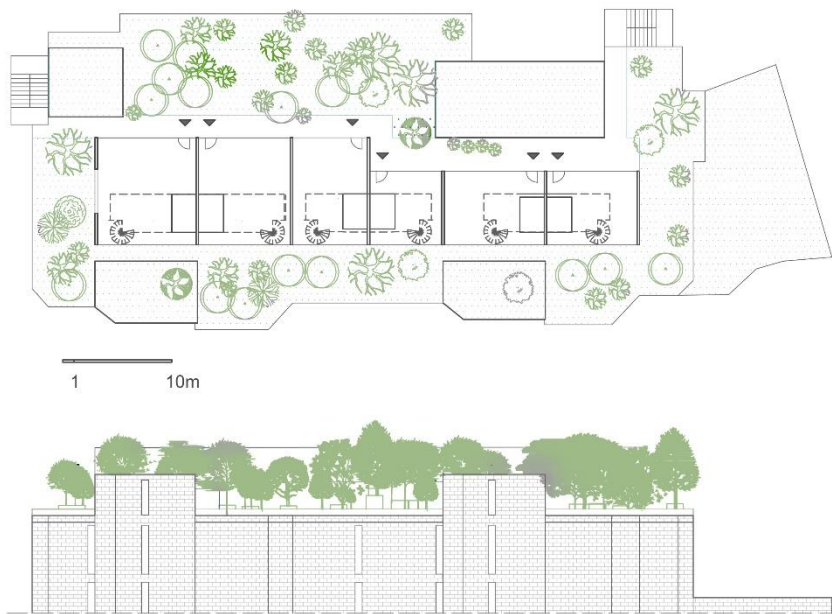


Figure 2. Plan and elevation of rooftop extension. Source: authors.

### 2.1.2. Row Houses with Gardens as an Integral Design of a New Mixed-use Building

A mixed-use building is conceived as a complex that integrates a park with retail, cafe and housing. The lower floors (retail and cafe) consist of large open interiors with a public park, while the roof is intended for housing with private gardens (access provided with separate staircases). The building was conceived to be located on the corner of Ilije Ognjanovica and Modena Streets and was designed as a part of an architecture competition proposal [13]. These private gardens are conceived as oases and buffer zones from the dynamic city life in the city centre and are further elaborated on in the graphic attachments shown.

The idea of the project is to create an *enfilade* space by connecting housing and private gardens. Therefore, the research topic is *enfilade* “alignment of all the doorways in a series or suite of rooms so as to create a vista when the doors were open, as in a palace”[12] in the contemporary context. A module was used to determine rooms and gardens. Connections between modules are defined through the *enfilade* concept. The result is a multifaceted visual connection between the

rooms and the gardens. In other words, the organization of the space consists of the alternating interweaving of the rooms and the gardens (Figure 3 and 4).

The belt of the garden towards the street is the connection with it. It filters sounds and gives privacy. The gardens in the atriums provide complete privacy. The proposed enfilade concept enables the gradation of the intimacy of private gardens. The result is that the room (living room, dining room or bedroom) opens into multiple gardens with varying degrees of privacy.



*Figure 3. Top image: 3d view of the building in the context, winter (source: Kabinet 505, competition entry [13] – authors are members of the Kabinet 505 team); Middle and bottom images: 3d view of rooftop and interior design (source: authors)*

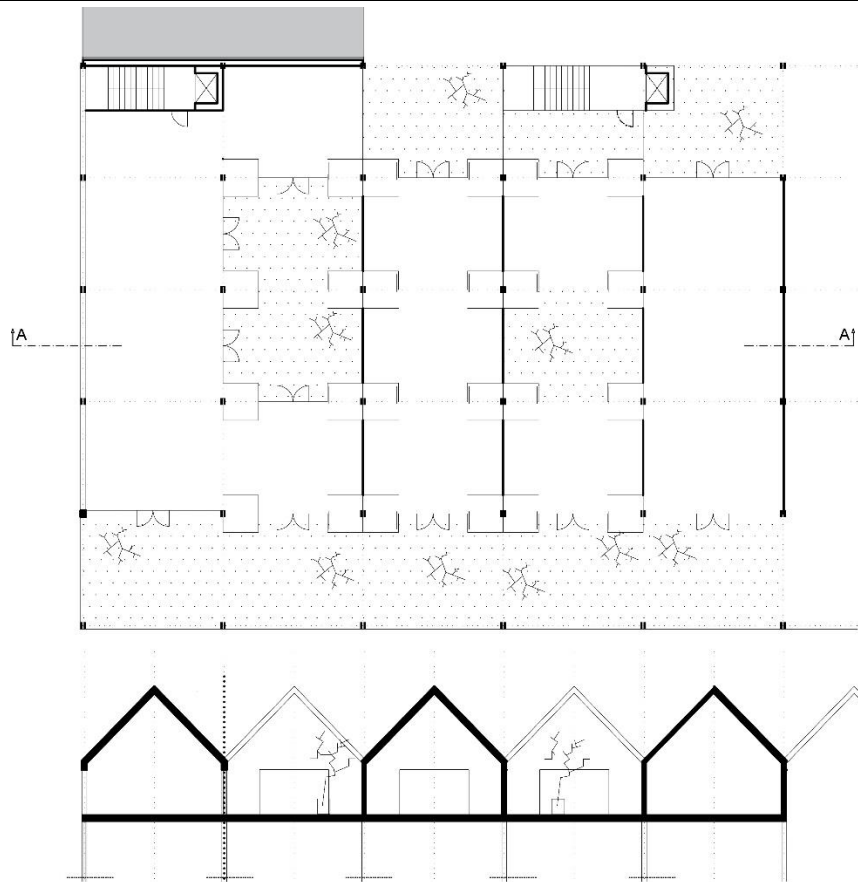


Figure 4. Plan and section of rooftop (source: authors); 3d view of the building in the context, spring (source: Kabinet 505, competition entry [13] – authors are members of the Kabinet 505 team).

## 2.2. Art Gallery and Covered Square on the Roof of an Existing Building in Novi Sad – “Virginia Creeper Canopy”

The project task is a rooftop extension with an art gallery and garden. This experiment uses the same archival building (archive of a post office building in Novi Sad, see Figure 1) to extend, but this time with public content (architectural program).

The idea of the project is to create a covered square using greenery as an essential material on top of an existing building. The role of vegetation is to protect the activities that would take place on the roof area. Adding new life (art activities + greenery) to existing buildings brings well-being to the neighbourhood. Covered and illuminated at night, the square on the roof of the building creates a specific atmosphere and is suitable for various activities related to the art gallery.



Figure 5. Creepers *Parthenocissus quinquefolia* (Virginia creeper). Variety of colors in autumn in the same garden. All photos are taken on 16. October 2022. (Melenci, Vojvodina). Source: authors

The architectural structure consists of a gallery building and an elegant metal canopy covered with greenery. Greening is planned with plant species planted on the flat roofs of the art gallery and existing archival building. Creepers *Parthenocissus quinquefolia* (Virginia creeper) 80% and *Wisteria Sinensis* 20% are shaped to form a covered public square. The greenery of the rooftop extension includes bushy vegetation: *Berberis atropurpurea*, *Weigela Florida Red* and *Acer palmatum atropurpurea*. *Wisteria* brings a scent to the garden during the blossom period. Vegetation (especially Virginia creeper, which is the most abundant) changes colour to red during autumn. The variety of colours in autumn in the same garden at the same time can be seen in the picture (Figure 5). This forms the basis of the aesthetic idea and the vital element of the identity of the space.

A public park area with an art gallery on the roof of the existing building will bring diversity to an existing network of squares and park spaces in Novi Sad.

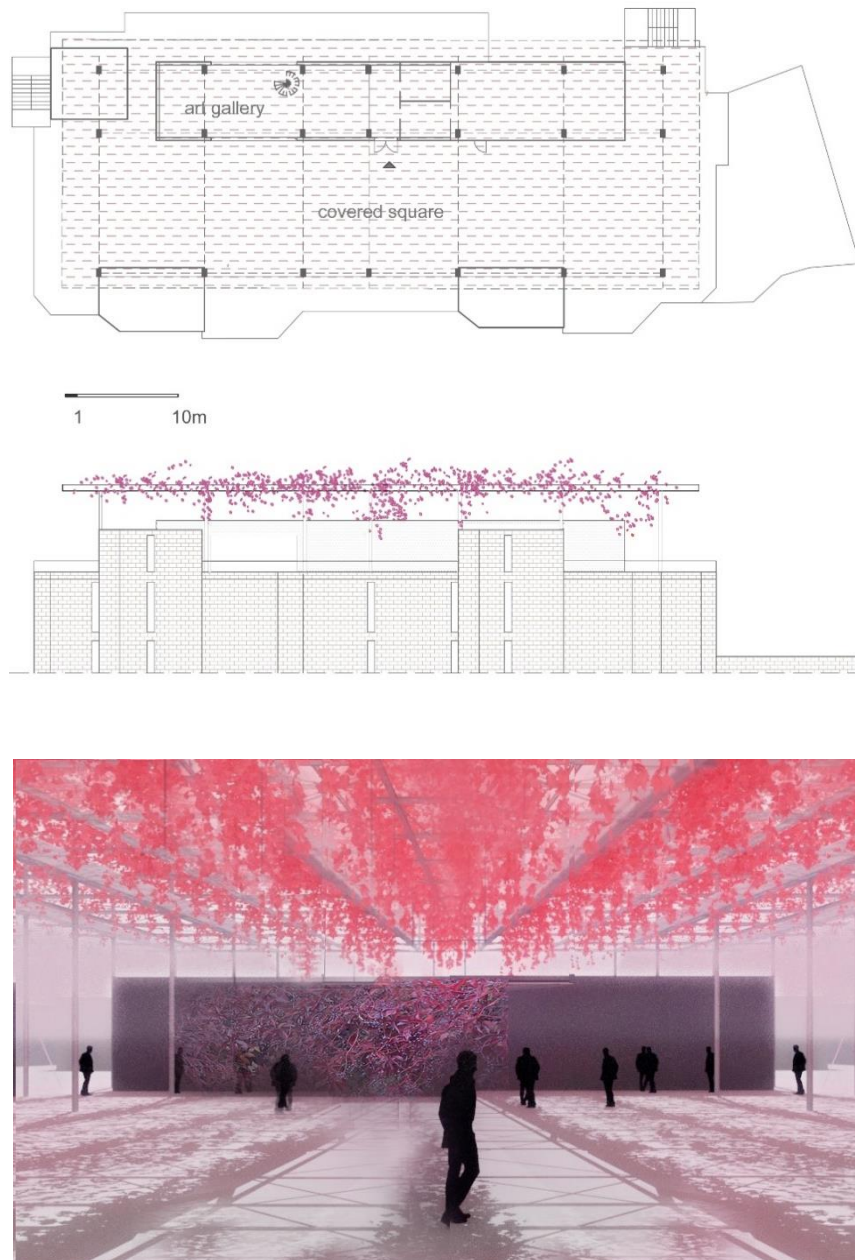


Figure 6. Plan, elevation and conceptual 3d view of rooftop extension: Source: authors

### 3. RESULTS

An integral research approach to the greenery in the architectural design of rooftop extensions can lead to a more sensible architectural space. This includes analysis of activities (architectural program), full potential vegetation as material, and analyses of creating encourage connection with a context. Integral research of these three elements can be synthesized through an aesthetic idea:

Using the enfilade concept in the housing project enables the gradation of the intimacy of private gardens. The result is that the room (living room, dining room or bedroom) opens into multiple gardens with varying degrees of privacy.

Activities (architectural programs) are crucially connected with how integrating greenery. At the housing project, each tenant would create a private garden according to their needs. The result is a free and uneven green oasis on the rooftop. In an art gallery project, greenery has a different role. The rooftop is more open to context, emphasizing the public activities and the structure of the vegetation itself is shaped as a simple memorable gesture. Its programming logic is vividly sun protection.

Houses with private attached gardens on the roof of the building would contribute to the diversity of the offer of apartments at the market.

Integration of greenery in architecture as an approach to rooftop extension can be seen as a principle of creating space with a great identity.

#### 4. DISCUSSION

In the context of using green roof gardens as an element for the regeneration of the urban system, it's interesting to think about the possibilities. In the theoretical consideration of this topic, at the level of data, it would be helpful to apply the MVRD approach, which in their research assumes maximum data (the most extreme state) so that new urban inventions might start to emerge [14]. How much greenery can be added to an existing neighbourhood is challenging and important.

In the practical consideration of green roofs, the question of implementation is crucial. The challenge of property and maintenance of green roof gardens are already described. Also, not all roofs can be considered for expansion. In a UK case study, "the results show that only 9% of the 54 roofs surveyed were suitable for GRs (green roof system) adoption due to the buildings' construction conditions and location"[15]. The topic that could be discussed in further research is optimal technical solutions to the durability of roofs and how the cost of production would be acceptable for our conditions.

#### 5. CONCLUSION

Integration of greenery in architecture as an approach to rooftop extension can be seen as a principle of creating space with a strong identity. It can lead to the diversity of residential and public spaces.

Living material as an integral part of the aesthetic idea in architecture increases comfort and activities. The new architectural space at the rooftop saves land resources. Activation of the roofs brings new views to the surroundings and the perception of the city. Green roof gardens create an essential connection with the context bringing well-being to the neighbourhood.

#### REFERENCES

- [1] Bologna Alberto, Ghersi Adriana, Melli Stefano: **Integrated readings for the urban green roof. Expressive codes and forms of nature.** *Agathón*,

- International Journal of Architecture, Art and Design*, Vol. n. 11/2022, pp. 114-123, 2022
- [2] Umberto, Eco: **On Beauty, History of Western Idea**. *Seeker & Warburg London, 2004*.
- [3] Van Renterghem, Timothy: **Green Roofs for Acoustic Insulation and Noise Reduction** in book: *Nature Based Strategies for Urban and Building Sustainability*, Butterworth-Heinemann, 2018, Pages 167-179.
- [4] A Niachou, K Papakonstantinou, M Santamouris, A Tsangrassoulis, G Mihalakakou: **Analysis of the green roof thermal properties and investigation of its energy performance**, *Energy and Buildings*, Volume 33, Issue 7, 2001, Pages 719-729;
- [5] Zumthor, Peter: **Atmospheres**. *Birkhauser, 2006*
- [6] Widera, B. **Architecture As Hybrid Of Technology And Nature**. *ART & HUMANITIES: Section Architecture & Design*, 3rd International Multidisciplinary Scientific Conference on Social Sciences and Arts SGEM 2016, Vienna, Pages: 81-88, 2016.
- [7] Ludwig, F., Schwertfeger, H. and Storz, O. (2012), **Living Systems: Designing Growth in Baubotanik**. *Architectural Design*, 82: 82-87. 2012
- [8] Ishigami, Junya. **Freeing Architecture**, *Thames & Hudson*, 2016.
- [9] Nash, David: *Making and Placing Abstract Sculpture 1978-2004*, *Tate*, 2014.
- [10] Winters, Edward: **Aesthetics & Architecture**. *Continuum International Publishing Group*, London, 2007.
- [11] Sekban Demet Ulku Gulpinar, Akyol Duygu: *Contributions of Green Infrastructure-Oriented Planning and Designing in Residential Gardens to the City's Ecosystem: Case of Trabzon City, Turkey*. *Journal of Urban Planning and Development Vol. 149, Issue 1 (March 2023)*, 2023.
- [12] **The Concise Oxford Dictionary of Art Terms**, *Oxford University Press*, Published online: 2010.
- [13] Kabinet 505, Competition entry: **And tonight, I See Tomorrow**, Novi Sad, 2018 <http://kabinet505.ftn.uns.ac.rs/?p=1208>
- [14] Maas, Winy: **Metacity/Datatown**, *010 Publisher, Rotterdam* 1999
- [15] Aseel Hussien, Nusrat Jannat, Emad Mushtaha, Ahmed Al-Shammaa: **A holistic plan of flat roof to green-roof conversion: Towards a sustainable built environment**. *Ecological Engineering*, Volume 190, 2023.

## REUSE AND ENVIRONMENTAL IMPACTS OF TREATED DOMESTIC WASTEWATER

Muhammed Kamil ÖDEN<sup>1\*</sup>, Bilgehan Yabgu HORASAN<sup>2</sup>, Cemalettin SARIÇOBAN<sup>3</sup>, Ali ÖZDÖNER<sup>4</sup>

### Abstract

*This study investigates the results of the irrigation water use of the effluent of the Domestic Wastewater Treatment Plant in spring. Water samples for the study were taken from many different stations along the Sarayönü Wastewater Treatment Plant (WTP) located in Konya city. Physico-chemical parameters and major ions of the wastewater such as pH, temperature (T), electrical conductivity (EC), 5-days biochemical oxygen demand (BOD<sub>5</sub>), chemical oxygen demand (COD), total phosphorus, magnesium, and some compounds (sulphate (SO<sub>4</sub><sup>2-</sup>), ammonium (NH<sub>4</sub>-N), nitrate (NO<sub>3</sub><sup>-</sup>)) and trace metals were also measured to determine the overall irrigation quality of the exit wastewater. Further treatment of the treated effluent from the wastewater treatment plant was investigated whether it accumulates in the soil and agricultural products. Application has been made for electrocoagulation and adsorption treatment. After wastewater treatment, the effluent is used by farmers in the region as agricultural irrigation water. Analyzes were made to investigate the effect of this wastewater on soil and plants. In electrocoagulation treatment studies, more than 70% sulfate and magnesium removal was achieved. Nitrate and COD removal in the adsorption system was investigated. The use of smectite as an adsorbent has been investigated, but a desired level of purification has not been achieved.*

**Key words :** Sarayönü, Wastewater, Agriculture, Soil, Pollution

---

<sup>1</sup> Selcuk University, Sarayönü Vocational High School, Department of Environmental Protection Technologies, Konya, Türkiye, \* Corresponding Author : +90 332 617 2800, Fax: +90 332 617 3158, E-mail address: muhammedkoden@gmail.com

<sup>2</sup> Selcuk University, Sarayönü Vocational High School, Department of Environmental Protection Technologies, Konya, Türkiye

<sup>3</sup> Selcuk University, Agriculture Faculty, Food Engineering Department, Konya, 42049, Türkiye

<sup>4</sup> Selcuk University, Sarayönü Vocational High School, Department of Environmental Protection Technologies, Konya, Türkiye



## 1. INTRODUCTION

The rapid increase in the world population, the continuous development of the industry, and the inefficient use of water resources cause a rapid deterioration in surface water quality. This situation brings about an increase in water and food supply needs and causes water scarcity. This increasing pressure on water resources globally affects the water alternatives used in agriculture mainly [1,2].

Only 2.5% of the existing water resources around the world are freshwater resources [3]. And freshwater resources constitute 0.007% of the total water amount which is renewable and actually usable. While the rate of use of water resources in the world is 67% in the agricultural sector [4], this rate is around 74% in Turkey [5]. Surface water resources, which have the characteristics of a receiving environment, support many life forms, provide people with recreation and game fishing, as well as provide a good water source for drinking and use [6,7]. Heavy metal pollution in the aquatic environment has attracted constant attention and research in many branches of science because of the deterioration, bioaccumulation, bio-aggregation, and extensive biological toxicity that pose a risk to aquatic organisms, and most importantly, because it threatens human health [8]. The agricultural sector is one of the sectors in which water is used the most. Therefore, the use of treated wastewater is very popular with farmers. Since treated wastewater is rich in plant nutrients such as nitrogen and phosphorus, it reduces the need for fertilizers during agricultural use and increases the yield of the product received [9,10]. However, the heavy metal and persistent organic pollutants (PAH, PCB, etc.) content of wastewater limits the possibility of using treated wastewater in agricultural production due to its effects on the environment and animal health [11].

The World Health Organization has identified the main drivers for global wastewater reuse as closely related to its increase: a) water scarcity and stress, b) population and associated food safety issues, c) environmental pollution from inappropriate wastewater disposal, d) recognition of the resource value of wastewater and gray water [12]. The national legislation on wastewater reuse in our country is the "Water Pollution Control Regulation Technical Procedures Communiqué" published in the Official Gazette No. 20748 on 7 January 1991 for the first time. There are farmers who were unaware of the existence of this communiqué, which was put into effect for the controlled use of wastewater, especially in agricultural irrigation, long ago from many countries after it was subjected to adequate treatment [13]. The level of technology in the recovery of wastewater is directly proportional to the purposes of using the water to be recovered. If it is to be used in agricultural or green area irrigation, a good disinfection of the biological treatment outlet may be sufficient [10,14]. On the other hand, the quality and suitability of treated wastewater in terms of irrigation are also essential and should be evaluated. Even though it is treated efficiently in terms of physical and chemical pollutants, it should be used carefully in the agricultural field, especially since it contains many pathogenic microorganisms in domestic/urban wastewater [15].

## 2. MATERIAL METHOD

Sarayönü Biological Wastewater Treatment Plant is a wastewater treatment plant with a capacity of 3500 m<sup>3</sup>/day, which includes Physical, Biological Treatment, and

Sludge Dewatering processes. The facility, where state-of-the-art equipment is used, has been designed to perform Advanced Biological Treatment (Nitrogen-Phosphorus removal process) [16].

## 2.1. Characterization of Domestic Wastewater

Domestic wastewater treated at Sarayönü Biological Wastewater Treatment Plant is discharged. The regional farmer uses these treated waters given to the canal as irrigation water in dry seasons. The study was carried out on the analysis of soil and deposit samples taken in a controlled area. The plant material of the study was wheat variety. In addition, the purification of some pollutants in the adsorption and electrocoagulation processes of the wastewater samples taken from the plant effluent was studied in the laboratory environment. Since it is not possible to take two-hour composite samples from the treatment plant, the treated wastewater samples were taken from the treatment plant's exit during the discharge period. The samples taken into 2 L plastic containers for chemical analysis were labeled and brought to the laboratory and stored at +4 °C before analysis. Table 1 presents raw wastewater characterization.

Table 1 Characterization of Process Wastewater

Parameters	pH	Conductivity mS/cm	Temp. °C	COD mg/L	B mg/L	SO <sub>4</sub> <sup>-2</sup> Sülfat
Mean	5.46	26,8	18,8	22,7	0.263	115
Value	±0.2	±1.1	±0.5	±0.8	±0.1	±2.2
Parameters	Cr <sup>+6</sup> mg/L	Zn mg/L	NH <sub>4</sub> -N mg/L	NO <sub>3</sub> mg/L	Mg <sup>2+</sup> mg/L	Al mg/L
Mean	0.022	0.188	<5	19.1	54.4	0.009
Value	±0.01	±0.02	±0.06	±0.2	±0.5	±0.00 1

## 2.2. Experimental Studies and Procedure

Figure 1 shows the schematic representation of the laboratory scale system used in Electrocoagulation Process (EC). The diameter of the additional reactor made of plexiglass material is 9 cm and the height is 13 cm. The iron plate electrode pair was used in anode and cathode (6 cm width, 11.5 cm height and 0.1 cm thickness) and the distance between electrodes is 2 cm. Total active electrode area was determined as 80 cm<sup>2</sup>. Direct current to the reactor was achieved using the MERVESAN 305DI brand power supply.

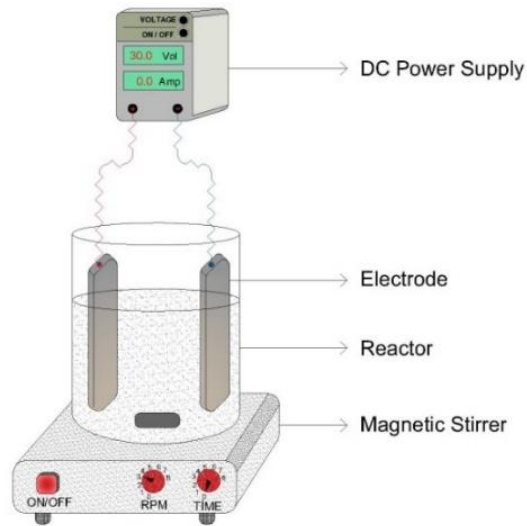


Figure 1 Schematic representation of EC process [17]

500 ml of raw wastewater was used in each test set. The effects of flow density ( $16\text{-}48\text{ mA/cm}^2$ ), reaction time (0-150 min) and pH (3-10) were optimized for EC process. After each experimental set, after several hours of settling period, purified samples were collected and analysed according to standard methods. Analysis of pollutants were performed in samples taken from the upper phases after precipitation [18-19].

### 3. RESULT DISCUSSION

According to the analysis results of the water samples taken from the Sarayönü Wastewater treatment plant, the pollutants such as COD, BOD<sub>5</sub>, AKM, Total-N, Nitrate, Sulphate, Magnesium, and Total-P are given in Table 1. During the laboratory study, electrocoagulation, adsorption, and soil/plant sample preparation processes were carried out in accordance with the relevant standard methods. In the electrocoagulation test process, criteria such as current density, time, pH, and mixing speed were taken into account. As pollutants, sulfate, and magnesium parameters were removed. In the adsorption experiment process, the study was carried out with the batch process. In the adsorption system, the removal of smectite as an adsorbent and the removal of COD and nitrate were studied. The yields obtained are shown in the graphs below.

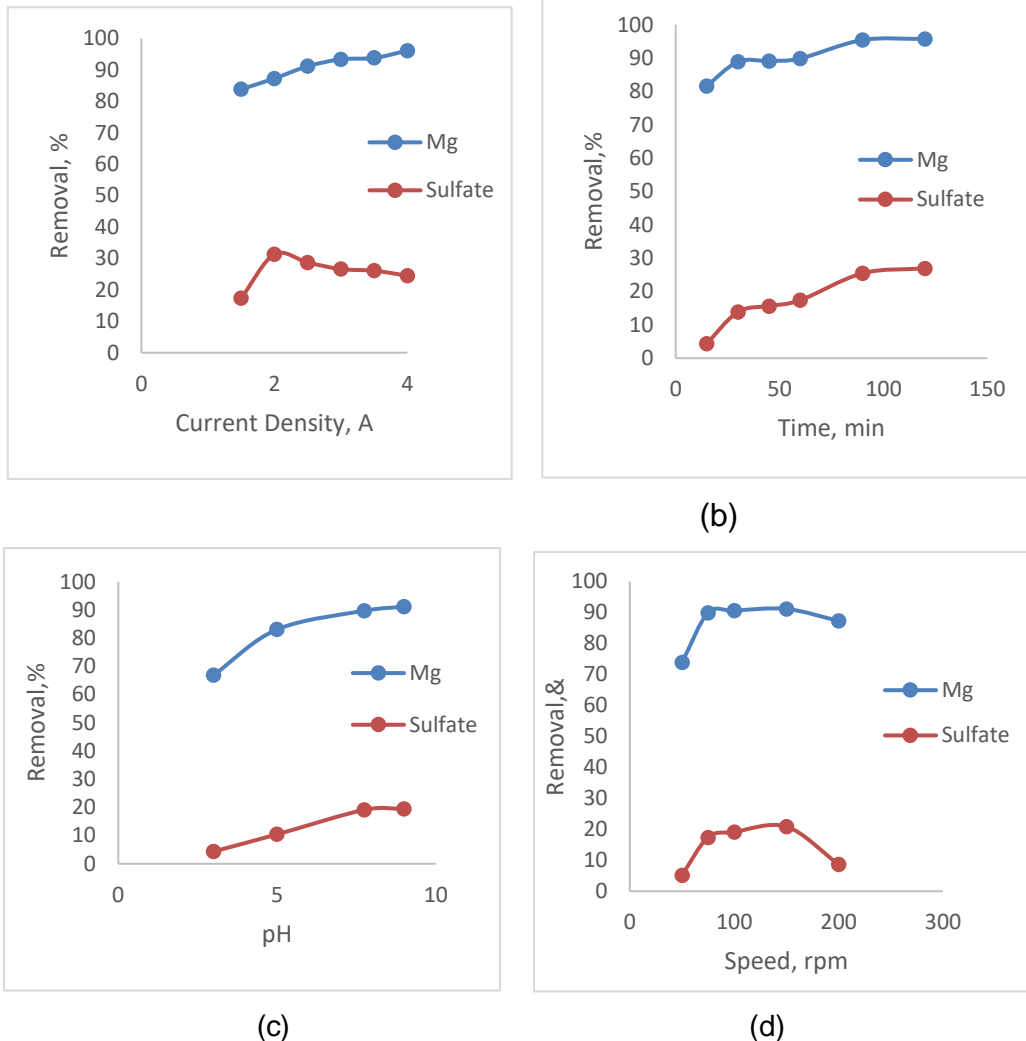


Figure 2. Electrocoagulation optimization studies a) current density, b) contact time, c) pH, d) mixing speed

#### 4. CONCLUSION

With the use of treated wastewater in the agricultural sector, which needs high amounts of water, effective and sustainable protection and use of water resources are ensured. If treated wastewater is used in irrigation, the compliance of the water with the limit values in terms of physical, chemical, and biological parameters should be considered.

While examining the usability of the treated wastewater as irrigation water, an evaluation alone is not sufficient in terms of compliance with the limit values in the legislation. At the same time, issues such as the soil properties where irrigation will be made, the crop pattern grown in the soil and the irrigation methods to be applied should also be taken into consideration. Before the final decision, laboratory studies and greenhouse trials should be conducted that allow to pre-evaluate the effects of treated wastewater on soil and vegetation. In this research study, a good efficiency

was obtained for electrocoagulation. However, high success was not achieved in the adsorption system.

## ACKNOWLEDGMENTS

This study was financially supported by Selcuk University Scientific Research Coordinating Office (Project Number: 22301005) in Türkiye.

## REFERENCES

- [1] Yaşar, A., & Doğan, E. C. Aritilmiş Kentsel Atıksuların Sulamada Kullanımında Mikrokirleticilerin Oluşturabileceği Riskler. Niğde Ömer Halisdemir Üniversitesi Mühendislik Bilimleri Dergisi, 9(2), 760-769.
- [2] Aydoğdu, M. H., & Kocaman, E. T. (2021). Eysel Atıksuların Tarımsal Sulamalarda Kullanılması Üzerine Bir Değerlendirme. Turan: Stratejik Araştırmalar Merkezi, 13(50), 108-114.
- [3] Yalılı Kılıç, M., Kestioğlu, K., Aydınalp, C., 2008. Atıksuların sulama suyu olarak kullanım olanaklarının değerlendirilmesi. Su Tüketimi Arıtma Yeniden Kullanım Sempozyumu, 3-5 Eylül, İznik, s. 355-366.
- [4] Adalı, S. & Yalılı Kılıç, M. (2020). Arıtılmış Atıksuların Tarımsal Sulamada Kullanımı: İznik Örneği . Uluslararası Biyosistem Mühendisliği Dergisi , 1 (1) , 12-23 .
- [5] Çakmak, B., Gökalp, Z., 2013. Kuraklık ve tarımsal su yönetimi. Gaziosmanpaşa Bilimsel Araştırma Dergisi, 4: 1-11.
- [6] Ikem, A., Egiebor, O. ve Nyavor, K. (2003) Trace elements in water, fish and sediment from Turkegee Lake, Southeastern USA, Water, Air and Soil Pollution, 149: 51-75,
- [7] Yetiş, A. D. & Özgüven, A. (2020). Van Gölü Edremit Kiyisi Yüzey Sularında Ağır Metal Kirliliğinin Araştırılması . Uludağ Üniversitesi Mühendislik Fakültesi Dergisi , 25 (2) , 831-848 .
- [8] Yetiş, A. (2019). Bitlis Ahlat Sazlıkları Yüzey Sularında Bazı Ağır Metal Düzeylerinin Araştırılması . Çukurova Üniversitesi Mühendislik-Mimarlık Fakültesi Dergisi , 34 (1) , 1-12 .
- [9] Büyükkamacı, N., 2009. Su yönetiminin etkin bileşeni: yeniden kullanım, İzmir Kent Sorunları Sempozyumu, 8-10 Ocak, İzmir, s. 363-377.
- [10] Demir, Ö., Yıldız, M., Sercan, Ü., Arzum, C.Ş. 2017. Atıksuların geri kazanılması ve yeniden kullanılması. Harran Üniversitesi Mühendislik Dergisi, 2(2): 1-14.
- [11] Aydın, M.E., Aydın, S., Bedük, F., Tekinay, A., 2015. Atıksuların sulamada kullanımı: toprak ve üründe kalıcı organik kirleticiler. Uludağ Üniversitesi Mühendislik Fakültesi Dergisi, 20(2): 99-110.
- [12] Pintilie, L., Torres, C.M., Teodosiu, C., Castells, F., "Urban wastewater reclamation for industrial reuse: An LCA case study", Journal of Cleaner Production, 2016, 139:1-14.
- [13] Deregümlü, D. Endüstriyel atık suların peyzaj mimarlığı uygulamalarında kullanılabilirliğinin araştırılması Süleyman Demirel Üniversitesi, (Master's thesis, Fen Bilimleri Enstitüsü), 2019.
- [14] Kurtkulak, H., Kentsel Atıksuların Geri Kazanımı ve Yeşil Alanların Sulanmasında Yeniden Kullanımı, Yüksek Lisans Tezi, Selçuk Üniversitesi, Fen Bilimleri Enstitüsü; 2014.

- [15] Can, S. & Dulkadirođlu, H. (2021). Arıtılmıř Atıksuların Tarımda Kullanımı ve İnsan Sađlıđı Yönünden Risk Deđerlendirmesi . Nevşehir Bilim ve Teknoloji Dergisi , 10 (2) , 124-134 .
- [16] Koski, 2023 - <http://www.cevre-yapi.com/product-detail/konya-sarayonu-beldesi-atiksu-aritma-tesisi/> (15.05.2023)
- [17] Oden, M. K., & Sari-Erkan, H. (2018). Treatment of metal plating wastewater using iron electrode by electrocoagulation process: Optimization and process performance. *Process Safety and Environmental Protection*, 119, 207-217.
- [18] AKKAYA, G. K., & ÖDEN, M. K. (2022). Optimization of the effect of copper electrodes on the removal efficiency of 4-chlorophenol from aqueous solution by electrocoagulation. *Environmental Research and Technology*, 5(1), 33-43.
- [19] Oden, M. K. (2020). Treatment of CNC industry wastewater by electrocoagulation technology: an application through response surface methodology. *International Journal of Environmental Analytical Chemistry*, 100(1), 1-19.

## ARCHITECTURAL FORM AND LIBRARY DESIGN

Nevena Pavlović<sup>1</sup>, Danica Stanković<sup>2</sup>

### Abstract

*In architecture, the form defines the principle by which the unity of the whole is achieved, but also determines the properties of the internal and external boundaries of the space. When we research the history of architecture, we are aware that the architectural space and consequently form went through physical and semantic transformation. In this paper, through the analysis of the form, spatial and functional organization, as well as the design characteristics of libraries, the specificity of this architectural type of buildings is pointed out. The goal of this research is to define the types of the possible spatial organizations in architectural design of modern libraries in the context of different influences, along with the derivation of common principles and conclusions related to their function and form.*

**Key words:** *form, architecture, design, library*

---

<sup>1</sup> MSc. Arch., Ph.D. student, University of Niš, Faculty of Civil Engineering and Architecture in Niš, nevena25696@gmail.com

<sup>2</sup> Ph.D., Associate Professor, University of Niš, Faculty of Civil Engineering and Architecture in Niš, danica.stankovic@gaf.ni.ac.rs

## 1. INTRODUCTION

The concepts regarding space and form are moved from one to the other in the course of history. Also, this change that space and form have undergone together should be considered based on the change and development in theory, discourse, technology, material, time etc. [1]

Adolf Behne claims that function is the consequence of individual need, and form is "the consequence of establishing a relationship between human beings". Architecture in its form is an expression of human identity and the human condition, a poetic expression of the human spirit. [2]

Yilmaz (1999) claims that form is also instrument for meaning or a sign. A part from that architectural form is also related to the elements themselves; arrangements, and combination with each other (syntax); the meaning (semiotix), and the affects on people (pragmatics). [3].

The subject of research in this paper is the theory of form as a key element in the process of creating an architectural object. The paper is based on the analysis of the form of libraries as an architectural typology and a comparative analysis of several derived libraries from around the world. The paper presents the development of form in design, as well as the shaping of libraries in the context of the immediate environment, the shape of the location, and the influence of functional organization. For the purpose of analysis, the paper presents examples of case studies of libraries from the perspective of design through reference implementations of objects.

## 2. METHODOLOGY

In order to examine the form of objects in contemporary libraries, as well as to investigate the main influential factors for the design concept, a comparative analysis of completed objects will be conducted.

For the purposes of this research, three contemporary libraries have been selected as subjects for in-depth analysis based on the following criteria:

1. The libraries were constructed in recent 10 years,
2. The libraries represent multifunctional centers that encompass a variety of cultural contents,
3. The objects have complex forms,
4. The locations of the libraries have irregular shapes.

The selected examples will be analyzed from the perspective of architectural form and materialization. In the analysis process, data collected from professional literature, design documentation, photographic documentation, and online sources have been used. The analysis will consider the relationship between the built structure and its immediate surroundings, architectural expression, materialization, and lighting. The primary goal of the applied methodology is to determine the main influential factors for the development of the design concept and how they impact the architectural design of library objects.

## 3. FORM IN ARCHITECTURE



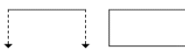

The word "form" originates from the Latin word and, in translation, it denotes shape, cut, appearance, pattern, model, figure, and more. Form represents a mode



of appearance. Ching states that form suggests the external contour, internal structure, and principle that gives unity to the whole. [4] Shaping an object, or its form, is one of the aspects that are first observed. Modernists claimed that form follows function, however, the shape of an architectural piece, its geometry, size, and arrangement of masses are not always a result of function.

Dinulović emphasizes the understanding of architectural form as a visible structure, configuration, or composition of elements. [5]

The basic elements of form are:

1. Point 
2. Line 
3. Surface 
4. Volume 

A point represents a position in space. By multiplying points together, a line is formed. It has its length as a dimension, but also possesses a certain direction and position. By multiplying lines, a surface is constructed. In addition to length and width, a surface has shape and a specific position. By further multiplication or establishing certain relationships, a volume is created. It is characterized by three dimensions. [6]

Primary elements such as points, lines, planes, basic shapes, and solid bodies have provided the foundation for various geometric forms as conceptual throughout history. We can also observe the utilization of these elements in architecture today. They are the fundamental elements that directly influence the formation of space and architectural form in any conceptual sense. In other words, these elements add aesthetic, symbolic, and conceptual richness to architectural design. For this reason, architects widely employ these elements, particularly in the organization of architectural space. [1]

#### 4. DESIGNING LIBRARIES IN THE CONTEXT OF DIFFERENT INFLUENCES

As the fundamental science of forms and their order geometry contributes to the process of composition and designing in architecture. Leopold observes that a composition in architecture starts with elements and their relations. Through history of geometry and architecture there were developed some rules based on geometry which formed the basis for architectural composition. [7]

Designing any object, including libraries themselves, involves considering various influences necessary to achieve a quality architectural piece. This includes the shape of the plot, the immediate surroundings of the location, and the form of the object, which also entails shape and materialization, both of which are of great importance. The form will largely depend on the shape of the location itself since objects often follow the dimensions of the plot and they certainly arise from a preliminary analysis of the location where they will be situated.

According to Last the first decades of the twentieth century saw the increasing theorization of the masses in terms of their spatial, aesthetic, and socio-political

implications. Over the past decade, as the world has increasingly become digitized, architecture's spatial imagery has increasingly aspired to a state of pure fluidity, acting as if in an opportunist fashion to take over a world of thought vacated. Along with spatial formations, fluid architectures are producers of spatial imagery that differ from their modern predecessors. [8] Against modernity's advancement of the spatial image of production as repetition, is the increasingly common appearance of fluid formations in the work of numerous architecture practices. [1]

#### 4.1. Parcel shape

The first phase in the library design process involves analyzing the location itself. Jovanović states that the size of the parcel, location characteristics, and available orientations will influence the designer's choices regarding the future building's features. [9] It is common practice to choose urban locations, locating the library in the central urban fabric at the heart of human activities, where well-organized traffic routes and public transportation with fast and comfortable means of transportation exist, and in proximity to users' workplaces and residences. [10] The shape of the parcel can be crucial in shaping the building itself. If it is a smaller or irregularly shaped parcel, the structure can be developed vertically.

In Figure 1 a), an example of a parcel with a regular geometric shape is shown. The library building entirely follows the shape of the parcel, resulting in a structure with a square footprint. Pedestrian access is provided from all sides, while vehicle access is available from the western side of the parcel. The ground level is utilized to enhance the space with various elements such as greenery, water features, seating areas, and the like. The building's shape harmonizes perfectly with its immediate surroundings.

In contrast to the mentioned example of a parcel with a regular shape, Figure 1 b) presents an example of an irregularly shaped parcel. We can conclude that the library building conforms to the form of the parcel in both two-dimensional and three-dimensional senses, resulting in a building with an irregular shape. Similar to the first example, the building's shape seamlessly integrates with its immediate surroundings.

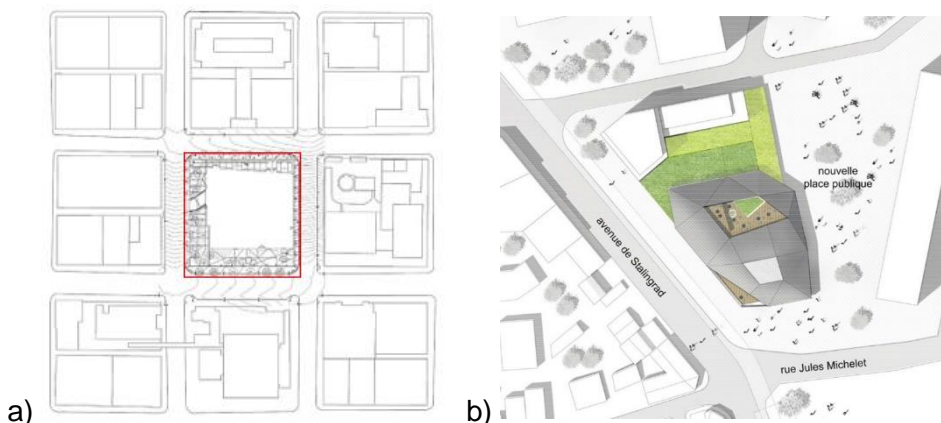


Figure 1. Media Library Colombes building (a) and Seattle Central Library building (b), [www.archdaily.com](http://www.archdaily.com)

#### 4.2. Immediate surroundings

The development of the design concept for contemporary public buildings, including library buildings, partly depends on the location and function, but to a great extent, it also depends on the site conditions. In this regard, the influence of the immediate surroundings is crucial for the design.

In Figure 2, an example of architectural design of a library that blends perfectly with its immediate surroundings is shown. The building's height follows that of neighboring structures. The subtle facade, in various shades of light color, gives the building a uniform and compact appearance. The materials used are in line with those of adjacent buildings. In order to ensure excellent integration of the library building with the neighboring structures while also achieving a modern look, the facade incorporates large glass surfaces.



Figure 2. North Beach Branch Library Building, San Francisco, LMS Architects  
[www.archdaily.com](http://www.archdaily.com)

#### 4.3. Functional organization

Each type of library, in its own unique way, requires a specific arrangement and grouping of rooms, and for that reason, they must be approached differently. Figure 3 shows the functional layout of a smaller library where the disposition of rooms on the ground floor is resolved in the best and most logical manner. [10]

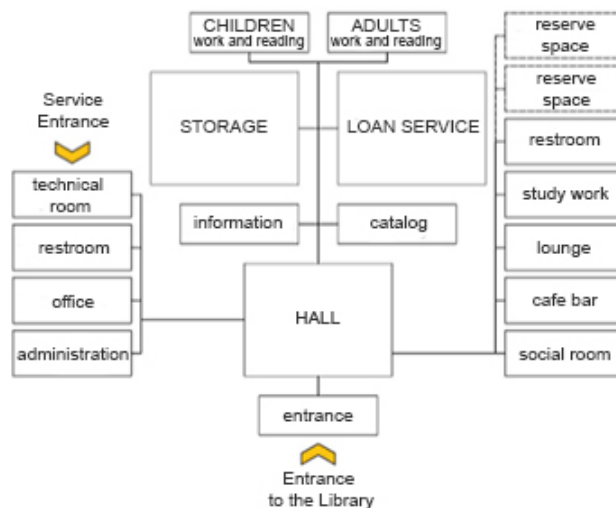


Figure 3. Functional Layout of a Small Library, Cekić Nikola: Projektovanje društvenih zgrada, Biblioteke, Građevinsko-arhitektonski fakultet, Niš, 1994

The fundamental principle in connecting the functional units of a library consists of very short, clear, and simple communication pathways in order to avoid wasting

time in work processes. Many implemented architectural solutions for libraries do not include corridors as strictly defined pathways but rather flexibly and organically integrate them within a monolithic surface. [10]

When it comes to large libraries, zoning is often done by floors. Reading rooms and lending sections are organized on the ground floor and upper floors, frequently divided into user groups per floor. For example, on one floor, there may be a lending department with spaces for reading and work dedicated to children of a specific age group, while on the next floor, there may be spaces intended for adults and so on. In addition to these traditional features, up to one-third of the library space should be allocated to additional social and cultural activities. [11]

#### 4.4. Materialization and Design

The shaping of an object, namely its form, is one of the aspects that is noticed first. The design concept of most contemporary libraries is such that they represent a fusion of the new and the old, a modern interpretation of traditional construction or materials. Glass is a mandatory material and sometimes serves as the primary architectural visual element in design. Such concepts completely blur the boundary between the exterior and interior spaces (Figure 4).

To achieve visual comfort and a pleasant atmosphere in each room, especially in public facilities such as libraries, attention must be paid to lighting technological solutions, both artificial and natural. It is recommended to make the most of high-quality daylight to meet the physiological and psychological needs of individuals in terms of safety and intellectual activities. [10]

The morphology of dimensions, the arrangement of furniture and equipment, the layout of horizontal and vertical communication, the placement of openings and walls according to the analyzed conditions in the interior, all need to serve the purpose of quality lighting (Figure 4). [10]



Figure 4. Design, materialization, and lighting of the library Springdale Library & Komagata Maru Park, Brampton, RDH Architects, [www.archdaily.com](http://www.archdaily.com)

## 5. CASE STUDY OF CONTEMPORARY LIBRARIES FROM THE PERSPECTIVE OF FORM AND MATERIALIZATION

In the following chapter, examples will be analyzed based on the prevalence of influential factors - plot shape, immediate surroundings, and functional organization. The mentioned examples from global practice are contemporary libraries whose concept primarily focuses on combining various functions and creating a multifunctional center. The conducted case study of libraries built in different periods demonstrates the diversity in terms of architectural form.

### 5.1. The Cloudscape of Haikou

The library named The Cloudscape of Haikou is located on the coast of Hainan Island in China. The serene location between land and sea was the main influential factor in the development of the design concept. The form of the building is highly sculptural. The free and organic shapes of the pavilions allow for the creation of unique interior spaces, where walls, floors, and ceilings merge in unpredictable ways, blurring the boundaries between the interior and exterior spaces. [12] The circular openings of the building resemble the holes carved by wild animals or the sea, further blurring the line between architecture and nature. Different sizes of openings allow for natural light to penetrate the interior and create a natural ventilation effect to cool the building in the warm climate throughout the year. The structural form creates several semi-open spaces and platforms, which also serve as excellent areas for reading and enjoying the view of the sea.



Figure 5. The Cloudscape of Haikou, MAD Architects [www.archdaily.com](http://www.archdaily.com)



Figure 6. Interior and Lighting of the Library The Cloudscape of Haikou, MAD Architects, [www.archdaily.com](http://www.archdaily.com)

### 5.2. Jiangxi College of Construction Complex

The building of the library-information complex, with a total area of 31,266 square meters, is a multifunctional complex that includes a library, classrooms, administrative offices, a restaurant, and other cultural and entertainment functions. The main influential factor for the development of the design concept was the functional organization and division into separate units according to their contents.

The shape of the building is irregular and complex. Five gaps are introduced in the north-south direction. Therefore, the building is divided into six strips, where different strips correspond to different functions (Figure 7). Different functional blocks

promote natural ventilation and lighting through the courtyard to avoid the use of air conditioning and achieve a low cost of passive environmental protection. [13]



Figure 7. Jiangxi College of Construction Complex, Nanchang, Architectural Design and Research Institute of SCUT, [www.archdaily.com](http://www.archdaily.com)

Concrete and large glass surfaces stand out as the applied materials. By using these two materials, a play of solid and void is introduced. The large glass surfaces are covered with concrete vertical slats of different dimensions, which can serve as protection against excessive sunlight for the building.

### 5.3. The Municipal Library of Vila Franca de Xira

Vila Franca de Xira City Library is located on the northern bank of the Tagus River, 15.5 kilometers away from Lisbon. The main influential factor for the development of the design concept was the specific location, and the functional organization was also a significant factor.

Taking into account the dimensions of the site and the appearance of the previous building, the architect immediately decided to build upwards. A tall structure would allow for the implementation of all planned programs while providing a perfect view of the surrounding landscape and the urban design of the city. [14]

The presence of a railway line between the city and the river represents a significant limitation for both the city and the library. To minimize this constraint, a metal structure was created, measuring 39 feet in height and 173 feet in length. This bridge starts in a small tower located on the city side and ends at the exterior level of the library's third floor. The bridge connects the city with the library itself and the coastal pedestrian path. The facade features a prominent triangular-shaped spacious window that is common to all floors, providing a visual representation of their contents from the outside. The architect employed triangular and trapezoidal forms, contrasting with the usual square and rectangular shapes. [14]



Figure 8. The Municipal Library of Vila Franca de Xira, Lisbon, Miguel Arruda Arquitectos Associados, [www.archdaily.com](http://www.archdaily.com)

## 6. DISCUSSION

By analyzing the selected examples, we can conclude that the design concept is influenced by multiple factors, with one key influential factor standing out. This often relates to the site itself, whether it is in terms of its shape (regular or irregular) or its immediate surroundings.

Regarding the first analyzed object, The Cloudscape of Haikou, we can see that the main influential factor is the immediate surroundings. Connecting nature and architecture was the primary motivation for the designer. Lighting all the elements was also crucial, and circular openings in the form of holes were chosen to establish a connection between the object and its immediate surroundings, the sea.

In contrast to the first example, the second analyzed object, Jiangxi College of Construction Complex, points to a different influential factor that was decisive in its design. It is the functional organization, specifically the idea of separating different content groupings into different blocks, which are connected through penetrations that allow excellent ventilation. Although both analyzed examples have irregular forms, completely different influential factors have led to different solutions and forms of the objects. Lighting and materialization were also important factors in line with contemporary trends.

The Vila Franca de Xira City Library, despite also having an irregular form, had the shape, position, and size of the site as the main influential factor in its design. The location itself demanded a solution where the building would develop vertically, with different contents arranged across different floors. The immediate surroundings also influenced the design, leading to the connection between the building and the tower on the city side through a metal bridge structure.

As a common feature among all the examples, we can identify an irregular shape of the site as well as the irregular form of the object itself. However, in each example,

we see a different dominant influential factor that has resulted in a completely different approach by the designers.

## 7. CONCLUSION

Architecture through form, function, and organization conveys a specific message and meaning, eliciting reactions from the observer. The message can be interpreted in various ways as a result of perception that changes under the influence of numerous factors. Communication with the observer is established through materials, function, color, and lighting.

When exploring the history of architecture, we are aware that architectural space, and consequently form, have undergone physical and semantic transformations. In the process of creating new architectural forms, there has been a departure from the former strict adherence to functionality and formalism, freeing itself from the laws of numbers and symmetry. This leads to the emergence of irregularly shaped objects that stand in contrast to their surroundings. There is a desire for unconventional forms and unexpected elements that are easily noticeable on the structures.

The presented work showcases objects that fully illustrate the diversity of architectural forms, as well as the main influential factors for the development of design concepts. Diversity is observed in the form of the building footprint itself. In addition to the variety in form, there is also diversity in the applied materials. However, through the analysis of selected library examples, we could see that all these forms primarily depend on specific influential factors related to the location itself, its shape or immediate surroundings, as well as the functional organization and lighting of the rooms.

## ACKNOWLEDGMENTS

This research has been realized with financial support from the Ministry of Science, Technological Development, and Innovation of the Republic of Serbia, under the agreement for the implementation and financing of scientific research of the Faculty of Civil Engineering and Architecture, University of Niš, in 2023. Registration number: 451-03-47/2023-01/200095.

## REFERENCES

- [1] Stanković Danica, Nikolić Vojislav, Kostić Aleksandra, Cvetanović Aleksandra: **Form in architecture and principles of design**, *Архитектура. Строительство. Образование*, No. 1, 57-63, 2018.
- [2] Hendrix John: Theorizing a contradiction between form and function in architecture, *SAJAH*, 27 (1), pp. 9-28, 2012.
- [3] Yilmaz Serkan: Evolution of the Architectural Form Based on the Geometrical Concepts, *Izmir Institute of Technology*, Izmir, 1999.
- [4] Ching, Francis D.K.: **Architecture: Form, Space and Order**, *John Wiley & Sons*, Hoboken New Jersey, 2007.
- [5] Dinulović Radivoje: **Ideoloska funkcija arhitekture u društvu spektakla**, *Međunarodna konferencija Arhitektura i Ideologija*, Beograd, 2012.



- [6] Wong Wucius: **Principles of Form and Design**, *John Wiley & Sons*, New Jersey, 1993.
- [7] Leopold Corneli: **Geometry concepts in architectural design**, *Proceeding of 12th International Conference on Geometry and Graphics*, Salvador, Brazil, August 6-10, 2006, Paper #T35, pp. 1-9, 2006.
- [8] Last Nana: **Architecture and the Image of Fluidity**, *Globalizing Architecture / Flows and Disruptions*, pp. 34-41, 2014.
- [9] Jovanović Goran: **Uvod u arhitektonsko projektovanje**, *AGM knjiga*, Beograd, 2015.
- [10] Cekić Nikola: **Projektovanje društvenih zgrada, Biblioteke**, *Građevinsko-arhitektonski fakultet*, Niš, 1994.
- [11] Jakovlevas-Mateckis Konstantinas, Kostinaitė Lina, Pupelienė Janina: **Conceptual Principles of the Planning of Modern Public Libraries**, *12th Seminar of the LIBER Architecture Group*, Italy, 2004.
- [12] <https://www.archdaily.com/960593/the-cloudscape-of-haikou-mad-architects> (29.08.2022.)
- [13] <https://www.archdaily.com/985513/jiangxi-college-of-construction-complex-architectural-design-and-research-institute-of-scut> (01.09.2022.)
- [14] <https://www.archdaily.com/626465/vila-franca-de-xira-municipal-library-miguel-arruda-arquitectos-associados> (01.09.2022.)

## CONTEMPORARY METHODOLOGY OF BANKING DESIGN

Đurđina Rančić<sup>1</sup>, Danica Stanković<sup>2</sup>

### Abstract

*Immediately before designing, it is necessary to become familiar with all the methodological aspects that help design the architectural space. Therefore, a good knowledge of methodology is necessary in all planning processes as well as during the construction of new physical structures. Analysis of the problem, creation of a solution and finally, the evaluation and selection of a solution are the stages that go through during every design process. Banks stand out as a particular type of administrative building. This research aims to look at modern approaches in the design of banks, which is realized as an analysis of content programs, functional analysis, and analysis of materialization and design. The paper aims to present the various possibilities of designing banks while providing adequate conditions of comfort and requirements defined by the purpose of the object and without disturbing the immediate environment.*

**Key words:** *principles of design, architecture, administrative buildings, bank*

---

<sup>1</sup> MSc. Arch., Ph.D. student, University of Nis, Faculty of Civil Engineering and Architecture in Nis, djinarancic996@gmail.com

<sup>2</sup> Ph.D., Associate Professor, University of Nis, Faculty of Civil Engineering and Architecture in Nis, danica.stankovic@gaf.ni.ac.rs

## 1. INTRODUCTION

Banks represent a specific type of administrative and business buildings that have evolved and developed in multiple phases, parallel to social and economic progress. Throughout history, they have been constructed in various ways, initially as integral parts of other houses or institutions, later as standalone structures, or even as entire districts within large cities. The modern era has brought new challenges in the methodology of designing, leading to the transformation of banks into facilities that are not only accessible to clients but also to other visitors.

Considering that "the modern age is rich in its variations of the understanding of space and time, especially regarding the buildings that emerge from it" [1], the construction of new, complex spaces is a rational result of this time. "Space is certainly not a new concept in architecture, but in contemporary literature, we distinguish two uses: space as three-dimensional geometry and space as a field of perception." [2].

The research subject in this paper is a contemporary approach to the design of public buildings, with a focus on banks. The paper is based on a comparative analysis of selected examples regarding their location, functional layout, form, and materialization. A methodology is presented, and the aim is to establish principles, as well as similarities and differences in the design process, through a comparative analysis of the selected examples.

## 2. THE HISTORICAL DEVELOPMENT OF BANKS

Although residential complexes and new cities are characteristic of contemporary architecture in the 21st century, buildings dedicated to administration and culture are undoubtedly important. Administrative and governmental buildings have a long history that has evolved over centuries up to the present day. Modern technology has replaced many things, allowing us to accomplish numerous administrative tasks from home. However, the level of security and reliability can only partially be replaced, no matter how advanced technology becomes.

The history of banking is closely connected to the emergence of money, where various forms of banking transactions preceded the invention of currency. This refers to bartering, the exchange of goods for goods. Houses, where goods were collected and stored for safekeeping, were called treasuries. The emergence of money is associated with the 7th century BCE and the region of Lydia in Anatolia, which was rich in gold and silver. It is assumed that money was not initially used as a medium of trade but rather as a more convenient way to store large quantities of precious metals in the form of coins. [3]

The existence of money quickly spread throughout the Mediterranean region. Each city had its own mint with symbols of rulers or deities (Figure 1). As a result, there arose a need to exchange money from one city for another, leading to the emergence of numerous activities related to money, known as safari (exchange) businesses. [3]

In the early 14th century, specialized financial institutions began to emerge, marking the second phase in the development of banking. Italian and Spanish banks came to the forefront during this period. The first bank is considered to be the Bank of St. George in Genoa (Casa di Sant Georgio), founded in 1407 (Figure 2). Banking

evolved through several stages, with the final phase closely resembling modern banking practices. Today's banks provide a wide range of services, but they essentially have two main tasks. The first is to accept individual deposits and safeguard their money until they need it again. The second task is to lend money to individuals who are willing to pay interest in return. [4]



Figure 1. Metal coins with the symbol of the Constantin the Great, [istorijskabiblioteka.com](http://istorijskabiblioteka.com)



Figure 2. The Bank of St. George in Genova, [istorijskabiblioteka.com](http://istorijskabiblioteka.com)

### 3. CONTEMPORARY TENDENCIES IN BANKING DESIGN

In order to continue the continuous development of modern banks and provide an attractive environment for existing and new users, the creation of functional and aesthetic modern spaces is increasingly sought. The modern era's architectural organisation implies space flexibility, a pleasant environment as well as the easy movement of both employees and clients.

The process of designing an object consists of making a large number of decisions that are interconnected. For this reason, decisions are grouped by phases, which are resolved in order, one by one, sometimes simultaneously and sometimes combined. All this represents the design methodology.

Sometimes the form of an architectural object is above the function; sometimes, the function dictates the form; sometimes, the form follows the form, but all explanations of the architectural solution are based on its function as a sign of imbalance. A sign is a spatial form, and meaning is the essence of architectural action.

#### 3.1. Location

Immediately before designing, he looks at the location itself, using maps and photos, but also on the spot. It is necessary to analyze the plot characteristics on which the bank's construction is planned. For quality design, it is necessary to collect as much information as possible regarding the environment's character, the construction plot's size and shape, possible access to the plot, etc. First, the broader environment is analyzed, then the narrower one, and the surrounding sights. The collected data affects the bank's position on the lot, and the organization of traffic, which nowadays plays a significant role, and in addition, it affects the determination of possible pedestrian access to the building itself.

The way to choose a location depends on several factors. Business, economic or cultural centres of urban agglomerations come into consideration. According to the size of the banks, they are built in a wide range, from heads and central banks to urban ones such as branches, branches, Etc. In larger cities and metropolises, several different banking institutions form the banking district in the very centre. It can be seen in Paris (slika 3), Tokio, New York (slika 4)... [5]



Figure 3. The bank district in Paris, frenchmoments.eu



Figure 4. The bank district in New York, corporatefinanceinstitute.com

As the use of motor vehicles increases, access roads and parking organizations must be taken care of. It is precisely for this reason that the so-called "drive-in" bank, where the problem of parking is solved to a great extent and the waiting time inside the facility is reduced. Such banks function because the client drives his car to the counter service and performs the intended transaction. The counter approached by car can be integral to the building or built as a traffic island. The counter service is likely located below the sidewalk level in the basement. In this case, the connection between the party and the officer is achieved using a pipe in which a microphone, a mirror and a cash machine are installed. [6]

### 3.2. The content program and functional organization

In order to responsibly meet the problems of different users in the design of public spaces, it is necessary to first take into account the basic dimensions of the human body. The contact between the user and the designed public space must ensure its comfortable, safe and effective use. [7]

Regarding the functional organization of banks, the premises can be divided into those intended for clients and those intended for employees or officials. The counter hall is intended for users and occupies the central and most important place in the building of every bank. After entering the building, first come across the vestibule, which is an integral part of every counter hall. There is a waiting room with seating, an area for cash machines, money shredding machines, Etc. One of the most demanding tasks when designing banks is designing the treasury. The main goal of every designer is to prevent it from breaking and breaking. Vault rooms must not border directly on neighbours' walls on the ground because burglars would otherwise drill a hole in the wall or dig a trench. The most suitable variant is for the vault to be

surrounded from all apartments, both above and below, rooms that are used daily. The path to the vault should be short and inconspicuous. At small banks, the client's vault, the safes and the bank's vault are located in one area, while at large banks, they are separated. [8]

After all, the group of rooms intended for employees also includes workplaces behind the counter. In addition to those mentioned, there are offices for working with parties, rest rooms for employees, archives, administration, meeting rooms, conference rooms, etc.

In order to get from the conceptual solution to the final project, the path is complex. It would help if you took care of the optimal disposition of the content, both horizontally and vertically, which will ensure smooth movement. The connection of content, in a way and the grouping of rooms intended for clients and employees, but also their communication as short as possible, is a required step.

The paper shows the functional scheme of a large bank (picture 5), where the layout of the rooms on the ground floor was solved in the best and most logical way. Large banks usually have a separate bank vault in addition to the vault for clients. There is a special administration and special security at its entrance. The connection is by staircase or elevator and is intended only for the connection with the vault, which is directly connected to the counter hall due to the shortest possible communication. [8]

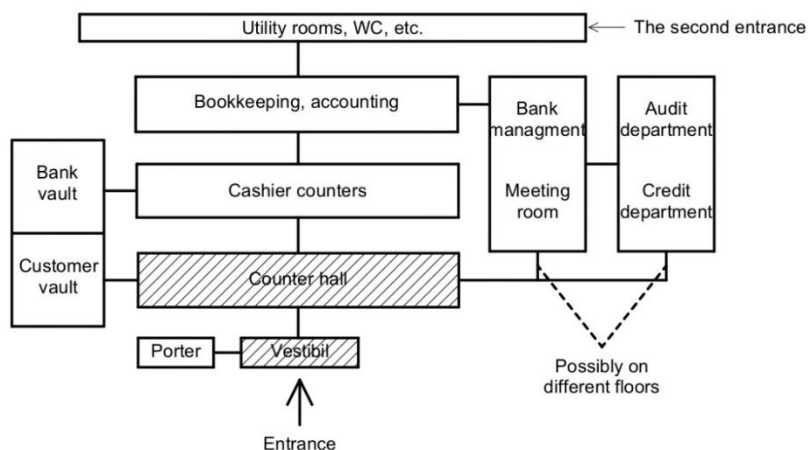


Figure 5. Typical architectural organization of a large bank, Nofjert E.: *Arhitektonsko projektovanje, Građevinka knjiga, Novi Sad, 2012.god*

### 3.3. Form and materialization

Banks, as a type of administrative-business building, represent objects of both architectural and artistic value. Integrating the bank into the immediate environment is an essential methodological approach to forming the exterior design. In terms of location, since the aim is to find an "attractive" place in the city, at the intersection of two busy streets or along the main street, the visualization of banks by highlighting their form and materialization is very significant. These are usually tall and slender buildings characterized by modern architecture. Emphasizing the exterior is done by combining different modern materials, different colours and adequate lighting. Facade details very often indicate the recognizability of the building.

By arranging the interior space, users and employees should be provided with a pleasant and comfortable stay. Constructive elements and staircases often become the main part of an interior expression, and sometimes all attention is directed to details in the form of equipment and furniture..

Regarding construction, some conditions must be met, and they concern the good coating of floors and walls to protect against noise, maintenance and the like. The main element of the bank, the vault, must be built of solid material and adequately isolated from the rest of the environment to prevent any burglary attempt. When it comes to multi-story buildings, the most common object of this type, the supporting structure, is a skeletal structure or a structure made of reinforced concrete.

#### **4. METHODOLOGY**

Designing architectural objects is a way to solve a design problem. It represents a series of activities related to defining and solving the problem. The designer uses various means and procedures, all aiming to provide the best possible conditions and comfort to people. The methodological approach to design is called Design Methodology, and the method is a procedure by which, based on knowledge of the problem, complete knowledge is obtained. [9]

The requirements that must be met when designing banks and responding to modern architectural expression require a good knowledge of the design methodology. In order to examine the characteristics of modern banks, as a selected case study, a comparative analysis of the constructed facilities will be performed.

In recent years, many banks have been built where the designers responded to contemporary architecture with functional solutions and design. For this research, considering the availability of project documentation, three examples of banks were singled out as the subject of detailed analysis. The selection was made based on the following criteria:

- The banks were built in the central city core;
- Banks have been built for the last 10 years;
- In addition to banking services, the bank's facilities also contain various services of a public nature, such as restaurants, gathering spaces, etc.;
- Banks have different physical structures.

The reference examples were selected based on the criteria mentioned above and will be analyzed from the aspect of the location, functional disposition of the content, architectural design and materialization. For the purposes of the research, professional literature and data from the Internet were used to collect data, project documentation, illustrations and photo displays. A detailed analysis of the collected material will deal with the relationship of the building with the immediate environment, the location of the building concerning the traffic infrastructure, the layout of the furniture intended for employees and clients, the application of materials and the architectural expression. This methodology should determine what similarities and differences we can recognize when designing banks regarding functional organization and design.

At the theoretical level, "established criteria for determining the interrelations of elements - the holders of multiple spatial contents - in the program terms, take multifunctional definitions by adding, overlapping or combining different spatial events and experiences" [10]. However, the way to combine content depends on the focus and primary purpose of the bank - some of them will be leading banks, others central banks, or urban ones such as branches, branches, etc.

In order to choose the appropriate method, essential knowledge of a specific type of object is necessary. In other words, a specific object can be successfully designed when the basic principles and requirements set by that type of object are mastered, that is, when its design methodology is known.

## 5. CASE STUDY OF SELECTED EXAMPLES

In this chapter, a detailed analysis of selected examples will be carried out according to the methodology of modern bank design regarding location, function and materialization. The examples are from different cities worldwide and were built in the past 10 years, which differ from each other according to predetermined criteria.

### 5.1. Bank „Shenzhen Rural Commercial Bank“, China

Shenzhen Rural Commercial Bank is located on the outskirts of the Chinese city of Shenzhen. The building, built in 2021, is the work of a global firm of architects called Skidmore, Owings & Merrill. This thirty-three-story building is 158 meters high and is located right next to a public park in the centre of the city's key business districts. The bank is located on the corner of two busy streets, near the main roads connecting Shenzhen with the surrounding cities, which is an excellent location for positioning the facility. [11]

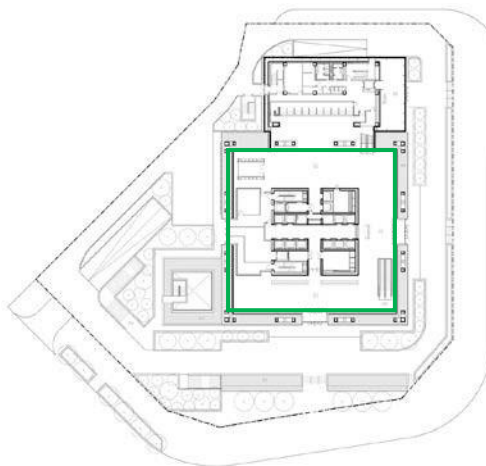


Figure 6. Plan of „Shenzhen Rural Commercial Bank“, <https://www.archdaily.com>



Figure 7. Sections of „Shenzhen Rural Commercial Bank“, <https://www.archdaily.com>



The form of the object, starting from the base, is compact and symmetrical. The base of the ground floor is rectangular, with an annexe in the northern part, while the other floors, starting from the first to the last floor, are square. The idea of the designers was a simple form of the object which would fit into the rest of the environment with its design. The functional organization is solved in a very logical and justified way. In the central part of the building, there are vertical communications and service rooms, while offices, meeting rooms, conferences, etc., are distributed around the perimeter. In this way, all areas of the building are sufficiently naturally lit. The supporting columns are arranged around the perimeter of the building, allowing maximum flexibility in the space.

The design inspiration came from natural systems and elements such as water or the water wall in the building's main lobby. In terms of modern architecture, the narrowly distributed rhomboid network aims to provide a solar shading system both on the building itself and on the interior spaces of the facility. The facade of the building is completely covered with glass over which the already mentioned rhomboid mesh of aluminium panels is placed.



Figure 8. „Shenzhen Rural Commercial Bank“, <https://www.archdaily.com>

## 5.2. Bank „Erste Bank Campus“, Austria

„Erste Bank Campus“, the new head office of Erste Group, which has become a natural sensation for both passers-by and employees, is located in Vienna. The building was built in 2015. This project was a competitive solution where a team of architects called Henke Schreieck Architects won. [12]

The complex is located in the city centre of Vienna; it relies on the main traffic network that leads to the city centre and connects to the highways of the surrounding cities. The solution is edge construction, where a pedestrian plateau is formed by cutting. The complex consists of a modern courtyard, bridges and staircases that provide an exceptional spacious experience, a variety of visual relations and the possibility of gathering since the outdoor area is open to the public. In this way, the revitalization and urbanization of the rotor were contributed to, and an architecture that is in context with nature was created.

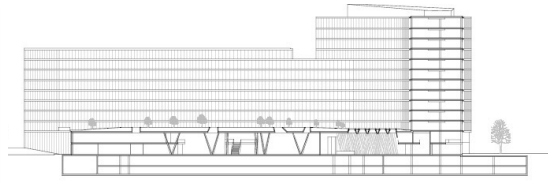
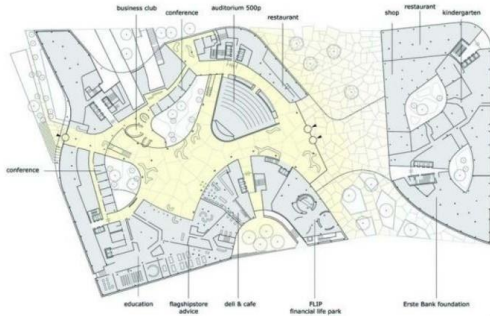


Figure 9. Landscape of „Erste Bank Campus“  
<https://www.arch2o.com>

Figure 10. Section of „Erste Bank Campus“,  
<https://www.arch2o.com>

As for the functional disposition of the contents, the office and work spaces are located next to the windows to get as much natural light as possible, but in this way, they are also provided with different views of the city. The base of the object is completely asymmetrical and freely shaped. It is a good example where you can clearly see the deviation from the rules, symmetry and modular design where freedom in design is achieved. The modern architectural organization of banks implies great space flexibility so that using mobile or folding walls can turn the space into extensive work or meeting rooms. Such flexible spaces enable direct contact, group or independent work.

The geometry of the individual building units, their proportionality, heights and positioning allow the campus and the urban space to flow into each other, where the interior and exterior merge. Therefore, "Erste Bank Campus" becomes an integral part of the city, and the city becomes a part of the campus. With its imposing design, the building fits perfectly into the landscaped garden. Large green areas, which align with sustainable architecture, further enrich the space.

The facade of the campus is entirely made of glass. The wavy shape makes the object elegant and modern. The roof garden, which in a way represents a bridge between the two tracts, is intended for employees.



Figure 11. „Erste Bank Campus“, <https://www.arch2o.com>

### 5.3. Bank „CDB & Minsheng“, China

„CDB & Minsheng Bank“ is located in the centre of Shenzhen, China. It was built in 2019 and designed by a team of architects called Zhubo Design. The location is in the administrative building district, at the corner of two main streets. Since the bank has two owners, the decision was made to build two connected buildings with a shared roof terrace above the second floor. [13]

The "edge ball", as the designers called it, is located at the corner of the plot, emphasizes the access to the building and also connects the two towers. It is a public passage that is entirely open to the city. It is taller in the central part to form a tall glass dome. In this way, the unhindered movement of both users and passers-by is enabled. The base of the building, with its orthogonal design, completely follows the shape of the plot.

The foundations of both buildings are almost regular orthogonal. The base of tower one (the tower on the left in the picture) is square. The base of tower two (the tower on the right in the picture) is rectangular. The designers used a modular arrangement of the construction, allowing great space flexibility and different contents' disposition. Vertical communications and auxiliary rooms are positioned in the central part of the base, while office spaces are arranged around the perimeter. Such an arrangement of rooms can be seen in both towers.

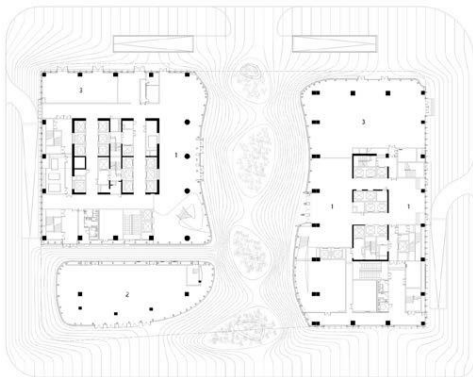


Figure 12. Plans of the groundfloors with landscape, [archidaily.com](http://archidaily.com)



Figure 13. Glass dome which connects two buildings, [archidaily.com](http://archidaily.com)

The use of glass dominates the entire height of the facades of both buildings. With their design and materialization, the buildings fit in entirely with other office buildings. The problem of overheating the interior space in the summer period was solved with the help of vertical blinds, where the vertical elements are twisted at 45 degrees to the top of the tower building and at the corners that receive the most solar radiation. The use of glass connects the interior of the building with the rest of the city. The building is a combination of architecture and space flexibility, the harmonious composition minimally disturbs the environment, and the visualization is reflected in the details of the simple shape of the building.



Figure 14. „CDB & Minsheng Bank“, archidaily.com

## 6. DISCUSSION

Table 1 gives a tabular presentation of the analyzed banks, considering the aspect of the location, functional organization, form and materialization. Based on the analysis, the similarities and differences of the selected examples can be concluded, as well as how the location affects the content's functional disposition and the object's shape.

Table 1. Comparative analysis of examples

	„Shenzhen Rural Commercial Bank“	„Erste Bank Campus“	„CDB & Minsheng Bank“
<b>Location</b>			
Surroundings	Bussines zone	Residential bussines zone	Bussines zone
The pozition in relation to the city	The periphery of the city	City center	City center
<b>Funcion</b>			
Number of floors	Multi-story building	Multi-story building	Multi-story building
The funcional organization of the floor plan	Typical	Typical	Typical
The funcional organizacion of content	By floors	By floors	By floors
<b>Form and materializacion</b>			
Type of building	Individual building	Pavilion	Pavilion
Type of form	Simple cube, verticality	Curved shape	Simple cube, verticality
Materialization	Glass	Glass	Glass

The obtained results indicate certain similarities among the analyzed examples. All banks are built in business areas in the narrow or broader city centre. Therefore, the most favourable location for constructing a large bank is a busy part of the city, at the intersection of busy roads. In a two-dimensional sense, the functional

organization of space is typical, which means that office spaces are grouped around centrally placed, vertical communications. The division of content, in all examples, was done by floors.

When it comes to the shape of the banks, they are characterized by pronounced verticality, and it can be seen that the objects range from simple to asymmetric curvilinear cubes. The extensive use of glass and simple exterior materialization is the same for all of them. This use of materials indicates the problematic fusion of the object with the immediate environment. At the same time, the use of larger glass surfaces allows for a pleasant ambience inside the space and the creation of suitable views from the interior.

## **7. CONCLUSION**

When it comes to the design of public buildings such as banks, which belong to administrative-business buildings, function plays an important role. For this reason, it is necessary to consider users' needs and enable them to move as unhindered as possible. Also, the arrangement of functional units should be coordinated and connected, which is an essential method during design. The object's shape, size and geometry are not always a direct consequence of the function because, in architectural creativity, there is always a component of aesthetic organization. An important parameter of any object is undoubtedly the construction. It should be remembered that the structure is sometimes hidden and sometimes dominant in the architecture. When it comes to the materials from which the building is built, especially those we notice first, they significantly affect the overall quality of the architecture.

Visualization of the bank is only one way to attract the attention of future users. To gain a competitive advantage, in addition to investing in the look and shape of the building, one must also invest in developing their services and creating adequate strategies for attracting new and retaining existing clients. With this type of facility, the trust and security of the clients are essential because, as already mentioned, they entrust the bank with their money, papers or valuables, take out loans, etc.

In recent years, when we are increasingly faced with a lack of time and the advancement of technology that allows a large part of administrative services to be performed over the Internet, the question remains how will architecture contribute to the survival of banks. In broad conclusion, a detailed study of the needs of future space users and a suitable design methodology can achieve comfort and satisfaction.

## **ACKNOWLEDGEMENT**

This research has been realized with financial support from the Ministry of Science, Technological Development, and Innovation of the Republic of Serbia, under the agreement for the implementation and financing of scientific research of the Faculty of Civil Engineering and Architecture, University of Niš, in 2023. Registration number: 451-03-47/2023-01/200095.

## REFERENCES

- [1] Mathew Praveen, Dani Jose, Donna Rajan, Jitha K.R, Treesa Varghese M.: **Funcional Planning of An Administrative Building**. *International Journal of Engineering Research & Technology*, Vol. 4, 2015.
- [2] Cekić N.: **Teorija arhitektonske forme**. *GAF Niš, Predavanja za doktorske studije*, 2009.
- [3] Šehović D.: **Pojava i razvoj bankarstva**. *Naučna knjiga*, Podgorica, Vol. 50, 2021
- [4] Đukić Đ., Bjelica V., Ristić Ž.: **Bankarstvo**. *Naučna knjiga*, Beograd, 2013.
- [5] Putnik N.: **Autobuske i autostanice**. *Naučna knjiga*, Beograd, 2007.
- [6] Stanković D.: **Projektovanje javnih zgrada**. *GAF Niš, predavanja iz predmeta javne zgrade*, 2017.
- [7] Watson D., Crosbie J. M., Callender J. H.: **Time-Saver Standards for Building Types**, seventh edion. *McGraw Hill*, 2022.
- [8] Nojfert E.: **Arhitektonsko projektovanje**. *Građevinska knjiga*, Novi Sad, 2012.
- [9] Miljević M.: **Metodologija naučnog rada**. *Filozofski fakultet, Univerzitet u Istočnom Sarajevu*, 2007.
- [10] Bonnanda, S. & Donahue, T.: **What's in a name? The evolving librarycommons concept**. *College and Undergraduate Libraries*, Vol. 17, 2010.
- [11] Shenzhen Rural Commercial Bank Headquarters / Skidmore, Owings & Merrill | ArchDaily (05.01.2023.)
- [12] <https://www.arch2o.com/erste-campus-headquarters-henke-schreieck-architekten/> (05.01.2023.)
- [13] <https://www.theplan.it/eng/award-2021-officebusiness/retreating-in-order-to-advance-cdb-bank-minsheng-bank-financial-building-zhubo-design-co-ltd> (05.01.2023.)

# STUDIES ON THE IMPACT OF WASTE FOUNDRY SAND ON THE PROPERTIES OF CEMENT COMPOSITES FOR ENVIRONMENT CONCERNS IN OMAN

Rathan Raj Rajendran<sup>1</sup>, Ali Said Ahmed Matraf Almanjawi<sup>2</sup>

## Abstract

*Solid waste disposal is a big environmental issue that poses serious risks to our planet. Reusing and properly disposing of these materials is crucial. As many industries' by-products and waste products continue to grow, solid waste management has emerged as a pressing global issue. According to Oman's 2040 sustainability vision, solid waste management is a primary priority. Using these elements in cement composites and concrete not only helps to keep costs down but also lessens waste management worries. Waste foundry sand (WFS) is an example of an unwanted industrial by-product. The manufacturing of ferrous and nonferrous metal castings generates a by-product known as waste foundry sand. Foundry sand's physical and chemical qualities are influenced by the casting techniques and industries used. In a foundry, the sand is recycled and reused several times. Waste foundry sand is sand that has been taken from a foundry after reaching the point where it can no longer be utilized. Numerous research and published findings indicate that replacing fine aggregate with WFS improves the durability and mechanical strength of concrete. Additionally, concrete made with WFS as a partial replacement for fine aggregate is strong, lightweight, and long-lasting. This experimental work aims to study the impact of waste foundry sand on cement mortar properties by replacing it with fine aggregate up to 40%. Various tests were carried out to study the material properties, strength, and shrinkage properties of cement mortar. According to the research findings, replacing foundry sand improves the cement's strength and shrinkage qualities to a certain amount, while simultaneously lowering slump values as replacement levels of waste foundry sand increase.*

**Key words:** *Waste Foundry Sand, Cement Composites, Strength, Shrinkage*

---

<sup>1</sup> Dr, Senior Lecturer, Civil and Architectural Engineering Section, Department of Engineering, University of Technology and Applied Sciences-Salalah, Sultanate of Oman, r.raj@sct.edu.om.

<sup>2</sup> Mr, Teaching Assistant, Civil and Architectural Engineering Section, Department of Engineering, University of Technology and Applied Sciences-Salalah, Sultanate of Oman.

## 1. INTRODUCTION

The manufacturing of ferrous and non-ferrous metal castings generates foundry sand, which is a high-quality silica sand. According to Bhardwaj and Kumar [1], this silica sand is of the highest quality, has a high standard, and is utilized in the casting and molding processes at foundries. Molding sands undergo multiple rounds of reuse and recycling during the casting process, according to Siddique [2]. He also said that waste foundry sand is what happens to reclaimed sand when its quality degrades to the point that it can no longer be used for casting and must be disposed of (WFS). The type of casting method used and the industry it is used in have an effect on the physical and chemical characteristics of foundry sand.

Ferrous metals include cast iron and steel, whereas non-ferrous metals include aluminum, copper, brass, and bronze. Multiple materials can be molded in a single operation, allowing for the creation of components with simple or intricate architectures. Because of its low cost, excellent durability, high-temperature tolerance, and ability to bond with various binders and organic compounds, WFS is a common molding sand used in foundry manufacturing. Compared to normal sand, this material is superior for trash recycling. As a result, scholars and scientists from all around the world are collaborating to develop novel approaches to reduce or recycle these wastes. Due to the efficient exploitation of industrial waste materials, issues regarding their disposal can be reduced. The process of substituting alternative components in concrete, which has been shown to boost mechanical and durability properties, enables sustainable concrete development. To properly comprehend the potential of waste foundry sand (WFS) as a replacement for fine-aggregate concrete, it must be thoroughly investigated.

According to Singh and Siddique's [3] description in their study, foundry waste sand consists of burned silica sand, dust, bentonite, and sea charcoal. Clay bound sand, also referred to as "green sand," is frequently used to create molds and consists of silica sand (80–95%), bentonite clay (4–10%), a carbonaceous additive (2–10%), and water (2–5%). Approximately 85 to 95 percent of the particles in the foundry sand have mesh sizes between 0.6 and 0.15 millimeters, indicating a relatively uniform particle size distribution. According to Siddique & Noumowe [4], between 5 and 12 percent of foundry sand will be smaller than 0.075 millimeters. This study summarizes and analyzes the results of experiments conducted on concrete characteristics such as specific gravity, bulk density, grain size analysis, consistency and setting time, cement fineness, drying shrinkage, and compressive strength in relation to WFS.

## 2. LITERATURE REVIEW

The use of foundry sand, which is high-quality silica sand with consistent physical characteristics and a physical structure, has been studied by several researchers. Tara Sen and Umesh Mishra [5] reported the use of WFS in village road construction. According to Evaggelia and Scott [6], the addition of WFS as a filler to face bricks at low replacement rates (primary sand substitution at 2.5% and 5%) was effective. Alberta and Kevin [7] explored the use of industrial by-products in urban roadway infrastructure. Kae-Long Lin et al [8] highlighted recycled WFS as a raw material for cement additives.



Khatib et al [9] studied the mechanical and fresh properties of concrete made from foundry sand waste. When the content of foundry sand increases, the examined parameters exhibit a systematic decrease in workability, according to their findings. In addition to noting that all of the mixtures, both with and without WFS, exhibit an increase in strength with curing time, this was determined by calculating the percentage reduction in a slump with increasing WFS. The compressive strength of concrete increases as WFS concentrations increase. This degradation was expected. Additionally, the control mix exhibits the least degree of water absorption, and both shrinkage and water absorption normally increase proportionally with concrete's water-fixing strength (WFS). Singh and Siddique [10] conducted experiments to test the durability and strength of concrete mixtures in which a portion of natural sand was substituted with synthetic sand (WFS). The results of their testing showed that WFS-containing concrete mixtures had compressive strengths that were higher than those of control concrete. A study of 28 and 91 days of compressive strength reveals that the percentage increase in compressive strength declines with the rise in WFS concentration, decreasing from 7% to 1.98%. As the WFS component increased, the splitting tensile strength of concrete mixtures increased. A greater splitting tensile strength was recorded at 15% WFS.

Saveria Monosi et al [11] examined the characteristics of mortars and concretes with various dosages of used foundry sand (UFS) as a partial sand replacement in both fresh and hardened conditions. UFS lowers workability when used as a natural sand replacement (at the same w/c); an additional superplasticizer is required to retain the same workability. Compared to mortars containing UFS, the control mortar sample with a w/c of 0.50 required an increase of up to 1.8% by weight of cement. The same holds true for UFS-containing concrete mixtures that require a superplasticizer dose. Despite the absolute value of compressive strength, a lower w/c tends to amplify the negative effect of UFS on compressive strength loss. As is typical, the compressive strength has a high absolute value for low w/c ratios but only modest benefits when w/c is below 0.50. Martins et al [12] conducted research on waste foundry exhaust sand (WFES) and published the study's findings on its use as a partial replacement for fine aggregates in conventional concrete. Depending on the physical qualities and chemical composition of WFS, various WFS percentage effects on the mechanical properties of CMWFS can be observed. The increase can be attributed to the fact that WFS has a high concentration of calcium-silica-hydrate gel, or C-S-H, which improves concrete bonding and densification and is finer than the typical fine aggregate. Iqbal et al [13] examined how to estimate the mechanical parameters of green concrete with used foundry sand. They stated that it is widely understood that the w/c ratio has a substantial impact on the characteristics of concrete. When the w/c ratio increases and vice versa, the  $f_c$ ,  $E_c$ , and  $f_{st}$  drop.

### **3. EXPERIMENTAL STUDY**

To assess the effects of waste foundry sand on the physical and mechanical properties of concrete, an experimental program was developed. The examination is separated into two sections. The first phase examines cement's qualities, while the second examines concrete's mechanical properties. This paper deals with the

investigative results of phase one. The waste foundry sand was obtained from Dunes Oman LLC.

### 3.1. Materials and mix proportions

Ordinary Portland cement (43 Grade) procured from the Rysut cement factory in accordance with BS EN 197-1:2011 42.5N / OS-7/2001 was used in this study as a binding material. The consistency of cement was conducted as per ASTM C-187 and found as 31%. Locally available fine aggregate (FA) and coarse aggregate (CA) were used. The bulk density and percentage of voids of fine and coarse aggregate and waste foundry sand were found as per ASTM C-29. The specific gravity was found as per ASTM C 127/128. The properties of fine and coarse aggregate are listed in Table 1. The fineness modulus of fine aggregate, waste foundry sand, and coarse aggregate were found as 4.33, 2.89, and 4.16.

Table 1. Physical Properties of Aggregates

Property	Fine Aggregate	Waste Foundry Sand	Coarse Aggregate
Specific Gravity	2.64	2.31	2.67
Apparent Specific Gravity	-	-	2.69
Bulk Density (kg/L)	1611.68	1330.20	1481.82
Percentage of Voids (%)	38.85	42.44	44.56
Fineness Modulus	4.33	2.89	4.16
Water absorption (%)	-	-	0.32

The sieve analysis test adhered to ASTM C-136 standards. To assess the pattern of particle size distribution, sieve analysis was performed on discarded foundry sand and fine aggregate. WFS is a finer substance than FA, according to a sieve analysis comparison of WFS and common sand. Table 2 displays the results of the sieve analysis, and Figure 1 depicts the CA, FA, and WFS sieve analysis patterns.

Table 2. Sieve Analysis Results of CA, FA, and WFS

Coarse Aggregate		Fine Aggregate		Waste Foundry Sand	
Sieve Size	% Passing	Sieve Size	% Passing	Sieve Size	% Passing
37.5	100	5	99.12	5	99.61
20	95.73	3.35	91.99	3.35	99.22
14	50.99	2.36	81.97	2.36	98.33
10	26.55	1	62.72	1	97.11
5	5.37	0.600	55.89	0.600	95.94
3.35	2	0.425	52.03	0.425	70.43
Pan	0	0.300	48.22	0.300	46.43
		0.150	39.17	0.150	36.05
		0.075	34.81	0.075	34.89
		Pan	33.36	Pan	3.44

In phase one of the investigation, cement mortar was made according to ASTM C-109. Utilized mortar is composed of one part cement and 2.75 parts sand, in mass

proportions. The cement is mixed at a water-to-cement ratio of 0.48, which was established based on consistency. Five mix proportions were created, and cement mortar was also prepared. Four of the five combinations were generated by substituting 10%, 20%, 30%, and 40% of fine aggregates with waste foundry sand, whereas the fifth mixture was a control mixture (CM) containing no WFS. Table 3 are listed the proportional formulations of five mixes.

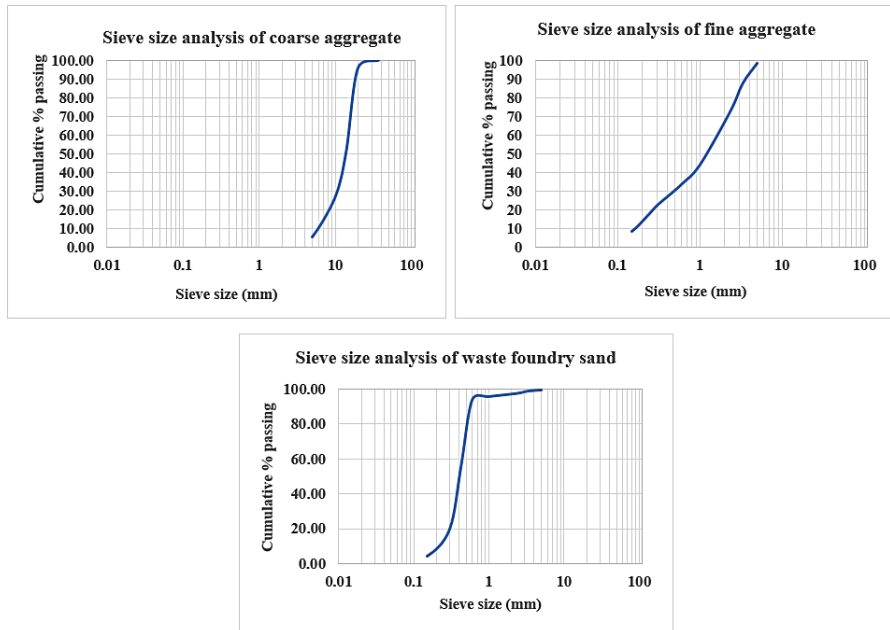


Figure 1. Sieve Analysis pattern of CA, FA, and WFS

Table 3. Different mortar mixtures Proportions

Mixture	Control mix	10% WFS	20% WFS	30% WFS	40%WFS
Cement (gm)	2000	2000	2000	2000	2000
FA (gm)	5500	4950	4400	3850	3300
WFS (gm)	-	550	1100	1650	2200
Water (ml)	968	968	968	968	968

### 3.2. Specimen preparation

Compositions of cement mortar were formulated with and without WFS replacement. The WFS replacement rate ranged from 10% to 40% in 10% increments. To determine the compressive strength of cement, a cube measuring 70.7 x 70.7 x 70.7 mm was created. Each cube specimen was filled with cement mortar, and a table vibrator was used to compact it. After each specimen was cast, it was covered with a plastic sheet to prevent moisture loss. After 24 hours at room temperature, samples were demolded and placed in the curing tank until test dates. In compression testing equipment, the cubes were subjected to compression tests at ages 1, 3, 7, and 28 days after the required curing period. Each day, three test cubes were cast.

The method of evaluating whether the elongation of set cement mortar is due to drying shrinkage or elongation is known as drying shrinkage or elongation

determination. For this aim, laboratory-made samples of hardened cement mortar that have been subjected to controlled temperature and humidity conditions are utilized. For all test combinations, a water-to-cement ratio of 0.4855 is used, and WFS is used to calculate cement replacement percentages of 0%, 10%, 20%, 30%, and 40%. To obtain a homogenous composition, all ingredients are weighed and well combined. As the mortar test specimen, a 285 mm long prism with a 25 mm square cross-section will be utilized. Immediately upon mixing, the mortar is poured into a 25 x 25 x 285 mm mold and crushed using vibration equipment. After 24 hours of demolding, the drying shrinkage of cement mortar is measured. The item was then immersed in lime-saturated water storage per Specification. After seven days of curing, each specimen's length comparator reading was recorded. The specimens were then placed in a drying room where the relative humidity was maintained at  $50 \pm 4\%$  and the temperature was maintained at  $23 \pm 2$  °C. According to ASTM C-157, the prisms were tested at the conclusion of each of the 7, 14, 21, 28, and 35 days of storage. Calculate the length change of any specimen at any age after the initial comparator reading by using the following formula:

$$\Delta L_x \frac{CRD - initial}{G} \times 100 \quad (1)$$

Where:

$\Delta L_x$  = length change of specimen at any age, %,

CRD = difference between the comparator reading of the specimen and the reference bar at any age

G = the gage length

## 4. RESULTS AND DISCUSSIONS

### 4.1. Compressive Strength of Cement Mortar

Results of the mortar's compressive strength after various curing days are shown in Table 4. Additionally, Figure 2 & 3 depicts the variance in mortar strength for various replacement percentages of WFS and curing days. In comparison to the control mix, the cement mortar strength containing WFS<sub>10</sub> demonstrated greater strength at all replacement levels. When WFS is increased from 0% to 10%, the compressive strength increases by 6.4% in comparison to the control mix.

Mortar's compressive strength was decreased while the remaining % of replacement was replaced. The densification of the paste structure brought on by the WFS's fine particle size is what is responsible for the increase in strength that results from the replacement of sand with WFS. For each percentage replacement level of WFS, it is found that the compressive strength of cement mortar has increased during all curing days. The fact that 95% or more of the sieved material passes through a size of 600 microns or more shows that WFS contains more fine particles. As a result, the presence of more fine particles increased their surface area, which in turn decreased the need for water. This is why the WFS did not increase in strength above 10% replacement.

Table: 4 Compressive Strength of Cement Mortar for various days of Curing

Replacement in %	Compressive Strength (N/mm <sup>2</sup> )			
	Day 1	Day 3	Day 7	Day 28
0	12	23.4	28.7	34.1
10	11	29.3	28.6	36.3
20	11.2	21.8	25	24.8
30	3.5	14.2	16.5	22.7
40	5.8	12.7	16.4	23.8

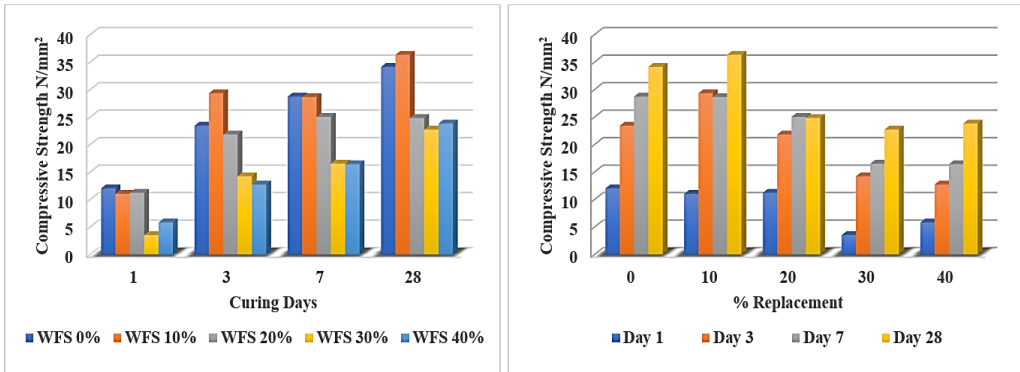


Figure 2. Variation of Compressive strength for different curing days and % replacement

#### 4.2. Drying Shrinkage of Cement Mortar

Being essential, drying shrinkage is the contraction of a hardened mortar mixture caused by the loss of capillary water, similar to how cement hydrates. This is a frequent phenomenon that impacts the durability of all Portland cement mortar and concrete as they age, making it a very significant element that cannot be ignored. It was observed that systematic increase in shrinkage of mortar as compared to the control mix as the level of sand replacement with WFS increased. The measured gauge length of the prism specimen of different percentage replacements of WFS is given in Table 5. Table 6 shows the drying shrinkage value of cement mortar for different percentage replacements of WFS.

The drying shrinkage of the control mix was found to be 1.085 on day 7, expanding by 0.0152 mm from day 1 and continuing to expand by 0.0188 mm on day 14. On day 21, the change in length was found to be 0.0224 mm, and on day 28 it was found to be 0.0232 mm. On day 35, it begins to shrink, and the length decreases by 0.0188 mm from day 1. The drying shrinkage of mortar with 10% replacement of WFS was found to be 3.430 in day 7 and expanded in day 14 by 0.00204 mm. In day 21, the change in length was found to be 0.024 mm, and in day 28, it was found to be 0.0248 mm. In day 35, it started to shrink, and the length of the prism shrank by 0.0132 mm from day 1.

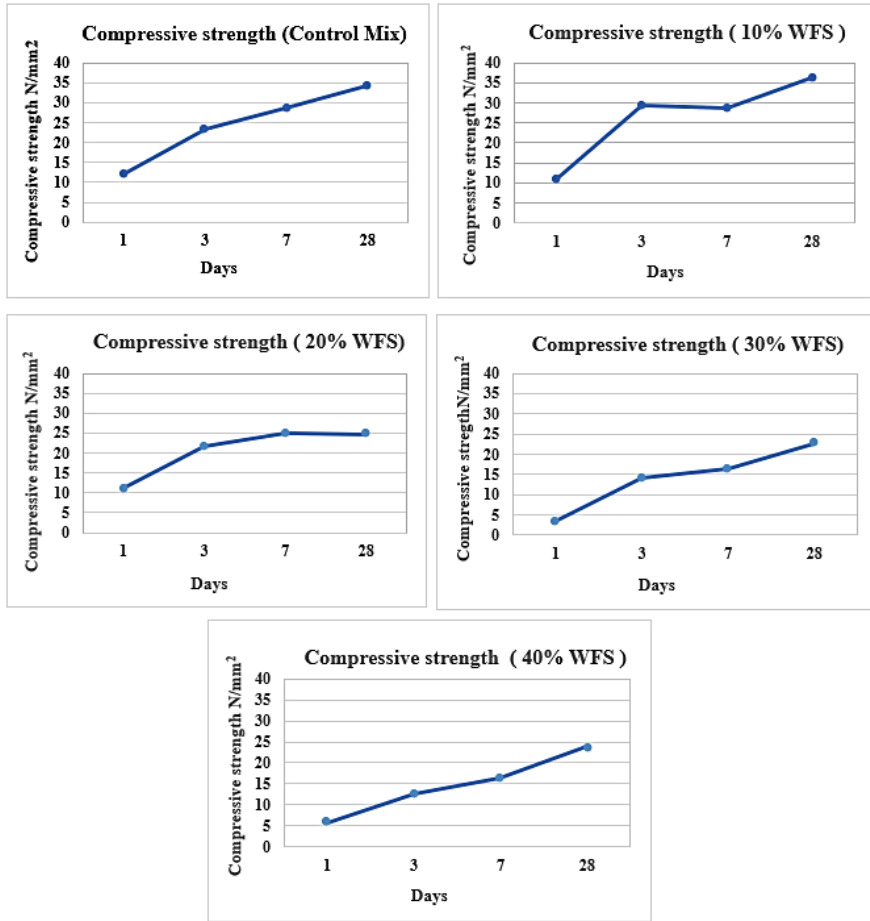


Figure 3. Variation of compressive strength for different replacement percentages of WFS

Table 5. Measured gage length of prism specimen for different percentage replacement of WFS

Days on Test	Gage Length				
	Control Mix	10% WFS	20% WFS	30% WFS	40% WFS
Initial \ day 1	1.047	3.398	3.446	2.584	3.380
Day 7	1.085	3.430	3.408	2.637	3.440
Day 14	1.094	3.449	3.508	2.639	3.445
Day 21	1.103	3.458	3.511	2.644	3.413
Day 28	1.105	3.460	3.471	2.625	3.420
Day 35	1.094	3.431	3.489	2.630	3.423

While the length of the mortar with 20% replacement of WFS increased by 0.0152 mm from day 1 to day 7 and continued to expand by 0.0248 mm from day 14 to 3.408, the length of the prism decreased by 0.0172 mm from day 1 to day 35 and the change in length was found to be 0.026 mm on day 21. Similar to the mortar with 30%, which expanded by 0.0212 mm from day 1 to day 7, continuing to expand by 0.022 mm in day 14, the change in length was found to be 0.024 mm on day 21, and

it was found to be 0.0164 mm on day 28, where it began to shrink on day 35, and the length of the prism decreased by 0.0184 mm, with a length of 2.630 mm from day 1. On day 7, the drying shrinkage of 40% WFS mortar was determined to be 3.380, which was 0.024 mm larger than the first day. On day 14, the expansion increased to 0.026 mm. The length changed on days 21, 28, and 35, becoming 0.0132 mm on day 21, 0.016 mm on day 28, and 0.0172 mm on day 35. The length change of cement mortar and drying shrinkage value for different replacement percentages of WFS is shown in Figures 4 & 5.

Table 6. Drying Shrinkage of Cement Mortar for different percentage replacement of WFS

Days	Length Change of Specimen at any age in %				
	Lx (0%)	Lx (10%)	Lx (20%)	Lx (30%)	Lx (40%)
7	0.0152	0.0128	0.0152	0.0212	0.024
14	0.0188	0.0204	0.0248	0.022	0.026
21	0.0224	0.024	0.026	0.024	0.0132
28	0.0232	0.0248	0.01	0.0164	0.016
35	0.0188	0.0132	0.0172	0.0184	0.0172

## 5. CONCLUSION

WFS may hurt the environment by being dumped in large numbers, which raises worries that it may harm the soil and harm agricultural regions or that it may impair groundwater that is used for agriculture. This is in addition to carefully assessing the cement mortar strength and drying shrinkage. The investigation produced the findings listed below.

- By replacing up to 10% of the sand in concrete with WFS, compressive strength is enhanced.
- With 10% WFS, the greatest improvement in compressive strength was noted at both 14 and 28 days.
- Depending on the quantity of waste foundry sand and the testing age, the increase in compressive strength against the third day and 28 day of the control mix ranged between 20% and 6%.
- As the amount of waste foundry sand replacement increased, there was an increase in cement mortar shrinkage when compared to the control mix.
- Based on the results of this experiment, it appears that waste foundry sand can be used to prepare high-quality cement mortar quite well.

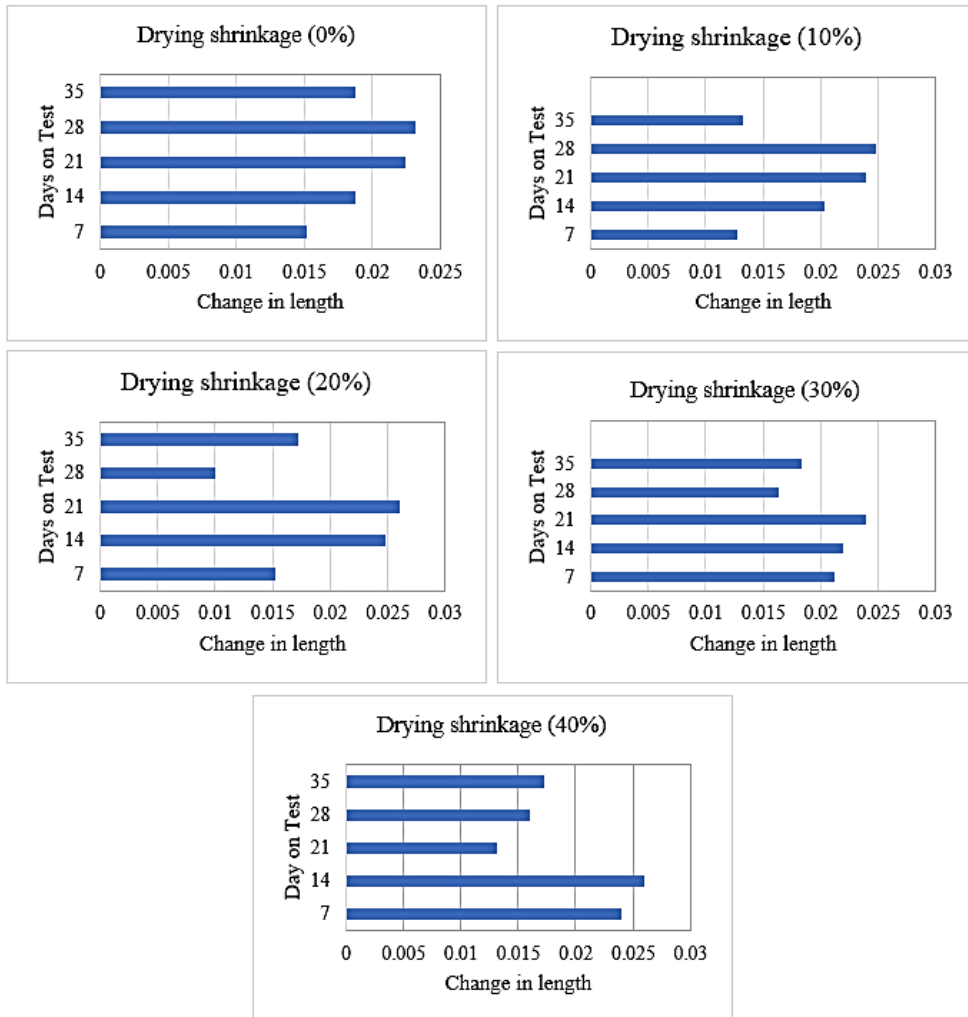


Figure 4. Variation of length change of prism for different replacement percentages of WFS

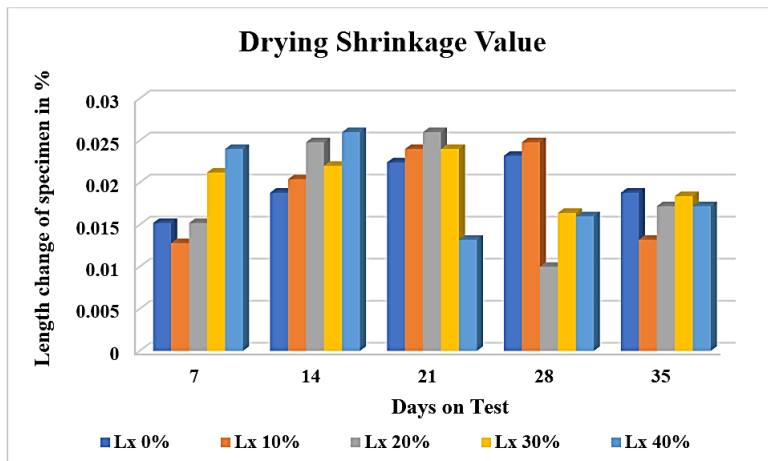


Figure 5. Variation of drying shrinkage for different replacement percentages of WFS



## REFERENCES

- [1] Bhardwaj, B, & Kumar, P: **Waste foundry sand in concrete: A review.** *Construction and building materials*, 156, 661-674, 2017.
- [2] Siddique, R: **Foundry Sand. In Waste Materials and By-Products in Concrete.** Springer, Berlin, Heidelberg, 381-406, 2008.
- [3] Gurpreet Singh and Rafat Siddique: **Effect of waste foundry sand (WFS) as partial replacement of sand on the strength, ultrasonic pulse velocity and permeability of concrete.** *Journal of Construction and Building Materials*, 26, 416-422, 2012.
- [4] Siddique, R, & Noumowe, A: **Utilization of spent foundry sand in controlled low-strength materials and concrete.** *Resources, Conservation, and Recycling*, 53(1-2), 27-35, 2008.
- [5] Tara Sen and Umesh Mishra: **Usage of Industrial Waste Products in Village Road Construction.** *International Journal of Environmental Science and Development*, Vol. 1, No. 2, 122-126, June 2010.
- [6] Evaggelia Petavratzi and Scott Wilson: **Foundry sand in facing bricks, Characterization of Mineral Wastes, Resources and Processing technologies.** *Integrated waste management for the production of construction material*, A case study, Nov. 2007.
- [7] Alberta C. Carpenter and Kevin H. Gardner: **Use of Industrial By-Products in Urban Roadway Infrastructure, Argument for Increased Industrial Ecology.** *Journal of Industrial Ecology*, Volume 13, Number 6, 965-977, 2009.
- [8] Kae-Long Lin, Ching-Jung Cheng, Ang Cheng, and Sao-Jeng Chao: **Study on recycled waste foundry sand as raw materials of cement additives.** *Sustainable Environment Research*, 22(2), 91-97, 2012.
- [9] Khatib, J M, Baig, S, Bougara A, and Booth C: **Foundry Sand Utilization in Concrete Production.** *Second International Conference on Sustainable Construction Materials and Technologies*, June 28-June 30, 2010.
- [10] Singh, G, & Siddique, R: **Abrasion resistance and strength properties of concrete containing waste foundry sand (WFS).** *Construction and building materials*, 28(1), 421-426, 2012.
- [11] Saveria Monosi, Daniela Sani and Francesca Tittarelli: **Used Foundry Sand in Cement Mortars and Concrete Production.** *The Open Waste Management Journal*, 3, 18-25, 2010.
- [12] De Barros Martins, M. A., Barros, R. M., Silva, G., & dos Santos, I. F. S.: **Study on waste foundry exhaust sand, WFES, as a partial substitute of fine aggregates in conventional concrete.** *Sustainable Cities and Society*, 45, 187-196, 2019.
- [13] Iqbal, M. F, Liu, Q. F, Azim, I, Zhu, X., Yang, J, Javed, M. F., & Rauf, M: **Prediction of mechanical properties of green concrete incorporating waste foundry sand based on gene expression programming.** *Journal of hazardous materials*, 384, 121322, 2020.

## BULGARIAN PRACTICE AND EXPERIENCE IN DESIGN DEVELOPMENT OF YOUTH CENTRES

Boriana Nozharova<sup>1</sup>

### Abstract

*Bulgarian practice and experience in design and development of youth centres dates back to the 1970s when the majority of them were built. Located mainly in the heart of the cities, a large number of youth centres have become cultural symbols of the places and formed a connected culture network. Nowadays the initial idea for such a national network is lost. Still, large and mid - size centres are still functioning. A significant number of the building stock has been preserved, but over time changes had been made regarding their function, content and ownership.*

*Inscribed in the city's skyline, youth centres are part of the memory of several generations that grew up there, but are completely unfamiliar to today's youth in terms of function and content. Present reality, especially in regard with the rapidly changing virtual environment and the constant flow of information require rethinking the nature and content of youth centres. Sociological studies conducted over the last ten years in Bulgaria show significant changes in the attitudes and necessities of the young generation. The creation of a "new space" meeting (facing) the needs of the youth should be a combination of different approaches and methods.*

*The present study explores the development and the existing condition of the buildings for the youth in Bulgaria. The main goal is to trace the transformation of the architecture of youth centres, their nature and cultural significance. The study is focused at the theoretical principles and regulations, and also shows specific examples from the Bulgarian architectural practice in the last 50 years.*

**Key words:** Youth centres, House of Youth, public architecture, principles and regulations, requirements

---

<sup>1</sup> Boriana Nozharova, M.Arch, PhD student, VFU "Chernorizets Hrabar", Faculty of Architecture, Department of Architecture and Urban Studies, Chaika Resort, Varna 9007, Bulgaria, [boriana.nozharova@vfu.bg](mailto:boriana.nozharova@vfu.bg)

## 1. INTRODUCTION

During the second half of the 20th century, after the wars, a directed state policy for the organization and development of youths began to be conducted worldwide. A model of organizing and regulating the activities of young people as national associations of a mandatory type were adopted in many European countries. Communities starting as spontaneously created units with ideal public interests were transformed. National plans for youth organization development, its structure, and its material base have been gradually drawn up and adopted.

In Bulgaria, the initial attempts, after the First World War, to create an organized state youth organization group failed. Rather, there are some separate associations and initiatives. This was the reason why the building stock of youth centres in Bulgaria began its development after the 70s of the XX century. However, in a very short period - only 15 years, youth homes had been built in all district towns in the country [1].

The structure creation was provoked in the course to find a natural and unforced continuation of the educational process of the youth outside of school in their free time. The initial idea of the House of Youth is to be functionally aligned with the wishes, needs, and interests of young people in their free time. In the late 1960s, in support of the design studies, general surveys were also conducted in five district cities, where the necessary activities and interests among the young generation were confirmed [2].

The official "cultural policy" conducted in the second half of the 20th century in the state allowed the simultaneous and rapid construction of youth homes, initially in fifteen regional cities of the country, and subsequently in all the other cities. The projects were strongly influenced by the modern architectural trends in the 60s and 70s and had as their main goal to materialize and reflect the understanding of culture and enlightenment. In 1974, patterns in the design of social and cultural club buildings were promulgated in Bulgaria, as a result of which the first buildings for youth culture had a common architectural vision and similar functional plans.

After 1989 and the changes in the country's politics and management, the network of youth homes stopped its planned expansion, and a significant part of the projects remained unrealized. Gradually, over the years, the established requirements for the functional content of social and cultural clubs for youth are falling away. Adopted and recognizable cultural youth homes change significantly their functional and architectural image, adopting the modern name "Youth Home".

Globally, today's urban structure highlights two demographic patterns: rapid urbanization and large youth populations [3]. In the last decade in Bulgaria, despite the fact that the cities are growing in scale, an increase in the average age of the urban population is reported - 45.2 years at the end of 2022 [4]. However, according to NSI data, by 2020 over 70% of young people under 30 live in cities. Gradually, over the years, young people become "active architects in the development of cities" [3].

Today, the construction of new youth centres in Bulgaria is still sporadic, mainly involving modernization and remodeling of existing ones. Within the framework of the presented study, the author examines and analyzes characteristic examples from Bulgaria, through which the development of youth centres, their essence, and importance, are traced.

## 2. PRINCIPLES FOR ORGANIZATION AND PLANNING OF YOUTH CENTRES IN BULGARIA.

In Bulgaria, there are different approaches and methods in planning and designing a social and cultural youth centre. More than 50 years after the opening of the first House of Youth in the country, two main periods of construction of youth centres are being followed: the first from 1968-1989 and the second from 2010 up to today. In the scientific literature on the subject, four basic levels have been adopted for the systematization of the principles and requirements of the organization of public buildings for culture and art: 1- urban planning requirements, 2- functional groups and principals, 3- planning requirements, and 4- composition principals.

## 3. URBAN PLANNING PRINCIPLES AND REQUIREMENTS.

Ever since their appearance in the 70s in Bulgaria, youth homes have been involved in shaping the urban centres of settlements. Specific for the period is their location in large independent properties, centrally located in the territory of the plot served by them, in order to ensure easy pedestrian access (*fig. 1*).



*Figure 1. Examples of urban planning solutions for Youth Centres built in the 1970s, author's scheme*

In an urban compositional aspect, buildings are most often organized as free-standing - accents in the context of the built-up and urbanized environment. According to the classification made by Popov in the 1960s, youth centres are divided into four main categories: small, medium, large, and very large.

Initially, the buildings of the youth centres were planned and realized mainly as low and wide-area structures - composed of several mutually complementary volumes. Their location near parks and pedestrian areas ensures maximum free space immediately around them and in front of their entrance spaces. Buildings are easily perceived from different visual angles, points of attraction for young people with their open and closed spaces. The large open spaces contain exhibition area, places for play, and recreation. At the end of the 20th century, youth centres were built in almost all regional cities of the country [5].

Gradually, architectural theory and practice bring out the main town planning requirements for determining the capacity of youth centres. Predetermining for them are the features of the settlement and territory: location; the size of the serviced area

and its population density; the number of the population served by the club; the nature and system of work; the availability of other similar objects in the area [5, 6].



Figure 2. Examples of urban planning solutions of Youth Centres in Bulgaria, designed after 2015, author's scheme

In modern architectural practice in Bulgaria, a different approach is observed in the siting and sizing of buildings for the youth. As a result, of the exhausted opportunities and development potential of ideal urban spaces, modern centres are often located in secondary urban zones or districts. The scale of the properties is limited and reduced and the grounds rarely have access to a park environment. The new buildings are compactly designed, due to limitations of the properties and areas in which they are located (fig. 2). A basic requirement for urban planning decisions is to seek integration with other public service objects. According to Simeonov, most often these are school buildings, complex service centres, universal halls, libraries and others [6].

### 3.1. Functional groups and principles.

In the 70s of the 20th century, Popov systematized four main functional groups and premises, which were fundamental in the planning of the large youth centres in Bulgaria. In a report presented by him, based on his research activity and studies of international experience, Popov defined the main groups not only by general functionality, but also by specific purpose of the premises included in them (fig. 3).

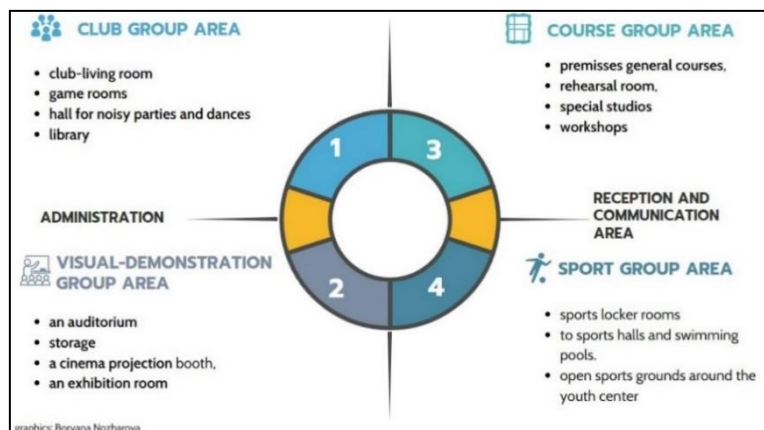


Figure 3. Scheme of types of functional groups in Youth Centres, as defined by Stefan Popov - 1968, author's diagram

Each zone is defined and determined by the capacity and size of the youth centres, as well as by a specific project assignment. In the 1980s, the normative documents that came into force defined the mandatory functional areas and their premises [9].

The first and main group is the club area, which should include: a club-living room, game rooms, a hall for noisy parties and dances, and a library [8]. The club-living room includes a corner for watching TV and a small buffet. It is used mainly for rest, conversations, and for "quiet" activities - chess, dominoes, raffle, and reading newspapers and magazines. The game rooms are equipped for table tennis, billiards, etc.). Some youth centres provide separate rooms for loud parties and dances (but not as a mandatory rooms). The library zone is organized for free access.

Next in importance and predetermining is the course group, including three types of premises: general universal course rooms, rehearsal rooms, and special studios (for sculpture and painting, radio and television, photography, etc.). The group often includes wood and metal workshops, with stores and/or an assembly room.

The third one is a visual-demonstration group, including a large auditorium for universal use, with the necessary utility rooms, make-up rooms, a cinema projection booth, and possibly an exhibition room.

As recommended and depending on the size of the youth centre, the last fourth group of sports facilities has been determined. The group included: sports locker rooms, sports halls, and swimming pools, etc. utility rooms.

The main functional groups are designed principally independently in separate volumes, united by a large reception area with recreational areas. Theoretically, Lazarov defined two types of recreation areas in project solutions: isolated - restrooms and game rooms, and non-isolated - hallways, living rooms, extended parts of the corridors [7].

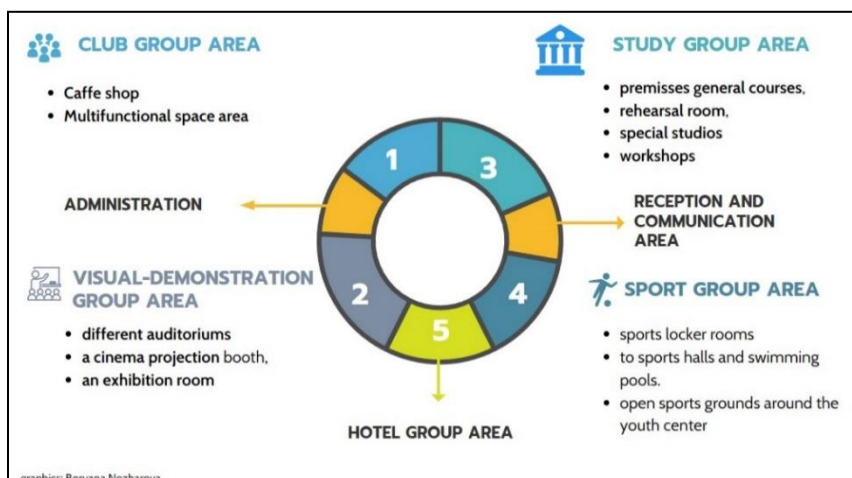


Figure 4. Scheme of types of functional groups in Youth Centres - contemporary practice of the 21st century, author's diagram

In modern architectural practice, the main functional groups have been preserved in their essence but have changed by content (fig. 4). Computer systems, virtual environments, and communication that have entered everyday life contribute to the

changes in the essence of functional groups. The premises for library activity gradually disappeared, and the area for club activity was mainly decided as an area with multifunctional studios or workshops.

The size of the auditorium has been rethought in the projects, preferring more halls with a smaller capacity. In the newly built buildings, a new group for temporary accommodation (hotel group area (fig. 4, fig. 6)) is included, analogical to the former international youth tourist service - "Orbita".

### 3.2. Planning principles and requirements

In the creation of the first rules and regulations for youth clubs, it was emphasized that *"...the center of life in them (compositional center) is the premises of the club-recreational group"* [7]. This perception is the main difference between the houses of Youth built in the same period and other cultural and art buildings: community centres, cultural centres, etc.

The Houses of Youth built in the 1970s have a predominantly free plan, which presupposes an easy awareness of the spaces and access to them. In the project solutions, differentiation and independent shaping of the individual functional groups of premises were sought. According to Lazarov, in the initial decisions, the proportion - the visual part to the club part 1:0,6 - 1:0,7, should be adopted for the larger centres (fig. 5) [7]. In the case of smaller youth homes with multi-functional solutions, complete isolation by groups is not necessary. The unification allows for a more complete use of the premises and in this way, the needs are used comprehensively.

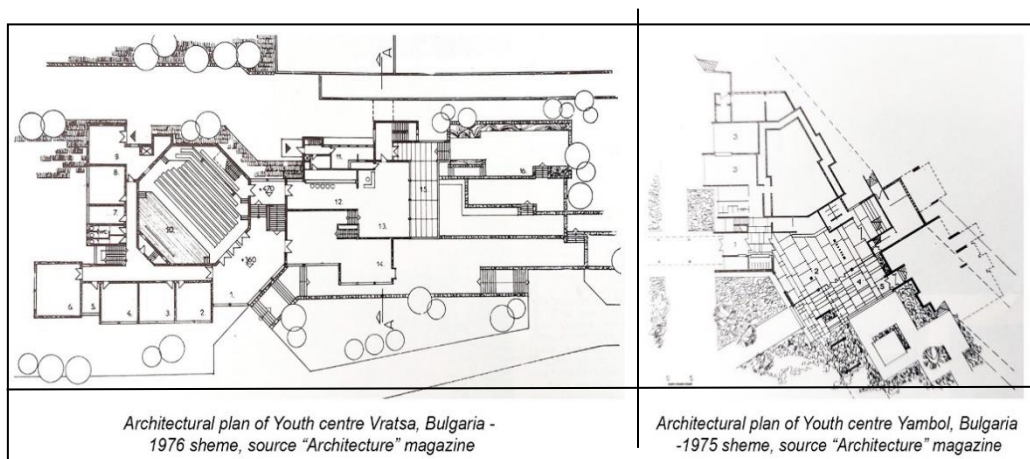


Figure 5. Examples of architectural practice in Bulgaria in the 70s [10,11], author's collage

Project solutions in the 1970s were distinguished by the variability of the distribution and the universality of the spaces, which allowed them to be united, dismembered, or redistributed over time. The buildings have been designed with priority horizontal development of people flows, avoiding tall and multi-story structures. Very large parts of the preserved buildings are being reconstructed and modernized today, changing only the purpose of some of the premises.

Despite the lack of any specific requirements for youth centres, today architectural practice has adopted completely analogous planning and design

principles. New structural systems and materials contribute to sustainable design in planning, taking into account the traditions accumulated over time (fig.6).

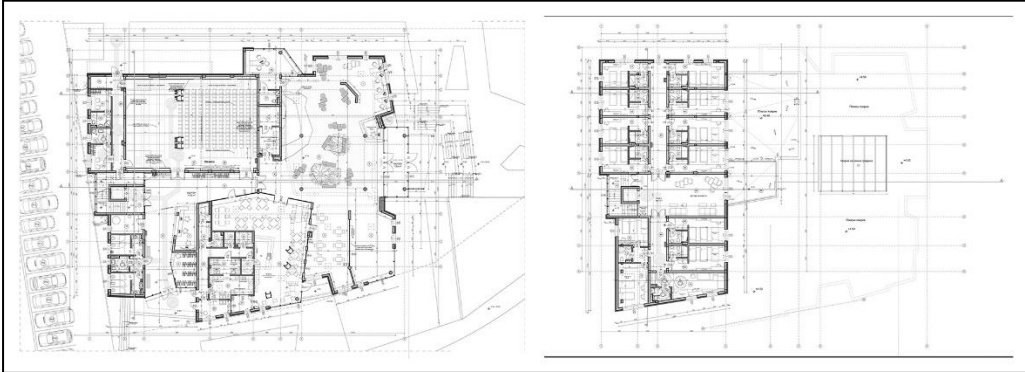


Figure 6. Architectural project for a new Youth Centre Burgas, Bulgaria 2020, source: <https://archinova.bg/winner/533>, author's collage

Leading planning principles and requirements in the design and planning of youth centres are theoretically: to ensure universality in the use of the premises, functional-spatial and structural flexibility, and to provide a generally accessible environment for all [6].

### 3.3. Composition principles and requirements

The compositional principles in the design and planning of the youth centres did not differ from those of the cultural and even some community centre buildings in the country.

In the various scientific studies and existing practice, some basic form-forming solutions are distinguished in terms of functional and volume composition: compact volume, with a central composition in plan; fragmented volume, with different height volumes (group of blocked buildings) and ensemble approach, large cultural centres (co-operated with other public buildings in separate buildings) (fig. 6) [4].

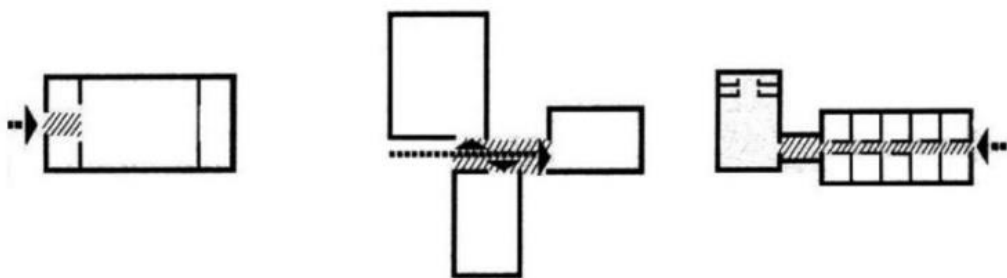


Figure 6. Scheme of forming solutions in functional compositional relation, source: Simeonov, and Asparuhov, *Architectural typology of buildings* (2019)

A large part of the youth centres, built in the past in Bulgaria, was designed as a volume-spatial composition of several bodies, united by a main lobby and with a large entrance space. Meaningful and organizational center in the composition are open or closed spaces: atrium, courtyard, forum, etc. The functional content and activities of the youth centres allow applying the principles of symmetrical and asymmetrical compositions in the plan. (fig. 5, fig. 7)



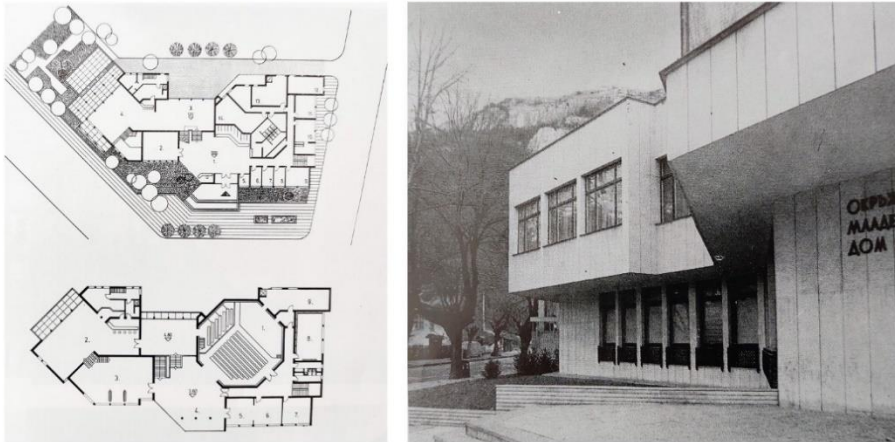


Figure 7. The House of Youth, Lovech, Bulgaria: architectural plans and photo from 1978, source: Architecture magazine №8 / 1978 [12], author's collage

The development and planning of the horizontal function, as well as the combination of spaces of different heights, predetermines to a large extent the compositional solutions in the exterior of the buildings. From the point of view of the volumetric solution, the principles of low and wide-area buildings stand out, with prominent vertical accents. The youth homes built in the 1970s have monumental architecture. Organized in contrasting volumes, they are irregularly geometric in plan and silhouette.

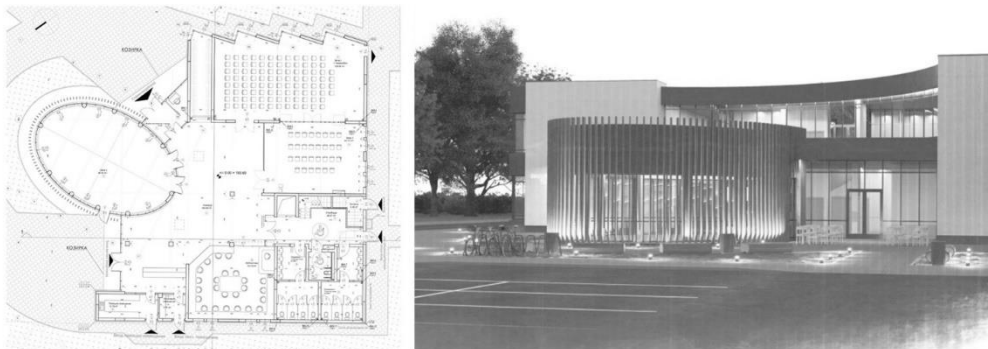


Figure 8. Architectural project for a new Youth Centre Targovishte, Bulgaria 2023, source: <https://www.citybuild.bg/> [13], author's collage

In contrast to the past, newly built project solutions are distinguished by compact and symmetrical compositions. In plan, the buildings have a simplified geometry without distinguishing separate volumes (fig. 6, fig. 8). In terms of volume and composition, the projects have a common and uniform silhouette, uniformly designed facades, and architectural elements (openings, etc.).

#### 4. CONCLUSION

Although the national material network created in the second half of the 20th century has lost its original idea, today the larger and medium-sized municipal youth centres are maintained in operation. Urbanization in the country has contributed to

the depopulation of the small youth centres, their reconstruction, and the change of overall purpose. A significant part of the building stock of the large youth centres has been preserved, but over time changes have been made in the content, ownership, and functioning of the objects.

There are huge changes in development and improvements in the world today. The modern social reality, the access to more public buildings with a multi-functional character have led to the lack of spontaneous visits to the youth centres. The idea of a space to organize the free time and recreation of the youth has gradually been restructured into a place for personal development and scheduled training. Part of the reason why young people do not recognize youth centres as places for rest and entertainment is precisely the change in the organization and activity of the centres.

Sociological studies conducted over the last ten years in Bulgaria report significant changes in the attitudes and needs of the young generation [14, 15]. Today's youth lives and develops in a much different way than in the past. The advancement of modern technology has greatly influenced people's ways of thinking, which has obviously led to their rejection of previous ideologies. Most of the principles that were valued in the past are now often criticized and even rejected. This circumstance should be applied in the field of architecture. The new needs hardly find a real material response from the side of architecture practice. Today's architectural principles and styles try to break away somewhat from the traditions of public architecture of the 70s. Creating a "space" responsive to the needs of youth must be a combination of different approaches and methods.

## REFERENCES

- [1] Yosifov Y, Nikolova P, Dusheva E.: **Public buildings (from the experience of design organizations)**, Ed. "Technique", Vol. I, Sofia., 1975.
- [2] Semov, M.: **What do young people think about youth homes /survey/:** *professional magazine "Architecture"*; No. 4-5; pp. 19-20, 1969.
- [3] Are Our Cities Built for the Youth?, <https://www.archdaily.com/968455/are-our-cities-built-for-the-youth> (30.6.2023)
- [4] <https://www.prv.bg/naselenie-i-demografski-proczeni-prez-2022-godina/> (30.6.2023)
- [5] Popov, S.: **The House of Youth in Kardzhali** // *professional magazine "Architecture"*; No. 6, pp. 11-12, 1975.
- [6] Simeonov Ts., Asparuhov S.: **Architectural typology of buildings**, "Technical University - Sofia" Publishing House; ISBN: 978-619-167-378-0, 2019.
- [7] Lazarov V.: **Public buildings**, Ed. "Technique", Vol. I and II, Sofia, 1975.
- [8] Popov, S.: Basic architectural and construction problems in the creation of youth homes in our country // *professional magazine "Architecture"*; No. 4-5, pp. 14-18, 1969.
- [9] **Standards for the design of social and cultural clubs**, Bulgarian state standard, BDS – from April 20, 2016 norms shall be considered invalid, due to the fact that the basis for their issuance has ceased to exist: <https://zbut.eu/docs/law/normi-proektirane-obshtestveni-klubove.pdf>
- [10] Tihchev, R.: **The House of Youth in Yambol** // *professional magazine "Architecture"*, No. 1, pp. 9-12, 1975.
- [11] **The Youth Centre in Vratsa** // *professional magazine "Architecture"*, No. 10, pp. 27-29, 1976.

- [12] Evrev, P.: **The House of Youth in Lovech** // *professional magazine "Architecture"*, No. 8, pp. 14-17, 1978.
- [13] <https://www.citybuild.bg/news/obshtina-targovishte-podade-proektno-predlojenie-za-izgraidane-na-mladejki-centar> (30.6.2023)
- [14] **Strategy for the development of culture 2019-2029**, Ministry of Culture - Sofia, 2019, <https://www.strategy.bg/PublicConsultations/View.aspx?lang=bg-BG&Id=4155> (30.6.2023)
- [15] **Bulgarian Youth 2018/2019**, *report under the program "Research on youth in South-Eastern Europe 2018/2019"*, <https://library.fes.de/pdf-files/bueros/sofia/15287.pdf> (30.6.2023)

# THE CONSTRUCTION PROJECT EFFICIENCY OF PIER HEAD STRUCTURE DESIGN USING THE HIGH YIELD STRENGTH STEEL

Agung Fajarwanto<sup>1</sup>, Arry Aryadi<sup>2</sup>, G. Aji Sentosa<sup>3</sup>, Harry Budi Prasetya<sup>4</sup>, Eri Dwi Wibawa<sup>5</sup>, Annisa Dewanti Putri<sup>6</sup>, Muhammad Ilham Aditya<sup>7</sup>, Faridz Mohammad Edrie<sup>8</sup>

## Abstract

*The high-grade steel as one of an advanced important material which has been used in the concrete construction has to consider more to the quality and grade. Meanwhile, the cost issue is one of the considerations to the use to the construction. In this occasion, Hutama Karya Group with a corporation with PT Bhirawa Steel has done a research and innovation to the High-Grade Steel Structure especially for type 520 MPa reinforcing steel which includes the development to the Tensile strength, Yield Strength, Elongation from the strength of the materials. High-Grade Steel will be a solution to the cost efficiency of a construction especially for the Pier Head Design. Nowadays, the use are only permitted for the non-structural part based on the written requirement from National Standard in Indonesia (SNI 2847: 2019), even though the test requirements for structural needs are already fulfilled. The study was to apply it to the pier head design along with the highway construction using the simulation and modelling, as in the study the comparison between the normal steel structure (420 MPa) and the high-grade steel (520 MPa) was made. This study may be one of the proofs to the cost efficiency of using the High-Grade Steel materials in pier head which is more 12% efficient to the use of the high grades steel to the pier head structure.*

**Key words:** Efficiency, High Grade Steel, Pier Head Design, Material, Road Infrastructure

---

<sup>1</sup> Operation Director 1, PT. Hutama Karya (Persero), [agung.fajarwanto@hutamakarya.com](mailto:agung.fajarwanto@hutamakarya.com)

<sup>2</sup> Director, PT Bhirawa Steel, [Arry.aryadi@hutamakarya.com](mailto:Arry.aryadi@hutamakarya.com)

<sup>3</sup> Executive Vice President, PT. Hutama Karya (Persero), [aji.sentosa@hutamakarya.com](mailto:aji.sentosa@hutamakarya.com)

<sup>4</sup> Managing Director, PT. Bhirawa Steel, [harrybudi\\_prasetya@yahoo.com](mailto:harrybudi_prasetya@yahoo.com)

<sup>5</sup> Vice President, PT. Hutama Karya (Persero), [eri.wibawa@hutamakarya.com](mailto:eri.wibawa@hutamakarya.com)

<sup>6</sup> Researcher, PT. Hutama Karya (Persero), [annisa.dewanti@hutamakarya.com](mailto:annisa.dewanti@hutamakarya.com)

<sup>7</sup> Researcher, PT Hutama Karya (Persero), [muhammad.ilham@hutamakarya.com](mailto:muhammad.ilham@hutamakarya.com)

<sup>8</sup> Researcher, PT Hutama Karya (Persero), [faridz.edrie@gmail.com](mailto:faridz.edrie@gmail.com)

## **1. INTRODUCTION**

In the construction field especially for materials, steel, as one of the materials which must have a quality which is good with the other supporting materials, in which it bonds with the concrete mixture. High strength steels offer several advantages over conventional steels, particularly where weight is important [1]. The strength to the materials, fabrication, distribution, safety factor, and application are the most things that must be considered regarding to the High-Grade Steel category. However, in recent years there has been an increasing interest in the use of higher strength steels for these installations, recognizing the benefits from an increase in the strength to weight ratio and the associated savings in the cost of materials [1]. High-strength steel (HSS) contributes to reduced cross-sectional area, resulting in lighter structures (or greater strength ratio), greater clearance height and easier fabrication and inspection [2]. The composite use of high strength materials is a potential way of achieving more sustainable construction [3]. Hutama Karya Group with PT Bhirawa Steel initiated to conduct the research to the High-grade steel innovation especially for the 520 MPa High-grade still known as BJTS 520 in Indonesia. The application also is already adjusted to the grade on the SNI 2052:2017 [4]. The importance of sustainable construction in Indonesia has created a sense of urgency, leading to research objectives focused on innovation. These objectives encompass various areas, such as investigating the incorporation of High-grade steel into road barrier design, enhancing other types of high-grade steel, optimizing cost-effective production methods to support the desired quality, and establishing a timeline for accepting innovations related to high-grade steel. As part of this effort, a simulation was conducted comparing the use of 520 MPa and 420 MPa steel, highlighting the cost efficiency of the former for construction projects.

## **2. HIGH GRADE STEEL**

High Grade reinforced concrete steel bars are a type of steel used as reinforcement in reinforced concrete structures. With high tensile strength, high grade reinforced concrete steel bars can withstand larger loads and provide good resistance to pressure and tensile forces. Additionally, these steel bars exhibit good ductility, allowing them to absorb deformation energy and prevent sudden structural failure. High grade reinforced concrete steel bars are essential in ensuring the strength, reliability, and long-term durability of reinforced concrete structures in various construction.

### **2.1. Application**

The application of high grade reinforced steel has become a common choice in the construction of structures that require increased strength and durability. High grade reinforced steel exhibits superior mechanical properties, including high tensile strength, good ductility, and enhanced resistance to corrosion and fatigue. These characteristics make it highly suitable for construction projects such as bridges, high-rise buildings, and heavy-load infrastructure.

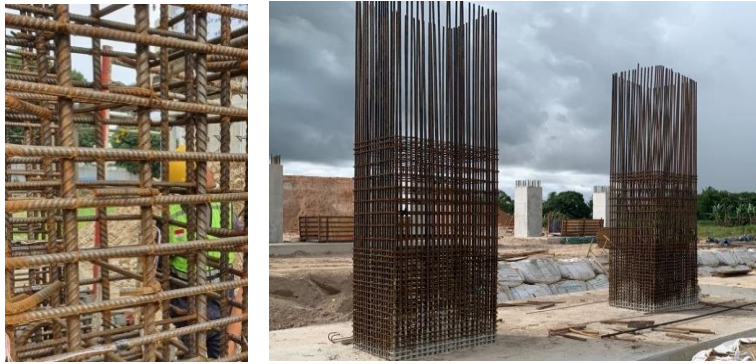


Figure 1. Use of High Grade Steel

The use of High-grade steel in toll road column as shown in Figure 1 for the Padang Sicincin Project in South Sumatera, Indonesia. Additionally, high-quality reinforced steel allows for lighter and more streamlined structural designs, reducing construction costs and offering advantages in terms of construction speed. With its wide range of applications, high-quality reinforced steel has become an effective solution in meeting the demands for strength and performance in modern structures.



Figure 2. The High-grade strength Steel, Bhirawa Steel

## 2.2. Mechanical Properties

Reinforced steel bars possess crucial mechanical properties that determine the strength and performance of reinforced concrete structures. The primary mechanical properties of steel reinforcement include tensile strength, yield strength, and elasticity. Tensile strength refers to the ability of the steel bars to resist pulling forces before experiencing failure. Yield strength corresponds to the maximum load that can be sustained before the steel bars begin to deform permanently. Elasticity describes the capability of the steel reinforcement to return to its original shape after a load is applied and then removed. Additionally, other mechanical properties include compressive strength, hardness, toughness, and flexural strength. Understanding and considering these mechanical properties are essential in the design of reinforced concrete structures to ensure adequate safety, reliability, and durability against applied loads during the structure's service life.

The utilization of high-grade steel poses certain challenges in its application for the Indonesian construction market, particularly in high-rise buildings, bridges, piers, and other non-structural earthquake-resistant structures. However, meeting the requirements specified in ASTM A706 M is necessary in order to use this type of steel effectively.

Table 1. Table requirements to the Tensile strength from ASTM A706 M

Aspect	Grade 60 [420 MPa]	Grade 80 [550 MPa]
Tensile Strength, Min. Psi [MPa]	80,000 [550]	
Yield strength, min. psi [MPa]	60.000 [420]	80 000 [550]
Yield Strength, max. psi [MPa]	78 000 [540]	98 000 [675]
Elongation in 8 in [200 mm], min, %		
Bar Designation Nos. 3, 4, 5, 6 [10, 13, 16, 19]	14	12
Nos. 7, 8, 9, 10, 11 [22, 25, 29, 32, 36]	12	12
Nos. 7, 8, 9, 10, 11 [22, 25, 29, 32, 36]	10	10

It is important to note that the required value of  $f_{yt}$  (tensile yield strength) for meeting design standards is limited. On the other hand, ASTM A706 M specifies lower strength requirements for alloy poles, with a minimum of 420 MPa and 550 MPa. However, only the 420 MPa strength is permitted in seismic systems due to insufficient data requirements to support the application of higher-grade strength standards for certain structures.

### 2.3. Fabrication & Production

Fabrication and production of reinforced steel bars are crucial processes in the construction of reinforced concrete structures. During this stage, the steel bars are prepared and manufactured to be used as reinforcements in concrete. The fabrication process involves cutting, bending, and tying the steel bars according to the structural design. Subsequently, the fabricated steel bars are produced in the required quantity for the construction project. The production process entails the manufacturing and delivery of the steel bars in the form of rods, coils, or other prefabricated products. The produced steel bars must meet the established quality standards and specifications to ensure the strength and reliability of the reinforced concrete structure being built.

## 3. METHODOLOGY

The research method is to do the simulation analysis using the design method of the pier head with steel structure. In which, the preliminary discussion to the paper are mostly to the literature review and product knowledge related to the High Grade Steel strength. The method is to compare the analysis to the use of the High Grade Steel of 520 compared to the 420. From the simulation the comparison between the cost efficiency and volume can be used based on the design simulation of the structure as shown in Figure 2 for the simulation analysis of the pierhead design.

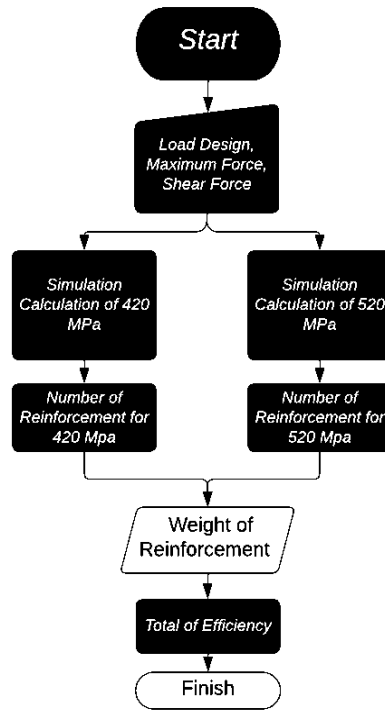


Figure 3. Flowchart Diagram for Pierhead Design

#### 4. PRELIMINARY

The preliminary use to the High-grade Steel strength is accordance on the mechanical properties' requirements between the conventional steel and High-grade steel which is using the comparison between the 420 B with the 520 which is already provided in the countries standard.

Table 2. Mechanical Properties Requirements Between the Conventional Steel and High-Grade Steel

Type of Steel	Tensile Test		Bending Test			Ratio
	Yield Strength [YS]	Tensile Strength (TS)	Strain within 200, within min	Angle	Curve Angle	
420B	Min 420 Max 545	Min. 525	14 (d ≤ 19 mm)	180 °	3.5d (d ≤ 16 mm)	Min. 1,25
			12 (22 ≤ d ≤ 36 mm)	180 °	5d (19 ≤ d ≤ 25 mm)	
			10 (d > 36 mm)	180 °	7d (29 ≤ d ≤ 36 mm)	
				90 °	9d (29 ≤ d ≤ 25 mm)	
520	Min. 520 Max. 645	Min. 650	7 (d ≤ 25 mm)	180 °	5d (29 ≤ d ≤ 36 mm)	Min. 1,25
			6 (d ≥ 29 mm)	180 °	7d (29 ≤ d ≤ 36 mm)	
				90 °	9d (d > 36 mm)	



Note:

1. D is the steel bar nominal diameter
2. The test result of the bending test which may not show the crack from the outer bend of the material

The numbers 420 B and 520 refer to specific grades or types of steel. These numbers often correspond to the yield strength of the steel, which is an important mechanical property. Yield strength is the amount of stress a material can withstand before it starts to deform plastically. The comparison between 420 B and 520 indicates a comparison between the yield strengths of these two types of steel.

## 5. SIMULATION

In this part, the simulation to the pier head design between the 420 MPa and 520 MPa are discussed in this chapter. The process of calculation is represented overall for the 420 MPa, as the ending will conclude the comparison between the use to 420 and 520 MPa. The limitation to the simulation as shown is without including the earthquake load by using the function as shown as:

$$\rho = \frac{A_{st}}{bd} = \frac{K_c^R - \sqrt{(K_c^R \cdot f_{xy})^2 - 2.4K_c^R \cdot \left(\frac{M^u}{bd^2}\right) \left(\frac{f_{sy}^2}{f_c}\right)}}{1.2K_c^R \left(\frac{f_{xy}^2}{f_c}\right)} \quad (1)$$

Shear Formula equation are shown as below:

$$V_s = V_n - V_c \quad (2)$$

$$V_s = V_u / f \quad (3)$$

$$V_{smax} = \frac{2}{3} \sqrt{f_c'} \cdot b_w \cdot d \quad (4)$$

$$V_{smax} = \frac{A_v \cdot f_y \cdot d}{s} \quad (5)$$

Meanwhile, the Torque Formula

$$T_{nd} = \frac{T_{ud}}{f} \quad (6)$$

$$T_{cr} = 0.328 \cdot \sqrt{f_c'} \frac{A_{cp}^2}{P_{cp}} \sqrt{1 + \frac{f_{px}}{0.328 \cdot \sqrt{f_c'}}}} \quad (7)$$

$$T_u > 0.25 \cdot f \quad (8)$$

$$T_c = \sqrt{\frac{f_c' \times Mpa}{12}} \times \left(\frac{A_{cp}^2}{P_{cp}}\right) \quad (9)$$

**Maximum force (envelope)**

section 1-1 (negative Moment)

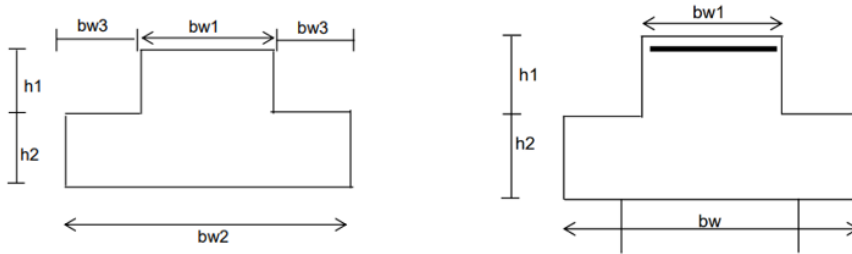
My = 4.368.140.000 Nmm

$$M_x = 4\,520\,000.000 \quad \text{Nmm}$$

$$F_z = 5\,190\,000.000 \quad \text{N}$$

Table 3. The Dimension to the Steel Grade

	bw-1	bw-2	bw-3	Cover dc	Long. Reinf.	Trans. reinf.	H1	H2	Kc <sup>R</sup>	γ <sub>c</sub>	f <sub>c</sub> '	f <sub>y</sub> '
Dim	4,0 m	5,8 m	0,9 m	50,0 mm	32,0 mm	22,0 mm	1,7 m	1,0 m	0,75	25 kN/m <sup>3</sup>	30 Mpa	420



**Flexure Reinforcement:**

- $M_{u1} = 4368140000 \text{ Nmm}$
- $dc = 2537.00 \text{ mm}$
- $bw = 5800 \text{ mm}$

$$\rho = \frac{A_{st}}{bd} = \frac{K_c^R - \sqrt{(K_c^R \cdot f_{xy})^2 - 2.4K_c^R \cdot \left(\frac{M_u}{bd^2}\right) \left(\frac{f_{sy}^2}{f_c}\right)}}{1.2K_c^R \left(\frac{f_{xy}^2}{f_c}\right)} \quad (10)$$

- $M_u/bd^2 = 0.1170$
- $A_{st}/bd = 0.000373$
- $A_{st} = 5483.1 \text{ mm}^2$

**Check Minimum Reinforcement:**

$$\rho_{min} = 0.00333$$

- $** A_{smin} = \frac{1.4 \text{ Mpa} \cdot bw \cdot d}{f_y}$  (11)
- $= 49048.7 \text{ mm}^2$
- $A_{s'} = 49048.67 \text{ mm}^2 \rightarrow 61 \text{ pieces of } 32\text{mm diameter rebar}$
- $\text{Rounded to } 33 \text{ pieces --- } 32\text{mm diameter rebar (layer 1)}$
- $\text{Rounded to } 33 \text{ pieces --- } 32\text{mm diameter rebar (layer 2)}$
- $A_s = 53053.44 \text{ mm}^2$

Ratio of Reinforcement:  $\rho = A_{st}/bw \cdot d$   
 $= 0.003605497 \text{ OK}$

**Shear Design:**

$$V_{u1} = 5185000.0 \text{ N}$$

$$V_c = 0.166 \times \text{sqrt}(f_c') \times bw \times d = 13378800.5 \text{ N}$$

$$V_n = V_u / \emptyset \quad \emptyset = 0.7$$

$$= 7407142.9 \text{ N} \quad \text{if } V_n \leq VC \text{ (no need Shear Reinforcement)}$$

$$V_s = V_n - V_c = -5971657.6 \text{ N}$$

$$V_{smax} = \frac{2}{3} \sqrt{f_c} \cdot b_w \cdot d = 53730122.3 \text{ N}$$

$$V_s = \frac{A_v f_y d}{s}$$

$$\begin{aligned} \text{Area of Stirrups/space } A_{vs} &= \frac{V_s}{f_y \cdot d} \\ &= 0,0 \text{ mm}^2/\text{mm} \end{aligned}$$

### Shear Design due to Moment Torsion :

$$A_{cp} = b_w \cdot h = 12600000 \text{ mm}^2$$

$$A_{oh} = (b_w - 2d_c) \times (h - 2d_c) = 10770000 \text{ mm}^2$$

$$P_{cp} = 2(b_w + h) = 17000 \text{ mm}$$

$$P_{oh} = 2((b_w - 2d_c) + (h - 2d_c)) = 16100 \text{ mm}$$

### Torsion Moment Design :

$$T_{ud} = 452e+09 \text{ Nmm}$$

$$T_{nd} = \frac{T_{ud}}{\phi}$$

$$T_{nd} = 6.46 \text{ E}+09 \text{ Nmm}$$

$$\text{if conditional : } T_{cr} = 0.328 \cdot \sqrt{f_c} \frac{A_{2CP}}{P_{cp}} \sqrt{\left(1 + \frac{f_{px}}{0.328 \sqrt{f_c}}\right)} \quad (12)$$

$$T_{cr} = 1.68 \text{ E}+10$$

$$0.25 \phi T_{cr} = 2.94 \text{ E}+09$$

If conditional  $T_u > 0.25 \phi T_{cr}$  torsion must be investigated

### Torsion Capacity from concrete

$$T_c = \frac{\sqrt{f_c} \cdot M_{pa}}{12} \times \left(\frac{A_{2cp}}{P_{cp}}\right) \quad (\text{if } T_{nd}, T_c \text{ torsion effect can be neglected})$$

$$= 4. \text{ E}+09 \text{ Nmm}$$

### Area of shear reinf. /space:

$$A_{ts} = \frac{T_{nd}}{2 \cdot 0,85 \cdot A_{oh} \cdot f_{ys} \cdot \cot 45}$$

$$= 0.8400 \text{ mm}^2/\text{mm}$$

### Check minimum Reinforcement

$$A_{smin} = 1/3 (b_w \cdot s) / f_y = 1380.95 \text{ mm}^2$$

Note:  $A_{vt} > A_{v \text{ min}}$ . OK

### a. Shear Friction

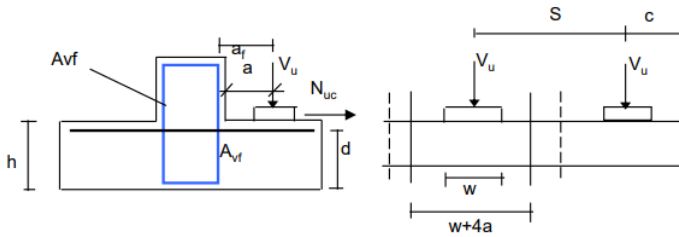


Table 4. Table for dimension Achieved

	a	w	L	S	C	Øs	Øm	d	μ	h	af	h'	beff
Dim	450 mm	650 mm	600 mm	2400 mm	1550 mm	0,7	0,85	937,5 mm	1,4 (monolit)	1000 mm	516 mm	62,50 mm	2450 mm

$$Vu \leq 0,2 \times \emptyset \times fc' \times (w+4a)d \dots \dots \dots \text{if } (w+4a) < s$$

$$Vu \leq 0,2 \times \emptyset \times fc' \times S \times d \dots \dots \dots \text{if } (w+4a) > s$$

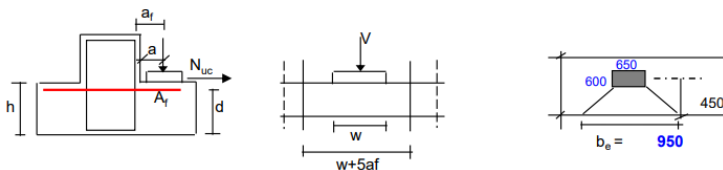
$$Vu \leq \emptyset \times \mu \times Avf \times fy$$

$$Avf = \frac{Vu}{\emptyset \cdot \mu \cdot fy}$$

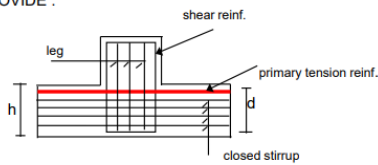
	DL+LL	Selfweight	Total (N)	
Vu (N)	2372320,30	78000	2450320,30	
$0,2 \times f \times fc' \times s \times d$			315000	$(w+4a) > S$
Avf (mm <sup>2</sup> )			5953,20	

Using D-22 Space -150mm  
 Avf= 6838.9 mm<sup>2</sup>

**Flexure & Direct Tension**



PROVIDE :



$$Mu = Vu \times af + Nuc \times (h-d)$$

$$An = Nuc / \phi \times fy$$

Vu (N)	Nuc (N)	Mu (Nmm)	As/bd	pmin	Af(mm <sup>2</sup> )
2450320,3	490064,1	1294994279	0,00194	0,00333	2304,73

**Direct Tension**

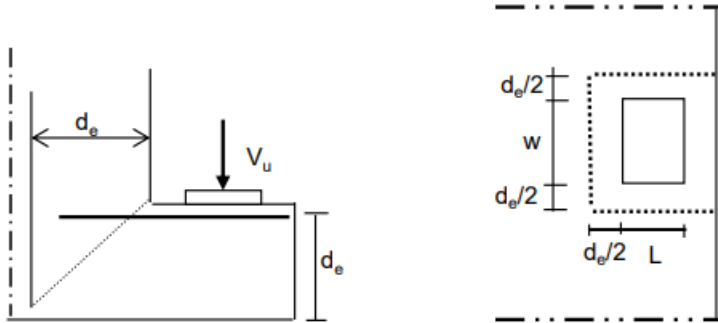
Control : (ACI 318-95 page 17-2)

The Greater of : a.  $A_v f + A_n$   
 b.  $3/2 \times A_f + A_n$

if a.b : Primary Tension Reinforcement =  $A_s = 2/3 A_v f + A_n$   
 Closed Stirrup =  $A_h = 1/3 A_v f$

if a.< b. : Primary Tension Reinforcement =  $A_s = A_f + A_n$   
 Closed Stirrup =  $A_h = 1/3 A_f / 2$

**Check Punch Shear**



$D_e = 937.5 \text{ mm}$

$V_n = 0.328 \sqrt{f_c} (w + L + d_e) d_e$   
 $V_n = 3684290.016 \text{ N} > V_u \dots\dots\dots \text{OK}$

Table 5. Table Pierhead Reinforcement of BJTS-420

NO.	DIA. (mm)	TYPE	DIMENSION (mm)				TOTAL LENGTH (mm)	UNIT WEIGHT (Kg/m)	NUMBER	WEIGHT (Kg)
			a	b	c	d				
P1	32	C	2500	13880	2500		18880	6.31	66	7863
P2	32	C	800	13880	800		18880	6.31	45	5361
P3	25	C	800	13600	800		15200	3.85	14	819
P4	22	C	2600	3570-3710	2600		8840	2.98	86	2266
P4-1	19	AB	3570-3710	50			3740	2.23	43	359
P5	25	C	900	5370-5510	900		7240	3.85	86	2397
P5-1	25	B	4470-4610	1050			5590	3.85	86	1851
P5-2	25	B	5370-5510	900			6340	3.85	86	2099
P6	16	A	13240				13240	1.58	6	126
P6-1	16	A	13240				13240	1.58	4	84
P6-2	19	A	13360				13360	2.23	2	60
P6-3	19	A	13360				13360	2.23	4	119
P7	19	BC	300	4200	300		4800	2.23	172	1841
P8	16	F	2600	300	50		5600	1.58	176	1557
P8-1	16	F	1050	300	50		2500	1.58	44	174
P8-2	16	F	900	300	50		2200	1.58	44	153
P9	13	C	800	1170	600		2370	1.04	24	59
P10	13	B	1375	600			1975	1.04	24	49
SUB TOTAL									27237	

Table 5. Table Pierhead Reinforcement of BJTS-520

NO.	DIA. ( mm )	TYPE	DIMENSION (mm)				TOTAL LENGTH (mm)	UNIT WEIGHT (Kg/m)	NUMBER	WEIGHT (Kg)
			a	b	c	d				
P1	32	C	2500	13880	2500		18880	6.31	52	6195
P2	32	C	800	13880	800		18880	6.31	38	4527
P3	25	C	800	13600	800		15200	3.85	14	819
P4	22	C	2600	3570-3710	2600		8840	2.98	86	2266
P4-1	19	AB	3570-3710	50			3740	2.23	43	359
P5	25	C	900	5370-5510	900		7240	3.85	86	2397
P5-1	22	B	4470-4610	1050			5590	2.98	86	1433
P5-2	22	B	5370-5510	900			6340	2.98	86	1625
P6	16	A	13240				13240	1.58	6	126
P6-1	16	A	13240				13240	1.58	4	84
P6-2	19	A	13360				13360	2.23	2	60
P6-3	19	A	13360				13360	2.23	4	119
P7	19	BC	300	4200	300		4800	2.23	172	1841
P8	16	F	2600	300	50		5600	1.58	176	1557
P8-1	16	F	1050	300	50		2500	1.58	44	174
P8-2	16	F	900	300	50		2200	1.58	44	153
P9	13	C	600	1170	600		2370	1.04	24	59
P10	13	B	1375	600			1975	1.04	24	49
SUB TOTAL										23843

The subtotal weight of the use to High steel strength grade 420 MPa is 27237 kg for overall. In which the 520 MPa has a total weight of 238843 Kilogram of steel bar for the pier head design. The number shows that the use of 520 can be lesser than the normal steel strength. In this case it will decrease the total cost to the pier head design.

## 6. CONCLUSION

For general summary, the use to the high steel strength of 520 can be decreased as it can be seen from the total weight required for the study case which is 23.843 Kilogram, as meanwhile for the grade 420 MPa requires 27.237 Kilogram. It can be concluded that the efficiency from the conventional Steel with the High-Grade steel strength has come to 14 %, in which the use to the high grade steel of 520 MPa has given the best material selection for the steel instruction. More further, the development to the high grade steel strength can be used for structural project to achieve efficiency.

## ACKNOWLEDGMENTS

A grateful acknowledgment are delivered to PT Hutama Karya and PT Bhirawa Steel as the fund and research support for the High-Grade steel Research. The financial support from the company has driven to many improvements and development to the research and use of the 520 High-grade steels in the projects around Indonesia. Especially as this paper was focusing in the simulation to the Trans Toll Sumatera Toll Road section for the implementation.

## REFERENCES

- [1] Billingham J, Sharp JV, J Spurrier, J Kilgallon 2003 Review of the Performance of High Strength steels used offshore (Bedfordshire: HSE Books)
- [2] Chrysanthos M, Zacharias C F, and Konstantinos D T 2017 Mechanical Properties of High and very High Steel at elevated temperatures and after cooling down. DOI 10.186/s40038-017-0017-6. Fire Science Reviews (2017) 6:3

- [3] Xiong M X, Wang Y, Liu X and Chen G 2021 Editorial: Composite Use of High Strength Steel and Concrete Materials for Sustainable Civil Engineering. *Front. Mater.* 8:723587. doi: 10.3389/fmats.2021.723587 p 1
- [4] Standard Nasional Indonesia (SNI) 2052: 2017. *Baja Tulangan Beton*. Badan Standarisasi Nasional (BSN).
- [5] Comparative Analysis of Cost and Time on Pier Head Elevated Works with Sosrobahu and Conventional Methods
- [6] Chan, Titchenda, "Ultra-High Performance Concrete for Precast Seismic Bridge Column Connection" (2019). *Electronic Theses and Dissertations*. 6462 (Format sitasi)
- [7] Saša Marinković, Bojan Milošević, Stefan Mihajlović, Marijana Jančićević, Žarko Petrović, Serviceability limit state analysis of a cracked cross-section in accordance with SRPS EN1992-1-1 and PBAB'87, X International Conference "Heavy Machinery-HM 2021", Faculty of Mechanical and Civil Engineering in Kraljevo, University of Kragujevac, ISBN 978-86-81412-09-1, G.33-G.41, Vrnjačka Banja, June 23–25, 2021

## INFLUENCE OF DIFFERENT TYPES OF FIBERS ON PROPERTIES OF CONCRETE

Marko Stojanović<sup>1</sup>, Lana Antić-Arandelović<sup>2</sup>, Ksenija Janković<sup>3</sup>,  
Dragan Bojović<sup>4</sup>, Zeljko Flajs<sup>5</sup>

### Abstract

*The paper presents the influence of the use of different types of fibers on the properties of concrete. All concrete samples were made with same component materials and compositions, except for the amount of fibers, which was varied. After hardening, the concrete samples were tested for compressive strength, tensile splitting strength and water penetration depth under pressure. Based on the test results, depending on the type, shape, amount and arrangement of fibers, the tensile and compressive strength values as well as the depth of water penetration under pressure were analyzed. Based on the tests performed, the best mechanical properties were achieved with the use of "Dramix 3D" steel fibers.*

**Key words:** *compressive strength, splitting tensile strength, water penetration depth under pressure*

---

<sup>1</sup> Professional adviser, PhD candidate, IMS Institute, Belgrade, Serbia, marko.stojanovic@institutims.rs

<sup>2</sup> Professional adviser, MSCE, IMS Institute, Belgrade, Serbia, lana.antic@institutims.rs

<sup>3</sup> Principal research fellow, IMS Institute, Belgrade, Serbia, ksenija.jankovic@institutims.rs

<sup>4</sup> Research associate, IMS Institute, Belgrade, Serbia, dragan.bojovic@institutims

<sup>5</sup> Professional adviser, PhD candidate, IMS Institute, Belgrade, Serbia, zeljko.flajs@institutims.rs



## 1. INTRODUCTION

Concrete is the most commonly used building material for decades. Due to industrialization and urbanization its demand has increased rapidly in the last few years. The use of concrete in construction has a significant impact on the environment because it consumes a large number of natural resources, and the production of cement also pollutes the environment [1]. It is a brittle material with high compressive strength and relatively low tensile and flexural strength, about 8–10% of its compressive strength [2], [3]. One of the solutions to enhance its tensile strength and achieve ductile behaviour is to introduce steel and polypropylene fibers, resulting in fiber-reinforced concrete (FRC) [4]. The tensile and flexural strengths of concrete can be substantially increased by fibre reinforcement which can effectively prevent the brittle propagation of cracks [5].

Fibers are embedded in this concrete that increase the concrete's tensile, compressive, impact, and flexure strength [6]. As a result of their bridging effect, fibers contribute to the strength of concrete after cracking and prevent the propagation of small fractures. The addition of fibers led to a significant increase in the post-cracking strength of concrete [7].

Recently the use of polypropylene fibers as a substitute for steel fibers has become increasingly common. In this work, testing of compressive strength, tensile strength by splitting, as well as testing of water penetration under pressure was carried out.

## 2. EXPERIMENTAL RESEARCH

### 2.1. Materials used in the experiment

Fiber Reinforced Concrete was made with ordinary Portland cement with added slag CEM II/A-S 42.5 R Našice cement. The limestone filler as a filler "Agro Hemik" was used as a mineral additive. Natural fractionated stone aggregate of fractions 0/4, 4/8, 8/16, 16/32 mm from the Drina River was used. Polypropylene fibers with a length of 60 mm and a diameter of 0.84 mm manufactured by "Sika Fiber Force" in the amount of 2, 3 and 4 kg/m<sup>3</sup> were used in this research. Steel fibers with hooks at the ends in quantities of 20 kg/m<sup>3</sup>, manufactured by "Dramix 3D" with a length of 60 mm and a diameter of 0.75 mm and manufactured by "Spajić" with a length of 50 mm and a diameter of 1.05 mm, were used.

Fiber-reinforced concrete is made of composite Portland cement with the addition of CEM II / A-S 42.5 R slag from the manufacturer Našice cement, the aggregate is from the Drina river fraction 0/4, 4/8, 8/16, 16/32 mm, mineral admixture Type I of limestone origin is from the manufacturer "Agro Hemik" and superplasticizer "Sika Viscocrete 4077x", while the fibers used are polypropylene fibers from the manufacturer "Sika Fiber Force" and steel fibers from the manufacturers "Dramix" and "Spajić".

Chemical composition of cement and limestone is provided in Table 1.

Table 1 - Chemical compositions of cement

Oxide		SiO <sub>2</sub>	Al <sub>2</sub> O <sub>3</sub>	Fe <sub>2</sub> O <sub>3</sub>	CaO	MgO	K <sub>2</sub> O	SO <sub>3</sub>	LoI at 1000°C
Content %	Cement	21.85	5.73	2.26	60.13	3.11	0.79	3.18	1.62
	Limestone	1.07	0.39	0.06	54.54	0.77	0.06	0.02	42.88

The appearance and type of the fibers are shown in Figure 1.



a) polypropylene fiber "Sika Fiber Force"



b) steel fiber "Dramix"



c) steel fiber "Spajić"

Figure 1. The appearance and type of the fibers.

Basic characteristics of fibers are showed in Table 2.

Table 1 - Basic characteristics of fibers.

Material properties	SikaFiber Force	Dramix 3D, 80x60 BG	Spajic ZS/N 1.05x50
Fiber Type	Polypropylene	Steel	Steel
Fiber shape	Straight embossed	Straight hooked ends	Straight hooked ends
Bundling	Bundled	Glued	Loose
Length l [mm]	60	60	50
Diameter d [mm]	0.84	0.8	1.05
Aspect ratio (l/d)	0.71	0.75	0.47
Tensile strength [N/mm <sup>2</sup> ]	465	1225	1250
Modulus of elasticity [GPa]	7.5	200	200

## 2.2. Concrete mixture

Three mixtures of three-fraction concretes were prepared for this experiment.

The concrete mix was designed so that the recommended limit values for the composition of the concrete mix according to SRPS EN 206:2021 are met [8]. Fresh concrete meets the requirement for consistency class S4 (160-210 mm), and the air content in fresh concrete is within 1-3%.

All types of concrete were made with  $w/c=0.524$ . Fiber reinforced concrete compositions are showed in Figure 2.

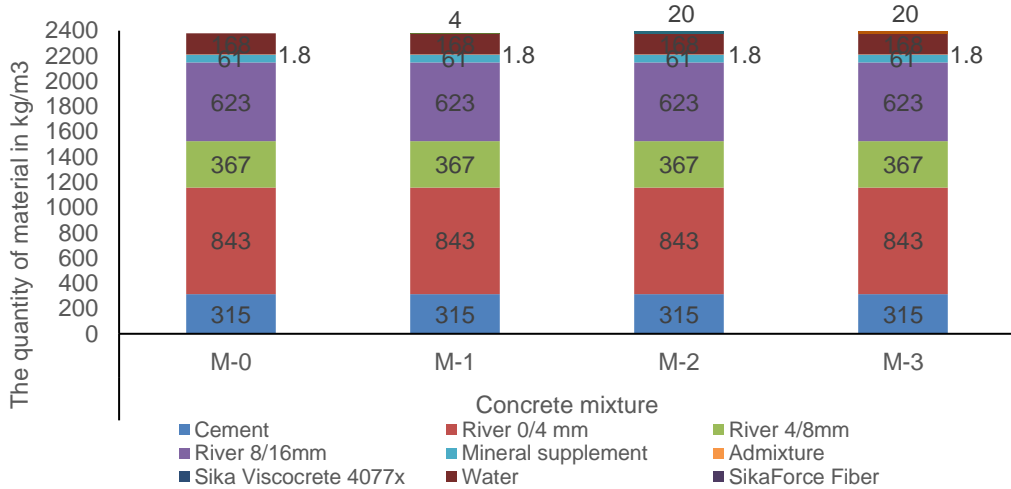


Figure 2. Fiber reinforced concretes compositions.

### 3. RESULTS AND DISCUSSION

For the purposes of testing the compressive strength of fiber-reinforced concrete, cube-shaped samples of dimensions  $150 \times 150 \times 150 \text{ mm}^3$  were made. Concrete with fibers was compacted with a vibrating needle in metal molds that cured in water at a temperature of  $+20^\circ\text{C}$  until the moment of testing according to the SRPS EN 12390-2 standard.

#### 3.1. Compressive strength

The compressive strength of concrete was tested at the age of 28 days according to SRPS EN 12390-3 [9]. The samples were tested until fracture using a laboratory digital hydraulic press with load of 2000 kN and servo control of the increment speed of 0.80 MPa/s. The test results are shown in Figure 3.

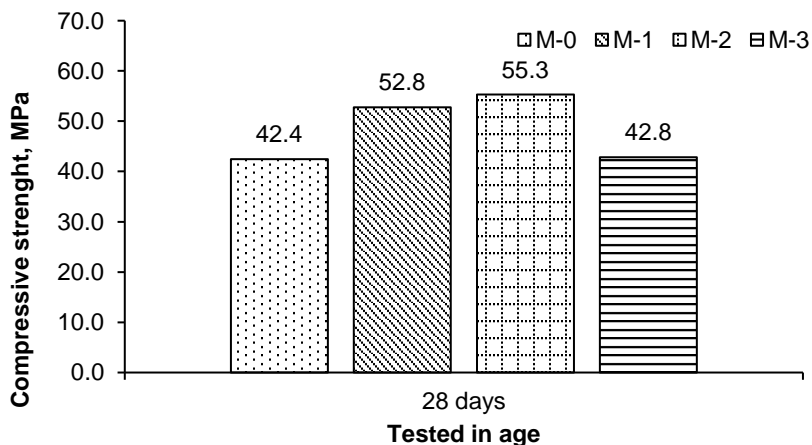


Figure 3. Results of testing the compressive strength at the age of 28 days.

### 3.2. Tensile splitting strength

Tensile splitting strength was performed on cube-shaped concrete samples with edge dimensions  $d=150$  mm, which was exposed to a linear load in the middle of the lower and upper sides of the sample showed in Figure 4.



Figure 4. Disposition of the tensile splitting strength test by the concrete sample.

The linear load was applied via a digital hydraulic press of 300 kN with a load application speed of 0.06 MPa/s until obtaining the highest value of the breaking force. The tensile splitting strength was tested at the age of 28 days according to SRPS EN 12390-6 [10].

The values obtained from the test results are shown in Figure 5.

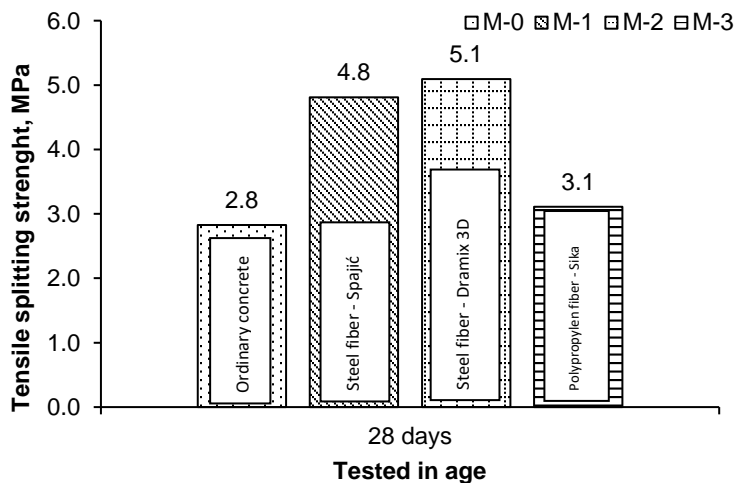


Figure 5. Results of testing the tensile splitting strength at the age of 28 days.

### 3.3. Depth of water penetration under pressure

The regime of testing according to the standard SRPS EN 12390-8 was used, under which the water with pressure of 500 kPa (5 bar) applied on the surface of the concrete sample for 72 hours. After testing, the amount of water absorbed in concrete is measured. In order to measure the depth of water penetration into concrete, the concrete sample is exposed by linear load on the half-side of the

samples on both sides to split into two parts. The maximum penetration of water under pressure into the concrete is measured on the fractured surfaces of the concrete.

The depth of water penetration under pressure was tested at the age of 28 – 31 days according to SRPS EN 12390-8 [11].

Results of depth of water penetration under pressure are showed in Figure 6.

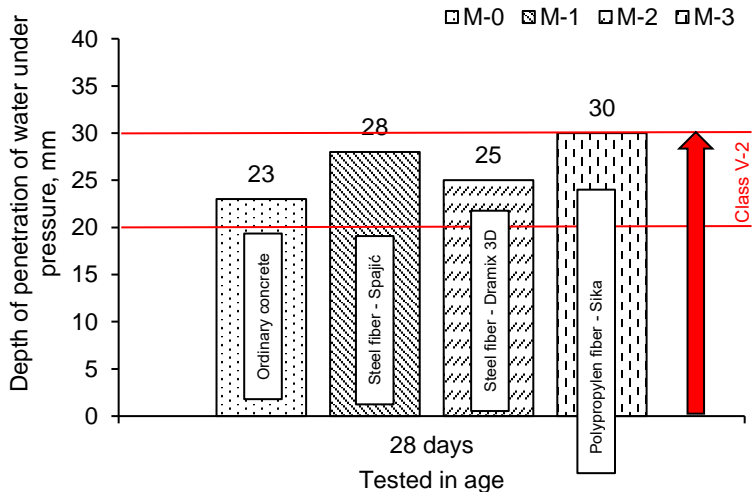


Figure 6. Results of testing the tensile splitting strength at the age of 28-31 days

#### 4. CONCLUSION

The values obtained by testing the compressive strength samples for fiber-reinforced concrete, mixture marks M-1 to M-3, have higher values than ordinary concrete mixture mark M-0 by 24.3%, 30.4% and 0.9%, respectively.

The values obtained by testing the tensile splitting strength of fiber-reinforced concrete samples, mix marks M-1 to M-3, achieved higher results compared to the ordinary concrete mix, mix mark M-0 by 70%, 80% and 10%, respectively.

The depth of penetration of water under pressure into concrete samples of hardened concrete indicates the state of the capillary pores in the cement stone. If we have a good, compact structure of concrete, we will get less penetration of water under pressure into hardened concrete. The highest values of water penetration under pressure were obtained for fiber-reinforced concrete, mix marks M-1 to M-3, which are higher than ordinary concrete, mix mark M-0, by 22%, 30% and 9%, respectively.

Based on the obtained results, we can conclude that the concrete reinforced with steel fibers produced by "Dramix 3D" achieved the highest results of mechanical tests (compression and tension by splitting) and the lowest value of water penetration under pressure, compared to other fiber-reinforced concrete.

## ACKNOWLEDGMENTS

This investigation is financially supported by The Ministry of Science, Technological Development and Innovation of the Republic of Serbia (contract no.: 451-03-47/2023-01/ 200012).

## REFERENCES

- [1] A.F. Hashmi, M. Shariq, A. Baqi, Use of HVFA concrete for sustainable development: a comprehensive review on mechanical and structural properties, *Arab. J. Sci. Eng.* 12 (2022 May) 1–24.
- [2] S.P. Shah, S.E. Swartz, C. Ouyang, *Fracture mechanics of concrete: applications of fracture mechanics to concrete, rock and other quasi-brittle materials*, John Wiley & Sons, 1995 Sep 28.
- [3] A. Fuzail Hashmi, M. Shariq, A. Baqi, Successive sustained loading effect on the long-term deflection of flat slab, *SN Appl. Sci.* 2 (11) (2020 Nov) 1–2.
- [4] Harvinder S. *Steel fiber reinforced concrete: behavior, modelling and design*. Springer Singapore. 2017. Google Scholar.
- [5] P.K. Mehta, P.J.M. Monteiro *Concrete: microstructure, properties, and materials* (3d ed.), McGraw Hill Professional, New York (2005) Google Scholar.
- [6] C. Frazão, A. Camões, J. Barros, D. Gonçalves, Durability of steel fibre-reinforced self-compacting concrete, *Constr. Build. Mater.* 1 (80) (2015 Apr) 155–166.
- [7] R.S. Olivito, F.A. Zuccarello, An experimental study on the tensile strength of steel fibre-reinforced concrete, *Compos. B Eng.* 41 (3) (2010 Apr 1) 246–255.
- [8] EN 206: 2013 + A2:2021 – Concrete. Specification, performance, production and conformity
- [9] SRPS EN 12390-3:2019 - Testing hardened concrete - Part 3: Compressive strength of test specimens.
- [10] SRPS EN 12390-6:2012 - Testing hardened concrete - Part 6: Tensile splitting strength of test specimens.
- [11] SRPS EN 12390-8:2019 - Testing hardened concrete - Part 8: Depth of penetration of water under pressure

## DEVELOPING THE DATABASE OF WEFE NEXUS PROJECTS AND CASE STUDIES

Žarko Vranjanac<sup>1</sup>, Stefania Munaretto<sup>2</sup>, Alexandra Spyropoulou<sup>3</sup>,  
Tamara Rađenović<sup>4</sup>, Dejan Vasović<sup>5</sup>, Snežana Živković<sup>6</sup>

### Abstract

*In light of one of NEXUSNET's goals regarding the provision of a unified standardized way of mapping and presenting relevant existing tools within Nexus components (water, land and soil, energy, food, climate, ecosystems, and waste), the focus of this paper is to develop the database of Nexus projects and case studies. Within the paper, two databases of NEXUS projects and case studies were processed. The first one refers to information about 85 projects related to NEXUSNET Cost Action, in which Excel worksheets for case studies were developed for all projects. The second one refers to the available contact information for all projects. The authors investigated project websites, as well as funders' websites and Google searches regarding missing data about projects and case studies. As part of the research, in order to fill in all the missing information a useful tool in the form of a questionnaire for project coordinators was created with specified contact information*

**Key words:** WEFE, NEXUS, database, projects, case studies

---

<sup>1</sup>MSc, Research Assistant, Innovation Center, University of Nis, Serbia, zarevranjanac@gmail.com

<sup>2</sup>PhD, Senior Scientific Researcher, KWR Water Research Institute, Netherlands, Stefania.Munaretto@kwrwater.nl

<sup>3</sup>PhD, Research Associate, Department of Civil Engineering, University of Thessaly, Greece, aespypoulou@gmail.com

<sup>4</sup>PhD, Assistant professor, Faculty of Occupational Safety, University of Nis, Serbia, tamara.radjenovic@znrfak.ni.ac.rs

<sup>5</sup>PhD, Associate professor, Faculty of Occupational Safety, University of Nis, Serbia, dejan.vasovic@znrfak.ni.ac.rs

<sup>6</sup>PhD, Professor, Faculty of Occupational Safety, University of Nis, Serbia, snezana.zivkovic@znrfak.ni.ac.rs

## 1. INTRODUCTION

NEXUSNET is an international network comprised of researchers collaborating with universities, research institutions, policymakers, and the corporate sector. Their goal is to enhance comprehension of how the interconnections between water, energy, and food (referred to as the Nexus) contribute to coherent policies and physical interactions in these domains. This effort supports the shift towards a circular, environmentally-friendly economy in Europe. The network concentrates on multiple objectives including job generation, improved well-being, synergies establishment, and environmental conservation. They examine the Nexus concept across various scales (local, regional, national, and European) and include international contributors to explore its global dimensions. Sharing of knowledge and research at a European and wider level is intended to promote more practices in line with the Nexus framework. Public-private collaborations are instrumental in adopting Nexus-aligned approaches, drawing from the advice of network members. NEXUSNET aims to showcase instances of policies and decision-making that adhere to Nexus principles, offering recommendations to effectively implement them. This initiative seeks to compile a comprehensive overview of successful Nexus Practices in Europe, covering policy coherence, Nexus-conforming practices, and more consistent evaluations. The network employs interdisciplinary methodologies involving relevant stakeholders to test these practices, while also engaging with ongoing and concluded projects related to the Nexus. Academic expertise related to the Nexus is translated into pragmatic insights for the benefit of the private sector and policymakers. The network plans a series of robust knowledge exchange and dissemination activities to ensure its meaningful impact in Europe and beyond. The organizational structure of NEXUSNET consists of an organizational hierarchy on three levels: Management Committee, Main contacts and leadership and six Working Groups (WG). WGs are organized as follows:

- WG1: Monitoring and modelling the Nexus
- WG2: Nexus applications
- WG3: Policy measures
- WG4: Outreach
- WG5: Organization and monitoring of events
- WG6: Stakeholder coordination [1].

COST (European Cooperation in Science and Technology) is a funding agency for research and innovation networks. The COST Mission was given the green light in 2018 by the decision-making body of the organization, known as the Committee of Senior Officials (CSO). According to this decision, COST aims to create networking opportunities for researchers and innovators, with the aim of enhancing Europe's ability to tackle scientific, technological, and societal challenges. The primary strategic focal points of this COST Action are as follows: a) Promoting and spreading excellence, b) Fostering interdisciplinary research for breakthrough science, and c) Empowering and retaining young researchers and innovators. COST carries out its mission by providing funding for grassroots, excellence-oriented, transparent, and all-encompassing networks that serve peaceful objectives across various scientific and technological domains [2].

Although a very modern concept, the WEF nexus is still not sufficiently represented in relation to traditional methods that especially dominate in the domain



of development projects, investments, and interstate contracts (in this sense, the COST action CA20138 represents a significant contribution to the change of traditional "respond and fix settings") [3].

Having in mind one of the NEXUSNET goals which is to provide a unified standardized way of mapping and presenting relevant existing tools within the Water, Energy, Food, Climate, Ecosystems, Land use and Waste Management issues, the focus of this paper is development of the Nexus projects and Case studies platform [4,5]. This is a horizontal product of the NEXUSNET project that is implemented by the WG2, T2.2 team. The platform will be an online, interactive tool that will host nexus case studies. Per each case study the user will be able to see detailed information concerning a wide range of attributes such as nexus sectors investigated, methodologies used, scale of implementation, stakeholder engagement approaches, etc. The platform will also allow users to extract information based on specific queries, e.g., on scale, on nexus sectors, on data analysis methods, etc. Users will be able to upload their own Nexus case study and relevant information. The case studies' attributes have already been identified and are currently under review.

In order to make it more concise, this paper is organized in the following sections: 1. Introduction, 2. Methodology, 3. Results and discussion, and 4. Conclusion.

## **2. METHODOLOGY**

Expanding the current database of nexus case studies and development of content for the online nexus platform, two databases on projects related to the NEXUSNET COST Action were processed. All project websites were investigated (85), as well as funders' websites and Google searches regarding missing data. A Questionnaire was created for all project coordinators in order to more efficiently obtain missing data regarding case studies and contact information.

In the first table, which refers to information about projects related to NEXUSNET COST Action, Excel worksheets for case studies information were developed for all 85 projects. The database in the second table contains information about case studies and projects including contact information of project coordinators available for 85 projects. The created Questionnaire for project coordinators with specified contact information especially contribute to the NEXUSNET COST Action objective and deliverables, as a useful tool along the way to find all the missing information.

## **3. RESULTS AND DISCUSSION**

In this part of the paper, the results related to the content elements of both tables, as well as the questionnaire, including examples, are presented. The database in Table 1 shows the required data that should be processed for all projects addressed to NEXUS (Figure 1) [6,7,8].

SINARG 2023 CONFERENCE, NIŠ, 14-15 SEPTEMBER 2023

ORDER	TO BE CONSIDERED	COMMENT	TYPE OF PROJECT	PROJECT NAME	TITLE OF PROJECT
1	Y	Fits the requirements: nexus and EU funding	RIA	SIM4NEXUS	Sustainable Integrated Management for the NEXUS of water-land-food-energy-climate for a resource-efficient Europe
2	Y	Fits the requirements: nexus and EU funding	RIA	NEXOGENESIS	Facilitating the next generation of effective and intelligent water-related policies utilising artificial intelligence and reinforcement learning to assess the water-energy-food-ecosystem (WEFE) nexus
3	Y	Fits the requirements: nexus and EU funding	IA	NEXUS-NESS	NEXUS Nature Ecosystem Society Solution: Fair and Sustainable Resource Allocation Demonstrator of the Multiple WEFE Nexus Economic, Social and Environmental Benefit Is for Mediterranean Regions

FUNDER'S WEBSITE	PROJECT WEB PAGE	FUNDER	STARTING YEAR	DATES	FOCUS OF PROJECT
<a href="https://cordis.europa.eu/project/id/689150">https://cordis.europa.eu/project/id/689150</a>	<a href="https://www.sim4nexus.eu/">https://www.sim4nexus.eu/</a>	H2020	2016	2016-2020	Applied research
<a href="https://cordis.europa.eu/project/id/101003881">https://cordis.europa.eu/project/id/101003881</a>	<a href="https://hexogenesis.eu/">https://hexogenesis.eu/</a>	H2020	2021	2021-2025	Applied research
<a href="https://prima-med.org/projects/nexus-ness/">https://prima-med.org/projects/nexus-ness/</a>	<a href="https://prima-nexus-ness.org/">https://prima-nexus-ness.org/</a>	PRIMA	2021	2021-2024	Technology development

PROJECT THEME	PROJECT COORDINATOR-CONTACT PERSON	CONTACT E-MAIL ADDRESS	CASE STUDY	CONTACT
Modeling and serious games on WEFE	Floor Brommer (Coordinator)	<a href="mailto:sim4nexus@wur.nl">sim4nexus@wur.nl</a>	✓	✓
Understanding of the impact of policies on the WEFE nexus by exploiting artificial intelligence	Janee Suñik (Coordinator)	<a href="mailto:j.suñik@un-the.org">j.suñik@un-the.org</a>	✓	✓
Co-produce and co-test with stakeholders WEFE Nexus management plans for fair and sustainable allocation of resources.	Fernando Nardi (Coordinator)	<a href="mailto:watmedoc@unistrappo.it">watmedoc@unistrappo.it</a>	✓	✓

Figure 1. Database in the Table 1

Figure 2 shows an example of an Excel worksheet with case study data related to the project as part of the database in Table 1 [6].

SIM4NEXUS		
CASE STUDY	CASE STUDY COORDINATOR	COORDINATOR E-MAIL ADDRESS
Greece	Chrysi Laspidou	<a href="mailto:laspidou@uth.gr">laspidou@uth.gr</a>
Sweden	Claudia Teutschbein	<a href="mailto:claudia.teutschbein@geo.uu.se">claudia.teutschbein@geo.uu.se</a>
Latvia	Daina Indriksone	<a href="mailto:Daina.Indriksone@bef.lv">Daina.Indriksone@bef.lv</a>
Transboundary - Upper Rhine	Maité Fournier	<a href="mailto:m.fournier@acteon-environment.eu">m.fournier@acteon-environment.eu</a>
European	Jason-Levin Koopman	<a href="mailto:jason.levin-koopman@wur.nl">jason.levin-koopman@wur.nl</a>
Devon/Cornwall - UK	Ben Ward	<a href="mailto:bdward@southwestwater.co.uk">bdward@southwestwater.co.uk</a>
Netherlands	Vincent Linderhof	<a href="mailto:vincent.linderhof@wur.nl">vincent.linderhof@wur.nl</a>
Spain	Maria Blanco	<a href="mailto:maria.blanco@upm.es">maria.blanco@upm.es</a>
Transboundary - DE/CZ/SK	Tobias Conradt	<a href="mailto:conradt@pik-potsdam.de">conradt@pik-potsdam.de</a>
Global	Jonathan Doelman	<a href="mailto:jonathan.doelman@pbl.nl">jonathan.doelman@pbl.nl</a>
Azerbaijan	Eunice Ramos	<a href="mailto:epamos@kth.se">epamos@kth.se</a>
Sardinia	Antonio Trabucco	<a href="mailto:atrabucco@uniss.it">atrabucco@uniss.it</a>
Romania (Lower Danube)	Albert Scricciu	<a href="mailto:albert.scricciu@geoecomar.ro">albert.scricciu@geoecomar.ro</a>

Figure 2. Excel worksheet with case study information in Table 1

Figure 3 shows the type of database in Table 2, with example data for the MAGIC project and case studies related to the project as part of the database in Table 2 [9].

ID	Project acronym	Project/CS information							Contact details				
		Full name of project/CS	Webpage	Type of project	Funder	Funder link	Starting year	End year	Type or research (applied, tech development, etc.)	Topic	Country	Coordinator name	Coordinator email
12	MAGIC	Moving Towards Adaptive Governance in Complexity: Informing Nexus Security	<a href="https://magic-nexus.eu/">https://magic-nexus.eu/</a>	RIA	H2020	<a href="https://cordis.europa.eu/project/id/889669">https://cordis.europa.eu/project/id/889669</a>	2016	2020	Applied research	Nexus policy and governance at the interface of water-food, food-biodiversity, energy-water-climate	4CS-EU and non-EU	Mario Giampietro	<a href="mailto:mario.giampietro@unizar.es">mario.giampietro@unizar.es</a>
12.1	MAGIC	External limits at the planetary level (Illustrations of MUSAISEM) - Methodological	<a href="https://magic-nexus.eu/">https://magic-nexus.eu/</a>	RIA	H2020		2016	2020	Applied research		Spain	Mario Giampietro	<a href="mailto:mario.giampietro@unizar.es">mario.giampietro@unizar.es</a>
12.2	MAGIC	The metabolic pattern of Spain (Illustrations of MUSAISEM) - Methodological Case	<a href="https://magic-nexus.eu/">https://magic-nexus.eu/</a>	RIA	H2020		2016	2020	Applied research		Spain	Mario Giampietro	<a href="mailto:mario.giampietro@unizar.es">mario.giampietro@unizar.es</a>
12.3	MAGIC	The electric grid of Catalonia (Illustrations of MUSAISEM) - Methodological Case	<a href="https://magic-nexus.eu/">https://magic-nexus.eu/</a>	RIA	H2020		2016	2020	Applied research		Spain	Mario Giampietro	<a href="mailto:mario.giampietro@unizar.es">mario.giampietro@unizar.es</a>
12.4	MAGIC	Animal production system in Scotland (Illustrations of MUSAISEM) - Methodological Case	<a href="https://magic-nexus.eu/">https://magic-nexus.eu/</a>	RIA	H2020		2016	2020	Applied research		Scotland	Mario Giampietro	<a href="mailto:mario.giampietro@unizar.es">mario.giampietro@unizar.es</a>
12.5	MAGIC	Vegetable production in Almeria (Illustrations of MUSAISEM)	<a href="https://magic-nexus.eu/">https://magic-nexus.eu/</a>	RIA	H2020		2016	2020	Applied research		Almeria	Mario Giampietro	<a href="mailto:mario.giampietro@unizar.es">mario.giampietro@unizar.es</a>
12.6	MAGIC	Desalination for agriculture using wind energy in Gran Canaria (Illustrations of MUSAISEM)- Methodological Case	<a href="https://magic-nexus.eu/">https://magic-nexus.eu/</a>	RIA	H2020		2016	2020	Applied research		Spain	Mario Giampietro	<a href="mailto:mario.giampietro@unizar.es">mario.giampietro@unizar.es</a>
12.7	MAGIC	Circular Economy - Policy case	<a href="https://magic-nexus.eu/">https://magic-nexus.eu/</a>	RIA	H2020		2016	2020	Applied research		Spain	Mario Giampietro; Zora Kovacic	<a href="mailto:mario.giampietro@unizar.es">mario.giampietro@unizar.es</a> ; <a href="mailto:zorkovacic@gmail.com">zorkovacic@gmail.com</a>
12.8	MAGIC	Environmental policy - Policy case	<a href="https://magic-nexus.eu/">https://magic-nexus.eu/</a>	RIA	H2020		2016	2020	Applied research		Netherlands	Raimon Ripoll Bosch	<a href="mailto:raimon.ripollbosch@unizar.es">raimon.ripollbosch@unizar.es</a>
12.9	MAGIC	Water Framework Directive - Policy case	<a href="https://magic-nexus.eu/">https://magic-nexus.eu/</a>	RIA	H2020		2016	2020	Applied research		Netherlands	Joep Schyns	<a href="mailto:j.schyns@unizar.es">j.schyns@unizar.es</a>
12.10	MAGIC	Common Agricultural Policy - Policy case	<a href="https://magic-nexus.eu/">https://magic-nexus.eu/</a>	RIA	H2020		2016	2020	Applied research		United Kingdom	Keith Matthews	<a href="mailto:keith.matthews@unizar.es">keith.matthews@unizar.es</a>
12.11	MAGIC	Energy Directives - Policy case	<a href="https://magic-nexus.eu/">https://magic-nexus.eu/</a>	RIA	H2020		2016	2020	Applied research		Spain	Mario Giampietro	<a href="mailto:mario.giampietro@unizar.es">mario.giampietro@unizar.es</a>
12.12	MAGIC	Policy Solution Green Bonds - Innovation Case	<a href="https://magic-nexus.eu/">https://magic-nexus.eu/</a>	RIA	H2020		2016	2020	Applied research		Netherlands	Jan Sindt	<a href="mailto:jan.sindt@unizar.es">jan.sindt@unizar.es</a>
12.13	MAGIC	Saving Water in Irrigation - Innovation Case	<a href="https://magic-nexus.eu/">https://magic-nexus.eu/</a>	RIA	H2020		2016	2020	Applied research		Spain	Joep Schyns	<a href="mailto:j.schyns@unizar.es">j.schyns@unizar.es</a>
12.14	MAGIC	Innovation Biofuels - Innovation Case	<a href="https://magic-nexus.eu/">https://magic-nexus.eu/</a>	RIA	H2020		2016	2020	Applied research		Spain	Mario Giampietro	<a href="mailto:mario.giampietro@unizar.es">mario.giampietro@unizar.es</a>
12.15	MAGIC	Innovation Electric Vehicle & Storage - Innovation Case	<a href="https://magic-nexus.eu/">https://magic-nexus.eu/</a>	RIA	H2020		2016	2020	Applied research		Spain	Louisa Jane Di Felice	<a href="mailto:louisajane.df@unizar.es">louisajane.df@unizar.es</a>
12.16	MAGIC	Innovation Environmental Protection - Innovation Case	<a href="https://magic-nexus.eu/">https://magic-nexus.eu/</a>	RIA	H2020		2016	2020	Applied research		Netherlands	Akke Kok	<a href="mailto:akke.kok@unizar.nl">akke.kok@unizar.nl</a>
12.17	MAGIC	Innovation Alternative Water Sources - Innovation Case	<a href="https://magic-nexus.eu/">https://magic-nexus.eu/</a>	RIA	H2020		2016	2020	Applied research		Spain	Baltasar Peñate	<a href="mailto:baltasarp@unizar.es">baltasarp@unizar.es</a>
12.18	MAGIC	Innovation Shale Gas Extraction - Innovation	<a href="https://magic-nexus.eu/">https://magic-nexus.eu/</a>	RIA	H2020		2016	2020	Applied research		Spain	Cristina Madrid	<a href="mailto:Cristina.Madrid@unizar.es">Cristina.Madrid@unizar.es</a>

Figure 3.Database in Table2

Table 1 shows the Questionnaire, created as an effective tool for expanding the current database of nexus case studies and development of content for the online nexus platform [8].

Table 1. Questionnaire with examples

CS <sup>7</sup> /PROJECT NUMBER	CS/PROJECT INFORMATION	CONTACTINFO/ COMMENTS	QUESTIONNAIRE TO COORDINATOR
3.NEXUS-NESS	YES (I inserted cs topic title)	NO for 2 coordinators. I filled in for others. YES?	Do you have the email addresses of CS coordinators within the NEXUS-NESS project? Salah M'hemdi (Tunisia)-email? Mohamed Bahnassy (Egypt)-email check? <a href="mailto:warredoc@unistrapg.it">warredoc@unistrapg.it</a>
15.BlueSCities	YES	NO <a href="#">[Website no longer working]</a> I filled in for 2 of 4 case studies. No contact information for Athens and Genova cs.	Do you have names and email address for Athens and Genova case study coordinators within the BlueSCities project? <a href="mailto:meleka@istanbul.edu.tr">meleka@istanbul.edu.tr</a>

#### 4. CONCLUSIONS

Within this paper, an overview of the development of two databases related to information on WEF NEXUS projects and case studies within them is presented. The Questionnaire is also presented as an effective tool for mapping and searching for missing data related to NEXUS projects and case studies. The results are presented with examples to better approximate the details related to the significant

<sup>7</sup>Case study

data on the projects and case studies. In the course of work, the methodology and framework for expanding the current database of nexus case studies and development of content for the online nexus platform was defined. The creation of the paper involved taking the following steps:

1. Multidisciplinary considerations of the WEF Nexus projects and case studies impacts,
2. In depth analysis of case studies and database documents (policies, planning, support, operation, performance evaluation, improvements, stakeholders),
3. Merging existing list of case studies and projects,
4. Populating the database in the platform.

The paper conceived in this way together with the presented methodological framework and results helps to better understand the importance of monitoring projects and case studies addressing NEXUS.

## ACKNOWLEDGMENTS

This research was financially supported by the Ministry of Science, Technological Development and Innovation of the Republic of Serbia (Contract No. 451-03-47/2023-01/ 200371). Part of this publication is based upon work from the COST Action <CA20138: Network on water-energy-food Nexus for a low-carbon economy in Europe and beyond – NEXUSNET>, supported by COST (European Cooperation in Science and Technology)

## REFERENCES

- [1] [https://nexusnet-cost.com/\(20.07.2023.\)](https://nexusnet-cost.com/(20.07.2023.))
- [2] [https://www.cost.eu/\(20.07.2023.\)](https://www.cost.eu/(20.07.2023.))
- [3] Vasović Dejan, Rađenović Tamara, Vranjanac Žarko, Živković Snežana: **WEF Nexus practical impacts as a “driver of change” in the field of environmental science transformation, innovation, and adaptation.** *International Conference CEMEPE&SECOTOX 2023*, Skiathos Island, Greece, 16-22, 2023.
- [4] Papadopoulou Chrysaída-Aliki, Papadopoulou Maria, Laspidou Chrysi: **Implementing Water-Energy-Land-Food-Climate Nexus Approach to Achieve the Sustainable Development Goals in Greece: Indicators and Policy Recommendations.** *Sustainability*, 14, 4100, 2022.
- [5] Papadopoulou Chrysaída-Aliki, Papadopoulou Maria, Laspidou Chrysi, Munaretto Stefania, Brouwer Floor: **Towards a Low-Carbon Economy: A Nexus-Oriented Policy Coherence Analysis in Greece.** *Sustainability*, 12, 373, 2020.
- [6] [https://www.sim4nexus.eu/userfiles/Deliverable\\_D5.5.pdf](https://www.sim4nexus.eu/userfiles/Deliverable_D5.5.pdf) (24.08.2023)
- [7] [https://nexogenesis.eu/\(24.08.2023\)](https://nexogenesis.eu/(24.08.2023))
- [8] <https://prima-nexus-ness.org>(24.08.2023)
- [9] <https://magic-nexus.eu/>(24.08.2023)

## INFLUENCE OF THERMAL INSULATION POSITION ON CONDENSATION IN THE WALL

Anka Starčev-Ćurčin<sup>1</sup>, Vesna Bulatović<sup>2</sup>, Tiana Milović<sup>3</sup>, Miloš Šešlija<sup>4</sup>

### Abstract

*Enhancing energy performance of existing buildings through retrofitting provides a great energy conservation opportunity in Republic of Serbia as buildings consume up to 40% of its annual total energy. Achieving sustainable building that is energy-efficient, environmentally friendly, and cost-effective depends on the material choices, construction methods and building systems. The basis of energy efficiency in buildings means lower energy consumption with providing comfort in the space intended for living. An important concept, in this meaning, is the building envelope, in which all components should work together and function in the right manner in order to achieve the intended goals. Even small mistakes in the performance of the building's energy rehabilitation can lead to a significant decrease in the planned energy efficiency and even a significant deterioration of the condition of the structural elements of the observed object. The main requirements, for accomplishment of these aims, are the use of quality materials with their proper placement. Placing thermal insulation as well as layers to protect against excessive moisture is quite a common practice today, but it is necessary to follow the principles of building physics and properly arrange the layers in the thermal envelope. The paper shows the importance of the correct position of the thermal insulation layer made of stone wool and EXP, also the vapor barrier, as well as the purpose of using the vapor barrier, through numerical examples of the external wall. The amount of water vapor retained inside the structural element was taken as a parameter. It has been shown that in the case of a wall, classic thermal insulation can be applied even on the inside (where it is usually not recommended), but with the proper use of a vapor barrier. It was also pointed out the lack of an accepted calculation that does not sufficiently take into account the characteristics of the material from the aspect of water vapor diffusion.*

**Key words:** energy efficiency, thermal insulation, vapor barrier, condensation

---

<sup>1</sup> PhD, Associate Professor, Faculty of Technical Sciences, University of Novi Sad, [astarcev@uns.ac.rs](mailto:astarcev@uns.ac.rs)

<sup>2</sup> PhD, Associate Professor, Faculty of Technical Sciences, University of Novi Sad, [vesnam@uns.ac.rs](mailto:vesnam@uns.ac.rs)

<sup>3</sup> PhD, Research Associate, Faculty of Technical Sciences, University of Novi Sad, [tiana.milovic@uns.ac.rs](mailto:tiana.milovic@uns.ac.rs)

<sup>4</sup> PhD, Assistant Professor, Faculty of Technical Sciences, University of Novi Sad, [sele@uns.ac.rs](mailto:sele@uns.ac.rs)

## 1. INTRODUCTION

It is already known that the building and construction industry are among the significant contributors to the green gas emission (according to some information 30%), energy consumption and waste worldwide. This primarily refers to the heating and cooling of the interior space due to the low energy efficiency of many residential buildings. If that trend continue, the buildings' energy consumption and green gas emission will be doubled by 2050 due to population and economic growth [1]. In all this, a significant contribution can be seen in energy efficiency of buildings because it is believed that they can make a significant contribution to reducing carbon dioxide emissions. There are two primary approaches towards sustainable and greener buildings. The first is the construction of new green buildings representing a key strategy to achieve urban sustainability by modifying the built environment. The second strategy is the sustainable energy retrofits of existing buildings as an almost more cost-effective and feasible alternative to new building construction [2].

The Law on Housing and Building Maintenance establishes the improvement of energy efficiency in buildings as a public interest in the Republic of Serbia. A survey of residential buildings showed that 85% of residential buildings in Republic of Serbia do not meet the minimum requirements for energy efficiency. This is mainly related to an insufficient building envelope, which leads to a significant loss of heat in winter and an increase in heat in summer. This leads to one of the priorities as improving the energy efficiency of these facilities both at the regional and national level. The current state of the housing stock shows that Serbia can achieve the greatest energy savings in the building sector. According to the Regulation for energy efficiency, in the Republic of Serbia, there are eight energy classes, from G as the worst energy class to A+ as the best energy class. When the new building is being built, it must be at least class C, while during reconstruction or rehabilitation, the class must be improved by at least for one degree [3]. If these conditions are not met, the observed building will not receive a use permit.

Achieving sustainable building that is energy-efficient, environmentally friendly and cost-effective depends on the material choices, construction methods and building systems. Great attention should be paid to the proper execution of works on improving energy efficiency in order to reach the appointed goal. Poor execution of works, in addition to not obtaining satisfactory results in terms of energy savings, can also lead to consequences that are harmful to health, such as excessive amounts of condensate and the appearance of unpleasant mold. Also, thermal insulation loses its properties in contact with moisture, vapor barriers are installed to prevent moisture to penetrate to the roof or to the wall thermal insulation. The relative resistance of water vapor diffusion for individual layers of the building element should continuously decrease from the inner to the outer surface, while at the same time the thermal resistance of individual layers should continuously increase. This aims to achieve a warm cross-section in which a smaller amount of moisture enters, but facilitates the diffusion of water vapor from the inside to the outside.

Attention should be paid to the method of calculation established by the Serbian Rulebook for Energy Efficiency and the Standard EN ISO 13788:2013. Actually, when calculating the diffusion of water vapor, the value of partial pressure is not taken into account as fully as it should be, but only the relative resistance to the diffusion of water vapor of certain material.

This paper shows the importance of the correct arrangement of thermal insulation material as well as vapor barrier, i.e. materials used as protection against excessive moisture. But also to a certain shortcoming of the principle of calculating the amount of condensate in the structural element.

## 2. SELECTED ASSEMBLIES FOR ANALYSIS

In order to show the importance of the correct placement of thermal insulation (TI), the changes that occur by changing the position of that material and due to the lack of condensation calculations, the appropriate external wall assemblies were selected. An assembly was chosen where stone wool was used as the thermal insulation material, then its position and its thickness was changed (5, 10, 20cm), vapor barrier was added, and then everything was repeated, but EXP was used instead of stone wool (layer marked with ' in the next assemblies). An overview of assemblies with selected materials and their characteristics is shown below:

*Assembly 1 (without vapor barrier, TI outside):*

	Material	Thickness	Other characteristics
1	TI mortar	$d=0.015m$	$\lambda=0.19W/mK$ ; $\mu=6$
2	Concrete	$d=0.25m$	$\lambda=0.76W/mK$ ; $\mu=6$
3	Stone wool	$d_A=0.05m$ ; $d_B=0.1m$ ; $d_C=0.2m$	$\lambda=0.035W/mK$ ; $\mu=1$
3'	EXP	$d_A=0.05m$ ; $d_B=0.1m$ ; $d_C=0.2m$	$\lambda=0.035W/mK$ ; $\mu=43$
4	Brick	$d=0.12m$ ;	$\lambda=0.64W/mK$ ; $\mu=9$

*Assembly 2 (without vapor barrier, TI inside):*

	Material	Thickness	Other characteristics
1	TI mortar	$d=0.015m$	$\lambda=0.19W/mK$ ; $\mu=6$
2	Stone wool	$d_A=0.05m$ ; $d_B=0.1m$ ; $d_C=0.2m$	$\lambda=0.035W/mK$ ; $\mu=1$
2'	EXP	$d_A=0.05m$ ; $d_B=0.1m$ ; $d_C=0.2m$	$\lambda=0.035W/mK$ ; $\mu=43$
3	Concrete	$d=0.25m$	$\lambda=0.76W/mK$ ; $\mu=6$
4	Brick	$d=0.12m$	$\lambda=0.64W/mK$ ; $\mu=9$

*Assembly 3 (vapor barrier inward, TI outside):*

	Material	Thickness	Other characteristics
1	TI mortar	$d=0.015m$	$\lambda=0.19W/mK$ ; $\mu=6$
2	Concrete	$d=0.25m$	$\lambda=0.76W/mK$ ; $\mu=6$
3	Vapor barrier	-	$Sd=5$
4	Stone wool	$d_A=0.05m$ ; $d_B=0.1m$ ; $d_C=0.2m$	$\lambda=0.035W/mK$ ; $\mu=1$
4'	EXP	$d_A=0.05m$ ; $d_B=0.1m$ ; $d_C=0.2m$	$\lambda=0.035W/mK$ ; $\mu=43$
5	Brick	$d=0.12m$	$\lambda=0.64W/mK$ ; $\mu=9$

**Assembly 4 (vapor barrier inward, TI inside):**

	Material	Thickness	Other characteristics
1	TI mortar	$d=0.015m$	$\lambda=0.19W/mK$ ; $\mu=6$
2	Vapor barrier	-	$Sd=5$
3	Stone wool	$d_A=0.05m$ ; $d_B=0.1m$ ; $d_C=0.2m$	$\lambda=0.035W/mK$ ; $\mu=1$
3'	EXP	$d_A=0.05m$ ; $d_B=0.1m$ ; $d_C=0.2m$	$\lambda=0.035W/mK$ ; $\mu=43$
4	Concrete	$d=0.25m$	$\lambda=0.76W/mK$ ; $\mu=6$
5	Brick	$d=0.12m$	$\lambda=0.64W/mK$ ; $\mu=9$

**Assembly 5 (vapor barrier to the outside, TI outside):**

	Material	Thickness	Other characteristics
1	TI mortar	$d=0.015m$	$\lambda=0.19W/mK$ ; $\mu=6$
2	Concrete	$d=0.25m$	$\lambda=0.76W/mK$ ; $\mu=6$
3	Stone wool	$d_A=0.05m$ ; $d_B=0.1m$ ; $d_C=0.2m$	$\lambda=0.035W/mK$ ; $\mu=1$
3'	EXP	$d_A=0.05m$ ; $d_B=0.1m$ ; $d_C=0.2m$	$\lambda=0.035W/mK$ ; $\mu=43$
4	Vapor barrier	-	$Sd=5$
5	Brick	$d=0.12m$	$\lambda=0.64W/mK$ ; $\mu=9$

wherein: d-layer thickness (m);  $\lambda$ -the coefficient of thermal conductivity (W/mK);  $\mu$ - water vapor diffusion resistance factor (-); Sd-water vapour diffusion/equivalent air layer thickness

The following data were selected for environmental conditions:

- internal temperature  $t_i=20^\circ C$
- outside temperature  $t_e=-5^\circ C$
- internal relative humidity  $\varphi_i=60\%$
- outside relative humidity  $\varphi_e=90\%$
- inside thermal resistance  $R_{s_i}=0.125m^2K/W$
- outside thermal resistance  $R_{s_e}=0.04 m^2K/W$

For each of the mentioned assemblies, a calculation of the density of the diffusion flow or condensation was made according to the EN ISO 13788:2013 [4]. The amount of water vapor retained inside the structural element was taken as a parameter for assessing the suitability of the layers.

### 3. EXPERIMENTAL RESULTS AND DISCUSSION

The layout of the selected assemblies and water vapor diffusion diagrams are shown in Figure 1-5. The amount of condensate in the structure are shown in Table 1.



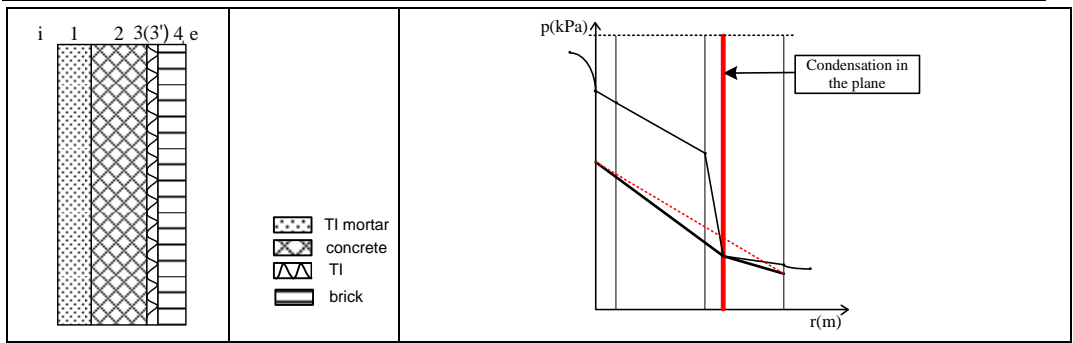


Figure 1. The assembly layout and water vapor diffusion diagrams in the assembly 1

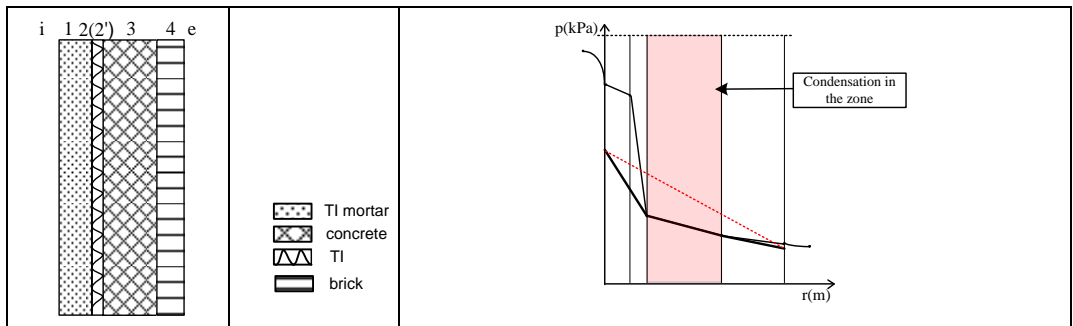


Figure 2. The assembly layout and water vapor diffusion diagrams in the assembly 2

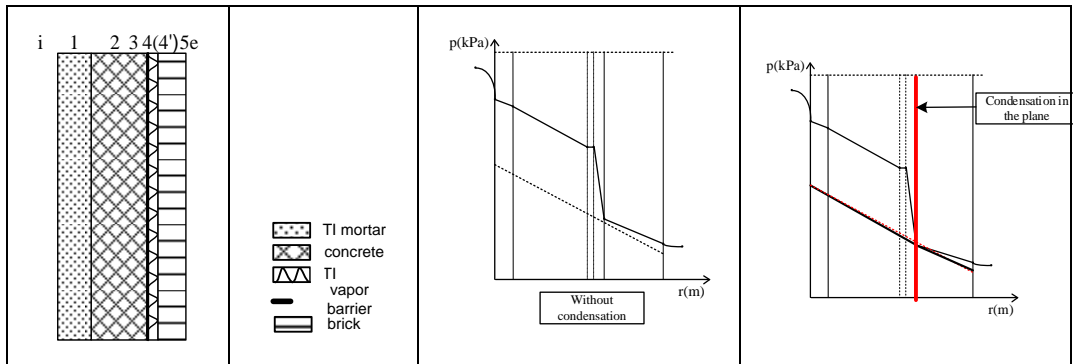


Figure 3. The assembly layout and water vapor diffusion diagrams in the assembly 3

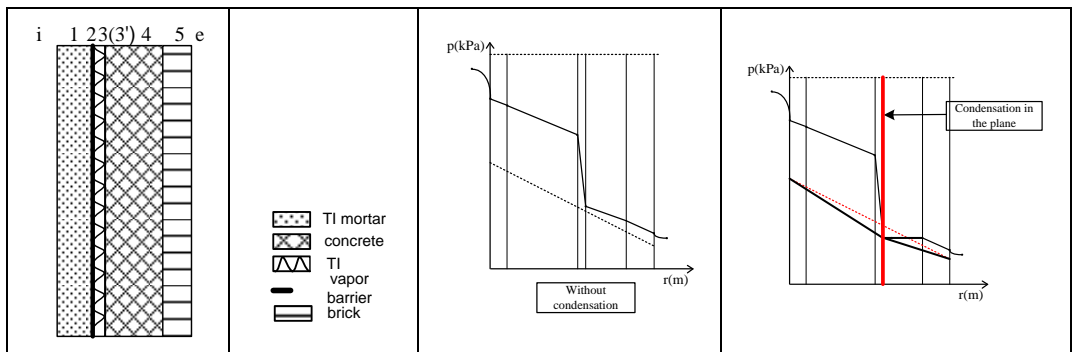


Figure 4. The assembly layout and water vapor diffusion diagrams in the assembly 4

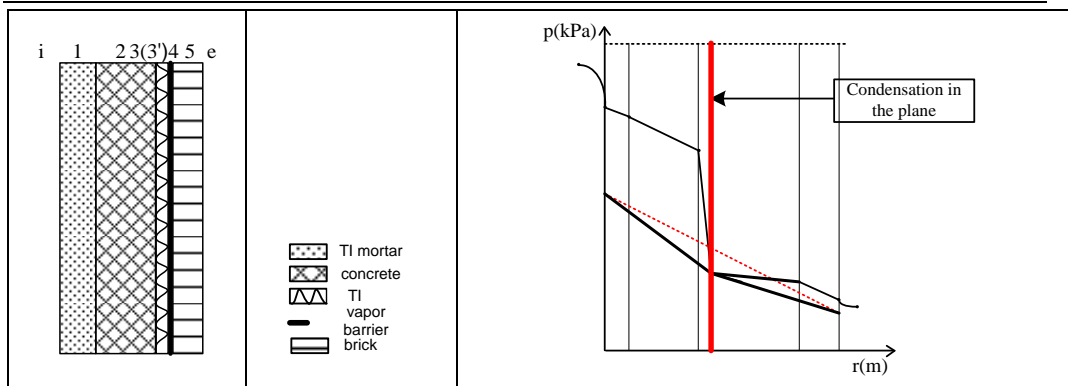


Figure 5. The assembly layout and water vapor diffusion diagrams in the assembly 5

Table 1. The amount of condensate in the assembly [g/m<sup>2</sup>h]

Assembly	Stone wool			EXP		
	d=0.05m	d=0.10m	d=0.2m	d=0.05m	d=0.10m	d=0.2m
1	0.261 (p)	0.289 (p)	0.294 (p)	0.070 (p)	0.042 (p)	0.018 (p)
2	3.135 (z)	2.714 (z)	1.930(z)	0.121 (z)	0.063 (z)	0.024 (z)
3	0	0.030 (p)	0.047 (p)	0	0	0
4	0.011 (p)	0.055 (p)	0.067 (p)	0	0	0.013 (p)
5	0.338 (p)	0.335 (p)	0.294 (p)	0.135 (p)	0.081 (p)	0.051 (p)

wherein: z-condensation in the zone; p- condensation in the plane

According to the assemblies that are presented in this paper, it can be concluded that the best place to install thermal insulation is confirmed, as close as possible to the outside environment. In the case of assembly 1, regardless of whether it is stone wool or EXP is used, a relatively small amount of condensate formed inside the wall was achieved. The situation, in this case, could be further improved, in terms of the absence or extremely small amount of condensate, by the use of a vapor barrier placed towards the inside (assembly 3 with the amount of condensation almost 0 g/m<sup>2</sup>h). It can also be seen that the situation will not change significantly if, along with the application of thermal insulation, a vapor barrier is placed on the outside (assembly 5). In that case, the vapor barrier loses its meaning. This conclusion is valid regardless of whether stone wool or EXP is used, and when all three thicknesses of materials are selected (5, 10 and 20cm).

In some situations, thermal insulation is simply unavoidable and is placed from the inside. In that case, it is observed that from the perspective of the amount of condensate, this is the most unfavorable case when we use stone wool. Meanwhile, in this case, the situation can be improved by adding a vapor barrier to the inside of the wall, where the condensation amount is significantly reduced. In the case of the application of the EXP, this is not so emphasized, which is very interesting. The resistance to diffusion of water vapor in the case of EXP is significantly higher than the same coefficient in the case of stone wool (43 compared to 1), which would mean that the former is less favorable in terms of the appearance of condensation, which in these situations and applying the calculation given in the standard EN ISO 13788 did not show.

According to the water vapor diffusion diagrams, it can be noticed that for most of the selected situations, condensation occurs in the plane and the pressure differences can almost be ignored.

Based on the different thicknesses of the thermal insulation layer made of stone wool or EXP (5, 10 and 20cm), it can be seen that in all cases, except for case 2, there is a insignificant increase in the amount of condensate with the increase in the thickness of the thermal insulation layer. Thereby, it can be concluded that in the case of stone wool or EXP application, the thickness of the thermal insulation layer does not have a significant contribution in amount of condensation calculated according to the procedure given in EN 13788. This is true for all cases except in case 2, when TI is installed from the inside without applying a vapor barrier.

#### 4. CONCLUSION

Based on the analysis of the selected assemblies, the type (stone wool and EXP) and different thicknesses of the thermal insulation layer (5, 10 and 20cm), the following can be concluded:

It is better to place the thermal insulation layer as close as possible to the outside in order to reduce or completely avoid the amount of condensation.

If the thermal insulation layer is placed closer to the outside of the wall, the amount of condensate can be reduced by adding a vapor barrier closer to the inside. If the vapor barrier is placed closer to the outside, it will have no effect on the amount of condensation, i.e barrier loses its importance.

If the thermal insulation layer of stone wool is placed on the inside without applying a vapor barrier, the largest amount of condensate is obtained and that assembly is not acceptable according to the regulations in terms of drying time. The situation is significantly improved by adding a vapor barrier to the inside of the wall. However, this is not valid for EXP, although from the aspect of water vapor permeability, EXP is significantly less favorable than stone wool. To some extent, this can be attributed to the imperfection of the accepted calculation for the diffusion in the structural assembly.

Based on this, it can be concluded that in the case of stone wool or EXP application, the thickness of the thermal insulation layer does not have a significant contribution in amount of condensation calculated according to the accepted procedure.

#### ACKNOWLEDGMENT

The research has been conducted within the project "Scientific theoretical and experimental research and improvement of educational process in the field of civil engineering", developed at the Department of Civil Engineering and Geodesy, Faculty of Technical Sciences, University of Novi Sad, Serbia.

#### REFERENCES

- [1] Motalebi Maedeh, Rashidi Ali, Mahdi Nasiri Mohammad: **Optimization and BIM-based lifecycle assessment integration for energy retrofit of buildings.** *Journal of Building Engineering* 49, 104022, 2022.
- [2] Zhang Hongru, Liu Wenshen, Zhang Jingbo, Liu Fujiang, Lin Xujian, Ji Tao: A new look at the resistance of recycled aggregate concrete (RAC) to the external

sulfate attacks: The influence of the multiple mesoscopic material phases. *Journal of Building Engineering*, 64, 105653, 2023.

- [3] Li Yang, Zang Xianbing, Lou Peng, Wang Ruijun, Li Yanlong, Si Zheng: **Sulfate attack resistance of recycled aggregate concrete with NaOH-solution-treated crumb rubber**. *Construction and building materials*, 287, 123044, 2021.
- [4] EN ISO 13788:2013: Hygrothermal performance of building components and building elements - Internal surface temperature to avoid critical surface humidity and interstitial condensation - Calculation methods, Institute for Standardization of Serbia.

# ENERGY EFFICIENCY OF BUILDINGS IN SERBIA - SOME PERSONAL EXPERIENCES FROM THE PROCESS OF DESIGN AND REALIZATION

Aleksandar Rajčić<sup>1</sup>

## Abstract

*Current, innovative regulations on energy efficiency of buildings, have been present in Serbia for past 11 years.*

*In that interval, a lot has changed in the processes of design, construction and exploitation of buildings, compared to the period before 2012.*

*Some of the personal experiences, both positive and negative, will be presented here, with the desire to exchange information.*

*Based on the designed around 2 million square meters of space for various purposes, as a responsible designer of energy efficiency, participation in several scientific projects in this area, as well as the realization of a number of specialized software in the field of energy efficiency of buildings, some observations can be presented, and some proposals for the improvement of both the regulations and the control of project documentation, as well as control procedure, can be given.*

*In the context of the demanding number and diversity of relevant projects, we will also talk here about software tools that were developed specifically for use in the process of creating documentation, i.e. Energy efficiency studies, as well as energy certificates, with special reference to KnaufTerm3D, a unique program for modelling and calculation of energy characteristics of buildings.*

*Energy certification of new buildings, or buildings that are reconstructed, adapted, or extended, is a procedure that is well known, and is included in the process of obtaining a use permit of building. It has its good and bad sides, and some of them will be explained.*

*In addition, in this paper we will also talk about the energy certification of apartments, in the light of the upcoming legal obligation in the processes of real estate transactions, from the aspect of possibilities and limitations.*

**Key words:** *Energy efficiency, Energy certification, Serbia, Software, KnaufTerm3D*

---

<sup>1</sup> PhD, Associate Professor, architect, rajcic@arh.bg.ac.rs

## 1. INTRODUCTION

Here, some phenomena and problems that can be encountered in professional work in Serbia will be listed and explained.

The observations in this paper are based on independent work as a responsible designer of energy efficiency (hereinafter referred to as an EnEf designer), in the process of designing and creating technical documentation, in accordance with domestic regulations [1], [2].

Although according to our regulation, Elaborate of Energy Efficiency of Buildings<sup>2</sup> (hereafter referred to as an EnEf Elaborate) are not subject to technical control [3 (Articles 58 and 76)] in certain projects, of greater importance, based on the investor's request, controls were carried out, and a review will be given in connection with those results.

The moment of inclusion of the EnEf designer in the architectural design process is not strictly defined in the regulations. Bearing in mind that today, in our country, except for the projects defined by legal acts (conceptual solution, preliminary project, project for building permit, project for execution and project of the finished state), under the influence of foreign investors, i.e. the practice that was transferred from other countries, there are also hybrid forms of projects, when e.g. it is necessary to prepare precise tender documentation even in the conceptual design phase, it is clear that the need for information related to the field of energy efficiency appears practically at the very beginning of the design process.

This need is particularly pronounced if the process of contracting the construction, that is, the sale of built-up space, most often of the residential type, takes place in these early stages of design. It is not a rare case that even then the exact area of the space, for example the apartment that is being sold, is defined and that, regardless of the other phases of the project, such a value must not be deviated from. This unequivocally opens the problem of precision in defining dimensions, primarily in the horizontal plane, that is, the thicknesses of facade wall structures, partition walls towards corridors and staircases, between apartments, etc.

Therefore, one of the first questions that the EnEf designer encounters, and which the architectural designer asks him, is: "what is the required thickness of the insulation, or the total thickness of one of the walls?". This is especially pronounced in buildings with a large area, i.e. high-story buildings, because every cm saved on the thickness of one of the walls is multiplied by the corresponding length and number of floors, which is directly reflected in the price, i.e. profit, or its reduction. So, it is a "big numbers game".

## 2. NEW BUILDINGS DESIGNING AND CALCULATION

It can be said that today, in the design and implementation of new buildings, professionals, and in large part investors, have, after 11 years of work, "learned" how and what should be designed so that the results are in accordance with the regulations.

In this sense, it is most important at the very beginning of the work to determine with the project assignment (signed) whether the building should only meet the basic

---

<sup>2</sup> Sometime it is translated as Energy Efficiency Report (EnEf Report)

requirements of the energy certification (C energy class) or if stricter requirements should be set (e.g. B energy class).

And in practice, this is a rather rare case, because very often the work is started without a project assignment or it is incomplete, or the investor does not want to make a statement about it. It is clear that the designers have to work, regardless of the lack of all, including this very important information, and in that case it is designed with the assumption that the minimum required conditions (C energy class) will be met.

It is not a rare case that near the end of the work, or even more often, after the end of the work (e.g. in the stage of drawing up the project for the permit), the investor changes his mind and sets the goal that the building should be, for example, B energy class. Such a change of attitude is very often inspired by marketing reasons, i.e. opportunities for easier and better sales (e.g. of apartments). It is often not easy for designers, and especially the EnEf designer, to comply with this wish, because there is a limited number of additional interventions with which it is possible to improve the energy rating:

- By designing thermally better windows / balcony doors / curtain walls, with e.g. with a three-layer glass package, instead of the so far designed two-layer one. This is also the most realistic option, which of course should be checked from the financial aspect - how much it will cost the investor.
- As a rule, intervention on the facade walls is out of the question, because with each thickening of the facade thermal insulation, the ratio of gross to net square footage changes, which must not be allowed in projects for permission.
- Intervention on the internal walls towards the unheated space (e.g. corridor, staircase) is mostly out of the question, because these spaces are already designed in accordance with the minimum required dimensions (evacuation route width), so any thickening of such walls is not realistic.
- Potential positions for improvement are roofs and structures above garages (unheated or external), because the surface is not disturbed by thickening the thermal insulation or changing the material (e.g. PIR instead of XPS). Additional interventions in these positions contribute very little to the overall balance, because they had to be designed to meet the very strict  $U_{max}$  criteria at the very start anyway.

These are the enumerated criteria, from the aspect of honest professional work. However, it is not at all a rare case, which could be established through the technical control of some projects, that the designer of EnEf, most likely under pressure (of investors), resorted to calculation manipulations, in order to fulfill expectations regarding the energy class. Here we are talking about deliberate mistakes, which are mainly focused in the following dominant segments:

- The useful heated surface is shown and calculated as larger than it really is, which reduces the specific need for energy, and in the end a better (lower) result is obtained
- The net volume of the heated/ventilated space is displayed and calculated as less than it actually is. This directly results in lower ventilation losses, i.e. lower energy required for heating and a better final result (better energy class).

- Smaller partial areas of the position of the thermal envelope than they really are. This also reduces the energy required for heating
- An over-optimistic scenario for solar heat gains. Often inadequately high values of correction factors are adopted that affect the calculation of solar gains, not respecting (accidental or intentional) shading from parts of the building, the influence of shading equipment, etc. This results in abnormally large solar gains, which in the transition months (in Belgrade, October and April), negate the need for any heating. At first glance, this does not seem wrong, but it is fundamentally incorrect, because solar gains cannot be stored (without special equipment that is never used) for a period when the sun is not present. In addition, the heated season continues in those months, heating exists, heating plants work and deliver energy. All this results in a reduction of the required annual energy for heating and an often unrealistic improvement in the energy class
- Only the result valid for heating systems operating with a (night) interruption in heating is displayed. Very often, when the result is on a "seesaw", a more favorable energy class (e.g. B class) is obtained when interruptions in operation are calculated, and a less favorable one (e.g. C class) when calculating with continuous heating. In practice, there is a divided opinion on the presentation of these phenomena, because even in the regulations, the instructions are not entirely clear, which opens the possibility for different interpretations. In some cases, when the object is not designed to be connected to the district heating system (which has its own working hours), abuses can also be encountered in the control process regarding the length of interruptions in the operation of the heating system, where unrealistically long interruptions give a favorable result in energy needs.

### 2.1. Geometry problem

From the above, it can be seen that most of the potential "errors" in the calculation are caused by incorrect values related to the geometric characteristics of the object:

- Surface and partial surfaces (according to the sides of the world) position of the thermal envelope
- The surface of the heated space
- By the volume of the heated space and, secondarily, by the gross volume

And here we can talk about the "game of big numbers", because the values of areas and volumes are big numbers, in the amounts of several hundreds, or thousands or tens of thousands, which compared to other input parameters, such as the coefficients of U positions, which are extremely small numbers, mostly smaller than 1, or close to it, i.e. correction factors  $F_x$ , which are also small numbers, values of 1 or smaller, gives a clear picture of where to "hunt" for the problem. The dominant practice so far is to know very well the thermal characteristics of each position, one could solve "to the third decimal place", and insufficient attention is paid to the geometrical characteristics.

In addition, the calculation of geometric characteristics (area and volume) is a annoying and time-consuming process, which cannot be automated and simplified even by using standard BIM tools.



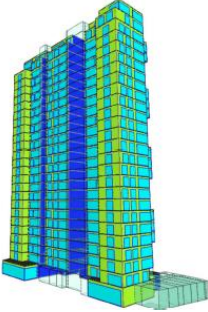
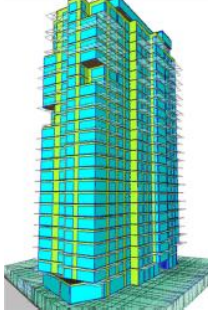
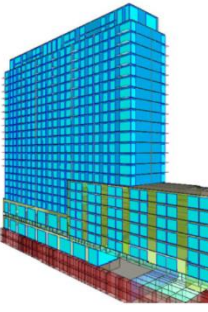
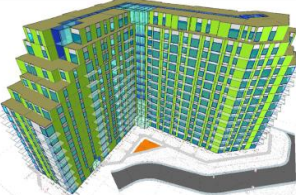

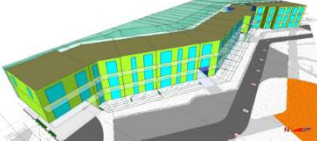
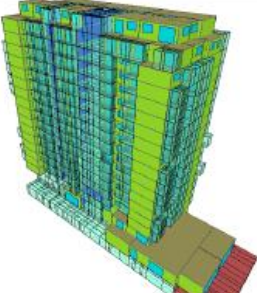
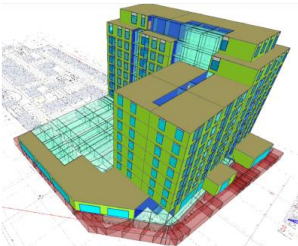

### 3. SOFTWARE KNAUFTERM3D

Because of the above, we designed and developed the KnaufTerm3D software - a tool for modeling and calculation, in accordance with the regulations of Serbia.

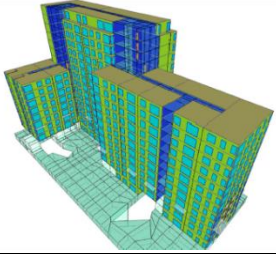
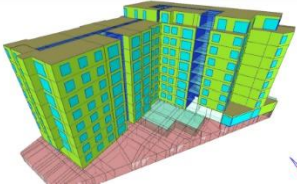
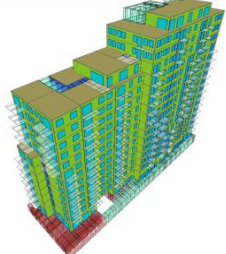

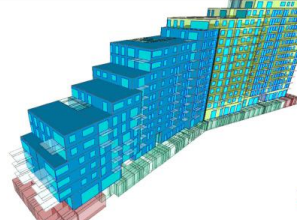

We have been used KnaufTerm3D in professional work for the past four years, for the design of over 1.5 million m<sup>2</sup> of space of various uses.

The table below shows some of the residential buildings (3D model and results<sup>3</sup>).

Table 1 -An overview of case studies of new buildings

		
<i>Residential, <math>A_H = 21530 \text{ m}^2</math> <math>Q_{h.an} = 42.26 \text{ kWh/m}^2</math>, <b>C class</b></i>	<i>Residential, <math>A_H = 24054 \text{ m}^2</math> <math>Q_{h.an} = 43.38 \text{ kWh/m}^2</math>, <b>C class</b></i>	<i>Residential, <math>A_H = 23363 \text{ m}^2</math> <math>Q_{h.an} = 36.06 \text{ kWh/m}^2</math>, <b>C class</b></i>
		
<i>Residential, <math>A_H = 18481 \text{ m}^2</math> <math>Q_{h.an} = 39.09 \text{ kWh/m}^2</math>, <b>C class</b></i>	<i>Residential, <math>A_H = 16614 \text{ m}^2</math> <math>Q_{h.an} = 37.94 \text{ kWh/m}^2</math>, <b>C class</b></i>	<i>Residential, <math>A_H = 2202 \text{ m}^2</math> <math>Q_{h.an} = 42.82 \text{ kWh/m}^2</math>, <b>C class</b></i>
		
<i>Residential, <math>A_H = 14342 \text{ m}^2</math> <math>Q_{h.an} = 38.18 \text{ kWh/m}^2</math>, <b>C class</b></i>	<i>Residential, <math>A_H = 8419 \text{ m}^2</math> <math>Q_{h.an} = 42.67 \text{ kWh/m}^2</math>, <b>C class</b></i>	<i>Residential, <math>A_H = 10242 \text{ m}^2</math> <math>Q_{h.an} = 39.04 \text{ kWh/m}^2</math>, <b>C class</b></i>

<sup>3</sup> Dominant function /  $A_H$  (Heated Area) /  $Q_{h.an}$  (Quantity of Energy for Heating, annually) / Energy class

		
<i>Residential, <math>A_H = 18118 \text{ m}^2</math> <math>Q_{h.an} = 39.92 \text{ kWh/m}^2</math>, <b>C class</b></i>	<i>Residential, <math>A_H = 7919 \text{ m}^2</math> <math>Q_{h.an} = 43.00 \text{ kWh/m}^2</math>, <b>C class</b></i>	<i>Residential, <math>A_H = 12254 \text{ m}^2</math> <math>Q_{h.an} = 39.90 \text{ kWh/m}^2</math>, <b>C class</b></i>
		
<i>Residential, <math>A_H = 14112 \text{ m}^2</math> <math>Q_{h.an} = 40.07 \text{ kWh/m}^2</math>, <b>C class</b></i>	<i>Residential, <math>A_H = 6760 \text{ m}^2</math> <math>Q_{h.an} = 41.72 \text{ kWh/m}^2</math>, <b>C class</b></i>	<i>Residential, <math>A_H = 94.29 \text{ m}^2</math> <math>Q_{h.an} = 39.69 \text{ kWh/m}^2</math>, <b>C class</b></i>

#### 4. EXISTING BUILDINGS DESIGNING AND CALCULATION

Things are a bit more delicate when we talk about the process of adaptation or reconstruction of existing buildings. In the Rulebook on Energy Efficiency of Buildings, the legislator made a distinction between new and existing buildings, so that for existing buildings that, for example, reconstruct, apply somewhat milder criteria regarding the maximum permitted heat transfer ( $U_{max}$  coefficient).

In addition, an (unwritten) principle was established, that in the process of reconstruction or adaptation, not every position must be brought "in order", that is, it must comply with the prescribed  $U_{max}$  coefficient. It is important that the building as a whole be improved by at least one energy class [2, Article 10, paragraph 5]. This means that the work becomes more complicated and that there is often twice as much work as when designing a new building.

It is necessary to first prepare the Elaborate EnEf for the existing state, and then the Elaborate EnEf for the new (designed) state. A comparison of the results of the energy certification is made, and it is necessary to achieve the mentioned improvement of at least one energy class.

What the legislator did not initially recognize as a problem, and what turned out to be unresolved during the work, relates to the required maximum level of improvement. If an object is subject to intervention more than once, e.g. twice, in some period, it would be necessary to improve at least one grade in each iteration. This is not logical, because if the minimum condition is defined for new buildings that the building must be at least in the C energy class, why would someone "force" that the old building be better than the new one.

In this sense, the Ministry of Construction and Urban Planning on 25.03.2013. issued an interpretation under number 110-00-00015/2013-04, where in paragraph 5, among other things, it is stated:

"If, based on the calculated energy needs and the energy survey and the issued energy passport, it is proven that the existing building is classified in class "C", then it is not necessary to increase the energy class of the existing building..."

This attitude is also very helpful when making a decision on whether an Elaborate EnEf of the existing state is really needed, because if the designed interventions show that the building will be certified at least in the C energy class, then it is irrelevant what class it was before. This particularly facilitates the design process itself, because often not all data on the existing condition, i.e. the thermal characteristics of the envelope positions, are known.

Bearing in mind the above, the architectural designer as well as the EnEf designer make a decision on which positions of the thermal envelope will be subject to intervention.

The "most painless" for them is focusing on transparent positions (windows, shop windows, curtain wall), because it is always expected to change or improve them first. Then it's time for roofs (flat or sloping), because this can usually be done without major problems, either in terms of dimensional fit or in terms of availability.

The most delicate issue is the facade walls. From the aspect of building physics, it is ideal that the subsequent thermal insulation is placed on the outside, but in practice the following problems can be encountered:

- The building is under protection, e.g. of the Institute for the Protection of Cultural Monuments, and external interventions are prohibited.
- The building is not under any protection regime, but a problem arises at the local administrative (municipal or city) level, when the competent service for issuing approvals interprets the legal provisions restrictively and considers that the installation of external layers (thermal insulation and protection layer) changes the gross area of the building, disturbs the "construction line" and the like. This is in direct conflict with the provision from the Rulebook on EnEf [1], article 2, sub 3c, which states: "The gross construction area does not include areas within the system of double facades, greenhouses, areas that make up the thermal envelope of the building. In the case of heterogeneous walls, the thermal insulation thickness of more than 5 cm is not included in the gross developed construction area, and in the case of homogeneous walls, the wall thickness is greater than 30 cm..."

#### **4.1. Historic And Preserved Buildings**

Buildings that are under some of the protection regimes are specific, because from an architectural point of view, no intervention may be done from the outside. In certain cases, if it is necessary (for reasons of rehabilitation), the intervention should be such that the original appearance is preserved.

Cultural goods, depending on their importance, are classified into categories:

- Protected cultural goods,
- Cultural goods of great importance and
- Cultural assets of exceptional importance.

#### 4.1.1. Facade – Non-Transparent Parts

As for the solid (opaque) part of the facade wall, this results in making a decision in the following options:

- Any intervention will not perform on the facade wall, neither outside nor inside. It will be consciously assumed that the facade wall will not meet the  $U_{max}$  conditions, and the necessary energy improvement will be realized by intervention on other parts of the thermal envelope. This option has the effect of not changing the net surface area of the interior, nor does it affect the possible distribution of installations network (e.g. heating).
- Intervention will be carried out from the inside. This is a potential problem because:
  - The net area of the interior is reduced
  - The installation network (e.g. heating equipment) must be moved
  - Due to the inverse concept of placing the layers (thermal insulation is now on the inside), the thermal mass of the wall is reduced or completely lost, i.e. thermal inertia
  - Diffusion, condensation and drying problems can occur if vapor barrier layers are not well designed or executed
- The existing facade covering (if it cannot be simply repaired) is removed and a new one is installed, which will imitate the existing architectural and artistic solution. As part of this new facade cladding, a thermal insulation layer will be installed. It is clear that in this case the thickness of the facade increases, which opens up the previously mentioned problem of the gross area.




#### 4.1.2. Facade – Transparent Parts



Replacing windows (on protected facades) is not an entirely simple process. In certain cases, the conditions for reconstruction are extremely restrictive, and new windows must be designed so that they fully match the existing ones, both in terms of material and geometric characteristics. In extreme cases, it is not possible to imitate the external appearance (with reasonable costs), so a hybrid solution is resorted to: the outer part of the frame and the outer wing are kept, and on the inside, a modern part of the frame with the wing, glazed with a double or triple-layer glass unit, is designed.

## 4.2. Case Studies

Several projects were designed, and some of them are presented in the table below:

Table 2 -An overview of case studies of interventions on existing buildings

<b>Stari dvor (Old Palace) in Belgrade</b>	
	<p><i>Interventions:</i></p> <ul style="list-style-type: none"> <li>- Partly new windows, partly composite (existing exterior wing, new internal wing &amp; glazing)</li> <li>- New skylight</li> </ul>
<p><i>Before interventions:</i>  <math>Q_{h,an}=104.76 \text{ kWh/m}^2</math>, E class</p>	<p><i>After interventions:</i>  <math>Q_{h,an}=85.34 \text{ kWh/m}^2</math>, D class</p>
<b>Hotel "Bristol" in Belgrade</b>	
	<p><i>Interventions:</i></p> <ul style="list-style-type: none"> <li>- New windows</li> <li>- Internal facade insulation</li> <li>- Roof insulations</li> <li>- Slab over basement insulation</li> </ul>
<p><i>Before interventions:</i>            Irrelevant</p>	<p><i>After interventions:</i>  <math>Q_{h,an}=44.52 \text{ kWh/m}^2</math>, B class</p>
<b>Railway station in Belgrade</b>	
	<p><i>Interventions:</i></p> <ul style="list-style-type: none"> <li>- New windows</li> <li>- New skylight</li> <li>- Slab beneath attics insulation</li> </ul>
<p><i>Before interventions:</i>  <math>Q_{h,an}=100.98 \text{ kWh/m}^2</math>, C class</p>	<p><i>After interventions:</i>  <math>Q_{h,an}=71.51 \text{ kWh/m}^2</math>, C class</p>

<b>Hotel "Park" in Belgrade</b>	
	<p style="text-align: center;"><i>Interventions:</i></p> <ul style="list-style-type: none"> <li>- <i>New windows</i></li> <li>- <i>Internal facade insulation</i></li> <li>- <i>Roof insulations</i></li> <li>- <i>Slab over basement insulation</i></li> </ul>
<p><i>Before interventions:</i> <i>Irelevant</i></p>	<p><i>After interventions:</i> <i>Qh<sub>.an</sub>=45.77 kWh/m<sup>2</sup>, B class</i></p>
<b>State authorities building, Belgrade</b>	
	<p style="text-align: center;"><i>Interventions:</i></p> <ul style="list-style-type: none"> <li>- <i>New windows</i></li> <li>- <i>External facade insulation (including new facade stone cladding)</i></li> <li>- <i>Roof insulations</i></li> <li>- <i>Slab over basement insulation</i></li> </ul>
<p><i>Before interventions:</i> <i>Irelevant</i></p>	<p><i>After interventions:</i> <i>Qh<sub>.an</sub>=41.84 kWh/m<sup>2</sup>, C class</i></p>

## 5. ENERGY CERTIFICATE

Energy certificate, or colloquially energy passport<sup>4</sup>, is a document that is mandatory for all new buildings that need to receive a use permit [2].

### 5.1. Energy Certificate Of Building

It can be done by legal entities that have the appropriate license and have employed at least 2 full-time EnEf designers with license 381 [2, Articles 4 and 5]. Such strict working conditions do not mean that the accuracy of these documents has been improved. Malfunctions can be observed, sometimes dramatic ones. Although the legislator was very restrictive on the issue of obtaining permission for the production of certificates, he did nothing on the process of controlling these documents. In Serbia, there is no control authority or professional body that checks the accuracy of these documents. In other countries (EU), there are professional authorities, which use the method of random sampling to control from the national data base, and in case of inaccuracy or abuse, impose high fines and ban work.

The absence of a control mechanism in Serbia leads to certain dramatic cases, which often end up in court.

<sup>4</sup> Remark of the author: An inappropriate term, because the building "doesn't travel anywhere"

A negative example will be cited here, when the Investor of residential buildings in a city in Vojvodina entrusted the production of an energy "passport" to our well-known company in the field of building chemistry. The designer EnEf made a huge error in the calculation, which no one noticed (because there is no control process), which incorrectly certified the buildings in the A+ energy class. As such, attractive for marketing purposes, they were put on the market, customers bought apartments, and some of them, after the initial period of exploitation, stated that not only were the heating costs not low, as the investor had promised, but also that there were structural damages in the interior (condensation and moulding) due to poorly done works. This was also the basis for initiating court proceedings [5].

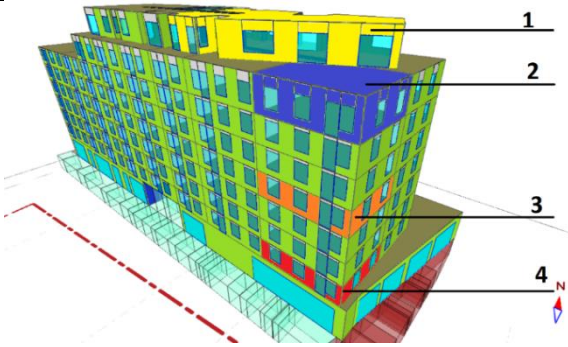
## 5.2. Energy Certificate Of Apartment

An energy certificate can also be issued for a functional unit [2, article 16, paragraph 3], e.g. apartment or business premises. In the context of the announced changes in the process of sale and purchase of real estate, this becomes binding, which may have serious implications in practice, first of all due to the expected volume of transactions, it is clear that the legal entities that were previously licensed to produce certificates will not have enough capacity, and due to restrictive licensing conditions, and it is assumed that, in this sense, a solution will have to be sought on more lenient conditions for licensing legal entities, including entrepreneurs.

Among other things, the KnaufTerm3D program is designed to define special functional units, with appropriate characteristics, way of use, etc., during the creation of a 3D model. This means that the energy characteristics of each functional unit (apartment, office space) in a building can be determined very simply, including the energy certificate.

Based on these procedures, it is possible to compare the characteristics of apartments in the same building, because differences in the microlocation of the apartment, horizontal or vertical position, orientation, etc., can cause significant differences in the energy rating. Based on a large number of analyzed cases, and one of them is presented in the table bellow, it can be concluded that apartments in attics (top floors) have the worst energy class, followed by apartments above open passages or garages, and that apartments closer to the center of the building are in a better situation.

Table 3 - Case studie of energy certification of apt.units, regarding position in building

		QH.an [kWh/m <sup>2</sup> ]	En. class
	Whole Building	42.96	<b>C</b>
	Apartment num.		
	1	72.71	<b>D</b>
	2	50.25	<b>C</b>
	3	29.89	<b>B</b>
4	30.37	<b>C</b>	

The difference between the results can go from 1 to 2 energy classes. This seems somewhat paradoxical: the building as a whole is satisfactory (C energy class), and some of its parts / apartments are not satisfactory (D energy class), while some are extremely well ranked (B energy class).

Such results are quite expected and logical, because it is intuitively known that centrally located apartments are more protected than peripherally located ones. Analysis of this type can also help in making a decision when buying new apartment.

## 6. CONCLUSION AND SUGGESTIONS

In order to improve the accuracy of calculations and eliminate noticed problems, it is suggested:

- Mandatory technical control of Elaborate EnEf
- Mandatory control of energy certificates
- Forming an expert control body at the state level for the purposes of validating energy certificates
- Abolition of restrictive conditions for obtaining a license for the production of energy certificates (two full-time engineers with license 381) in order to increase professional capacities for the needs of the announced energy certification of apartments and business premises in the real estate transaction process. It is suggested that every engineer with a 381 license, who is insured against professional errors through, can make and verify an energy certificate.

## REFERENCES

- [1] **Rulebook on energy efficiency of buildings**, "Official Gazette of RS" No. 61/2011
- [2] **Rulebook on the conditions, content and manner of issuing certificates on the energy properties of buildings**, "Official Gazette of RS" No. 69/2012
- [3] **Rulebook on the content, method and procedure of preparation and method of control of technical documentation according to the class and purpose of facilities**, "Official Gazette of RS" No. 23/2015, 77/2015, 58/2016, 96/2016 and 67/2017
- [4] Rajčić Aleksandar and Rajčić Uroš, **Software KnaufTerm3D**, "Arhitektura i energija", available on <https://www.knaufinsulation.rs/knaufterm3d>
- [5] <https://youtu.be/VfW5OKVknQ4>
- [6] Journal article: Rajčić Aleksandar, "Energetski sertifikati zgrade vs energetski sertifikati stana", *GRENEF*, num.21, 2023., pg.108-113, ISSN 2560-5984, COBISS.SR-ID 321750279, [www.grendef.com](http://www.grendef.com)

**Note:** Professional projects that are the source of information are not referenced in this paper



# ASSESSMENT OF THE QUALITY OF HOUSING STOCK IN BELGRADE ACCORDING TO ENERGY CONSUMPTION

Ljiljana Đukanović<sup>1</sup>

## Abstract

*Assessing the housing quality of existing residential buildings is always a topical issue for research, because the built housing stock is a constantly growing resource whose structure, quality of construction, and compliance with modern housing requirements, largely define housing comfort. On the other hand, modern society recognizes that energy savings are a prerequisite for responsible behavior towards future generations, which, given the dominant consumption in the field of housing, puts the focus on the residential buildings stock. Given the fact that numerous buildings that make up the housing stock of Belgrade were built at a time when there were no regulations on thermal insulation and in most cases no energy improvements were made, we can talk about a significant resource that "wastes" energy whose renovation can lead to significant energy savings. The paper will analyze model buildings, which by their structural characteristics represent characteristic periods of construction of residential buildings, and based on the obtained data, conclusions will be made about the quality of the housing stock from the point of view of energy consumption.*

**Key words:** *housing stock, energy consumption, thermal comfort*

---

<sup>1</sup> Ph.D, Associate professor, University of Belgrade Faculty of Architecture, djuli@arh.bg.ac.rs

## 1. INTRODUCTION

The need for energy reconstruction of existing buildings has been a concern of experts in energy savings for many years, given their high percentage contribution to total energy consumption. Buildings are responsible for 40% of the total energy consumption in the EU and 36% of harmful gas emissions. However, the percentage of building renovations at the European Union level remains very low, as shown by data published in the 2020 strategy 'A Renovation Wave for Europe' [1]. Alarming data about the state of the European building stock were presented, emphasizing the necessity of intensifying its renovation in order to achieve carbon dioxide neutrality by 2050, a major goal set by the European Green Deal [2]. It was highlighted that the European building stock is highly heterogeneous and old, with 85% of buildings (220 million structures) built before 2001 and 35% of them being older than 50 years (built before 1970). About 75% of the existing EU building stock is not energy-efficient. Only 11% of the building stock undergoes any level of renovation annually, with only 1% of these renovations focusing on improving energy efficiency. The European Commission initiated the Renovation Wave strategy precisely to stimulate the necessary changes required to reduce overall energy consumption and carbon dioxide emissions [1].

Precise data regarding the state of Serbia's building stock in terms of energy consumption and information about energy-efficient renovations of existing buildings are not available. However, it can be assumed without much doubt that the situation is alarming, similar to the rest of Europe, and that the need for more extensive energy reconstruction is a priority. The question that certainly arises from the very beginning is what our building stock is like, what its structure is, and what possibilities exist for achieving energy savings. A prerequisite for any intervention is understanding the structure of the residential building stock and defining the existing quality of residential comfort within it.

This study presents an analysis of the current state of the residential building stock in Belgrade, aiming to showcase the existing conditions and possibilities for its renovation. Specific models representing past construction practices have been singled out for energy consumption analysis. The focus of the study is primarily on multi-family residential buildings as they are subject to legal regulations and have undergone intensive technical improvements.

## 2. METHODOLOGY

The research on the quality of the residential building stock in Belgrade from the perspective of energy consumption was conducted through an analysis of adopted typical models that represent former architectural concepts and were materialized in a manner that was prevalent in the past. The residential building stock was analyzed through characteristic time periods that represent coherent entities in terms of applied thermal envelope assemblies and construction techniques used at the time. In this way, characteristic construction types were defined, typical thermal envelope assemblies were identified, and based on this, models were created representing specific architectural periods.

The periodization of the residential building stock and the typological approach to analyzing energy consumption and potential energy savings were applied in the

project "National Typology of Residential Buildings in Serbia." This project was carried out using the Tabula methodology within a three-year research period (2010–2012) by a group of professors and collaborators from the Faculty of Architecture in Belgrade [3]. In the Tabula project, the analysis of the building stock was performed on specific buildings that, based on their characteristics, corresponded to a typical sample obtained through statistical data analysis. In this study, the approach is different, as the analysis of the building stock is conducted on a model apartment that is materialized differently in accordance with the characteristic construction methods for the considered period [4]. Considering that the current Regulation on the Conditions, Content, and Method of Issuing Energy Performance Certificates for Buildings [5] also includes energy certification of apartments, this approach provides a closer determination of the quality of individual residential units in terms of thermal comfort, which is of great importance for apartment users.

The model apartment is part of a typical floor in a standalone residential building, and in terms of its functional and dimensional characteristics, it is identical across all models (Fig. 1). The building's layout is typical and can be recognized across all construction periods; it is organized with a centrally positioned staircase and four two-bedroom apartments of the same dimensions, with an area of approximately 60 m<sup>2</sup>. Variable window dimensions and floor heights reflect the characteristics of the construction period. In terms of vertical arrangement, the residential unit is integrated into the central part of the building so that there is residential space both above and below, which is the most common arrangement in multi-family residential buildings. The apartment is one-sided and south-facing, but other orientations and different apartment positions were considered, along with the consequences this has on energy consumption.

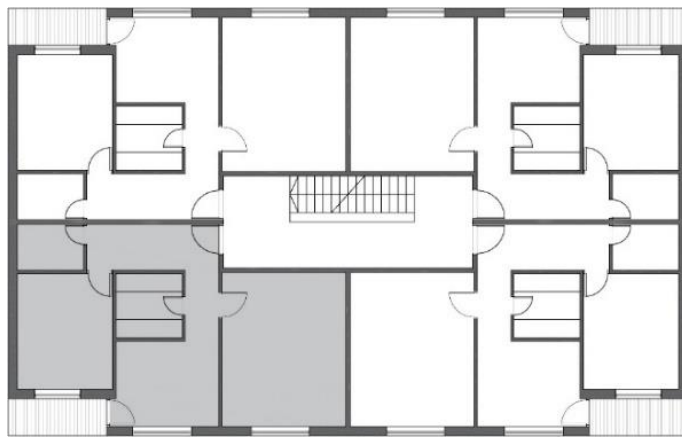


Figure 1. Analyzed residential unit within the typical floor (Image by author)


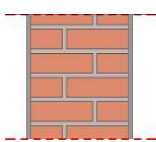
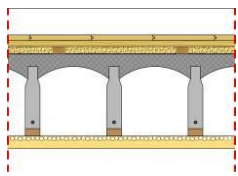

### 3. REPRESENTATIVES OF THE BELGRADE RESIDENTIAL BUILDING STOCK

The models used for energy efficiency analysis are materialized to represent buildings constructed in the past, which now constitute the city's residential building stock.

The first model represents traditional brick construction, which was prevalent until the end of the 1950s, when the intensive use of prefabricated systems began (Table 1). It is materialized according to the principles of interwar construction: the walls are made of new-format bricks introduced in 1931, and the intermediate floor structure is a ribbed semi-precast type called Herbst, which was commonly used at the time. Wide window recesses were used throughout this period until the advent of prefabricated systems and thinner walls. Such a window, with a wide wooden frame and a three-part opening (dimensions 200/160 cm), is adopted in the first model.

The heat transfer coefficient does not meet current thermal insulation requirements for the wall assembly and windows, while it falls within permissible limits for the intermediate floor structure [6].

Table 1. Model 1: building envelope structure and Heat transfer coefficients


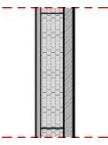
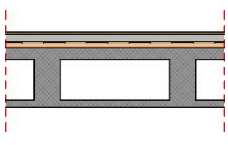

Model 1			
External view	Building envelope structure		
	Eternal wall	Floor construct.	Window
			
	brick wall 38 cm plastered on both sides	Herbst floor construction with parquet floor and reed ceiling	wooden, double frame, (wide box) external roller wooden blind
<b>Heat transfer coefficient ( W/m<sup>2</sup>K)</b>	<b>U=1.25</b> U > U <sub>max</sub> =0,4	<b>U= 0.78</b> U < U <sub>max</sub> =0,9	<b>U= 2.6</b> U > U <sub>max</sub> =1.5

The second model represents prefabricated construction, which began in the 1960s with intensive use of the domestic skeletal prestressed IMS system (Table 2). Buildings were designed in the spirit of modernism, with simplified forms, a cubic appearance, and facades often conceived as horizontal bands alternating between window openings running the entire length of the room and prefabricated parapet panels designed as multi-layered elements. Reduced parapet wall thicknesses, as well as construction savings, led to the more widespread use of windows with connected frames, displacing the use of double windows with wide and narrow recesses. Such a configuration with fabric blinds is adopted in this model. Changes also occurred in dimensional standards, with legal regulations allowing for significantly lower floor heights, which affected residential construction. A minimum

clear height of 240 cm was introduced, although it was less commonly applied in practice. In the second model, a height of 250 cm is used.

The heat transfer coefficient does not meet current thermal insulation requirements for the wall assembly and windows, while it falls within permissible limits for the intermediate floor structure. This can be explained by the specific characteristics of the floor slab, which include a layer of trapped air within its structure.


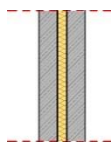


Table 2. Model 2: building envelope structure and Heat transfer coefficients

Model 2			
External view	Building envelope structure		
	Eternal wall	Floor construct.	Window
			
	parapet element, combination of regular and foam concrete	IMS construction, prefabricated concrete with parquet floor	wooden, double frame, connected sash; single glazed canvas roller blind
<b>Heat transfer coefficient ( W/m<sup>2</sup>K)</b>	<b>U=1.46</b> U > U <sub>max</sub> =0,4	<b>U= 0.81</b> U < U <sub>max</sub> =0,9	<b>U= 2.8</b> U > U <sub>max</sub> =1.5

The third model represents the period of advanced prefabrication, which began in the late 1970s and continued throughout the 1980s, reaching its peak with the implementation of the Rad-Balansi system. This system was used in the construction of many residential complexes in Belgrade, and its characteristics, as a representative of advanced prefabrication, are incorporated into this model (Table 3). The Balansi system consists of reinforced concrete panels, which are installed in a transverse direction for larger residential blocks, so that the longer side of the facade panel is designed as a load-bearing element, often of one floor's height, with formed openings. Facade panels are structured as multi-layered reinforced concrete elements with thermal insulation in the interlayer space. The intermediate floor structure consists of prefabricated, assembled 16-cm-thick panels with a floating floor and a finishing layer of parquet. In buildings realized during this period, a model of facade panels with two smaller openings instead of one larger opening was often used, which is adopted in this model. Two windows with dimensions of 1/1.4m are applied. By the late 1970s, due to advancements in thermal glass production technology, single wooden windows with built-in seals and glazed coatings had emerged, replacing double windows with connected frames in the following decade. Wooden shutters are often used in combination with such windows as external shading devices.

The results of the thermal calculation for the third model indicate that none of the applied structural elements have a heat transfer coefficient within the limits specified by the existing EEZ regulations. By comparing these values with the standards applicable at the time of the construction of such buildings, their compliance with the thermal regulations of that era can be assessed.

Table 3. Model 3: building envelope structure and Heat transfer coefficients


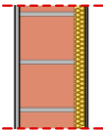
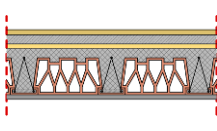

Model 3			
External view	Building envelope structure		
	Eternal wall	Floor construct.	Window
			
	prefabricated reinforced concrete panel 20cm with thermal insulation	reinforced concrete slab 16cm, with parquet floor	wooden, double glazed unit, wooden shutters
<b>Heat transfer coefficient ( W/m<sup>2</sup>K)</b>	<b>U=0.82</b> U > U <sub>max</sub> =0.4	<b>U= 1.84</b> U < U <sub>max</sub> =0.9	<b>U= 3</b> U > U <sub>max</sub> =1.5

The abandonment of prefabricated reinforced concrete systems and the return to traditional construction methods characterize the late twentieth century. The relinquishment of construction activity to market conditions, along with the decline of large construction companies that possessed experience and equipment for extensive construction projects, contributed to newly formed investors and contractors resorting to simpler and more cost-effective building solutions, utilizing maximum savings. This approach had implications for housing quality. An improved traditional construction system is applied, and clay elements are once again widely used in wall and ceiling construction (Table 4). The structural parts of walls are covered with thermal insulation materials, typically 5-8 cm thick, and the final layer is usually composed of a thin-layered facade render, a characteristic finishing for cost-efficient residential construction aimed at saving on all aspects of the building. Architects' aspiration for more flexible façade design, compared to the rigid regulations imposed by the prevailing norms regarding parapet height, introduced a new dimensional relationship where the absence of a wall parapet is compensated with an external railing of regulated height. On the facades of newly constructed residential buildings, elongated window openings with low parapets, or without them, are noticeable, along with so-called French balconies featuring single or double doors and an exterior railing of appropriate height. In the 1990s, the production of plastic windows began, which gradually displaced wooden windows, primarily due to their easy maintenance, good thermal properties, and low cost. In line with the aforementioned observations on façade element formation and the materials used for its construction, an opening is designed in the fourth model for assessing

residential comfort quality. It features plastic doors with dimensions of 140–220 cm, made from plastic profiles, and an external shutter of the same material.

The results of the thermal calculation for the fourth model show that the analyzed individual components do not meet the currently prescribed heat transfer coefficient values [6].

Table 4. Model 4: building envelope structure and Heat transfer coefficients

Model 4			
External view	Building envelope structure		
	Eternal wall	Floor construct.	Window
			
	cavity clay block wall with plastered thermal insulation	LMT reinforced concrete construction with hollow clay block 20 cm, parquet floor	single three-chamber plastic window, double glazed, external roller blind
Heat transfer coefficient ( W/m <sup>2</sup> K)	<b>U=0.53</b> U > U <sub>max</sub> =0,4	<b>U= 0.93</b> U < U <sub>max</sub> =0,9	<b>U= 3</b> U > U <sub>max</sub> =1.5

#### 4. THE RESULTS OF THE THERMAL CALCULATION

The energy efficiency calculation for the adopted models was performed using the Knauf Term 2 software, developed by Dr. Aleksandar Rajčić [7].

The energy balance of the first model is presented in Table 5, indicating that the highest transmission losses occur through the external wall. This arises from the dominant surface area of this building envelope element and the heat transfer coefficient values that triple the allowed limits. By summing up all relevant factors, the heating energy demand per unit area is calculated as  $Q_{h,an} = 121.97 \text{ kWh/m}^2\text{a}$ , corresponding to energy class E, which exceeds the prescribed values according to the existing regulations for existing buildings [5].

The distinctiveness of the second model, compared to the other representatives, lies in the envelope structure, where the surface area of the façade wall is equal to the surface area of the windows on the south facade, a result of the design characteristics of the early prefabricated buildings in Belgrade. Horizontal window bands alternating with concrete parapet elements are characteristic of this construction period, leading to certain specificities in the thermal calculation results.

The high thermal conductivity coefficient of the adopted window with connected frames (which has poorer thermal characteristics compared to windows with separate frames), along with its greater representation in the envelope structure, contributes to heat losses through the window that are nearly equal to losses through the external walls (Table 5). The higher proportion of transparent components in the

overall envelope area, combined with the façade parapet element, which also has unfavorable thermal characteristics, results in the highest transmission losses for this model.

Table 5. Models 1 and Model 2: Heat losses, energy class and energy consumption

Model 1		
Heat losses (W/K)	Heat losses (%)	Energy class
Heat losses of elements of the thermal envelope: area, heat losses (W/K and %) 1. external wall: 51.4 m <sup>2</sup> , 64.4 W/K, 62.6%      3. windows: 10.6 m <sup>2</sup> , 27.5 W/K, 26.7 % 2. wall to unheated area: 14 m <sup>2</sup> , 7.8 W/K, 7.6%      4. door: 2.1 m <sup>2</sup> , 3.2 W/K, 3.1 %		
Transmission losses: Qt = 6692.50 kWh	Solar gains: Qsol = 1026.6 kWh	Heating energy Demand Q <sub>h,nd</sub> = 7037.58 kWh
Ventilation losses: Qv = 2419.76 kWh	Other gains: Qp+Qel= 1048.04 kWh	Heating energy demand per m <sup>2</sup> Q <sub>h,an</sub> =121.97 kWh/m <sup>2</sup> a
Model 2		
Heat losses (W/K)	Heat losses (%)	Energy class
Heat losses of elements of the thermal envelope: 1. external wall: 32.7 m <sup>2</sup> , 47.7 W/K, 41.7 %      3. windows: 16.3 m <sup>2</sup> , 45.7W/K, 39.9% 2. wall to unheat. area: 11.4 m <sup>2</sup> ,17.8 W/K, 15.6%      4. door: 2,1 m <sup>2</sup> ,3.2 W/K, 2.8 %		
Transmission losses: Qt = 7294.37 kWh	Solar gains: Qsol = 3295.3 kWh	Heating energy Demand Q <sub>h,nd</sub> = 6407.07 kWh
Ventilation losses: Qv = 3456.60 kWh	Other gains: Qp+Qel= 1048.04 kWh	Heating energy demand per m <sup>2</sup> Q <sub>h,an</sub> =110.98 kWh/m <sup>2</sup> a



Ventilation losses, indicative of poor sealing of the windows, which is characteristic of windows with connected frames, also contribute to the model's unfavorable situation. When combined with transmission losses, this leads to the highest overall energy requirement for compensation. A large share of transparent components, in combination with inadequate shading systems (adopted fabric blinds as a typical solution in buildings from that period), results in extreme solar gains, contributing to a reduction in total heat losses and a more favorable overall energy balance (Table 5).

By summing up all the aforementioned relevant factors, the heating energy demand per unit area is calculated as  $Q_{h,an} = 110.98 \text{ kWh/m}^2\text{a}$ , corresponding to energy class E. The pronounced unfavorable aspects revealed in the calculation of heat losses were mitigated by high solar gain values, leading to a slightly more favorable overall energy balance for the second model compared to the first.

The results of the thermal calculation for the third model show the extreme value of the wall adjacent to the unheated staircase area, and its contribution to the total transmission losses is significantly higher compared to the previous cases. When compared with the values that were relevant during the construction of such buildings, compliance with the thermal regulations of that time is assessed. The envelope structure graph in the table indicates a predominant surface area of the façade wall compared to the window element (ratio of 80% to 20%), but the redistribution of transmission losses through the envelope shifts and balances the window's contribution in the total calculated values (Table 6). This situation can be explained by significant differences in heat transfer coefficient values between the external insulated wall and the single-pane wooden window with thermal insulating glass (wall:  $U=0.8 \text{ W/m}^2\text{K}$ , window:  $U=3.0 \text{ W/m}^2\text{K}$ ).

The energy balance of the third model is presented in Table 6, showing that the values of losses and gains are the lowest compared to the previously analyzed cases. This is a result of the better thermal characteristics of the external wall and significantly reduced ventilation losses due to the estimated better sealing of the applied windows. On the other hand, thermal gains are influenced to some extent by the shading equipment factor ( $F_z=0.3$ ), which leads to the lowest values (compared to previously analyzed models) of the required energy for heating per unit area:  $Q_{h,an} = 88.58 \text{ kWh/m}^2\text{a}$ , corresponding to energy class D.

The results of the thermal calculation for the fourth model indicate that the analyzed individual components do not meet the current prescribed values for heat transfer coefficients, which is particularly pronounced in the case of windows, which now dominate in the share of heat losses (Table 6). This is a consequence of the significant differences in heat transfer coefficients between the two represented components of the building envelope (wall:  $U=0.53 \text{ W/m}^2\text{K}$ , window:  $U=3.0 \text{ W/m}^2\text{K}$ ).

The energy balance of the fourth model (Table 6) shows higher values of transmission losses compared to ventilation losses, with values similar to those in the previously analyzed case. Ventilation losses are identical due to the same volume of space and the same window sealing characteristics. Transmission losses are slightly lower than in the previous model, but solar gains are also lower, resulting in the final energy balance required for heating per unit area: corresponding to energy class D.

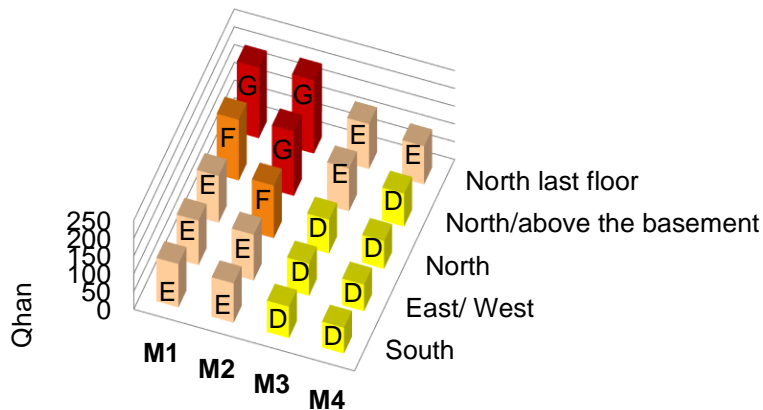
Table 6. Model 3 and Model 4: Heat losses, energy class and energy consumption

Model 3		
Heat losses (W/K)	Heat losses (%)	Energy class
Heat losses of elements of the thermal envelope: 1. external wall: 40.6 m <sup>2</sup> , 33.1 W/K, 40.2 %      3. windows: 9.3 m <sup>2</sup> , 28 W/K, 4 % 2. wall to unheat. area: 12 m <sup>2</sup> , 18.2 W/K, 22 %      4. door: 2.1 m <sup>2</sup> , 3.2 W/K, 3.8 %		
Transmission losses: Qt = 5365.30 kWh	Solar gains: Qsol = 700.9 kWh	Heating energy Demand Q <sub>h,nd</sub> = 5113.72 kWh
Ventilation losses: Qv = 1497.88 kWh	Other gains: Qp+Qel= 1048.04 kWh	Heating energy demand per m <sup>2</sup> Q <sub>h,an</sub> = 88.58 kWh/m <sup>2</sup> a
Model 4		
Heat losses (W/K)	Heat losses (%)	Energy class
Heat losses of elements of the thermal envelope: 1. external wall: 40.3 m <sup>2</sup> , 21.4 W/K, 32.8 %      3. windows: 11 m <sup>2</sup> 33 W/K, 50.5 % 2. wall to unheat. area: 11.9 m <sup>2</sup> , 7.8 W/K, 11.9%      4. door: 3.2 W/K, 4.8 %		
Transmission losses: Qt = 4348.62 kWh	Solar gains: Qsol = 594.5 kWh	Heating energy Demand Q <sub>h,nd</sub> = 4203.43 kWh
Ventilation losses: Qv = 1497.88 kWh	Other gains: Qp+Qel= 1048.04 kWh	Heating energy demand per m <sup>2</sup> Q <sub>h,an</sub> = 72.81 kWh/m <sup>2</sup> a

## 5. DISCUSION

Based on the presented results, it can be concluded that the first two models, representing older construction periods (up to the mid-1970s), have thermal characteristics that are one energy class worse than the apartments built later. This is expected considering the development of technical regulations in this field, which

tightened thermal standards and contributed to qualitative changes. It's important to emphasize that the study considered the more favorable positions of apartments that are south-facing and located between residential floors in terms of the building's height. If the apartment's orientation is different or its position within the building is less favorable, the amount of energy required for heating and the energy class can change. Figure 2 shows different positions and orientations of the model apartments, which were materialized according to typical configurations characteristic of specific construction periods. The most significant variations occur in the first two models, where depending on the orientation and position within the building, the energy class can change by up to two energy levels (from E to G).



	M1	M2	M3	M4
South	121.97	110.98	88.58	72.81
East/ West	124.82	128.87	90.68	74.82
North	131.68	148.05	95.32	78.72
North/above the basement	171	181.37	120.52	92.82
North last floor	198.58	205.87	126.32	107.42

Figure 2. Energy consumption depending on the different orientation of the apartments and position in building (Image by author)

## 6. CONCLUSION

The 2022 census provided data indicating that the housing stock in Belgrade consists of 868,752 units (Fig. 3). If these data are juxtaposed with the years of enactment of regulations related to thermal insulation, a clear picture emerges of the types of structures constituting the city's housing stock.

Specifically, the issue of thermal insulation of buildings was first introduced in the domestic technical regulations within the framework of the 1967 Regulation on Minimum Technical Conditions for the Construction of Apartments. However, the most significant change in this field occurred in 2011, when thermal protection requirements were considerably tightened, thermal transmittance coefficients were drastically reduced, and mandatory building certification was introduced. By comparing the graph of the number of constructed housing units with the pivotal year of legal enforcement of thermal insulation norms, it becomes evident that by that

time, 30% of the existing buildings had already been constructed. From then until the adoption of the Energy Efficiency Regulation [6] in 2011, 50% of buildings were constructed according to standards significantly below contemporary thermal protection requirements, while 15% of buildings were constructed to modern standards. The European Union's strategy [1] envisages the possibility of certifying existing buildings to stimulate a wave of energy retrofitting. Given that the trend of energy retrofitting existing buildings is not extensively observed in our context, these data undeniably indicate that only a small number of buildings meet modern thermal protection criteria and necessitate reconstruction.

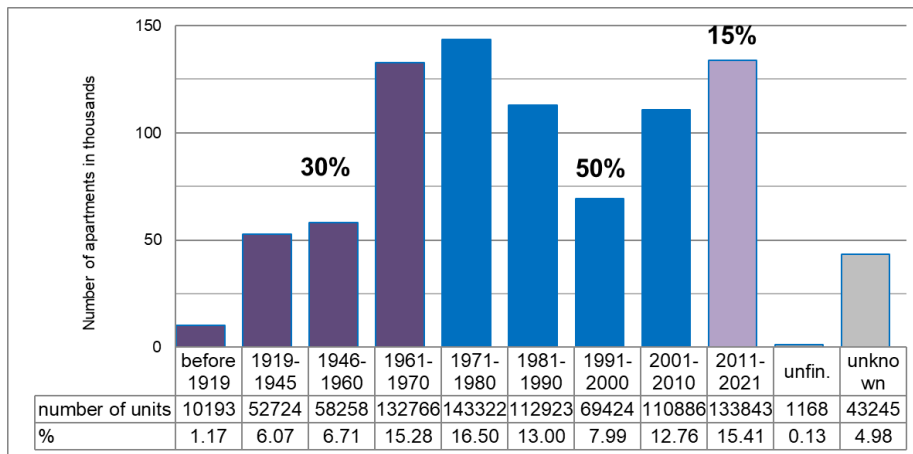


Figure 3. The number of apartments according to the periods of construction and according to the years of adoption of thermal regulations (Image by author)

## REFERENCES

- [1] European Commission: **A Renovation Wave for Europe** – greening our buildings, creating jobs, improving lives. Available online: <https://eur-lex.europa.eu/legal-content/EN/TXT/?uri=CELEX%3A52020DC0662> (accessed on 15 July 2023).
- [2] European Commission: **A European Green Deal**. Available online: [https://ec.europa.eu/info/strategy/priorities-2019-2024/european-green-deal\\_en](https://ec.europa.eu/info/strategy/priorities-2019-2024/european-green-deal_en) (accessed on 15 July 2023).
- [3] Jovanović Popović Milica, at all: **National typology of residential buildings in Serbia**. Faculty of Architecture, University of Belgrade and GIZ, Belgrade, 2013.
- [4] Đukanović Ljiljana: **Komfor u beogradskim stambenim zgradama**, Univerzitet u Beogradu Arhitektonski fakultet, Beograd, 2021.
- [5] Vlada Republike Srbije: **Pravilnik o uslovima, sadržini i načinu izdavanja ertifikata o energetske svojstvima zgrade**, *Službeni glasnik RS*, br. 69/2012, 2012.
- [6] Vlada Republike Srbije: **Pravilnik o energetske efikasnosti zgrada**, *Službeni glasnik RS*, br. 61/2011, 2011.
- [7] Aleksandar Rajčić: **KanufTerm2 PRO**. Available online: <https://www.knaufinsulation.rs/knaufterm-2-pro-srbija>

## EFFLUENT QUALITY FROM THE WASTEWATER TREATMENT PLANT LESKOVAC

Rastislav Trajković<sup>1</sup>, Marija Milićević<sup>2</sup>, Dragan Milićević<sup>3</sup>

### Abstrakt

*This paper describes the central wastewater treatment plant (WWTP) "Leskovac" in Bogojevac, where wastewater from Leskovac and several suburban and rural settlements is treated - municipal, atmospheric, industrial without and with pretreatment. Wastewater from the City of Leskovac, which is received at the plant, is a mixture of municipal, atmospheric and industrial water with pretreatment. The capacity of the plant in the first phase of construction is 86,000 equivalent inhabitants, and the recipient of the treated water is Južna Morava. The treatment process includes two process lines - water treatment and sludge treatment. The paper analyzes the results of daily laboratory measurements of wastewater at the entrance and exit of the waterline of WWTP Leskovac in the 21.09 - 19.10.2022. period. The analysis of the plant showed that for the adopted purification technology, the quality of the effluent is in accordance with the current legal regulations and within the framework of the permitted - limit values of polluting substance emissions, and that its construction has largely solved the problem of wastewater for the city of Leskovac and several suburban and rural settlements.*

**Key words:** *Wastewater Treatment Plant, wastewater influent and effluent, analysis of wastewater parameters*

---

<sup>1</sup> MSc, Non-Employee Associate, Faculty of Civil Engineering and Architecture, University of Nis, Serbia  
trajkovic.rastislav@gmail.com

<sup>2</sup> BSc, Non-Employee Associate, Faculty of Civil Engineering and Architecture, University of Nis, Serbia  
marijamilicevic119@gmail.com

<sup>3</sup> Dr, Associate Professor, Faculty of Civil Engineering and Architecture, University of Nis, Serbia  
dragan.milicevic@gaf.ni.ac.rs

## 1. INTRODUCTION

Wastewater represents water which has, after being used for certain purposes, changed its quality, so that it cannot be used anymore. With the use of water there are physical, chemical and biological changes in the quality of water. Wastewater contains different soluble and insoluble substances of organic and non-organic origins as well as microorganisms which can be hazardous for human health and the environment. This is why, before being released into a recipient or used again, the wastewater should undergo appropriate treatment [1].

Wastewater treatment technologies vary depending on different conditions which apply for each settlement and each recipient. These conditions include quality and quantity of raw water, environmental conditions, characteristics of the recipient, number of inhabitants connected to the sewage system, cost-effectiveness analysis of investment and exploitation expenses, availability of a qualified personnel, climate and geological conditions, location of the treatment plant, etc [5, 6].

The central wastewater treatment plant (CWWTP) Leskovac includes primary and secondary/biological wastewater treatment using biological aeration basins. The aim of this paper is to assess the quality of effluent and efficiency of wastewater treatment of the central wastewater treatment plant Leskovac based on the analysis of quality of incoming wastewater and outgoing treated water, conducted during the commissioning of the plant.

## 2. MATERIALS AND METHODS

Leskovac is an urban settlement and administrative center of the territorial unit of the same name and the Jablanica administrative district, situated in the Leskovac valley (Figure 1).

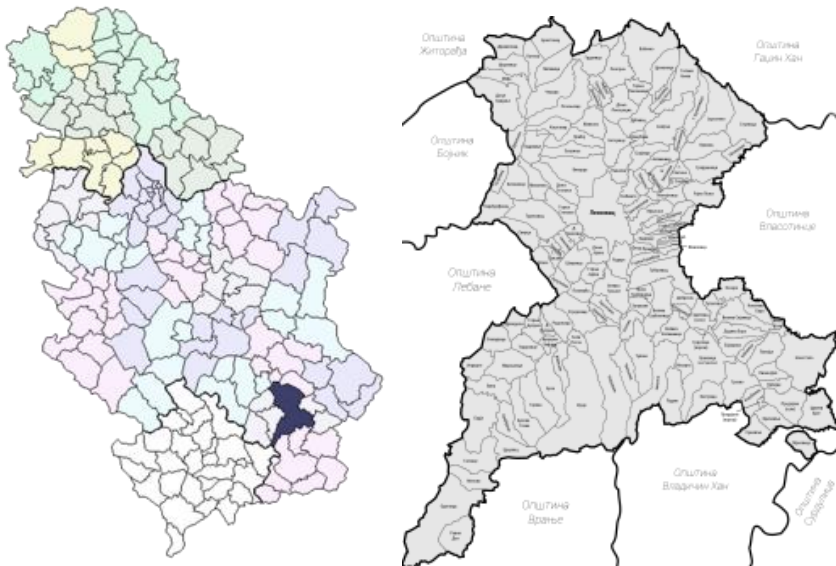


Figure 1. The City of Leskovac

The river Veternica flows through the city itself, and nearby flows the river Južna Morava which receives all of the larger tributaries. The municipality of Leskovac has

144 settlements, Leskovac, Vučje and Grdelica being urban settlements. According to the 2011 census on the territory of the municipality of Leskovac there were 144.206 inhabitants, while there were 60.288 inhabitants living in the city itself. According to the 2022 census there are 125.876 inhabitants currently living on the territory.

All wastewater of the city of Leskovac, including municipal, atmospheric and industrial, with or without pretreatment is transported gravitationally via the city's sewer collector to the Central wastewater treatment plant located in the village of Bogojevac. After the treatment process, the treated wastewater is released into the recipient Južna Morava. The project of collecting and treating municipal wastewater of the city of Leskovac entails the following basic elements [6]:

The main municipal sewer collector which collects all wastewater from the city of Leskovac city core and surrounding areas which gravitate towards the CWWTP in Bogojevac

Expansion of the combined sewer network for collecting wastewater in surrounding suburban and rural settlements connected to the city of Leskovac. This wastewater will be transported to the CWWTP in Bogojevac.

CWWTP Leskovac where wastewater treatment will be done including primary and secondary/biological treatment.

There are 22.600 users connected to the sewer network of the city of Leskovac, including around 16.000 households and 1300 legal entities. The project aims to adopt an efficient wastewater collection and treatment system in Leskovac, which will significantly contribute to the protection of the environment and improve the quality of life of the population [6].

Central wastewater treatment plant (CWWTP) Leskovac is located in the territory of the village Bogojevce, about 5.6 km northeast of the urban area of Leskovac. The total area of the lots covered by the Central wastewater treatment plant Leskovac complex in Bogojevac village is around 24 ha according to the Detailed urban plan. The area of the plant itself is around 7.5 ha [6].

Phase one of the CWWTP, which includes facilities of the water process line with partial sludge treatment for 86,000 IE was built in 2016 and started operation in 2022. Phase two, which includes facilities of the sludge process line with anaerobic digestion for 86.000 IE was built and started operation in 2022. Phase three intends to expand the capacity of the complete CWWTP to 129,000 IE has not yet been built [6].

Figure 2 shows the site plan of the CWWTP in Bogojevac. As part of Phase 1, the following structures and supporting infrastructure were built (the number behind the structure name represents the number on figure): coarse bar screens and raw water pump station (01), compensation basin for atmospheric water (02), fine bar screens (01), aerated sand traps/grit chambers for removal of sand and floating particles (03), inlet flow meter (03), primary settling tanks – two units (04), primary sludge pump station (05), biological aeration basins (06), compressor station (07), final settling tanks – two units (08), outlet, flow meter and quality monitoring (09), return sludge pump station (10), waste sludge pump station (10), primary sludge thickener and pump station (11), mechanical sludge thickener (13), sludge storage and mixing tank with pump station (12), supernatant tank and pump station (12 and 13), sludge conditioning and dewatering (13), administrative building and laboratory (19), workshop and storage for tools and equipment (16), electrical substation (18),

technical water and fire suppression system (17), service water disinfection (17), sludge storage facility (14), gatehouse (20), maintenance hole, lime dosing (13) [6].



Figure 2. Site plan CWWTP Leskovac (Phase 1) [6]

For the design of wastewater treatment facilities, peak hourly flow in dry weather conditions and process load were used according to the data in tables 1 and 2.

Table 1. Flow and inhabitant equivalent - Phase 1 [6]

CWWTP bulding phase	Phase 1
Peak hourly flow during rainy period-extreme, l/s	1500
Peak hourly flow during rainy period--usual, l/s	1000
Peak hourly flow in dry weather (DWF), l/s	490
Peak daily flow, l/s	310
Average daily flow, l/s	240
Inhabitant equivalent, IE	86000

Table 2. Wastewater quality, demanded quality of treated water and efficiency of treatment [6]

Parameter (Phase 1)	Wastewater quality, inlet	Treated water quality, outlet	Smallest percentage reduction (%)
Suspended solids, (mg/l)	295	35	70-90
Biological oxygen demand, (mgO <sub>2</sub> /l)	250	25	70-90
Chemical oxygen demand, (mgO <sub>2</sub> /l)	500	125	75



<i>Total nitrogen (mg/l)</i>	46	15 or 25	70-80
<i>Total phosphorus (mg/l)</i>	7.5	2	80

Facilities of the water process line with partial sludge treatment (facilities of Phase 1 of CWWTP) were commissioned in 2022. The contractor was the company Veolia Water Solutions & Technologies doo Belgrade, while technical supervision was done by the company Projektinženjering TIM doo Niš, under management of Prof. dr. Dragan Milićević.

The primary goal of commissioning of facilities on the water process line with partial sludge treatment (facilities of Phase 1 of CWWTP) is to complete: defect detection before beginning of operation of machines, electrical and control equipment which has not been serviced and elimination of defects which could occur during beginning of operation; training of staff which will work on maintenance of the CWWTP; a completely automated process with remote control through a SCADA system; to ensure a wastewater treatment process with proven effluent qualities in accordance with the project and/or legislation and to provide sludge for the sludge processing line in the facilities of the water process line as a prerequisite for the commissioning of the facilities of the sludge process line (facilities of Phase 2 of CWWTP).

Commissioning of facilities of Phase 1 of the CWWTP was completed in three phases [6]:

Preparatory activities before commissioning and formation of complete biology on the facilities of the water process line – the first 3 months;

Optimization of biological reactor operation and beginning of production of surplus sludge – month 3 to month 6;

Management of facilities of the water process line (Phase 1 of CWWTP) with coordination of operation of facilities on the sludge process line (Phase 2 of CWWTP) – month 7 to month 9;

During the commissioning of the facilities of the water process line with partial sludge treatment (facilities of Phase 1 of the CWWTP), hydraulic load of the water process line facilities has been continually measured on flow measuring devices installed on the facility. Regular water quality testing of raw water on the plant inlet and treated water on the plant outlet was done multiple times a month by an authorized laboratory [7]. The analysis of the obtained results and the creation of diagrams was performed in the Microsoft Excel program.

### 3. RESULTS AND DISCUSSION

Results of the testing during the commissioning of the facilities of the water process line with partial sludge treatment has been provided in the following paragraphs.

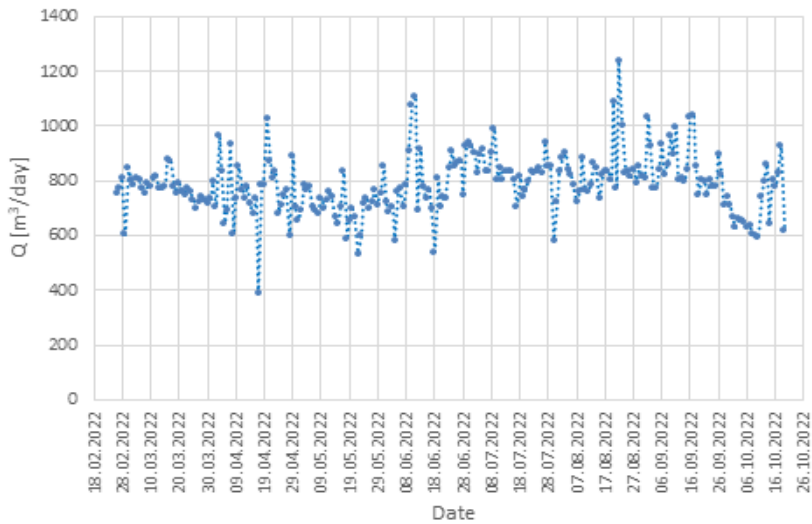


Figure 3. Average flow on the input to the CWWTP

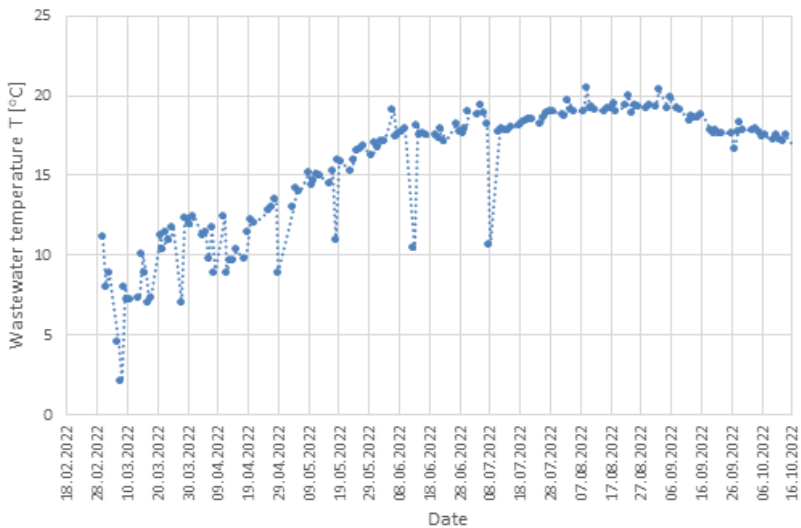


Figure 4. Wastewater temperature at the input of the CWWTP Leskovac

Biological processes are significantly impacted by weather/temperature conditions in which they take place as well as the normal hydraulic and biological load of the influent.

Water temperature on the CWWTP inlet during commissioning of facilities on the water process line was between 2.10°C and 20.40°C, with an average of 15.64°C.

During the commissioning of facilities on the water process line, the average daily flow on the entrance to the plant was measured between 387 m<sup>3</sup>/h (107.5 l/s) and 1240 m<sup>3</sup>/h (344.4 l/s), with an average of 786 m<sup>3</sup>/h (218.3 l/s), or between 44.8% and 143.5%, with an average of 91% of the projected average daily flow of 240 l/s.

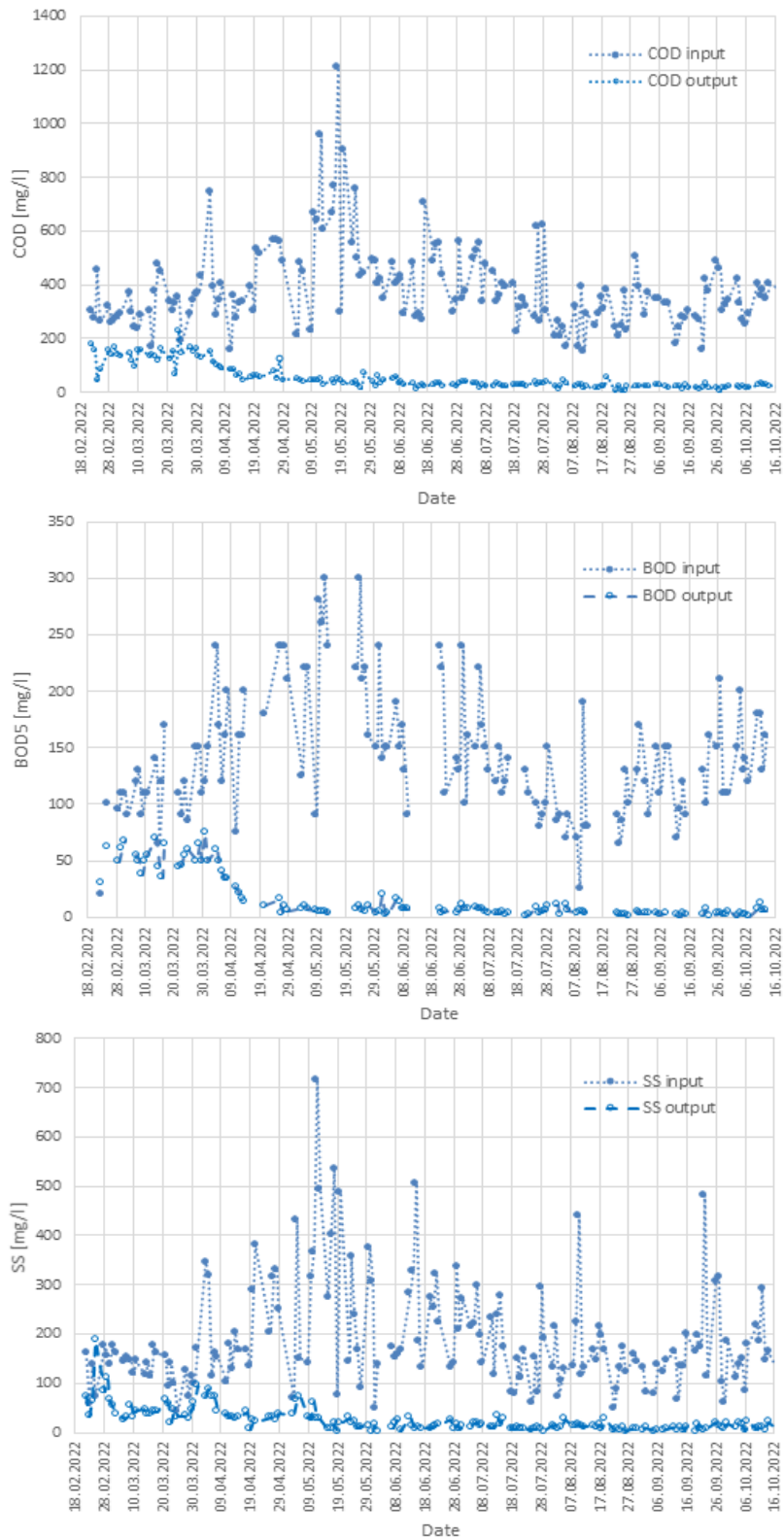


Figure 5. COD, BOD<sub>5</sub> and SS at the input and output of the CWWTP Leskovac

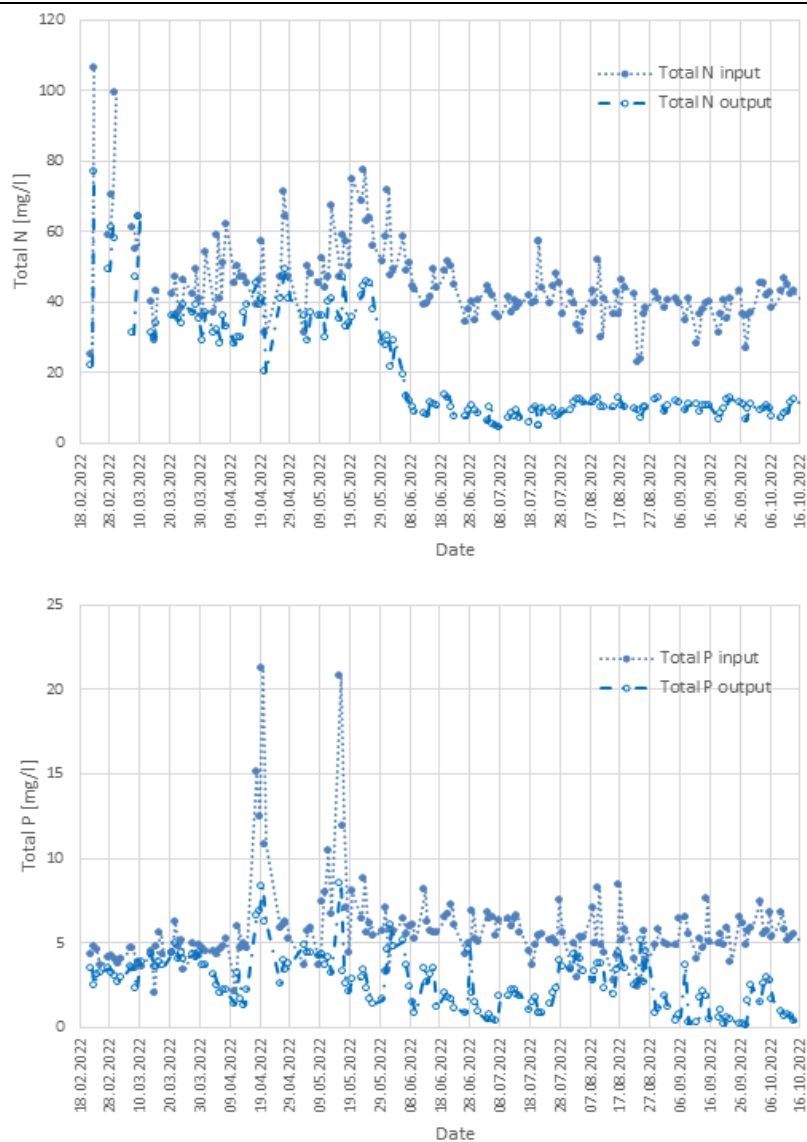


Figure 6. Total N and Total P at the input and output of the CWWTP Leskovac

Average values of physicochemical parameters of wastewater on the CWWTP Leskovac inlet during commissioning of facilities on the water process line were:

COD: 150.00 - 1209.00 mg/l average 399.47 mg/l (500)

BOD<sub>5</sub>: 20.00 - 300.00 mg/l average 142.56 mg/l (250)

SS: 42.00 - 716.00 mg/l average 188.83 mg/l (295)

Total N: 22.98 - 106.00 mg/l average 45.29 mg/l ( 46)

Total P: 2.04 -21.22 mg/l average 5.69 mg/l ( 7.5)

Assumed maximum concentration of the parameters of raw wastewater are given in the parentheses.

As it can be seen average load during commissioning of the facilities on the water process line was smaller than the presumed process load (by around 24% for COD and Total P, by around 35% for SS and around 43% for BOD), except for Total N.

Attained average values of physicochemical parameters of wastewater/treated water on the outlet of CWWTP Leskovac during commissioning of facilities on the water process line were [7]:

COD: 3.50 - 231.00 mg/l average 54.01 mg/l (125)  
BOD5: 1.00 - 75.00 mg/l average 16.21 mg/l ( 25)  
SS: 2.00 - 188.00 mg/l average 23.94 mg/l ( 35)  
Total N: 4.40 - 77.00 mg/l average 20.79 mg/l ( 15)  
Total P: 0.13 - 8.52 mg/l average 2.65 mg/l ( 2)

Permitted parameter values are shown in the parentheses, according to the Regulation on limit values of pollutant emissions.

Average efficiency of parameter removal was 83.69% for COD, 86.11% for BOD5, 83.48% for SS, 56.27% for Total N and 49.29% for Total P.

It should be noted that average values of physicochemical parameters on the CWWTP Leskovac outlet, as well as parameter removal efficiency were calculated for the entire period of commissioning of facilities on the water process line. In the start period of process establishment and stabilization until May 5<sup>th</sup> 2023 for COD, BOD5 and SS, or June 8<sup>th</sup> 2023 for Total N and Total P, values of physicochemical parameters of wastewater on the plant outlet fluctuated significantly and were very high, which can be seen on the graphs on Figures 5 and 6. This is why average values for Total N and Total P for the entire period of commissioning are not within the allowed – limit values of pollutant emissions and the efficiency of removal of these parameters is not satisfactory.

However, after May 16<sup>th</sup>, or June 8<sup>th</sup> 2023, there was a significant improvement of values of physicochemical parameters of wastewater on the outlet [7]:

COD: 3.50 - 76.00 mg/l average 27.36 mg/l (125)  
BOD5: 1.00 - 20.00 mg/l average 5.20 mg/l ( 25)  
SS: 2.00 - 33.00 mg/l average 11.57 mg/l ( 35)  
Total N: 4.40 - 13.50 mg/l average 9.57 mg/l ( 15)  
Total P: 0.13 - 5.15 mg/l average 1.89 mg/l ( 2)

Average efficiency of parameter removal after May 16<sup>th</sup> 2023, or June 8<sup>th</sup> 2023 had significantly improved and was 92.11% for COD, 95.96% for BOD5, 92.76% for SS, 76.00% for Total N and 62.80% for Total P.

Occasionally, there are problems on the plant regarding the removal of phosphorus, which is a consequence of low input biological load which is important for the removal of nitrogen and phosphorus nutrients (wastewater BOD5 around 55% of the presumed value of BOD5), as well as unusually high pH values for municipal wastewater, which occasionally appear in the wastewater at the plant inlet. Values this high can appear in combined sewage types where municipal wastewater is mixed with industrial wastewater. This is why additional measures regarding monitoring of industrial and other non-municipal polluters or users of the city's sewer network should be undertaken so the origins of the significant amount of wastewater pollutants can be determined and mandatory pre-treatment can be provided for industrial wastewater [7].

Based on the results all parameters of treated wastewater at the CWWTP Leskovac outlets are within the demanded limit values of pollutant emission, except occasionally the parameter Total P, but after the achievement of the planned organic load and building of the industrial wastewater pretreatment this problem is expected to be solved.

## 4. CONCLUSION

This paper gives a brief overview of the central wastewater treatment plant Leskovac in Bogojevac village used for treatment of municipal, atmospheric, industrial wastewater of Leskovac and multiple suburban and rural settlements with and without pretreatment. So far, Phase 1 which includes facilities of the water process line with partial sludge treatment for 86,000 IE and Phase 2 which includes facilities on the sludge line with anaerobic digestion for 86,000 IE have been built and have started operation. Phase 3, which includes facilities for the expansion of capacity for the complete CWWTP to 129,000 IE have not yet been built [6].

After commissioning of facilities of the water process line with partial sludge treatment (facilities of Phase 1 of the CWWTP) during 2022, analysis conducted at the plant have shown that the effluent quality is within the permitted – limit values of pollutant emissions and that by building the CWWTP, the problem of wastewater has mostly been solved for the city of Leskovac and multiple suburban and rural settlements.

## REFERENCES

- [1] Ljubisavljević Dejan, Djukić Aleksandar, Babić Bratislav: **Wastewater treatment (Пречишћавање отпадних вода)**, Faculty of Civil Engineering, University of Belgrade, Belgrade, 2004.
- [2] Jahić Munir: **Wastewater treatment (Пречишћавање загађених вода)**. Faculty of Agronomy, University of Novi Sad, Novi Sad, 1990.
- [3] Milićević Dragan, Trajković Slaviša, Gocić Milan: **Application of Macrobiological Methods in the Settlement Wastewater Treatment**. *Biological Wastewater Treatment and Resource Recovery*, Zaki Ahmad (Ed.), 17-36, DOI: 10.5772/65369, InTech, 2017.
- [4] **Council Directive 91/271/EEC** of 21 May 1991 concerning urban waste-water treatment, 1991.
- [5] Stojanović Marina, Vasović Dejan: **Water protection (Заштита вода)**. Faculty of Occupational Safety, University of Nis, Nis, 2019.
- [6] **Technical specification** for supervision services over commissioning of water line facilities (**Tehnička specifikacija** za usluge nadzora nad puštanjem u rad objekata linija vode PPOV Leskovac), Leskovac, 2022.
- [7] **Monthly reports** on the work progress (**Mesečni izveštaji** o napretku radova), Veolia Water Solutions & Technologies doo, Leskovac, 2022.
- [8] **Regulation on emission limit values** of pollutants in water and deadlines for achieving them (**Uredba o graničnim vrednostima emisije zagađujućih materija u vodi i rokovima za njihovo dostizanje**), "Official Gazette RS", No. 67/11, 48/12, 1/16, Belgrade, 2016.

## RE-VILLAGE ECOLOGICAL EXPERIMENTS IN ARCHITECTURE

**Andrej Josifovski<sup>1</sup>, Anđela Posavec<sup>2</sup>, Stefan Janković<sup>3</sup>, Jelena Milošević<sup>4</sup>**

### **Abstract**

*The theme of the work are villages as a source of a conceptually new life. The work is based on the research and professional work in the field of rural architecture, the architects from this area, Aleksandar Deroko, Branislav Kojić, Zoran Petrović and Branislav Milenković, who, among other things, examined the conditions for maintaining villages in conditions of rapid industrialization. Now, in the conditions of rapid ecological destruction, the setting gives something new rethinking the village as a resource that can be recycled or reused as the basis for the formation of a new typology: re-VILLAGE. The inspiration for this work came from several experimental attempts created in within the framework of domestic architecture, with the idea of presenting these endeavors as laboratory for potential ways of life. These experiments include cooperative living, organic food production, tight networks of energy exchange, different principles of ownership, and forms of exchange that resist market principles. One of the main goals is to affirm and popularize with this work everything that our country has, its natural resources and architecture that should be created in the spirit of nature. Through research work in the field of architecture, I came to a drawing of the village that was created more than ten years ago, when there was still not so much thought about returning to nature in the way that it is done more and more often today, which in many ways contributed to the concretization and improvement of the idea of returning to the village. Humans cannot be indefinitely separated from the nature in which they live, and precisely this need of man to return to the primordial is the main theme with which we come before the world, and architecture has an unfathomable power to give us answers and to unify it all. This project is actually the creation of a new typology for the future, which needs solutions already, because villages as we know them do not really exist anymore.*

**Key words: Recycling, Village, Ecology, Rural Architecture**

□

---

<sup>1</sup> PhD, assistant professor, master engineer of architecture, [andrej@arh.bg.ac.rs](mailto:andrej@arh.bg.ac.rs)

<sup>2</sup> Mrs, PhD candidate, master engineer of architecture, [andjela.dubljevic@gmail.com](mailto:andjela.dubljevic@gmail.com)

<sup>3</sup> PhD, assistant professor, sociologist, [stefan.jankovic@f.bg.ac.rs](mailto:stefan.jankovic@f.bg.ac.rs)

<sup>4</sup> PhD, assistant professor, master engineer of architecture, [jelena@arh.bg.ac.rs](mailto:jelena@arh.bg.ac.rs)

## 1. INTRODUCTION

Artistic director - curator of the current Architecture Biennale in Venice, academic, educator Lesley Lokko was the one who set the theme of the biennale: THE LABORATORY OF THE FUTURE.

In the explanation of the call for tenders, she refers to regions that are under development, to the world that is somewhere "out there", the so-called third world.

That was exactly the idea and reason for thinking about those spaces in our immediate environment. But first of all, what are the spaces of the third world and where is that "there" located?

In the literature, the term "third world" generally refers to the so-called underdeveloped countries. of the Global South, and actually refers mostly to poor, underdeveloped regions. City suburbs, however, in many ways can be considered a paradigm of such landscapes, so that "somewhere", of course, developed countries also have that.

The glow of the central city zones, already after a few minutes of driving outside their borders, more or less replaces the twilight of the periphery and this contrast is, one might say, more pronounced, proportional to the degree of development of the country. In our country, this diversity is certainly even more pronounced in a general comparison of urban and rural environments.

This was exactly the premise on which the idea of improving rural areas was theoretically developed, in accordance with the requirements imposed by the needs of modern life.

The functional setup of Leslina's Laboratory of the Future was conceived on the fertile, scorched rural soil of our homeland, which, through decades of systematic devastation, instead of developing into a rich treasury based on village development and agriculture, was directed towards the back of third world countries.

The recent pandemic of the COVID-19 virus, which paralyzed the cities and led to a true migration of the population to the "free territory" of the countryside, opened up many life issues and greatly triggered thoughts about changing the standards that previously favored the urban environment as a place to live. It also thematically founded and set the framework for the thinking in this work, in order to realistically consider the possibilities of safe "urbanization" of the village, and thus turning the rural and peripheral into a laboratory of the future, a new, central third world.

## 2. NICE VILLAGE

Research work in the field of architecture resulted in a drawing of the village that was created more than ten years ago, when there was still not so much thought about returning to nature in the way that it is done more and more often today, which in many ways contributed to the concretization and improvement of the idea of returning to the village.

Architect Đorđe Gec, with his artistic approach, solves the problem of everyday life on the slopes of Mount Kosmaj near Belgrade. On a plot of about 4.5 ha, he is developing the concept of a beautiful village for the life of 12 families, each of which borrows one field for use. Considering that all the fields are intended for different crops, a central object - a cooperative - was placed on the plot, where all the families would socialize and exchange goods. Also, each house has its own small cellar,



where it can store supplies necessary for the household. The project goes one step further, providing the entire possibility of coexistence, such as spaces for education and recreation, and regular transportation is provided twice a day from the village to the city and back, with a methane van.

It was a concept that was visionarily developed with the order and suggestions of the mastermind and investor Nikola Kojo, thanks to whom this project reached a new consideration to be realized one day.

### **3. RE-VILLAGE**

The immediate inspiration for the work came from several similar experimental attempts, created within the framework of domestic architecture, with the idea of presenting these endeavors as a laboratory of potential lifestyles. These experiments included cooperative living, organic food production, tight networks of energy exchange, different principles of ownership as well as forms of exchange that resist established market principles.

The topic of this work is villages as a source of a conceptually new life. In contrast to the research and professional work in the field of rural architecture, the doyen of architecture from this area, university professors Aleksandar Deroko, Branislav Kojić, Zoran Petrović and Branislav Milenković, who, among other things, examined the conditions for the maintenance of villages in conditions of rapid industrialization, now the issue of sustainability opens in conditions of rapid ecological destruction, where the setting gives a new consideration of the village as a resource, which can be recycled or reused and be the basis for the formation of a new typology: RE-VILLAGE.

One of the main goals is to affirm and popularize with this work everything that our country has, its natural resources, as well as the architecture that should create and develop in the spirit of nature.

The unpredictable circumstances of the turbulent modern age have led people to question existing beliefs and established feelings of individual and collective security. Until recently, the firm position that globalization is unstoppable and that living in the city is the only solution offered by the currents of civilization to social development, and thus to survival, was shaken by the pandemic and war in the previous years, causing real fear for survival. The question of survival in the world in the increasingly difficult conditions caused by climate change has acquired a new terrifying dimension, where the rapid disappearance of natural resources gives an apocalyptic sign to the future of humanity.

The answer to life in the future, which is now, more than ever, characterized as uncertain, cannot therefore be sought in the familiar concepts of housing and alienation from nature, which have proven to be certain. Acceptance of the view that cities are centers of consumption and landscapes centers of extraction has created an ecologically disruptive, one-way flow of energy and resources in biosphere metabolism. Therefore, a clear demarcation between industrial and rural areas is no longer possible, which on the other hand increasingly limits man and emphasizes the strong need for liberation and independence, which would be achieved by returning to and essentially connecting with nature.

A prerequisite for realizing this need in accordance with the modern way of life would be to establish a new connection between cities and rural areas in order to

achieve a connection with nature and alleviate the global shortage of resources. However, such a trend of re-migration from urban to rural areas requires a far more complex consideration of new ways of life in the countryside through architectural practice, where this "new, third world", dropped due to the essential urban colonization of space, would experience re-generation, re-population and re-vitalization. In a word, it is necessary to rethink the VILLAGE.

Therefore, re-VILLAGE emphasizes consideration of the following principles as a prerequisite for establishment:

1. Re-population: directing urban people to rural areas through the argumentative presentation of a new vision, which fully illuminates the modern meaning of a healthy life, based on a sustainable, and therefore ecologically acceptable way of exploiting natural resources.

2. Re-generation: the creation of educational programs for new generations, which would enable constant adaptation to the challenges of climate change through relatively flexible architectural solutions, and thus the realization of a continuous and healthy metabolic exchange with the environment.

3. Re-vitalization: laying the foundations of future ecological and human vitality, primarily through the construction of new forms of coexistence, by affirming one's own food production, cooperative forms of exchange and management, as well as a continuous, cyclical form of creating an adequate ecological base.

#### **4. ECOLOGICA EXPERIMENT IN ARCHITECTURE – A CONCEPT**

We are witnessing great industrial inventions, but also rapid ecological destruction. Therefore, the disproportion between those who, with their inventions and work, contribute to the improvement of healthy living conditions and those who care and take care of the preservation of the environment is obvious.

Under the slogan of the fight for a healthy life, everything is done in order to make a profit, so mostly unhealthy lifestyle foods of genetically modified origin, hormonally stimulated cultivation with additives and emulsifiers in their processing and packed in packaging made of non-degradable synthetic materials that pollute are produced and sold. and destroy the natural environment.

Ecological experiments should first of all have an educational role in order to improve and maintain a healthy life, which in fact is just something that is talked about, so that emphasizing the natural and healthy has turned into a profane phrase. Sustainable development as the basis of survival must be based on sound foundations and systematically and continuously achieved, in order to be adequately accepted, so that catastrophic events, such as pandemics of infectious diseases, will not be the ones that will bring people into harmony with the laws of nature.

Future of agriculture, a project of a group of people working on research into the production of organic seeds, which will also serve educational purposes, in order to produce quality food in the future, which was also the inspiration for this ecological experiment, which would be carried out in cooperation with architecture students, analogous to what is the product of their work - an arranged space for living. The test site would be in a preserved nature area, where young architects would provide design answers to all the challenges that can be expected from the population, re-generation, and re-vitalization of rural, remote areas with their projects. It would also be the testing ground of tomorrow where answers to a complex and very current

question, which Hashim Sarkis set as the theme of the last Biennale of Architecture - How will we live together? / How will we live together?.

## 5. TOWARDS RE-ARCHITECTURE – AN IDEA

The title of Le Corbusier's famous book *Towards True Architecture* is still very intriguing today, because the question of the true direction of today's architecture is certainly still open, so, given the views of this timeless architect, it could rather be said that instead of harmonizing construction in the spirit with the environment, opens a chasm that devours healthy nature day by day.

On his historic journey to the east, *Le voyage d'orient*, Charles Edouard Jeanneret-Gris Le Corbusier also visited Knjaževac. There are not many clues about this in his book of the same name, but his drawing of a Serbian village is known, where, in addition to the architecture, you can clearly see a Serbian peasant cultivating his field close to the house where he lives, which is certainly the convenience that working from home offers in the city today. .

In his master's thesis, *Natural and cultural assets in the function of the development of the rural area of the municipality of Knjaževac: a contribution to the research of development potentials in the rural area*, Goran Babić, M.Sc., talks, among other things, about the devastation of extremely fertile land by illegal dumping of tailings from the nearby mining basin. Given that soil testing for the purpose of opening mining pits on the fertile soil of Serbia has recently intensified, taking into account the toxicity of the mining process for some ores, such as lithium, it is an even greater threat to the healthy natural environment than it was then. The tools that are available to us are knowledge and innovation, and the reuse of the design method as in old architecture, conceptually leads us to RE-architecture.



*Figure 1. Knjaževac, Serbian village, Le Corbusier's drawing*

## 5. CONCLUSIONS

Based on the stated postulates of Re-migration, Re-generation and Re-vitalization, it can be concluded that the sustainability of the village in today's conditions of extreme depopulation and ecological devastation is possible, under the condition of intensification of agriculture and achieving extreme food industrialization

of the village, at the expense of stopping industrialization of another kind and stopping the harmful exploitation of mineral deposits. Typical construction would certainly contribute to the revitalization of the village, where residential units like Corbusier's would be in open communication with nature, which, along with modern technology, would provide full comfort to the residents. The arrangement of waste disposal and waste water drainage, as well as the construction of biosustainable energy generators, would greatly contribute to the preservation of a healthy environment. The construction of schools, kindergartens and clinics, centers of culture and administrative buildings with post offices, which would be the task of Re-architecture, should fully satisfy the needs of the future residents of Re-village.

## ACKNOWLEDGMENTS

I owe a great deal of gratitude to Nikola Kojo, actor and director, for his insight into the project, Goran Babić, M.Sc., graduate in architectural engineering, manager of the library of old and rare books of the Faculty of Architecture, University of Belgrade, for his selfless discovery of very important archival materials, and Tamara Živković, graduate librarian-informatics, for help with finding contemporary literature.

## REFERENCES

- [1] Kojić Branislav: **Seoska arhitektura i rurizam**. *Srpska akademija nauka i umetnosti*, Beograd, 1968.
- [2] Kojić Branislav: **Stara gradska i seoska arhitektura u Srbiji**. *Prosveta izdavačko preduzeće Srbije*, Beograd, 1949.
- [3] Deroko Aleksandar: **Narodno neimarstvo I - Stara seoska kuća**. *Srpska akademija nauka i umetnosti*, Beograd, 1968.
- [4] Milenković Branislav, Petrović Zoran: **Stanovanje na selu**.
- [5] Gorz Andre, Michel Bosquet: **Ecologie et politique**. *Editions du Seuil*, Paris, 1978.
- [6] Findrik Ranko: **Narodno neimarstvo**. *Muzej „Staro selo“ Sirogojno*, Sirogojno, 1994.
- [7] Charles Edouard Jeanneret-Gris Le Corbusier: **Le voyage d'orient**. Print Book, French, 1966.

# ARCHITECTURE AND TEXTILES - A MILLENNIAL STORY

Beatrice-Gabriela JÖGER<sup>1</sup>

## Abstract

*For millenia, the only source for textiles were the natural fibres and, as such, a low number of ancient textile artifacts survived up to our days. Being disregarded for a very long time and considered a by-product or having an insignificant function, it was never a problem of an overproduction of textiles, nor the resulting in waste that cannot be destroyed in a reasonable period of time.*

*The architecture is specific to humanity and some theories attribute its beginnings to the connection with the textiles, or, at least with the braiding (Semper, 1989). Construction materials were natural for millennia, too, so, many of them ephemeral as the textiles, reaching us only what was built in sustainable materials.*

*Until approximately two decades ago, the link between textiles and architecture was kept in low key, textiles being a study topic for the art field rather than for the architectural one. Besides the architects and artists that actively linked the two fields, the theoretical side was approached by very few. One can mention Gottfried Semper in the 19 c., and Marc Garcia, who coined the term Architextiles in 2006. Although not theorized, the relation between architecture and textiles is present in the popular architecture, the expression, "dressing the house" being used in the Romanian popular culture, referring to the textiles for the interior.*

*This long relation continues today, the latest technological innovations offering their support to the creators from both fields.*

*The paper is presenting the relation between the textiles and architecture through a short historical review, emphasising the architectural role of the textiles. Significant examples will be presented in order to underline the important moments of that relation. The discussion will be centered on the theoretical approach of the topic, while the conclusions will show its future made possible by the advanced technology.*

**Key words:** *architecture, textiles, architextiles, (nano)technology, innovation.*

---

<sup>1</sup> Prof. Beatrice-Gabriela JÖGER, Arch PhD Habil., "Ion Mincu" University of Architecture and Urban Planning, [beatrice.joger@uauim.ro](mailto:beatrice.joger@uauim.ro)

## 1. INTRODUCTION

For millenia, the only source for textiles were the natural fibres and, as such, a low number of ancient textile artifacts survived up to our days. The oldest fibres used in textiles, in fact micro fibres, were discovered, thanks to nowadays technology, in an archeological site in the Dzudzuana cave from Georgia [1]. The natural fibres decompose easily so, in time, irreparable losses are due to being disregarded for a very long time and considered a by-product or having an insignificant function. As such, the problem of a textile overproduction or the waste that cannot be destroyed in a reasonable period of time has never been raised until recent times.

In relation to architecture, textiles were classified into the Decorative Arts department, thus being studied more by Art historians than architects. Also with few exceptions, mainly of vernacular architecture – and I refer here to tents, object that we can find in various forms on all continents – textiles were indeed used as decorative pieces, at least for the exterior space. For the interior space, I consider that there are some categories with architectural potential - i.e. having defining characteristics such as: shape, color, texture, weight/importance as a whole -, and that have been used as such together with lighting in order to define the interior space [2]. These categories are:

1. The carpet
2. The tapestry
3. The wallpaper, curtain, drapery, room dividers
4. The upholstery materials.

The author interest in textiles dates back for many years but the official date of starting a scientific research is 2000, when it began the PhD research "Textiles in Arredamento". Back then, one could barely find scientific literature about the textiles relation with and implication in Architecture.

For the German speaking world, since the middle of the 19th century, there was a significant theoretical reference though. Gottfried Semper, a German architect and theorist, son of a wool manufacturer, approached the subject in his book "The Four Elements of Architecture". Semper developed the theory according to which out of the four elements of architecture – hearth, roof, enclosure and mound -, the enclosure is the source from which the *wall fitter* (*Wandbereiter*) evolved [3]. He also states that "it remains certain *that the beginning of the building coincides with the beginning of textiles*" [3]. His background of being exposed to the textiles' world from a young age, helped him understand the nature and characteristics of textiles, while he recognized his technical limits in the field. Being (partially) translated into English in 1989, his book offered a valuable (re)source in studying the theoretical textiles-architecture relation.

Semper also is gathering all the textiles used for the interior space into one term: *Bekleidung* [3] (dress the house/building). He considered that the primitive wall as wickerwork or braided branches developed into a *carpet wall* in the nomads' tents, and in his time tents were the only exterior architectural expression of the textiles, apart from occasional decorations. One can remark that a similar expression, "dressing the house", is used in the Romanian popular culture, referring to the same ensemble of interior textiles, with many typologies and used to make an elaborate decorative system, especially for the "good room" or "clean room" - "*the current term used to denote their arrangement is to dress*" [4].



Figure 1. The "good room" dressed, paysan house from Dorna Căndreni, Suceava county, Romania, end of 18th c. Now in the Museum of Bucovinean Village, Suceava. Photo B.G. Jöger.

In December 2006, Marc Garcia was the editor of the *Architectural Design* magazine issue dedicated to architecture and textiles, and there he coins the term "Architextiles". Garcia says that "A hybrid of 'architectures' and 'textiles,' the word 'architextiles' refers to this body of projects and the ways of thinking and making that join the two." [5]. The groundbreaking issue of AD proposed several insights from renowned architects who, in a more evident or disguised manner, were interested and used textiles in one or more of the four categories in which Garcia proposes to divide the Architextiles with which the architects operate [5]:

1. Used as metaphor from textiles or textile-based processes in architecture;
2. A textile-like spatial structure or form is produced in architecture;
3. Textiles as such, or composites and hybrids are used in the actual construction;
4. Architecture engages with textile through text.

Of course this categorization do not exclude the possibility of other types of engagement between the two fields, but we considered it as a base for the examples' analysis in the present paper.

## 2. METHODOLOGY

The present paper summarizes the author's interest and decades long research on textile materials and their relationship with the architecture and especially the interior architecture. During the research, mainly two methods were used: 1 - bibliographic study based on books, articles in journals and conference proceedings, which brought theoretical support and 2 - on site documentation about the present state of the art in the field by active participating in workshops, conferences, symposiums and field's fairs, where the latest research is presented and/or tested.

The paper will present examples analyzed by the author - for the historical part, the analysis of existing buildings - for the part of interpretation of theories, and examples of contemporary textile materials used in architecture - for the part dedicated to the 21st century.

### 3. SOME OLD STORIES

As no other means of image reporting and reproduction existed in old times, we must rely on the materials that have lasted through centuries: ceramics and stone. Greek pottery images and Traian's column metops (for example the metop no. 10) shows us some of the few authentic images of the ancient architectural use of textiles as tents.

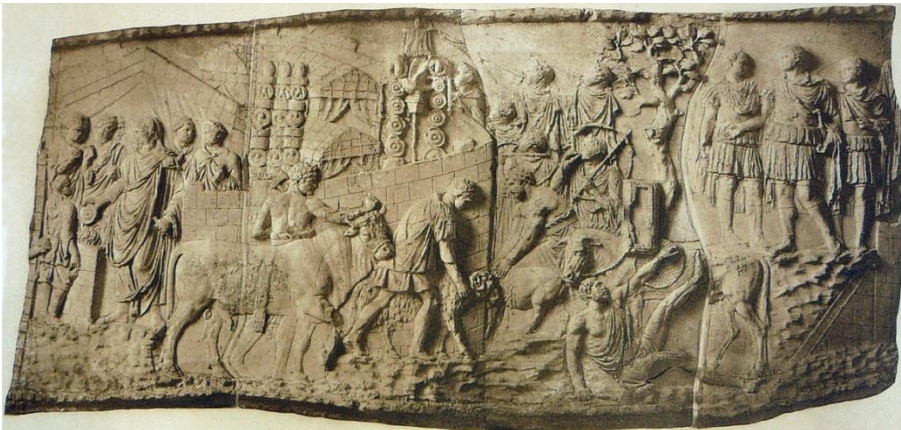


Figure 2. The relief of the Trajan Column, metop no. X. Source: [https://commons.wikimedia.org/wiki/File:010\\_Conrad\\_Cichorius,\\_Die\\_Reliefs\\_der\\_Traianssäule,\\_Tafel\\_X.jpg](https://commons.wikimedia.org/wiki/File:010_Conrad_Cichorius,_Die_Reliefs_der_Traianssäule,_Tafel_X.jpg)

As for the craft itself and interior textiles, for these there is a much richer source of ancient images, starting with those in Egypt and continuing with Greece and Rome.

The Middle Ages was a period when the textiles were ubiquitous. In the Western culture, to which I refer, we can find them both in public/official as well as in the private environments, with a predominantly local production for the lower classes and the resort to imports of materials and precious objects for the upper, wealthier, classes.

Regarding the imagistic of the Middle Ages we can notice today the serenity with which the authors of those times used their contemporary appearance to describe characters and architectures that often referred to events and places existing hundreds or thousands of years before. The textiles with a spatio-architectural role are represented in detail, the tents are especially military, and the interior textiles have a wide variety of forms under which they appear, from drapes and curtains to cushions and bed sheets, from upholstery to the more complex canopy beds. It should not be forgotten that the textile drapes or tapestries were used instead of the interior doors (if case) in most private buildings, being employed as such until late in the seventeenth century.





Figure 3. Tent representation in the third quarter of XVth century: Master of the Jardin de vertueuse consolation, illuminator, "Alexander's Illness at the Cydnus River and the Death of Sisinnus", French and Flemish, about 1470–1475, Ms. Ludwig XV 8 (83.MR.178), fol. 41. J. Paul Getty Museum.

During Middle Ages the interior textiles categories are enriched with the tapestry one, which was to be elevated to art. The cold and humid castle halls build in stone were difficult to warm, the only source of heat being the open chimney, the most inefficient means of heating a space. Thus, the hanging along the walls of wool fabrics has contributed to reducing the humidity of the air (wool being a good absorbent), to the reduction of the cold sensation, by creating an insulating air layer between the upholstery and the wall, and, likewise, to increase visual, psychological and aesthetic comfort for those who lived in the respective spaces. Another textile object of that time is the canopy bed. Through building a room within a room it was easier to heat it before bedtime, with the heaters (which looks like a pan with lid, in which ardent charcoal was placed and it was moved between sheets), and, as well, to retain the heat released by those who slept there. An additional advantage was that it brought a bit of intimacy to the bed occupants, towards the servants who usually slept at the bed side of on the cassone near it.



Figure 4. Royal canopy bed and tapestries hanging on the walls in the Cámara Regia at the Alcázar de Segovia, c. 1450, Spain. Photo B.G. Jöger.

At the same time, the commercial relationship with the Far East has developed along the Silk Road and other routes. The name of Silk Road, is a clear reference to the age and importance of this material and its trade, which connected the East with the West for millennia. Along with silk, over time, another luxury object came to Europe, the knotted carpet, which began to be introduced to royal courts, noble families and great bourgeoisie. The carpet becomes an important element for the interior space, a precious one, at first, being used with great care, as having a high economic and decorative value and being used as an expression of social status. Laid on tables and chests or hung, the carpet get to be "stepped on" only much later and often solely in dedicated spaces or at ceremonies. The establishment of European carpet manufactures, which took over the Eastern techniques (France, England) or innovated (Spain), represented not only a step in economic development but also that an object was to become more and more important in defining the interior space from a compositional and chromatic point of view.

Before moving on to the modern era, an innovative architectural approach from the Enlightenment century must be mentioned. This refers to the British architect Robert Adam who, together with his brothers John and James, elaborated in the last part of the 18th century the Adam Style. According to the current nomenclature of the occupations he was not only an (neoclassical) architect but also interior designer and furniture designer. The cumulation of these professions is extremely important due to the approach, for the first time, of the architectural object as a whole, the architect having the role of project manager and corroborating all the specialties. This was extended by Adam to the treatment of interior spaces, paying special attention to the compositional-chromatic coordination of the architectural elements, including the textiles with architectural role (carpets, tapestries, upholstery), which were specially designed in harmony with architecture.



Figure 5. Arch. Robert Adam, Tapestry Room, Osterley Park House, London. Source: <https://www.nationaltrust.org.uk/visit/london/osterley-park-and-house/the-house-at-osterley-park#rt-the-tapestry-room>

## **4. THE MODERN ERA**

### **4.1. The 19th century**

Advancing now through the 19th century, as I already mentioned Semper and his theory, one can not help to remark that his writings were published in 1851, an important year for the history of architecture as it marks (officially or not) the birth of the "architecture of the engineers", through the building in London of the Crystal Palace, by Joseph Paxton and Charles Fox as structural engineer, for the Great Exhibition of the Works of Industry of All Nations.

The second half of the 19th century was an effervescent period for arts and architecture, by renewing them through the Arts and Crafts Movement and then through Art Nouveau, with its multiple expression variants specific to each country. Like Robert Adam one century before, the creators completely and complexly approached a building, treating with the same attention all its elements, from the compliance of the volumetric-spatial to the furnishing of the space created with the necessary objects. Of course, in this context textiles were treated as an integral part of the architecture object, resulting in unitary and harmonious architectural works. We can mention here a few names of complete creators: the English William Morris and Charles Rennie Macintosh; the Belgians Victor Horta and Henry van de Velde; the French Louis Majorelle; the Austrian Josef Hoffman.

### **4.2. The 20th century**

Art Nouveau also represents the stylistic passage towards the 20th century, both in the field of architecture and in textiles.

We cannot omit to mention, for the first part of the 20th century, the Bauhaus School, which came with a fresh approach to architecture education. For about 15 years, it represented the avant-garde in the integration of theoretical with the practical education, by including the craft workshops. Thus, the arts associated with architecture have not been regarded as minor ones, but as elements that are part of it, contributing with equal rights to the configuration of spaces and objects that surround us.

The 20th century also represented a period of significant technological development that contributed to the intersection and cooperation between the two fields. We can only think about the invention of synthetic fibers by oil processing, used today widely in the field of architecture/construction, that has been a turning point for textiles. Not only because these are hardly degradable, and therefore - from the perspective of today's concerns - they are unsustainable, but also because they have brought the possibility of manipulation - today at the nanomolecular level - of their properties and implicitly of the resulting materials.

In order to exemplify the categories stated by Garcia I will present – chronologically - for the first three, some architectural examples. Addressing the fourth category - working with words and texts - would need a paper itself, although some mentions will be indirectly made to it.

Long before Marc Garcia established the term "Architextiles", Frei Otto, a German architect and engineer started to apply, during the 1950-es, the tensile properties of textiles in designing temporary and rapid building shelters. He then used a similar space structure reinterpreting a possible architectural form with other materials (steel and plexiglas). Thus, he managed to enlarged it to the scale of the impressive

Olympic Complex from Munich, in 1972. Looking from afar, the buildings of the complex look like tents. The surfaces of the double curved roofs, fixed with poles and cables, are revealed to be from plexiglass and steel only when approaching and roaming around to discover the complicated structural network that gives them life.



Figure 6. Olympic Complex, Munich, 1972. Arch Frei Otto. Photo B.G. Jöger.

Some forty years later, in 2013, was inaugurated the Library of Birmingham, designed by the Netherlands based architectural firm Mecanoo. Although the official description on the company's website refers to the metalwork past-related of the city, the outer skin can be metaphorically reinterpreted as a lace, a metallic watermark whose decorative leitmotif alludes to the Shakespeare Memorial Room built by John Henri Chamberlain in 1882, and now relocated within the building. The very words used by Mechanoo are also part of the textiles vocabulary:

*“Visitors move from one floor to the next through interconnected and overlapping rotundas that provide natural light and ventilation. Ever-changing vistas unfold through the delicate filigree skin of interlocking circles, inspired by the tradition of metalwork in this former industrial city.”* [6]

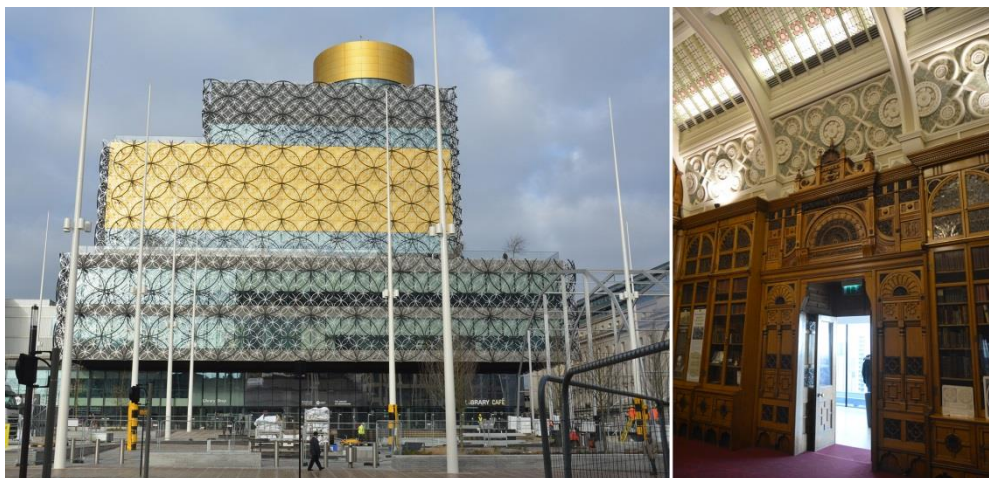


Figure 7. The Library of Birmingham, UK, 2013. Arch. Mecanoo and the Shakespeare Room by J.H. Chamberlain, 1882. Photo B.G. Jöger.

The third example is using the newest technologies to build for the future. The Maison Fibre, as it is called was presented at the Venice Architecture Biennale in 2021 and it was trying to give an answer to the generic question: "How will we live together?". The project was realized especially for the biennale by a team led by Achim Menges and Jan Knippers from Stuttgart that reunited specialists from several countries and two institutes of excellence [7]. The name of the project was "Material culture. Rethinking the physical substrate for living together" and the result of the research by project was the reinterpretation of the act of intertwining of the threads, as if going back to Semper's theory, but with 21st century materials: glass fibers, carbon fibers and epoxy resin, resulting in an amazing lightweight self-supporting structure, with the load-bearing elements of only 9kg/sqm. The combination of fibres is inspired by nature, where "almost all biological, load-bearing structures are made from fiber composites" [8].

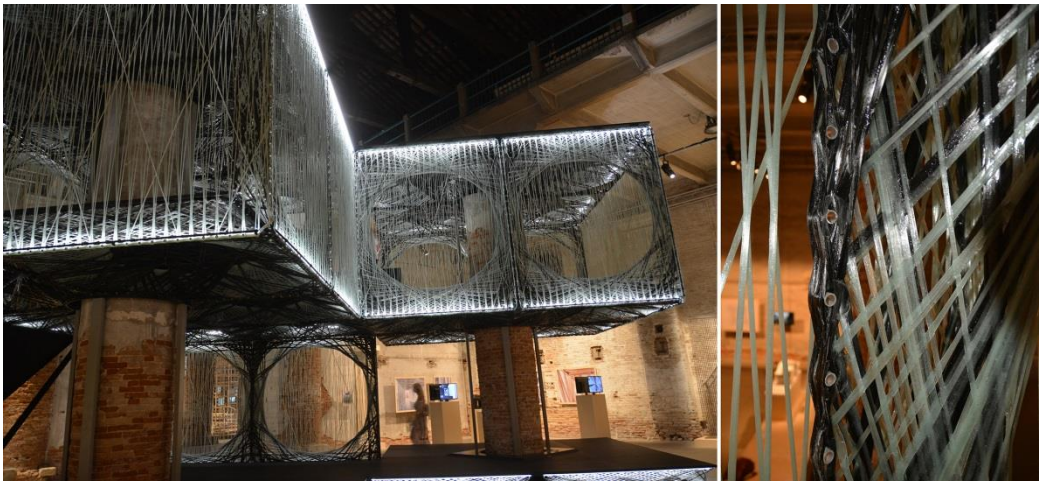


Figure 8. Maison Fibre, Venice Architectural Biennale, 2021, general view and structural detail. Arch. Achim Menges, Jan Knippers and teams from ICD Institute of Computational Design and Construction and ITKE Institute of Building Structures and Structural Design, Cluster of Excellence IntCDC, University of Stuttgart. Photo B.G. Jöger.

#### 4.3. The 21st century: in [re]search for new materials

The great Romanian poet Mihai Eminescu says in the poem "Glossa": "Time is passing, time comes yet,/ All is old, and all is new", which can be applied in some way to textile materials.

The textile industry is one of the largest consumers of physical, economic and even human resources. Thus, research in this field is oriented both towards improving the qualities of textile materials or that can be instilled to them, and to the discovery of new sources of raw materials or the revaluation of traditional ones, always having in mind the sustainability and ethics of production. Many of today's results are due to the use of nanotechnology, widely present in most industry areas. It allows, by introducing or applying small quantities of active substances, to obtain permanent or long-term results.

Probably one of the best known examples of application of nanotechnology is the treatment with silver ions. Although silver is not the only used element, it has returned to intensive use in the last two decades, as a natural sterilizer agent, from appliances

(especially refrigerators, washing machines) to textile materials, both for clothing and interior. Along with silver are used other minerals (aluminum for example, and acids - citric) which by chemical reactions contribute to the elimination of unpleasant aspects of our lives. These chemical catalysts (metal salts) integrated into fiber, through air circulation break down noxes into harmless components. Thus, unpleasant odors like sweating or nicotine can be removed.

In the following, I will briefly present some current examples of use and integration of fibers and textile materials in the field of architecture, using different technologies:

- Hemp concrete (Hempcrete) [9] - has been used for years in the UK and Canada. Construction material composed of a biofiber (hemp) and a mineral binder (lime) has a certain porosity, due to air holes, which give it special thermo-insulating properties and, in addition, a zero carbon imprint.
- Basalt fiber concrete reinforcements - a natural element, which is not harmful to the environment, and so neither for humans (Basalt Fibertec GmbH).



Figure 9. Basalt fibres, rebar and reinforcing net, Basalt Fibertech. Photo B.G. Jöger.

- Textile reinforced concrete double-curved envelope building - was realized with fiberglass fabric and elastomer for 3D concrete reinforcement (CurveTex, 2019, Paderborn, Penn Textile Solutions and Stanecker Betonfertigteilewerk).
- Reinforcement variants for plaster (Mehler Engineered Products GmbH).
- Knitted basalt material – SEAL protects marine systems such as beacons from environmental influences. Presented for the first time in 2017, it is already applied, reducing maintenance costs by up to 40%. (Helmut Peterseim Strickwaren GmbH & Noviatex GmbH).

Concrete with optical fibres - LITRACON™ is a translucent block made of optical fibres (4%) and concrete (96%) (Litracon and Byzance Design).

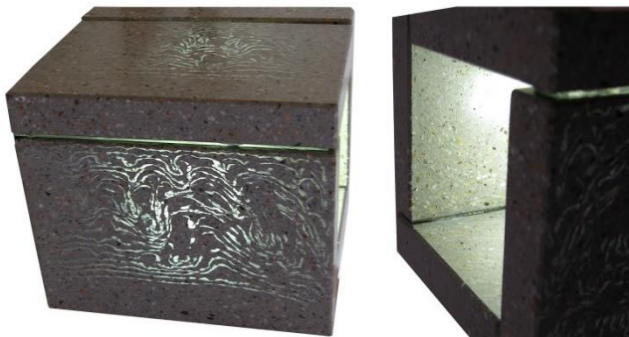


Figure 10. LITRACON™ cube. Photo B.G. Jöger.

- Self-cleaning facade - it was invented by Jan Serode (Aachen University) in collaboration with ECE Europa Bau - Und Projectmanager in Hamburg [10]. Made of a polyester fabric covered with a layer of titanium oxide, which transforms the noxis into neutral salts which can be washed by rain, one can foresee that in the near future, the facades of buildings will be able to act as atmospheric filters.
- Sustainable composite material made from pure cellulose - PURCELL, is used as a high-strength reinforcing fiber and as a matrix component (Institute of Textile Chemistry and Chemical Fibers Denkendorf).



Figure 11. Transformation of wood into PURCELL. Photo B.G. Jöger.

- Textile material produced from cork - CORK-A-TEX (Sedacor, Portugal) has a cork flexible yarn, obtained from the waste (that is normally burned) resulted from the process of cork objects. Can be used in interior design.
- Textiles with optical fibres - stimulated the designers to create innovative products: curtains that light, furniture pieces with integrated light (FLT Future Lighting Technologies GmbH).
- Compostable dispersion based on organic textiles and inks - invented by Centexbel to o remove some of the harmful components of the film coating and textile printing procedures. The method works very well with two types of natural polymers: PLA (polylactic acid - bio sugar polymer) and PHA (polyhydroxialkanoat - natural bacterial polymer). Dispersion does not require solvents and degrades over time without emitting harmful particles to the environment. It can be used in many products for both interior and packaging. (Wallpaper, flavor-based insulating composites, carpet doubles, artificial leather, food packaging).

## 5. CONCLUSIONS

As the title of the paper says (and Semper), it is a millennial story, not only of the past millenia, but of the present one and of the ones to come. We learn and re-learn to creatively use natural raw materials, because due to industrialization and mass production requirements, some of the traditional knowledge have been disregarded. Even though the natural raw materials are almost the same, we, people, had the ingenuity and the intelligence to perfect our technologies in order to obtain more products with richer capabilities using less resources.

From the wicker work, going through tents, carpets and curtains, due to the advanced technology at our reach today, textiles are establishing themselves into the architectural realm with a new attitude and new capabilities. Their known

qualities such as the low weight, the flexibility, the possibility of folding, the easy mounting and disassembly, are the ones that make them more and more sought after and used in the architecture. The textile envelope, for example, is the perfect response to the organic sculptural forms modeled by the parametric software, forms for which today there are textile materials capable of meeting the complex requirements of a building.

Through the technologies of the present and the ones we can only foresee for the future, textiles and architecture are closely tied, continuing to weave their threads into a common future.

## REFERENCES

- [1] Kvavadze Eliso, Bar-Yosef Ofer, Belfer-Cohen Anna, Boaretto Elisabetta, Jakeli Nino, Matskevich Zinovi, Meshveliani Tengiz: **30,000 Years old wild flax fibers - Testimony for fabricating prehistoric linen**. *Science* 325 (5946), 1359. 2009.
- [2] Jöger Beatrice-Gabriela: **Materialele textile în arredamento - Surse și istorie** (Textile materials in interior space design - Sources and history). *Editura Universitară „Ion Mincu”*, Bucharest, 2006.
- [3] Semper Gottfried: **The Four Elements of Architecture and Other Writings**. *Cambridge University Press*, Cambridge, 1989.
- [4] Stoica Georgeta, Horșia Olga: **Meșteșuguri artistice tradiționale** (Traditional Artistic Crafts). *Editura Enciclopedică*, Bucharest, 2001.
- [5] Garcia, Marc. **Architecture + Textiles = Architextiles**. *Architectural Design*, Vol. 76, no. 6, 7, 2006.
- [6] <https://www.mecanoo.nl/Projects/project/57/Library-of-Birmingham?d=1&t=1>. (24.05.2022.)
- [7] **Data from the exhibition panels at the Venice Architecture Biennale 2021**: Achim Menges (German, b.1975) with Niccolò Dambrosio (Italian, b.1988), Rebeca Duque Estrada (Brazilian, b.1989), Fabian Kannenberg (German, b.1991), Katja Rinderspacher (German, b.1978), Christoph Schlopschnat (German, b.1988), and Christoph Zechmeister (Austrian, b.1985) of ICD Institute of Computational Design and Construction (Germany, est.2008), Cluster of Excellence IntCDC at the University of Stuttgart, and Jan Knippers (German, b.1972) with Nikolas Früh (German, b.1987), Marta Gil Pérez (Spanish, b.1986), Riccardo La Magna (Italian, b.1982) at ITKE Institute of Building Structures and Structural Design (Germany, est.1950), Cluster of Excellence IntCDC, University of Stuttgart.
- [8] VAB - **Data provided by the authors of the project** on the exhibition panels at the Venice Architecture Biennale 2021.
- [9] Magwood, Chris. **Essential Hempcrete Construction, The complete step-by-step guide**. *New Society Publishers*, Canada, 2016.
- [10] <https://www.techtextil-blog.com/en/textile-facade-soaks-up-pollutants-from-the-air/>. (03.07.2020.)



# SULFATE RESISTANCE OF GEOPOLYMER CONCRETE PRODUCED WITH HAZARDOUS WASTE VITREOUS ENAMEL GENERATED IN THE PRODUCTION PROCESS OF HEATING DEVICES

Nenad Ristić<sup>1</sup>, Jelena Bijelić<sup>2</sup>, Dušan Grdić<sup>3</sup>, Gordana Topličić-Ćurčić<sup>4</sup>, Zoran Grdić<sup>5</sup>

## Abstract

*This paper presents the research of the effects of addition of hazardous waste vitreous enamel material generated in the production of heating devices on physical-mechanical characteristics and sulfate resistance of geopolymer concrete based on fly ash. Five geopolymer concrete mixes were made with a different share of vitreous enamel material in the amount of 0% to 40% by mass with a step of 10%. Up to testing, geopolymer samples were cured in ambient conditions at a temperature of 20°C±2°C protected from the loss of humidity. Concrete samples were exposed to the effect of sulfate solution for one year. Based on the test results, all geopolymer concrete mixes showed good sulfate resistance. The highest resistance coefficient was measured on the mixtures with 100% FA and 10% VEM, while sulfate resistance slightly decreased with increasing waste enamel content.*

**Key words:** *geopolymer, concrete, vitreous enamel material, fly ash, mechanical properties, sulfate resistance.*

---

<sup>1</sup> PhD, Assoc. Prof., University of Niš, Faculty of Civil Engineering and Architecture, nenad.ristic@gaf.ni.ac.rs

<sup>2</sup> PhD, Academy of technical and educational vocational studies Niš, jelena.bijeljic@akademijanis.edu.rs

<sup>3</sup> PhD, Assis. Prof., University of Niš, Faculty of Civil Engineering and Architecture, dusan.grdic@gaf.ni.ac.rs

<sup>4</sup> PhD, Prof., University of Niš, Faculty of Civil Engineering and Architecture, gordana.toplicic.curcic@gaf.ni.ac.rs

<sup>5</sup> PhD, Prof., University of Niš, Faculty of Civil Engineering and Architecture, zoran.grdic@gaf.ni.ac.rs

## 1. INTRODUCTION

The rapid development of industry as well as a constant need for new and more advanced products has resulted in the generation of large quantities of waste, and its quantities can be measured in millions and billions of tons.

Depending on the nature of the waste, its properties, and its origin, different methods of disposal are used, i.e., different types of secured landfills, such as open, controlled, and closed. In the case of non-hazardous waste, it can be returned to the production process using appropriate technologies with reasonable investments, which is followed by low-cost production of end products, so that, besides environmental gains, economic benefits may be achieved [1].

A more significant environmental problem is hazardous waste. The main problems with it are composition and characteristics. Also, obtaining useful value and removal from the environment without a large investment. There is only a small number of plants where hazardous waste can be treated, which means that transport and management are expensive. For mentioned reasons, it is important to find a way to treat this kind of waste with minimal investments [2]. Some possibilities of immobilization of hazardous waste in its application in the construction industry, are actually in the production of cement, mortar, and concrete. Immobilization of hazardous waste was poorly investigated [3-8]. Since then, only a few authors investigated the application of the hazardous waste vitreous enamel generated in the production process of heating devices as a partial replacement for the production of cement-based materials. M. Kragović et al. [9] and J. Gulicovski et al. [10] investigated the application of waste vitreous enamel as a cement replacement for up to 30 % in cement mortar and concrete production. Obtained results of research that used waste material are hazardous, but with good pozzolanic properties. According to the mechanical properties of mortar and concrete, the authors indicated that waste vitreous enamel could be applied as a construction material for cement replacement for up to 20 % of binder mass.

Ristić et al. [11] investigated the effects of waste vitreous enamel on the physical-mechanical properties of geopolymer concrete based on fly ash. The results showed that the replacement of fly ash by waste vitreous enamel up to 20% does not affect the significant decrease in the mechanical characteristics of geopolymer concrete. In the continuation of the research, the durability characteristics of geopolymer concrete were examined. This paper showed the results of the examination of sulfate resistance of geopolymer concrete based on fly ash (FA) with addition hazardous waste vitreous enamel generated (VEM) in the production process of heating devices at the company Alfa Plam Vranje.

## 2. MATERIALS AND METHODS

### 2.1. Used materials

In this study fly ash was used as the main source material for making geopolymer concrete while VEM was used as an additive. FA originates from thermal electric power plant Kostolac "B" – Serbia. VEM was generated in the heating process of production heating devices by the company Alfa-plam Vranje, Serbia. Chemical

compositions of FA and VEM are given in Table 1, while in Figure 1 their photograph and SEM are displayed.

Table 1. Chemical composition of used binders

Material	SiO <sub>2</sub>	Fe <sub>2</sub> O <sub>3</sub>	Al <sub>2</sub> O <sub>3</sub>	CaO	MgO	SO <sub>3</sub>	P <sub>2</sub> O <sub>5</sub>	TiO <sub>2</sub>	Na <sub>2</sub> O	K <sub>2</sub> O
FA / %	51.68	11.58	20.16	7.42	2.41	1.02	0.12	1.04	0.88	1.04
VEM %	21.62	2.60	7.00	60.16	2.34	2.55	-	-	0.33	0.66



Figure 1. Photo and SEM display of used binder materials: FA (up), VEM (down)

Sodium hydroxide and sodium silicate were used as alkali activators for making geopolymer mixtures. Sodium hydroxide of molarity 10M was mixed with sodium silicate of the starting module  $M_s 2,2$  ( $M_s = \text{SiO}_2/\text{NaO}$ ). That way, an activator with the content of 10% Na<sub>2</sub>O of the solid binder mass was obtained, whereas  $M_s$  in sodium silicate was reduced. A solution prepared this way was used for making all geopolymer mixtures.

Standard tap water was used in mortar production in all mixtures. The aggregate used in this research was river sand that originated from South Morava (Serbia) with a maximum grain size of 2 mm and rock aggregate that originated from „Rakov dol“ of grain size 4/8 mm.

## 2.2. Mix design

Five geopolymer concrete mixtures were marked as “0 V”, “10 V”, “20 V”, “30 V”, and “40 V”. In mentioned mixtures, waste vitreous enamel material was used to replace fly ash at 0%, 10%, 20%, 30% and 40% by weight, respectively. The mix proportions of geopolymer concrete mixtures are given in Table 2. The moulds with samples of geopolymer were after demoulding, and until the testing, wrapped in a plastic foil to prevent moisture loss.

All geopolymer mixtures were made by using the same ratio of water/binder and binder/aggregate per mass. The samples prepared in this part were cured at ambient temperature. All batches of geopolymer mixtures were made on the basis of fly ash with particles smaller than 0.09 mm, with added waste vitreous enamel material of particles smaller than 0.09 mm.

Table 2. Mix proportion of geopolymer concrete

Mixture	0 V	10 V	20 V	30 V	40 V
Fine aggregate /g	750	750	750	750	750
Coarse aggregate /g	750	750	750	750	750
Fly ash/g	405	364.5	324	283.5	243
Vitreous enamel /g	0	40.5	81	121.5	162
NaOH (10M)/g	50.54	50.54	50.54	50.54	50.54
Na <sub>2</sub> SiO <sub>3</sub> /g	272.91	272.91	272.91	272.91	272.91

### 2.3. Methods

Testing the flexural and compressive strength of geopolymer concrete mixtures was performed according to the SRPS EN 196-1 standard. The testing was performed at the concrete sample age of 2, 7, and 28 days. The flexural strength was tested on three samples having the form of a 40×40×160 mm prism, while the compressive strength was determined on the halves of concrete prisms.

Sulfate resistance of geopolymer mortars based on FA with the addition of VEM was tested by using the performance testing report CEN/TR 15697. The samples of geopolymer concrete, until the age of 28 days were cured in ambient conditions wrapped in a plastic foil. After achieving age of 28 days the samples of geopolymer concrete were completely immersed in Na<sub>2</sub>SO<sub>4</sub> solution of 5% for one year. According to the testing report the samples are considered resistant to sulfate action if the ratio of compressive strength and reference samples of the same composition is higher than 80% (resistance coefficient higher than 0.80).

## 3. RESULTS AND DISCUSSION

The flexural and compressive strength testing results of the geopolymer concrete mixtures based on fly ash and with the addition of waste vitreous enamel material are provided in Figures 2 and 3.

The flexural strength test results of the geopolymer concrete mixtures are shown in Figure 2. Each value presented is the average of three measurements. According to the flexural strength test results at the age of 2 and 7 days, it can be concluded that the addition of waste vitreous enamel material has a negative impact on the flexural strength of concrete. At mentioned ages, mixtures made with a lower mass percent of VEM achieved higher flexural strengths than mixtures made with a higher mass percent of VEM. However, at the age of the samples of 28 and 365 days, the difference between the flexural strength values of the reference mixture and the mixtures with the addition of VEM in the amount of 10% and 20% decreased significantly. That difference amounts to 6.3% and 10.4% respectively, at the age of the samples of 365 days.

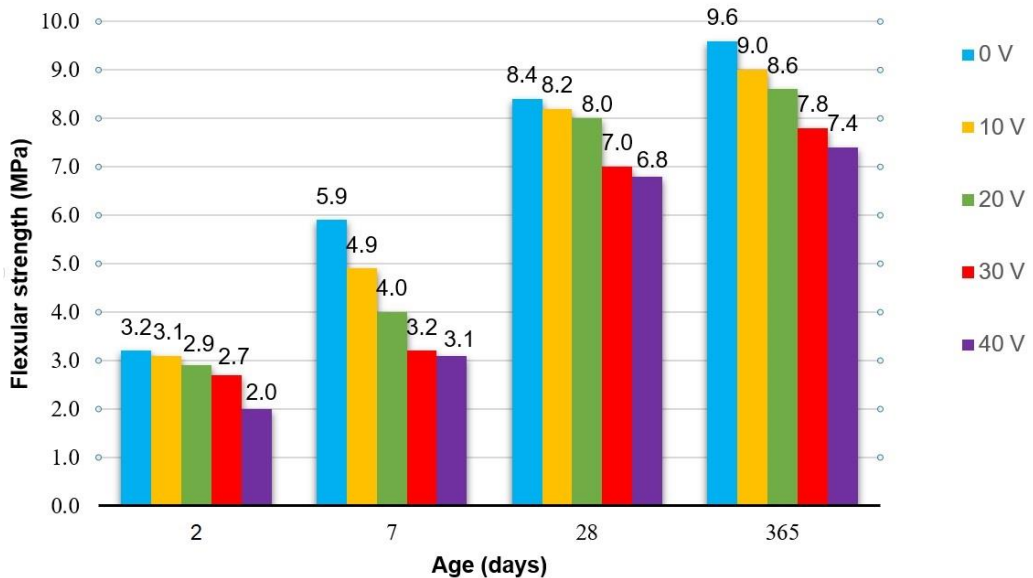


Figure 2. Flexural strength of geopolymer concrete

At all ages, the highest value of compressive strength has the geopolymer concrete mixture designated as „0 V“. The mixture with 10% waste vitreous enamel has slightly lower compressive strength than the reference mixture at all ages. At the age of 365 days, that difference amounts to 9.8%. As the VEM content increases, the compressive strength decreases significantly.

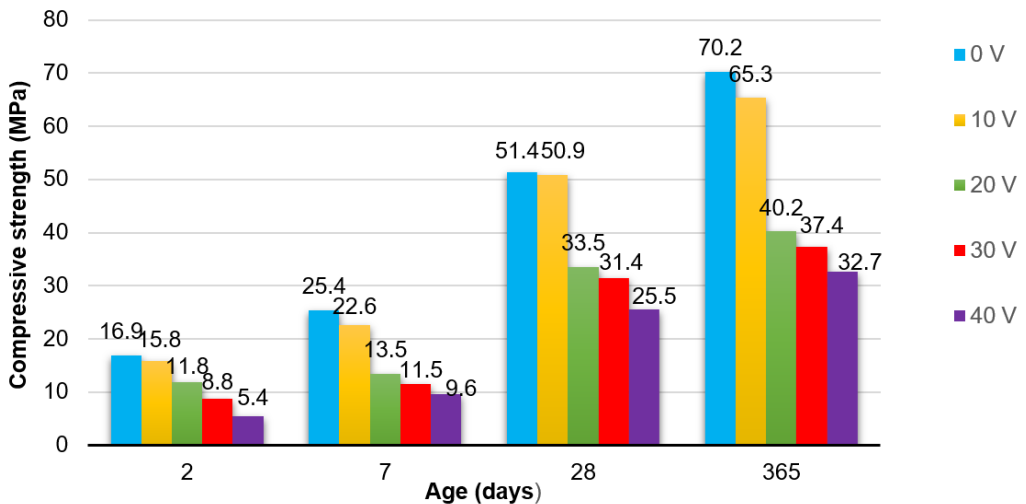


Figure 3. Compressive strength of geopolymer concrete

In Figure 4 and 5 are presented test results of flexural strength and compressive strength resistance of geopolymer one year of immersion in 5% Na<sub>2</sub>SO<sub>4</sub>. The test results of geopolymer concrete indicate good sulfate resistance under the implemented test requirements. In terms of flexural strength, the sulfate resistance coefficient is higher than 1 for mixtures 0V and 10V, while for mixtures 20V and 30V coefficient is higher than 0.80. Only the 40V mixture does not meet the required

requirement. In terms of compressive strength, the sulfate resistance coefficient is higher than 0.80 for all mixtures. The highest resistance coefficient was measured on the mixture marked as 0V, while sulfate resistance slightly decreased with increasing waste enamel content. Physical changes on the tested samples were not observable. Good resistance of geopolymer concrete on the sulfate effects is accounted for by the fact that the process of polymerization continues unimpaired even after exposing the samples to aggressive action of sulfate solution.

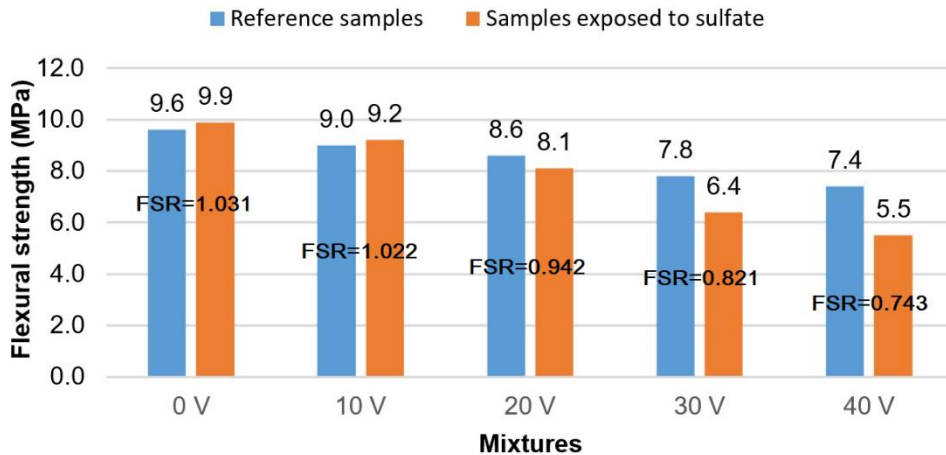


Figure 4. Flexural strength resistance (FSR) after one year immersion in 5%  $\text{Na}_2\text{SO}_4$  solution

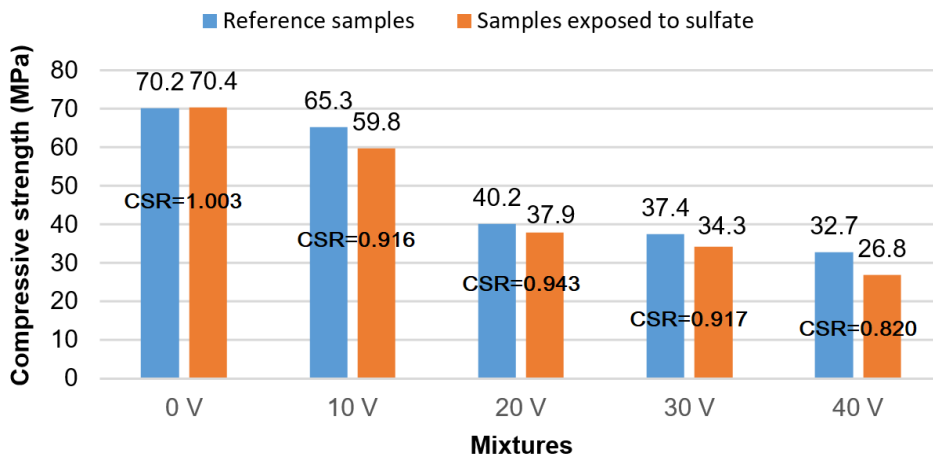


Figure 5. Compressive strength resistance (CSR) after one year immersion in 5%  $\text{Na}_2\text{SO}_4$  solution

#### 4. CONCLUSIONS

Based on the test results of geopolymer concrete based on fly ash with the addition of waste vitreous enamel, the following conclusions can be drawn:

1. The flexural strength of geopolymer concrete decreases slightly with increasing content of waste vitreous enamel. The drop in flexural strength compared to the reference concrete is from 6.3% to 22.9% at the age of the samples of 365 days.

2. Waste vitreous enamel does not affect an initial increase of compressive strength of geopolymer concrete mixtures, proportionally to the share percentage. Only the mixture with 10% waste vitreous enamel has slightly lower compressive strength than the reference mixture at all ages.

3. Generally, all geopolymer concrete mixes showed good sulfate resistance. The highest resistance coefficient was measured on the mixture with 100% FA, while sulfate resistance slightly decreased with increasing waste enamel content.

4. Environmental and economic advantages of using geopolymer materials are reflected in the use of waste material, whose CO<sub>2</sub> emission, when transforming it from a byproduct into a binder, is low.

5. It is necessary to test other durability properties of geopolymer concrete, such as resistance to freezing/thawing, water penetration under pressure, wear resistance, etc.

## ACKNOWLEDGMENTS

This paper has been supported by the Ministry of Education, Science and Technological Development through the project no. 451-03-47/2023-01/ 200095: "Innovative scientific and artistic research from the FTS domain".

## REFERENCES

- [1] Sharma, H.D.; Lewis, S.P.: **Waste Containment Systems, Waste Stabilization, and Landfills: Design and Evaluation**; John Wiley and Sons: New York, NY, USA, 1994.
- [2] Moser R.D., Allison P.G., Williams B.A., Weiss Jr. C.A., Diaz A.J., Gore E.R., Malone P.G.: **Improvement in the geopolymer-to-steel bond reducing a reactive vitreous enamel coating**. *Construction and building materials*, Vol 49, pp. 62-69
- [3] Kragović M., Ristić N., Gulicovski J., Nedeljković A., Pašalić S., Ristović I., Stojmenović M.: **Application of lignite combustion waste slag generated in heating plants as a partial replacement for cement. Part II: physical-mechanical and physical-chemical characterization of mortar and concrete**. *Minerals*, Vol. 11, pp. 925
- [4] Nedeljković A., Stojmenović M., Gulicovski J., Ristić N., Milićević S., Krstić, J., Kragović, M.: **Waste slag from heating plants as a partial replacement for cement in mortar and concrete production. Part I physical-chemical and physical-mechanical characterization of slag**. *Minerals*, Vol 10, pp. 992.
- [5] Mymrin V., Presotto P., Alekseev K., Avanci M.A., Rolim P.H., Petukhov V., Taskin A., Gidaracos E., Valouma A., Yu G: **Application of hazardous serpentine rocks' extraction wastes in composites with glass waste and clay-sand mix to produce environmentally clean construction materials**. *Construction and building materials*, Volume 234, 20 February 2020, 117319
- [6] Pitarch A., Reig L., Gallardo A., Soriano L., Borrachero M.; Rochina S.: **Reutilisation of hazardous spent fluorescent lamps glass waste as supplementary cementitious material**. *Constr and building materials*, Volume 292, 19 July 2021, 123424
- [7] Najm O., El-Hassan H., El-Dieb A.: **Ladle slag characteristics and use in mortar and concrete: A comprehensive review**. *Journal of cleaner products*, Volume 288, 15 March 2021, 125584

- [8] Lieberman R.N., Knop Y., Izquierdo M., Palmerola N.M., de la Rosa J., Cohen H., Muñoz-Quirós C., Cordoba P., Querol X.: **Potential of hazardous waste encapsulation in concrete with coal fly ash and bivalve shells**, *Journal of cleaner product*, Volume 185, 1 June 2018, Pages 870-881
- [9] Kragović M., Stojmenović M, Ristić N., Milićević S, Živković S., Liu S., Gulicovski J.: **Application of the hazardous waste vitreous enamel generated in the production process of heating devices as a partial replacement for cement**, *Buildings*, 2022, Vol. 12, 1287
- [10] Gulicovski J., Kragović M., Nikolić K., Rosić M., Ristić N., Janković-Častvan I., Stojmenović M.: **Possibility of Using Vitreous Enamel Waste in the Construction Industry as the Concept of Cleaner Production**, *Applied Sciences* 2023, 13(14), 8215
- [11] Ristić N., Bijelić J., Grdić Z., Topličić-Ćurčić G., Grdić D.: **Effects of hazardous waste vitreous enamel generated in the production process of heating devices on physical-mechanical properties of geopolymer concrete based on fly ash**, *Proceedings of XXVIII congress DIMK and IX congress SIGP with international symposium on researching and application of contemporary achievements in civil engineering in the field of materials and structures*, Divčibare, October 19-21, 2022., p.p. 273 – 282, ISBN 978-86-87615-10-6, COBISS.SR-ID 77064713



## SIGNIFICANCE OF NUMERICAL SIMULATION OF SOIL MEDIA IN SSI ANALYSIS OF FRAMES

Kemal Edip<sup>1</sup>, Vlatko Sheshov<sup>2</sup>, Julijana Bojadjieva<sup>3</sup>, Toni Kitanovski<sup>4</sup> and Dejan Ivanovski<sup>5</sup>

### Abstract

*In this study on the seismic interaction of soil-structure, the soil medium is typically considered as a large medium and constitutive relations are often assumed to be elastic. While linear soil modeling may provide reasonably accurate results for small deformations, it becomes less reliable as deformations increase. Therefore, it is essential to employ nonlinear material modeling of soil, particularly for seismic analysis, as small soil deformations are relevant only under low seismic excitation and become insignificant when analyzing soil-structure interaction phenomena.*

*In this research, the response of multi-storey frame structures is investigated using three different material models for the soil. The findings of the analysis indicate that, in addition to the structural properties and boundary conditions, the choice of soil constitutive relations significantly influences the outcomes of problems related to soil-structure interaction.*

*Overall, this paper underscores the importance of employing nonlinear material models for soil when studying seismic effects on structures. Understanding the behavior of soil under varying deformation levels is crucial for accurate analysis and design of structures subjected to seismic forces, ultimately leading to more reliable and effective solutions for soil-structure interaction challenges.*

**Key words:** *Soil-structure interaction, Numerical simulation, infinite elements*

---

<sup>1</sup> Prof., University "Ss. Cyril and Methodius" Institute of Earthquake Engineering and Engineering Seismology-Skopje, kemal@iziis.ukim.edu.mk

<sup>2</sup> Prof., University "Ss. Cyril and Methodius" Institute of Earthquake Engineering and Engineering Seismology-Skopje, vlatko@iziis.ukim.edu.mk

<sup>3</sup> Assoc. Prof., University "Ss. Cyril and Methodius" Institute of Earthquake Engineering and Engineering Seismology-Skopje, jule@iziis.ukim.edu.mk

<sup>4</sup> Assist., University "Ss. Cyril and Methodius" Institute of Earthquake Engineering and Engineering Seismology-Skopje, tonik@iziis.ukim.edu.mk

<sup>5</sup> Assist., University "Ss. Cyril and Methodius" Institute of Earthquake Engineering and Engineering Seismology-Skopje, ivanovski@iziis.ukim.edu.mk

## 1. INTRODUCTION

The constitutive modeling of soil media has long been a focal point of research and development within the domain of soil-structure interaction, drawing substantial attention from engineers, geologists, and researchers alike. In the past decades many attempts have been performed to develop constitutive models for modeling of soil media. Two major classes are available in the literature: linear elastic models and non linear elastic model in which stress-strain relations deviate from linearity. Particular emphasis should also be placed on addressing the concept of the failure envelope, as its comprehensive description plays an indispensable and pivotal role in the accurate simulation of soil behavior. The aim of this study is to present the newly implemented material models in finite element software ANSYS for simulation of soil medium in soil-structure interaction problems. Although in numerical calculations constitutive models are the most difficult and tricky part of the problem, there are some elementary features of the soil behavior which should be taken into consideration in most cases. Constitutive models are typically categorized based on their mathematical parameters, a classification that serves as a foundational framework for understanding and applying these models in various engineering and scientific contexts. For more detailed explanation the reader can refer to the following publications [1, 2]. Although the classification of the material models is useful for scientists it is still difficult for comprehension to the wider professional public. Therefore, model evaluation appears more useful for users of constitutive models in geotechnical engineering. Laboratory experiments involving soil specimens serve as essential tools for testing constitutive models and assessing fundamental soil characteristics, including but not limited to nonlinearity, irreversibility, failure criteria, and deformation history.

As given in the work of Herle [3] It is often a formidable challenge to encompass all relevant features using a single material model. In the work of Chi and Kushwaha [4] a non linear finite element model has been developed to study the soil failure by using the hyperbolic stress-strain model. Experiments conducted by Rowe and Peaker [5] show that both deformation mode and magnitude affect the distribution of earth pressure. Building upon the pioneering works of Drucker and Prager [6] on soil plasticity the trend has been to develop more precise and correct elastoplastic models for simulation of real materials. In the work of Loret and Prevost [7] different parameters are considered in solutions for the Drucker-Prager elasto-plastic material models. On the other hand development of von Mises [8] elastic plastic equations has enabled considerable improvement in simulation of soil materials. The variations in structural response, encompassing factors such as acceleration, displacements, and structural moments, are meticulously presented in tabular form, facilitating systematic comparisons for insightful analysis.

## 2. MODELING OF SOIL MEDIUM

In the context of finite element analysis, the integration of material models involves the application of constitutive equations at discrete integration points. Incremental analysis is employed, with the initial solution assumed to be known at the start of each increment. With knowledge of the strain increment ( $\Delta\varepsilon$ ), it becomes possible to calculate the stress at the end of the increment. However, the integration

of elasto-plastic models poses a challenging numerical problem due to the definition of plastic strain as a rate that occurs after the material's behavior has undergone a transformation at the yield point.

In this work in numerical modeling the soil in the soil-structure interaction problem is modeled as a non linear medium using the Drucker-Prager and Bilinear Isotropic (BISO) material models. In order to complete the investigation an elastic model of soil is also simulated for completeness of the comparison.

The frame structure is exposed to earthquake acceleration and the results compared accordingly. Then the non linear material models are compared with elastic soil medium and the results are discussed consequently. For more detailed explanation of the material models the reader is referred to [7, 9]. The calibration of the non linear material models for Bilinear and Drucker-Prager material laws is done according to the work of Kodama and Komiya [10].

The Bilinear Isotropic material model (BISO) uses the von Mises yield criteria coupled with an isotropic work hardening assumption. The material behavior is described by a bilinear stress-strain curve starting at the origin with positive stress and strain values. The initial slope of the curve is taken as the elastic modulus of the material. At the specified yield stress the curve continues along the second slope defined by the tangent modulus. The tangent modulus cannot be less than zero nor greater than the elastic modulus [11].

On the other hand the Drucker-Prager model uses the outer cone approximation to the Mohr-Coulomb law. The amount of dilatancy can be controlled with the dilatancy angle. If the dilatancy angle is equal to the friction angle, the flow rule is associative [11].

The soil medium is represented as a two-dimensional model, consisting of four layers situated above the bedrock. Table 1 presents the properties of these soil layers in a manner that highlights the improved soil characteristics of the lower layers.

Table 1. Material parameters in finite element analysis

Soil medium	Layer number	Thickness (m)	Density (kg/m <sup>3</sup> )	Elastic Modulus (kPa)	Friction angle (deg)	Uniaxial yield stress (kPa)
Elastic	1	3	1.1	2000		
	2	7	1.3	2200		
	3	6	1.5	2400		
	4	14	2	2600		
Drucker-Prager	1	3	1.1	2000	35	
	2	7	1.3	2200	35	
	3	6	1.5	2400	35	
	4	14	2	2600	35	
Von Mises	1	3	1.1	2000		0.1
	2	7	1.3	2200		0.1
	3	6	1.5	2400		0.1
	4	14	2	2600		0.1

The soil is discretized using eight noded plane strain elements PLANE82. The dynamic analysis is performed by transient analysis using the step by step method. The proportional viscous damping matrix is taken to be proportional to mass and stiffness matrix (Rayleigh damping). The Rayleigh damping factors, alpha and beta are calculated such that the critical damping is 5% for first two modes. The bottom boundary of the soil model is fixed while side boundaries are simulated as viscous boundaries.

### 3. COUPLED SOIL-STRUCTURE INTERACTION SYSTEM

To demonstrate the impact of soil material modeling on structural response, we conducted a comparative analysis involving three distinct cases. First the soil medium is simulated as an elastic material model. Then the same soil medium is simulated as nonlinear by considering the Drucker-Prager and BISO material models. In order to have a bigger range of results the frame is considered as one, three and five storey frames. The frame structural elements are idealized as two dimensional elastic beam elements BEAM3 having three degrees of freedom at each node, translations in the nodal x and y directions and rotation about the nodal z axis. The behavior of the frame structure is supposed as elastic and is modelled using two parameters, the modulus of elasticity  $E=3.15 \times 10^7$  kPa and Poisson's ratio  $\nu=0.2$ . The bay length of the frame is taken to be 4.0 m and storey height of 3.0 m. Section of beams is 40 x 50 cm while the column section is 50 x 50cm. A mass of 11 tons is assigned on each node to simulate the real structural behavior (total 44 tons per floor). For all RC frames the beam and column sections, floor

masses and number of bays are kept constant in all cases. The only parameter that is altered is the storey number.

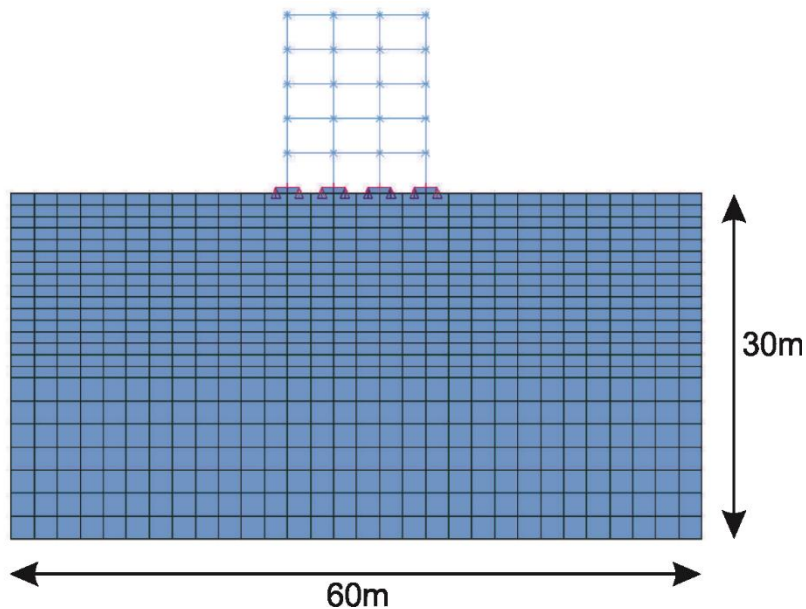


Figure 1. Coupled Soil-structuresystem of a five storey frame

Finite element modeling of the coupled soil-structure system is performed by the software ANSYS [11] as shown in Figure 1. The effect of soil-structure interaction is carried out with the acceleration time history of the El Centro earthquake with a scaled peak ground acceleration of 0.25g. The foundation where the structure is supported is taken to be 8 noded plane element having two degrees of freedom in each node, translations in the nodal x and y directions. The moment transfer capability between the column and the footing is created by using a constraint equation where the rotation of the beam is transferred as force couples to the plane element. In Table 2 below the difference in the structural response is given.

*Table 2. Structural values from the analysis of the frame structures*

No. of Stories	Soil Medium	Max. acceleration at the top of Str.(m/s <sup>2</sup> )	Max. displacement at the top of Str.(mm)	Max. moment at the top of Str.(kNm)
1	Elastic	2.54	9.44	28.5
	Drucker-Prager	2.77	9.33	25.6
	BISO	2.79	9.39	31.7
3	Elastic	2.60	4.89	2.02
	Drucker-Prager	2.60	4.08	4.03
	BISO	2.68	4.66	4.40
5	Elastic	2.55	5.67	2.75
	Drucker-Prager	2.60	5.57	5.49
	BISO	2.61	6.87	5.79

According to the acceleration values of the Table 2 the maximum acceleration at the top of structure is considerably big when using linear elastic material model. This illustrates that in soil medium analysis usage of elastic material model is not realistic and should be considered carefully. On the other hand, in using Drucker-Prager material model the maximum structural moment at top of structure has smaller values when compared with elastic material model. In moment comparison the usage of BISO model has similar values with the Drucker-Prager model although the deviation of the results is observed. When comparing the horizontal displacement at the top of structures it can be stated that in all cases of frames considered the Drucker-Prager model predicts the smallest values. In comparison of maximum acceleration values at the top of structures it can be concluded that the elastic material model has the biggest values while the usage of Drucker-Prager and BISO models vary accordingly. Hence, it can be asserted that when simulating soil behavior using non-linear material models, a critical step involves the calibration of parameters based on experimental data prior to the simulation.

#### 4. CONCLUSIONS

It is worth noting that within the existing literature, numerous examples exist where the performance of actual geotechnical structures has been compared. However, it's important to highlight that comparatively limited attention has been directed towards examining the influences of material modeling on the outcomes of these analyses. The major advantage of simulation of soil-structure interaction problems considering both soil and structure in single finite elements system is that the description of the soil model is both linear and non-linear which allows basic

mechanical responses to be predicted in a correct manner. Moreover, all parameters used in the model have explicit physical meanings and can be calibrated through laboratory tests. Conversely, it's important to acknowledge that the primary limitations of this model stem from its sensitivity to linear effects, which can result in overestimating the critical strength when subjected to high deformation values. The best algorithm of soil modeling is the one that combines computational efficiency with acceptable accuracy. Since analytical solution is not always available all elastoplastic models are implemented with some negligible error.

## REFERENCES

- [1] Darve, F., **Incrementally non-linear constitutive relationships.** *Geomaterials, Constitutive Equations and Modeling*, 1990: p. 213-238.
- [2] Cambou, B. and C. Di Prisco, **Constitutive modeling of geomaterials2000:** *Hermes Science Publications*.
- [3] Herle, I., „**On basic features of constitutive models for geomaterials**”. *Journal of Theoretical and Applied Mechanics*, 2008. 38(1-2): p. 61-80.
- [4] Chi, L. and R. Kushwaha, **A non-linear 3-D finite element analysis of soil failure with tillage tools.** *Journal of Terramechanics*, 1990. 27(4): p. 343-366
- [5] Rowe, P. and K. Peaker, **Passive earth pressure measurements.** *Geotechnique*, 1965. 15(1): p. 57-78
- [6] Drucker--, D., W. Prager, and H. Greenberg, **Extended limit design theorems for continuous media.** *Quart. Appl. Math*, 1952. 9(4): p. 381-389.
- [7] Loret, B. and J.H. Prevost, **Accurate numerical solutions for Drucker--Prager elastic-plastic models.** *Computer Methods in Applied Mechanics and Engineering*, 1986. 54(3): p. 259-277.
- [8] Krieg, R. and D. Krieg, **Accuracies of numerical solution methods for the elastic-perfectly plastic model.** *ASME, Transactions, Series J- Journal of Pressure Vessel Technology*, 1977. 99: p. 510-515
- [9] Nyssen, C., **An efficient and accurate iterative method, allowing large incremental steps, to solve elasto-plastic problems.** *Computers & Structures*, 1981. 13(1-3): p. 63-71
- [10] Kodama, N. and K. Komiya, **Model Experiment and Numerical Modeling of Dynamic Soil-Structure Interaction**, in *Materials with Complex Behavior*, A. Öchsner, L.F.M. Silva, and H. Altenbach, Editors. 2010, Springer Berlin Heidelberg. p. 269-276
- [11] ANSYS. *Fem Software*. 2006

## LANDSLIDE SUSCEPTIBILITY MAPS (LSM) - METHODOLOGY AND APPLICATION IN SPATIAL PLANNING

**Adnan Ibrahimović<sup>1</sup>, Kenan Mandžić<sup>2</sup>, Nedreta Kikanović<sup>3</sup>, Elvir Babajić<sup>4</sup>**

### **Abstract**

*Landslide Susceptibility Maps (LSM) display the spatial probability of landslide occurrences. They are created at various scales, primarily depending on the purpose and size of the studied area, as well as the scale and detail of available input data. This article presents a heuristic (experiential) approach to defining the methodology for creating LSM. The processing and analysis of input data, as well as the generation of the LSM, are conducted within a GIS environment. The successful development of an area, which includes the development of necessary infrastructure systems, relies on a well-designed spatial plan, taking into account the challenging circumstances of landslide occurrences. The identification of landslide susceptible areas using LSM forms the basis for rational land management, with an emphasis on safe and planned construction. The article presents the methodology of creating LSM, as well as the potential and benefits of using LSM as an essential basis for spatial planning.*

**Keywords:** LSM, LSM creation methodology, GIS, Spatial planning.

---

<sup>1</sup>Dr sc.-Dipl.ing., Professor, Faculty of Mining, Geology and Civil Engineering Tuzla, [adnan.ibrahimovic@untz.ba](mailto:adnan.ibrahimovic@untz.ba)

<sup>2</sup>Dr sc.-Dipl.ing Professor, Faculty of Mining, Geology and Civil Engineering Tuzla, [kenan.mandzic@untz.ba](mailto:kenan.mandzic@untz.ba)

<sup>3</sup> Dr sc.-Dipl.ing., Assistant Professor, Faculty of Mining, Geology and Civil Engineering Tuzla, [nedreta.kikanovic@untz.ba](mailto:nedreta.kikanovic@untz.ba)

<sup>4</sup> Dr sc.-Dipl.ing., Associate Professor, Faculty of Mining, Geology and Civil Engineering, Tuzla, [elvir.babajic@untz.ba](mailto:elvir.babajic@untz.ba)



## 1. INTRODUCTION

Landslides represent one of the most significant geological exogenous processes during which slopes are formed. The cause of these movements lies in the disturbed equilibrium conditions in the soil or rock mass of the slope. The mechanism of this gravitational movement, or sliding mechanism, is often complex, and the masses set in motion by this mechanism can range from small occurrences to those that represent natural disasters in terms of volume and consequences. Due to their detrimental effects, both in material terms and, especially, in terms of human loss, landslides impose limitations on the use of existing buildings or infrastructure facilities, as well as on the design and construction of new structures. This problem becomes even more significant as the demand for overall human living and working space development, as well as modern infrastructure facilities, increases. Addressing these needs requires the elimination of limiting circumstances, among which the presence of landslides on existing slopes or slopes planned for construction represents one of the most common and serious challenges [1].

There are many examples worldwide, including our close surroundings and our own country, where landslides, due to their characteristics and consequences, are classified as catastrophic. It is estimated that the damages caused by landslides exceed several billion dollars annually globally, and thousands of people lose their lives [1].

The territory of Bosnia and Herzegovina is considered an area significantly affected by landslide phenomena. Certain regions can be singled out for having an exceptional rate of landslide occurrences. For instance, the Tuzla Canton area is particularly sensitive to landslide occurrences during rainy periods, when up to a thousand landslides of various sizes and degrees of activity can be simultaneously activated. Their consequences mainly involve partial and complete destruction of residential buildings and communal infrastructure [1].

Social and economic development increases the demand for new infrastructure systems and the adaptation of existing ones, which presents various professionals with new engineering challenges. The adequacy, in terms of operational safety, of new infrastructure systems also requires systematic planning, implementation, and further development [2].

As one of the challenging circumstances in the process of infrastructure system planning, processes that lead to soil and rock mass loss are generally observed, with landslides being the most common phenomenon in this context [1]. Additionally, the impact of climate change cannot be overlooked, as it further complicates the situation through an increase in triggering events for landslides [2].

Considering the presented facts, there is a need for assessing terrain susceptibility to landslides, which would improve the quality of the planning process. This primarily applies to planning within the framework of developing spatial plans at various levels. The assessment of landslide susceptibility is interpreted through the creation of Landslide Susceptibility Maps (LSM), which should serve as the foundation for high-quality spatial planning and as a basis for further activities and the design of infrastructure systems [2]. In essence, identifying landslide-prone areas forms the basis for rational land management, with an emphasis on safe and planned construction of any infrastructure system [3].

Planning is a human and social activity designed to influence the environment with the aim of changing it in a way that enhances tendencies towards coherence

and cohesion whereas keeping tendencies towards disintegration and decay under control. In other words, planning is a process whose function is to reduce entropy and increase organization in the environment [4].

Spatial planning, as the cornerstone of overall social development, represents a complex, demanding, and sensitive multidisciplinary category. Understanding and monitoring the development of society within new economic and political frameworks, along with human needs as the fundamental driving force for development, as well as the interrelationships and obligations, constitute the most significant component and prerequisite for successful outcomes in urban and spatial planning as a consumable resource as a whole [4].

This highlights the importance and magnitude of the task of spatial planning in general. When specific spatial problems, such as terrain instability, are added to the equation, as yet another complex component, only then can the depth and breadth of urbanistic issues and spatial planning be fully appreciated [4].

## **2. LANDSLIDE SUSCEPTIBILITY MAPS (LSM)**

The first official application of landslide zoning dates back to the 1970s and was based on a qualitative approach, whereas quantitative approaches were developed in the late 1980s [6]. The main causes of landslides can be identified, and most of them can be mapped, allowing for the assessment of the degree of landslide hazard [2].

The assessment of the degree of landslide hazard starts with landslide zoning, which enables the creation of appropriate maps providing various relevant data about this phenomenon and its evaluation. Based on landslide zoning and the data obtained through this process, they are interpreted into four fundamental types of maps:

- Landslide cadaster - record of past landslide events on the terrain;
- Landslide susceptibility map - spatially defined areas of different degrees of susceptibility to landslides;
- Landslide hazard map - maps that spatially define specific locations and conditions under which the landslide phenomenon can occur, with an assessment of the probability of that event;
- Landslide risk maps - maps that determine the qualitative and quantitative consequences (damages and losses) of potential landslide occurrences [2], [5], [6], [7].

Many landslides are located in densely populated areas, directly endangering people and property. Considering the high risks in such circumstances, the goal is to identify and classify high-risk landslide susceptible areas, which requires the creation of Landslide Susceptibility Maps (LSM). LSM are recognized as a priority in risk management and prevention of landslides. LSM represent the spatial probability of landslide occurrences by defining zones of equal terrain susceptibility to landslides and ranking them into classes. They are created at various scales, depending on the purpose and size of the studied area, as well as the scale and detail of available input data. In areas where landslides may occur, creating LSM is an essential step in defining the suitability of the terrain for construction and should be an integral part of the thematic information on the geological characteristics of the area. Identifying

landslide susceptible areas is the foundation of rational land management, with an emphasis on safe and planned construction.

Depending on the scale of creating LSM, the following approaches are used:

- Heuristic (empirical) approach, which allows the assessment of landslide susceptibility without using a landslide register,
- Scholastic (scientific) approach, which quantitatively defines the influence of parameters, as indicators of terrain characteristics, on the probability of landslide occurrence in space.

When it comes to LSM at a scale of 1:100000, the heuristic approach is considered optimal. Adequately zoning the terrain can assess the degree of susceptibility to landslides, which is the first step towards the ultimate goal - determining high hazard zones and defining risks over a large area. This enables planning to reduce the level of vulnerability of people and property due to landslide occurrences. Therefore, it can be said that LSM are just the first, but essential step in systematic landslide hazard and risk management [2], [4], [8].

### **2.1. Methodological foundations**

Existing methods for creating LSM at a small scale involve analyzing various input data, but they are often reduced to three basic sets of data in the form of factual maps. These are: engineering geology factors (lithological characteristics of the area), geomorphological factors (terrain slope), and land cover/land use [2], [9].

It is important to note that with a change in scale (larger scale), other influential factors can be added depending on the type of material (rock or soil), its characteristics, etc. In fact, in larger scales, these and other influential factors are significant and must not be overlooked. For example, in rock material, influential factors may include: rock type by genesis, discontinuity and fracturing of rock masses, weathering and alteration of rock material, all of which affect the potential for and mechanisms of rock mass loss from slopes and cliffs formed in that material. When it comes to soil, factors such as: the thickness of the genetic cover, mineral and granulometric composition of the soil, physical–mechanical characteristics of the soil, the influence of moisture changes on physical–mechanical characteristics, permeability, etc., can be taken into consideration.

After defining the influential factors, the use of GIS technology enables the implementation of multiple iterative processes, leading to relevant conclusions for creating LSM. The basic steps in creating LSM at a small scale (1:100000) can be defined as follows:

1. The creation of a reclassified terrain slope map is done from a digital elevation model (DEM) obtained based on a topographic map with a scale of 1:25000, and the grid cell size of 20x20 meters.
2. The creation of a reclassified map of engineering–geological units is based on basic geological maps at a scale of 1:100000, used to define engineering–geological units, which are separated based on engineering–geological characteristics.
3. The creation of a reclassified land cover map is based on the land cover map using the European database on biophysical land use, CORINE Land Cover (CLC), made according to CORINE standards, defining an output scale of 1:100000, a minimum mapping area of 25 acres, and a minimum polygon width of 100 meters. The CLC nomenclature includes

5 classes at level 1, 15 classes at level 2, and 44 classes at level 3 of land use. For the creation of LSM, the 3rd level of the CLC nomenclature was used.

4. Overlapping reclassified factor maps - all the mentioned factors are classified, meaning they are grouped based on similar characteristics. Each of these classes is assigned a corresponding number of points that quantify their influence on landslide occurrence. The highest number of points is assigned to classes representing the most unfavorable characteristics regarding landslide susceptibility, whereas the lowest number of points is assigned to classes representing the most favorable characteristics. The point range for all factors is between 0 - 40. The impact of each individual factor, in terms of landslide susceptibility, is defined through weighting factors. It has been found that terrain slope angle contributes the most to landslide susceptibility, followed by lithological characteristics defined through engineering–geological units, whereas land cover has a minor contribution to landslide occurrence [2], [3].

For the heuristic approach to creating LSM, it is necessary to analyze the influence of slope angle, engineering–geological characteristics, and land cover separately for each area, as the primary influence of one of these parameters may vary. For example, for the area of Žepče Municipality, the weighting factors were 0.5:0.4:0.1=slope angle: engineering–geological units: land cover, whereas for Brčko District, Bosnia and Herzegovina, they were 0.3:0.6:0.1=slope angle: engineering–geological units: land cover, as Brčko District is mostly a flat area with smaller slopes, where engineering–geological characteristics have a greater influence.

Table 1. shows the terrain classification based on its slope angle, divided into four classes for well and poorly consolidated rocks, and it pertains to the area of Prozor-Rama Municipality. Poorly consolidated rocks are represented by gray fields in the table.

Table 1. Classification of terrain slope and the number of points assigned to each class [3]

Class	Slope angle [°]	Area [km <sup>2</sup> ]	Number of Points
1	0-0.1	15.84	0
2	0.1-25	103.58	10
3	0.1-30	268.23	10
4	25-30	23.20	20
5	30-35	15.82	30
6	30-44	50.66	20
7	35-90	11.70	40
8	44-60	3.51	30
9	60-90	0.50	40

Unfavorable slopes, which are assigned a range of 30 to 40 points in poorly consolidated rocks, include classes 5 and 7. In well-consolidated rocks, these are classes 8 and 9. Based on the table, the total area of terrain covered by slopes with these angles can be determined, and it amounts to 6.4% for Prozor-Rama Municipality.

Furthermore, engineering–geological units are defined based on separated members of the basic geological map. The total number of lithological members (34 lithological members for the broader area) after the analyses has been classified into 8 engineering–geological units. Unfavorable terrains regarding landslide susceptibility are classes:

- Changes in solid and soft rocks, with a score of 30 points,
- Clayey rocks, coarse-grained, unconsolidated, with a score of 35 points,
- Weakly metamorphic rocks, clayey rocks, coarse-grained, poorly consolidated, with a score of 40 points [3].

The initial land cover classes are based on 44 classes at level 3, which are reclassified into 5 classes. The number of points for each CLC class is given in Table 2.

Table 2. Areas of CLC classes and their points for Prozor-Rama Municipality [3]

Class	Area [km <sup>2</sup> ]	Points
1	15.84	0
2	10.28	10
3	288.93	20
4	41.78	30
5	124.90	40






The graphical part of LSM consists of:

- Base map - LSM at a scale of 1:100000 with a legend,
- Auxiliary maps - three factor-classified input parameter maps at a scale of 1:350000, including: terrain slope map, engineering–geological units map, and land cover map,
- Overview map of Bosnia and Herzegovina at a scale of 1:2000000, with the location of the municipality for which the landslide susceptibility map was created marked.

Figure 1 shows the LSM for Žepče Municipality along with its auxiliary maps.

The total number of points for each 20x20 m grid cell, obtained in the described manner, represents the relative landslide susceptibility of the terrain. However, such representation is too complex for the defined scale, so for the final representation of LSM at a scale of 1:100000, five classes are defined based on point ranges, as shown in Table 3.

Table 3. Classes of landslide susceptibility with corresponding colors on LSM

Class	Landslide susceptibility	Number of Points	Corresponding color on the map
0	Water surfaces	0	
1	Low	1-80	
2	Medium	81-100	
3	High	101-120	
4	Very high	>120	

The susceptibility classes are determined qualitatively with terms: low, medium, high, and very high susceptibility, which are represented on the LSM by

corresponding colors: green, yellow, orange, and red. The class of water surfaces is shown in blue, which is separated as unclassified.

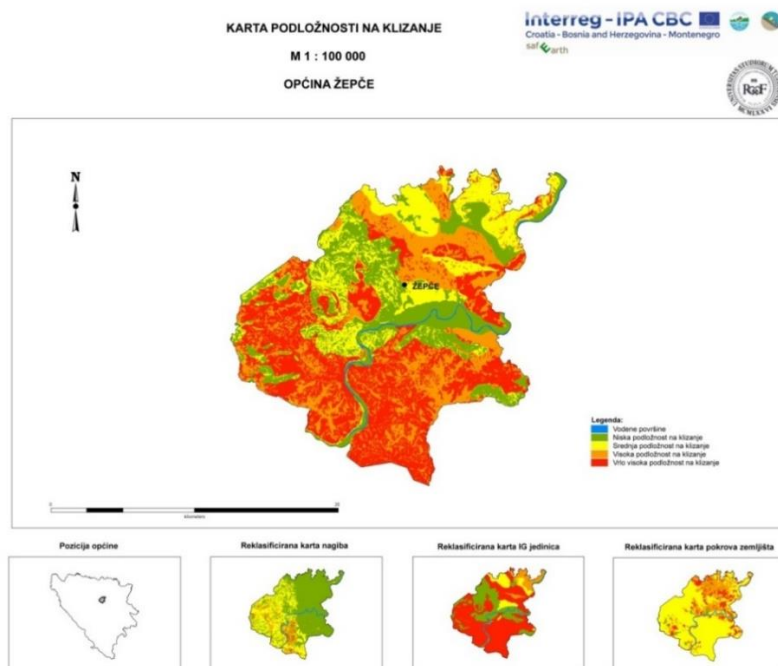


Figure 1. LSM for Žepče Municipality, Bosnia and Herzegovina, Scale 1:100000

### 3. APPLICATION OF LSM IN SPATIAL PLANNING

#### 3.1. Spatial planning concept in the Federation of Bosnia and Herzegovina and its disadvantages

Spatial planning, as the cornerstone of development in any area, represents a complex, demanding, and sensitive multidisciplinary category. The primary goal of every spatial development plan is to enable rational use and purposeful management of physical resources for the protection and enhancement of spatial quality, in order to achieve economic and social development and create conditions for humane and quality living for the population, as well as regional and urban development, in terms of spatial usage and opportunities for specific activities such as urbanization, industrialization, and construction of infrastructure facilities and systems [2], [4].

In space, that is, on the ground, there are micro and macro spatial units determined by social decisions regarding the type of spatial planning to be applied. There are lower-order and higher-order plans. Macro-spatial units encompass areas of municipalities, cities, cantons, states, or internationally defined spaces, and spatial plans are developed for them, which can be either general development plans or development plans for specific areas or areas with special purposes.

On the other hand, spatial planning in micro-spatial units is carried out through urban (master) plans, zoning plans, and urban design projects, covering areas of cities, settlements, parts of settlements, or land complexes for specific purposes [10].

Spatial planning, as a higher-order plan, is carried out in two phases:

- Phase I - preparation of the Spatial Framework with a proposed spatial development concept,
- Phase II - preparation of the Spatial Plan as the final document (preliminary draft, draft, and proposal) [2], [7],[10].

Within the Spatial Framework, the state of space is monitored through the structure of thematic layers, each of which has its own responsible entity that ensures the accuracy and credibility of data within that thematic area (14 thematic areas).

Given that all structures and systems are built on or in the ground/rock, the behavior of slopes during construction is one of the more important input indicators for construction land analysis in the spatial planning process. Therefore, in the spatial planning process, the thematic areas of "Natural Resources with Qualitative and Quantitative Characteristics" and "Areas at Risk of Consequences from Natural and Human-Induced Disasters" are highly significant. These two thematic areas require an analysis of geological characteristics of the terrain, such as basic morphological relief features, litho-stratigraphic composition of the terrain, structural-tectonic composition of the terrain, hydrogeological and hydrographic characteristics, engineering–geological characteristics, and seismic characteristics of the terrain. Past experiences of spatial planners in these thematic areas indicate a lack of adequate and high-quality data as input for the overall spatial analysis, which makes decision-making challenging for planners when determining land use and usage conditions [2], [4].

The study "Natural Conditions and Resources" is a document that should be prepared immediately before the commencement of spatial planning, as its content serves as a basis not only for the development of the plan, but also for other specialized studies. Often, its preparation is left out, and the completed studies have deficiencies due to the inadequate treatment of spatial definition of natural geotechnical risks. Usually, only a general overview of existing available geological, engineering–geological, hydrogeological, seismic, and other maps is provided without the necessary analysis of the interrelationships and overlaps of these parameters. Consequently, planners do not obtain high-quality and useful data in this field, which is essential for analyzing the current state within the proposed spatial development concept.

By defining a clear methodology for creating LSM and incorporating them into legal regulations, the work of the authors of the "Natural Conditions and Resources" study, as well as spatial planners, would be much easier. This would result in spatial plans with significantly reduced influence of landslides as unfavorable processes.

### **3.2. LSM as a mandatory criterion in the analysis of spatial suitability for urbanization**

The process of spatial planning and its associated decision-making processes inherently involve multiple objectives, multiple social interests, and preferences. Such complexity requires a systematic approach in decision-making processes to reconcile the ambiguity and multidimensionality of the problem under consideration and to increase the rationality, clarity, and acceptability of the decisions made. In general, two types of information can be associated with decision-making processes

in spatial planning: geographical information and information about decision-makers' preferences.

The application of Geographic Information Systems (GIS) is widely used in the inventory and mapping of spatial data, but the potential of GIS for planning and decision-making cannot be fully utilized due to its limited ability to represent judgments, arguments, and opinions of decision-makers. Integrating GIS and Multicriteria Decision-Making Methods is one way to overcome these limitations.[8]

One of the techniques of multicriteria decision-making in spatial planning processes, which allows integration with GIS tools, is known as the Analytic Hierarchy Process (AHP) spatial method (Fig 2). AHP is a mathematical method for analyzing complex decisions in spatial multicriteria analysis. Integrating AHP into GIS provides a mechanism for representing combinations of facts - in the form of spatial data - and values of expert judgments and helps overcome the limitations of conventional GIS tools. This integration provides a framework in which the advantages of GIS methodologies in data collection, processing, and analysis, as well as the capabilities of multicriteria analysis methods for aggregating geographic data and stakeholders' preferences, are optimally utilized in decision-making processes [4].

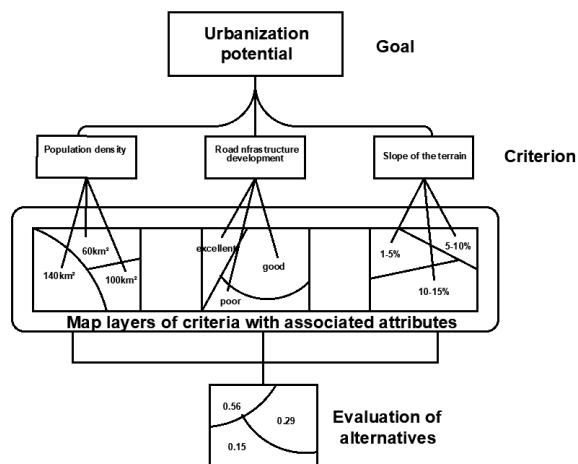


Figure 2. Hierarchy structure diagram for a hypothetical model of spatial suitability analysis for urbanization [4]

By incorporating LSM, as one of the mandatory criteria, which includes slope angle of the terrain, engineering–geological characteristics of the terrain, and land cover (as three basic criteria) in the analysis of terrain landslide susceptibility, we would obtain better, more accurate, and realistic data on the suitability of the area for urbanization, as shown in Figure 3.

Spatial planners are often faced with the challenge of defining areas that are outside the zones affected by landslide processes, in terms of safety and suitability for constructing certain structures. Typically, only basic geological maps at a scale of 1:100000 are used, and in rare cases, IG (engineering–geological) maps at a scale of 1:25000 are created to map existing landslides as a basis for developing a suitability map based on stability levels. In this way, the area is classified into one of three categories: stable, conditionally stable, and unstable terrain.



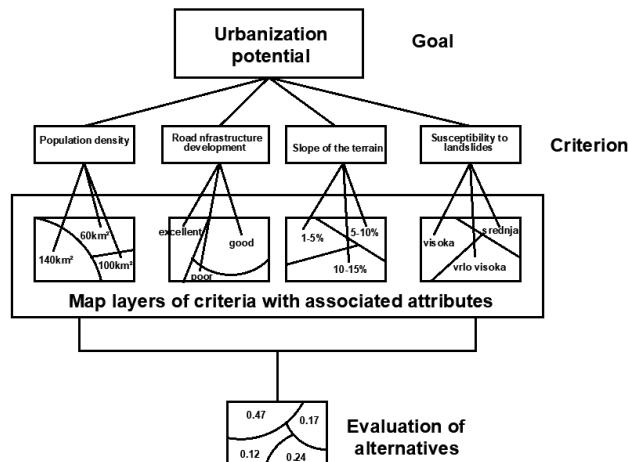


Figure 3. Hierarchy schema for a hypothetical model of suitability analysis for urbanization extended with LSM [4]

During spatial planning, areas outside zones affected by landslide processes are often considered stable due to the lack of adequate data, and construction of buildings or infrastructure systems is planned on them. By creating LSM, spatial planners obtain input data for the entire area covered by the spatial plan, including zones that are currently not affected by landslide processes but may have a certain spatial probability of landslide occurrence in the future, posing a risk to human lives and property. Analyzing landslide susceptibility at a regional level clearly defines areas with a high risk of landslides and enables directing detailed investigations at the local level, allowing spatial planners to adapt the type of structures to terrain conditions and plan additional research work.

#### 4. CONCLUSION

The Landslide Susceptibility Maps (LSM) do not predict the exact location of landslide occurrences. Also, areas with high susceptibility to landslides do not indicate the presence of active landslides, but rather represent areas with the highest probability of landslide occurrence. This serves as a warning in the process of spatial planning. Areas marked as having low probability of landslide occurrence do not mean that landslides cannot happen there. In simple terms, landslide susceptibility zones represent differences in the probability of landslides occurring in a particular area, but it is not possible to predict when a landslide will be activated.

For the interpretation of LSM, it is essential to understand the scale of the input data and the methodology used to create the LSM. In order to separate landslide susceptibility zones, reclassification of factor maps requires generalization. This means that specific locations within certain landslide susceptibility zones may have different susceptibility levels in reality compared to the estimated values.

The heuristic approach involves engineering experience, making it subjective and it is the main disadvantage of this approach. Considering the level of landslide susceptibility assessment provided by the presentation at a scale of 1:100000, as well as the ability to assess without using a landslide cadaster, the chosen approach justifies a high cost–benefit ratio for creating LSM. At this scale, LSM zone the

landslide susceptibility from the state level to the municipality/city level, and therefore, they cannot and should not be used to assess the stability of specific locations. Detailed engineering–geological and geotechnical investigations cannot be replaced by LSM on those locations.

The LSM at a scale of 1:100000 can serve as a basis for:

- Developing segments of cantonal and municipal/city spatial plans related to geotechnical characteristics of the area, terrain stability, spatial management, and defining special construction conditions;
- Identifying problematic areas concerning slope stability at the cantonal and municipal/city level;
- Selecting locations where detailed engineering–geological investigations are needed, and LSM needs to be created in a large scale (1:25000) and detailed scale (1:5000);
- Developing a disaster risk management strategy (as one of the bases);
- Planning regional development projects,
- Determining engineering constraints for large-scale projects;
- Informing local community structures and the broader public.

LSM allow spatial planners, when determining land use, especially for construction sites and infrastructure corridors, to assess the probability of landslides occurring in a particular area, starting from a general overview to a detailed spatial representation. This helps them make informed decisions regarding the use of that space. It must always be kept in mind that areas with high susceptibility do not necessarily mean the existence of landslides or the impossibility of construction in those areas. Instead, it assists spatial planners in directing their decisions concerning the type of land use and the manner of utilizing that space, whereas also stipulating through spatial planning documentation the necessity for detailed engineering–geological and geotechnical investigations as a precondition for construction in that area.

Assessments of terrain susceptibility to landslides should first be conducted at a regional level, and after analyzing the obtained results, specific areas at a local level where the risk of landslides is most pronounced should be identified. It is concluded that the development of LSM, with a clearly defined methodology, should be part of the legal regulations related to spatial planning at all levels of spatial plan development. This would provide clearer guidelines for experts in relevant fields to apply LSM in the spatial planning process. By using LSM in spatial planning, savings could be achieved through defining appropriate methods for constructing buildings and infrastructure systems for specific areas, enhancing the operational safety of structures and systems, and simultaneously reducing the risk of potential damage caused by landslide activation.

## ACKNOWLEDGMENTS

This article was made possible thanks to the implementation of the international project **safEarth** within the framework of the Interreg IPA-CBC, HR-BA-ME59, "Transnational advanced management of land use risk through landslide susceptibility maps design".

## REFERENCES

- [1] Ibrahimović, A., Mandžić, K.: **Sanacija klizišta**, *Mikroštampa*, Tuzla, 2013.
- [2] Mandžić, K., Kikanović, N., Ibrahimović, A.: **Significance of Landslides Susceptibility Maps in Creation of Spatial Planning Documentation**, *4th Regional Symposium on Landslides in the Adriatic-Balkan Region ReSyLAB*, Sarajevo, Bosnia and Herzegovina, 133-139, DOI: doi.org/10.35123/ReSyLAB\_2019\_22
- [3] Babajić, E., Kikanović, N., Mandžić, K., Ibrahimović, A., Hodžić, S.: **Methodology of Landslide Susceptibility Maps Creation in Small Scale on Municipality Prozor-Rama Example**, *Journal of Faculty of Mining, Geology and Civil Engineering Tuzla*, 6/2018, 47-55, 2018.
- [4] Kikanović, N., Mandžić, K., Ibrahimović, A.: **Poboljšanje izrade prostorno planske dokumentacije korištenjem karata podložnosti terena na klizanje**, *Druga Konferencija o urbanom planiranju i regionalnom razvoju, Udruženje inženjera konsultanata Bosne Hercegovine*, Sarajevo, Bosna i Hercegovina, 288-298, 2020.
- [5] Corominas, J., Van Westen, C.J., Frattini, P., Cascini, I., Malet, J.P., Fotopoulou, S., Catani, F., Van Den Eeckhaut, M., Ferlisi, S., Tofani, V., Hervas, J., Smith, J.T.: **Recommendation for the Quantitative Analysis of Landslide Risk**, *Bulletin of Engineering Geology and the Environment*, 73(2), 209-263, 2014.
- [6] Chacon, J., Irigaraj, C., Fernandez, T., Hamdouni, R.E.: **Engineering Geology Maps: Landslides and Geographical Information Systems**, *Bulletin of Engineering Geology and the Environment*, 65(4), 341-441, 2006.
- [7] Babajić, E., Kikanović, N., Mandžić, K., Ibrahimović, A., Hodžić, S.: **Radne upute za izradu karte podložnosti na klizanje**, *Project: Transnational Advanced Management of Land Use Risk Through Landslide Susceptibility Maps Design, Interreg IPA-CBC HR-BA-ME59, Rudarsko-geološko-građevinski fakultet Tuzla*, Tuzla, 2018.
- [8] Babajić, E., Kikanović, N., Mandžić, K., Ibrahimović, A., Hodžić, S.: **Tumači za kartu podložnosti na klizanje za općine Žepče, Prozor-Rama, grad Tuzla i Brčko distrikt BiH**, *Project: Transnational Advanced Management of Land Use Risk Through Landslide Susceptibility Maps Design, Interreg IPA-CBC HR-BA-ME59, Rudarsko-geološko-građevinski fakultet Tuzla*, Tuzla, 2018.
- [9] Lima, P., Steger, S., Glade, T., Tilch, N., Schwarz, L., Kocin, A.: **Landslide Susceptibility Mapping at National Scale: A First Attempt for Austria**, Mikos, M., Tiwari, B., Yin, Y., Sassa, K. (eds): *Advancing Culture of Living with Landslides, WLF 2017*, 943-951, 2017.
- [10] Bogunović, S.: **Metodološke osnove za izradu prostornih planova**, *Institut za arhitekturu, urbanizam i prostorno planiranje Arhitektonskog fakulteta u Sarajevu*, Sarajevo, 1984.

# APPLICATION OF GIS IN A SYSTEM FOR PLANNING, MANAGEMENT, AND MAINTENANCE OF SEWER NETWORK

Nedreta Kikanović<sup>1</sup>, Elvir Ferhatbegović<sup>2</sup>

## Abstract

Sewer systems, as part of the infrastructure of a municipality or city, are often not prioritized when it comes to development plans and funding. The development of wastewater and stormwater drainage systems, expansion, or reconstruction of these systems often requires significant and costly work. However, these efforts are necessary to avoid issues arising from the expansion of residential and commercial areas, which introduce new volumes of wastewater that need to be effectively managed to ensure proper sanitation protection and prevent endangering the broader ecosystem.

While we recognize that the foundation of an efficient sewer system lies in quality records and management of system components, in the Federation of Bosnia and Herzegovina, there are still municipalities where infrastructure systems, including sewer systems, function without maps of underground installations and structures. This often leads to various problems when planning new systems or reconstructing existing ones. The Federal Geodetic Administration has developed regulations for the establishment and maintenance of a cadastre of utility infrastructure. The content of the utility infrastructure cadastre database (BPKKU), attribute specifications, and interrelationships of BPKKU objects are defined by the utility infrastructure cadastre data model. Over the next three years, all municipalities and cities in the Federation of Bosnia and Herzegovina are required to establish and maintain the utility infrastructure cadastre according to the regulations and data model.

This paper describes the application of geographic information systems for recording, managing sewer system objects, and analyzing them. It also presents software support for establishing and maintaining the utility infrastructure cadastre (BPKKU).

**Key words:** Utility Infrastructure Cadastre, Geographic Information Systems, Sewer network maintenance

□

---

<sup>1</sup>Dr sc.-Dipl.ing., Assistant Professor, Faculty of Mining, Geology, and Civil Engineering, Tuzla, [nedreta.kikanovic@untz.ba](mailto:nedreta.kikanovic@untz.ba)

<sup>2</sup>Dr sc.-Dipl.ing, Gauss d.o.o, Tuzla, [Elvir.Ferhatbegovic@gauss.ba](mailto:Elvir.Ferhatbegovic@gauss.ba)

## 1. INTRODUCTION

In the Federation of Bosnia and Herzegovina, there are still municipalities where infrastructure systems, including sewer systems, operate without underground installation maps. This often leads to various issues when planning new systems or reconstructing existing sewer networks.

Sewer networks are complex systems composed of numerous interconnected elements (varying pipe diameters and properties, reservoirs, pump stations, various valve types, etc.). Significant resources are required for their construction, operation, and maintenance. Establishing a functional wastewater drainage system from technical and economic perspectives necessitates defining all system elements and their roles in its functioning. Understanding all hydraulic parameters is crucial for planning and building new systems or expanding existing wastewater drainage systems. Insufficient knowledge of system elements, their functions, and hydraulic parameters can lead to problems in system usage, such as reduced system capacity, structural pipe damage, reversed flow directions, uncontrolled wastewater overflow during heavy rainfall, and more.

During times of rapid development, the traditional method of recording and managing wastewater drainage system components cannot meet the demands of modern and efficient systems. Hence, there's a need for implementing a Geographic Information System (GIS) for wastewater drainage system management. This system focuses on the spatial dimension of infrastructure and its components, linking them with appropriate characteristics and establishing topological connections. This structure enables the system to become functional, providing quick access to precise information about the shape and condition of each object.

Such a GIS also facilitates efficient management of object changes, holistic visualization of the entire system, and the execution of necessary analyses and scenarios. This approach empowers designers to efficiently and rationally plan new projects, expansions, or reconstructions of existing wastewater drainage systems.

To aid in the accelerated establishment of GIS for utility infrastructure, including wastewater drainage, the Federal Geodetic Administration has developed regulations for creating and maintaining a cadastre of utility infrastructure. The content of the utility infrastructure cadastre database (BPKKU), attribute specifications, and interrelationships of BPKKU objects are defined by the utility infrastructure cadastre data model.

## 2. WASTEWATER DRAINAGE SYSTEM

The planning and construction of a wastewater drainage system are based on designing and building structures that facilitate efficient wastewater drainage. The components of the wastewater drainage system encompass all facilities designed for the collection, conveyance, and treatment of wastewater.

The fundamental components of the system include: manholes, inspection chambers, overflows, pumping stations, outlets, pressure pipelines, open and closed channels, wastewater treatment devices, and all other system structures. Each of these entities has its spatial, functional, and content-related attributes, and they are interconnected, collectively enabling the system to fulfill its primary function [1].

## 2.1. Maintenance of wastewater system

Effective maintenance of the sewer system is a fundamental prerequisite for rational management and environmental protection. The prerequisites for proper maintenance and operation of the sewer system, or sewer system management, include:

- thorough understanding of the system and its characteristics;
- sufficient number of qualified personnel;
- good organization; and
- adequate financial resources.

Without a maintenance plan for the sewer system, which requires an understanding of the system's characteristics (network registry), organized and efficient system maintenance cannot be carried out. This includes the inability to plan the necessary material, financial resources, and personnel. As sewer systems are unique to each settlement, a tailored approach to monitoring and maintaining each system is necessary. The organization responsible for managing the sewer system must develop a plan for regular inspection and maintenance of the sewer system. Maintaining and managing the sewer system today, and especially in the future, will become increasingly challenging and complex. The primary drivers behind this are the growing demands related to environmental protection and the increasingly intricate conditions of collecting and draining water from urban areas.

We differentiate between two types of maintenance:

Regular maintenance, which includes periodic condition assessment, occasional cleaning of channels, stormwater grates, and structures, routine repairs (system malfunction resolution), and the renovation of old and deteriorated channels.

- Incident-based maintenance involves interventions related to pipe bursts, excessive loads, water level fluctuations causing sewage to discharge into the soil or groundwater into the channels.

Since repairing sewer collectors is a complex and costly task, a detailed problem analysis and repair plan are essential. The steps that can be taken to make an appropriate decision are illustrated in the diagram 1. [2].

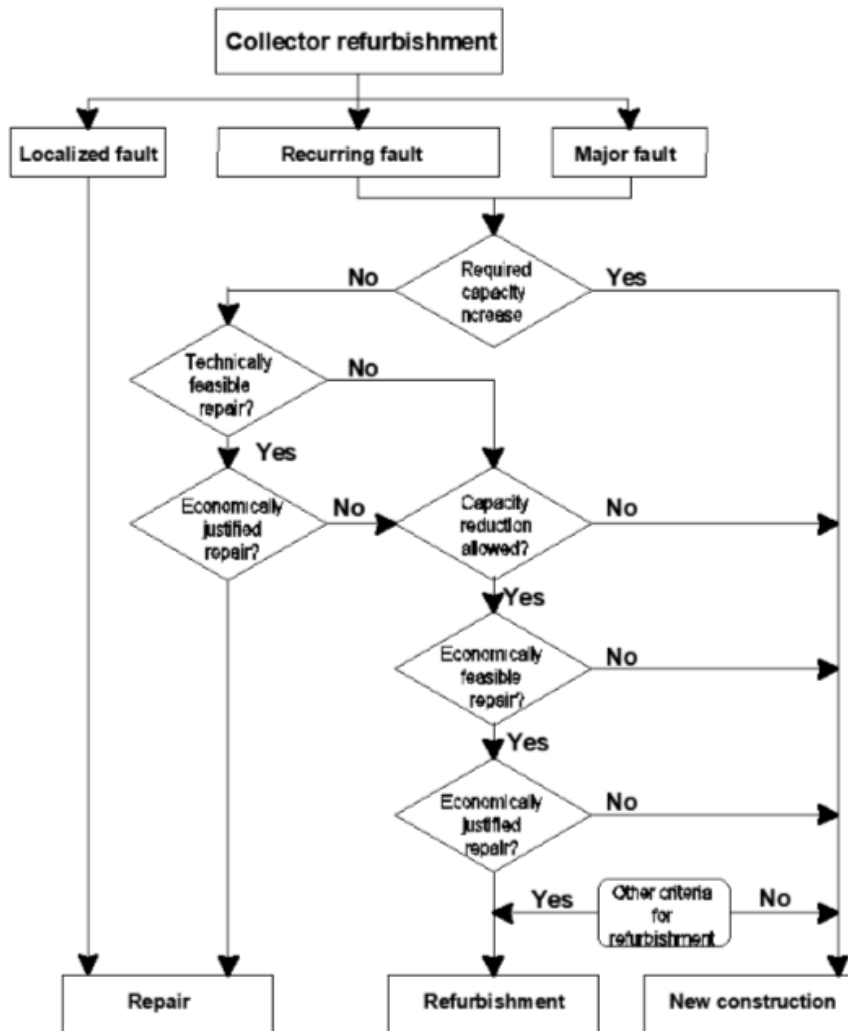


Diagram 1. Making Process for implementing measures to rectify faults in sewer collectors [3]

## 2.2. Management of wastewater system

Taking into account the spatial characteristics of the area from which wastewater collection and drainage occur, the technical and technological design of the sewer system should be characterized by the shortest drainage path for favorable economic effects. This involves achieving the shortest possible length of the collector, minimizing property ownership issues for land, minimizing pumping heights that should be avoided whenever possible and in field conditions, as well as ensuring the shortest time for wastewater to be removed from the source, resulting in positive ecological, sanitary, and operational effects. This approach aims to minimize the retention of wastewater in the collectors.

From a technical and technological perspective, a sewer system entails the construction of a more or less complex array of structures and channels (Figure 1.), commonly referred to as sewerage or a sewer system in practical terms [2], [3].

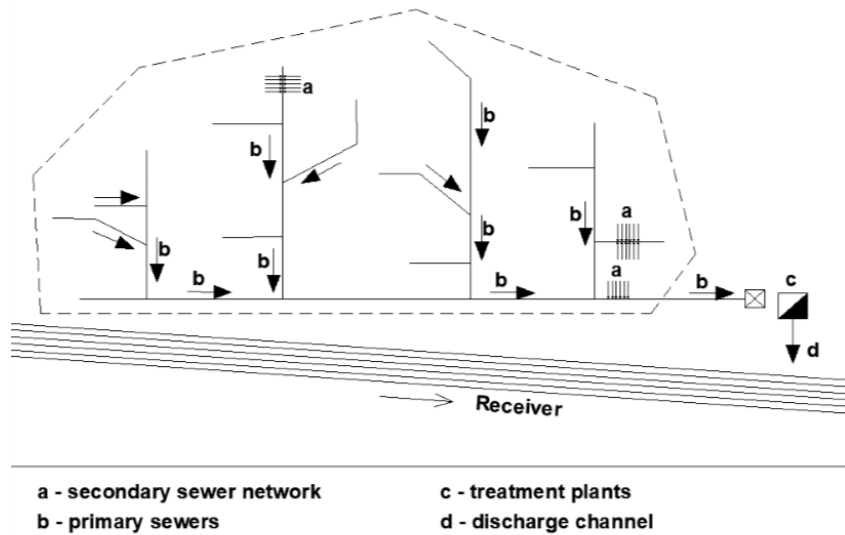


Figure 1. Basic Elements of the Sewer Technological System

However, the wastewater management system in populated areas is a much broader system that consists of:

- Management Unit, responsible for overseeing the enterprise;
- Technical-Technological Department, handling all technical activities related to construction, maintenance, and operation;
- Planning Department, creating short-term and long-term plans and monitoring their implementation;
- Administrative Department, organizing and ensuring the company's compliance with the law and its conducted activities;
- Financial Department, managing all financial transactions (collecting funds and payments);
- Advisory Department, usually external to the company, assisting the management team in decision-making;
- Supervisory Unit, overseeing the operations of the company's management unit.

For efficient management of urban sewage systems and optimal planning and investment in constructing new segments, it's essential to have knowledge and measurement of its fundamental parameters:

- Flow and water quality in the collectors at selected profiles,
- Levels in the pumping stations of the sewer pumping stations,
- Rainfall intensity in the drainage areas of characteristic measurement profiles, utilizing dedicated measurement stations and statistical data analysis [4].

In developed countries, there has been a longstanding emphasis on regular measurements of fundamental parameters, a practice that is not yet prevalent in our region. Therefore, it is essential to make an effort to bring about change and highlight the significance of measurements. Of course, this requires additional, substantial financial investments to procure modern and dependable measurement equipment.



### **3. DATA MODEL OF THE CADASTRE OF UTILITY INFRASTRUCTURE PRESCRIBED BY THE FEDERAL GEODETIC ADMINISTRATION**

The Federal Geodetic Administration has developed regulations for the creation and maintenance of the Cadastre of Utility Infrastructure. The content of the Cadastre of Utility Infrastructure Database (BPKKU), the specification of attributes, and the mutual relationships of objects within the BPKKU are prescribed by the Data Model of the Cadastre of Utility Infrastructure. According to this, all municipalities and cities within the Federation of Bosnia and Herzegovina are required to establish and maintain the Cadastre of Utility Infrastructure in accordance with the regulations and data model within the next 3 years.

This regulation specifies the content, creation, maintenance, distribution, and storage of data related to the Cadastre of Utility Infrastructure and its users in the Federation of Bosnia and Herzegovina. The term "utility infrastructure," as defined by this regulation, includes: water supply network, sewage network, power supply network, electric power lines for traffic needs, district heating and steam networks, telecommunication network, gas supply network, oil pipeline network, drainage network, and associated facilities (tunnels, shelters, underground passages and garages, basements, etc.) that serve as utility infrastructure. Depending on their type, utility infrastructures can be underground or above ground.

The responsibility for creating the cadastre lies with the city or municipal cadastral services, which are in charge of creating and maintaining the BPKKU as a comprehensive record of data about utility infrastructures. It is also the obligation of all utility organizations within a specific local government unit (LGU) to provide data to this comprehensive record in accordance with the regulations and data model prescribed by the Federal Geodetic Administration Sarajevo. Utility organizations, in addition to the above, may also maintain their own technical databases that can contain more details than those prescribed by the regulations and data model, as needed [5].

The main groups of processes executed over the Cadastre of Utility Infrastructure (BPKKU) are:

- Creation,
- Maintenance,
- Distribution and exchange,
- Storage, archiving, and data protection.

The mentioned processes over the Cadastre of Utility Infrastructure (BPKKU) are carried out according to technical standards and methods for recording details in line with the current legal and sublegal regulations, as well as the provisions of this Regulation. The content of BPKKU, attribute specifications, and mutual relationships of objects within BPKKU are prescribed by the Data Model of the Cadastre of Utility Infrastructure (Figure 2).

The content of BPKKU comprises:

- List of utility infrastructures,
- List of users of utility infrastructures,
- Plan of utility infrastructures,
- Collection of geodetic survey reports for utility infrastructures.

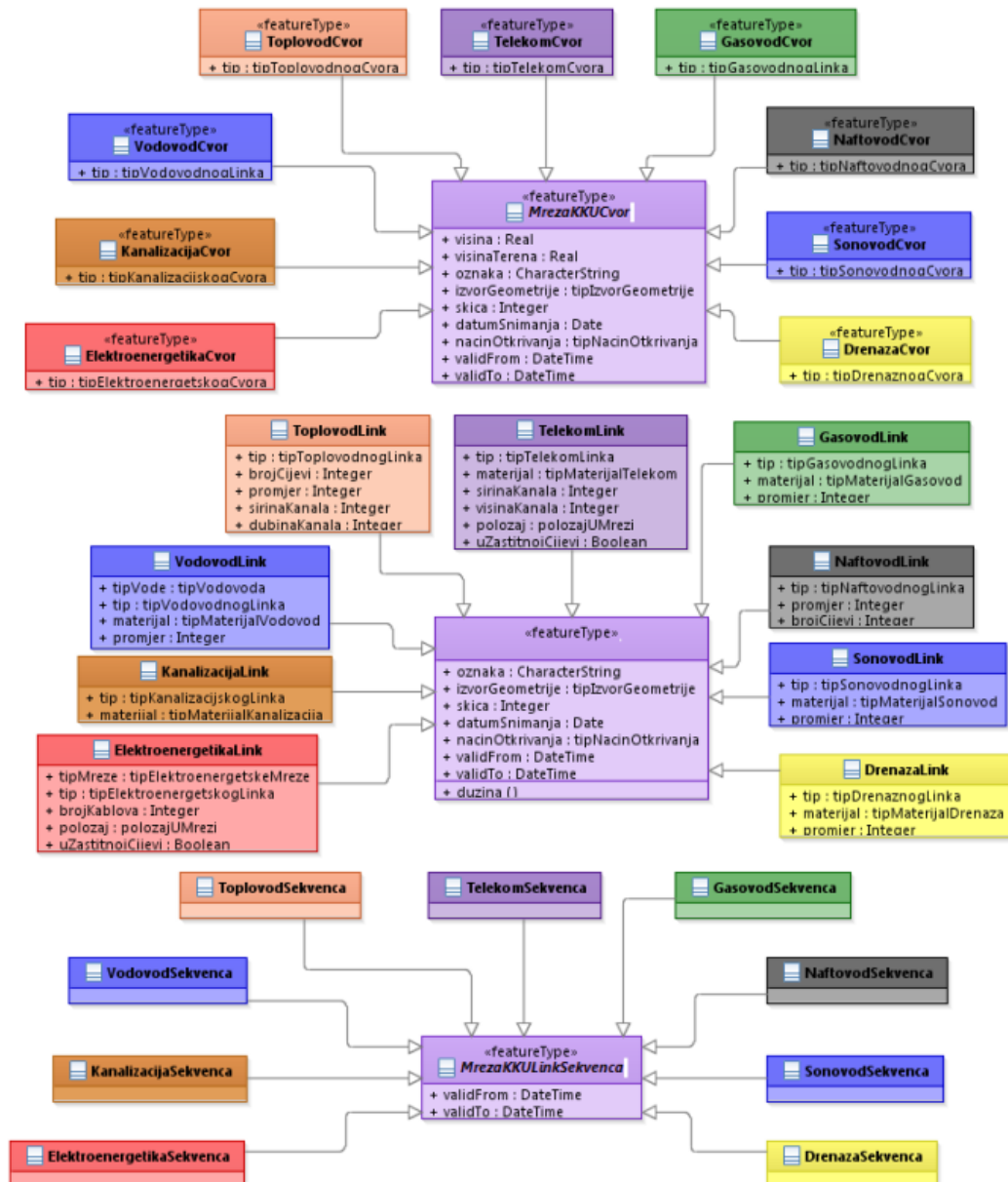


Figure 2. Data Model of the Cadastre of Utility Infrastructure [6]

#### 4. GEOGRAPHIC INFORMATION SYSTEM (GIS)

It's difficult to provide a single comprehensive definition of GIS. One of the definitions that emerged from practical experiences in GIS development is as follows:

"A Geographic Information System is, in a general sense, an integrated system composed of computer tools and user software designed to collect, organize, handle, analyze, model, and display spatial data with the aim of solving complex problems related to analysis and planning."

All the data used in GIS are schematized using a model of geographic data. Two contrasting approaches view space either as a set of entities describing their attributes and mapped using a coordinate system, or as a continuous field of variations without distinct boundaries. As these conceptual ideas are characterized by formalized models of geographic data, they can be divided into units that are registered and mapped. The primary approaches involve using a series of points, lines, and polygons, or fundamental cellular units to describe terrain and landscape characteristics. Embracing a specific model influences both the type of data that can be used to describe phenomena and the spatial analysis that can be undertaken.

**Entities:**

The most common perspective represents the formulation that space is filled with "objects" or entities. The first step involves defining and recognizing entities, such as houses, cables, rivers, or forests. The second step is formulating its attributes and defining its boundaries and location.

**Continuous Fields:**

In the approach involving continuous fields, the simplest conceptual model represents geographical space as continuous rectangular coordinates in two or three dimensions (or four if time is included).

From the perspective of analyzing sewerage systems, the entity-based model is more suitable [3].

Geographic Information Systems (GIS) for drainage systems belong to the topology of a network system, and accordingly, they are divided and defined by the basic objects of the drainage information system. The fundamental objects are categorized as: nodes, links, and polygons. Among the node objects, there are system components such as manholes, catch basins, pumping stations, outfalls, and more. Line objects include system components such as pressure pipes, open and closed channels, weirs, and more. Polygonal objects mainly refer to catchment areas, which provide crucial information about the quantity and temporal distribution of rainfall entering the drainage system [7].

For a rational approach to solving the majority of issues that surround us, GIS has become a standard, being significantly prevalent in contemporary solutions for municipal infrastructure challenges. With the advancement and development of sewage system management, GIS has become an invaluable tool due to its capability to provide an abundance of data about objects within the sewage network. GIS models allow municipal companies to better monitor and align with laws and regulations, providing easy and swift overviews and analyses of all potential problematic areas. This facilitates making informed decisions concerning the development and reconstruction of drainage systems [8].

#### **4.1. The establishment of a GIS for a sewage system**

The establishment of a Geographic Information System (GIS) for a sewage system involves the process of collecting, analyzing, organizing, and visualizing data about the sewage system using geographic information. GIS is used to create a digital model of the sewerage network, enabling better understanding, planning, and management of the sewage system.

The establishment of a Geographic Information System (GIS) for a sewage system involves several key steps:

- **Planning and Requirements Analysis:** Identify the specific needs and goals of implementing a GIS for the sewage system. Determine the types of data to be collected, analyzed, and managed, as well as the desired functionalities.
- **Data Collection:** Gather spatial data related to the sewage system, including locations of manholes, pipes, pumping stations, outfalls, drainage areas, and any other relevant infrastructure. This may involve surveys, satellite imagery, and existing maps.
- *Data Integration: Organize and integrate collected data into the GIS software. This involves converting data into a digital format and ensuring it's properly georeferenced.*
- *Database Design: Design a database structure that can efficiently store and manage the collected spatial data. This structure should allow for easy retrieval and manipulation of information.*
- *Data Entry: Input the spatial data into the GIS database. This includes adding attributes to each spatial feature to provide additional information.*
- *Data Analysis and Modeling: Utilize GIS tools to perform spatial analyses, such as flow modeling, hydraulic analysis, and identification of critical areas prone to flooding or overflow.*
- *Visualization: Create maps and visual representations of the sewage system's components, including pipes, manholes, pumping stations, and drainage areas.*
- *Decision Support: Use the GIS to make informed decisions about maintenance, repairs, upgrades, and expansion of the sewage system. This could involve identifying areas with frequent issues or planning for future development.*
- *User Training: Train personnel responsible for managing and utilizing the GIS system, ensuring they are proficient in data entry, analysis, and using GIS tools effectively.*
- *Implementation and Maintenance: Deploy the GIS system within the organization and continuously update and maintain the data as changes occur in the sewage system.*
- *Integration with Other Systems: Integrate the GIS with other relevant systems, such as asset management or work order systems, to enhance overall efficiency and decision-making.*

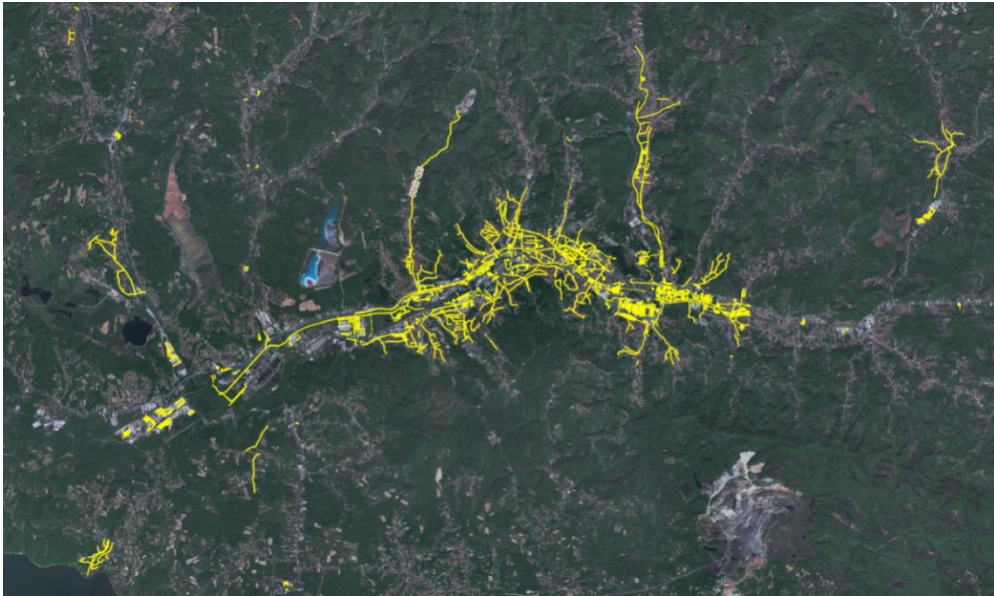
Forming a GIS for a sewage system involves collaboration among various stakeholders, including urban planners, engineers, GIS specialists, and local authorities, to ensure effective data management, analysis, and decision support for maintaining and improving the sewage infrastructure.

It should be emphasized that the positional and elevation information of the sewage network needs to be determined with a high degree of accuracy, and the system should be supplemented as needed by obtaining missing data through surveying or acquiring data from existing maps that contain the required information. The data processing itself should encompass a series of auxiliary tasks such as:

- *Establishing network topology,*
- *Verifying the network structure,*
- *Checking the entered data in associated tables,*

- *Conducting necessary analyses to indicate data accuracy or deficiencies,*
- *Creating working longitudinal profiles, and more.*

After reviewing and correcting errors that occurred during the establishment of the GIS for the sewage system, it is necessary to edit the formed network topology and carry out its editing. Figure 3. shows the existing sewage network in the city of Tuzla. A database of the cadastre of communal facilities has been established for the city of Tuzla, which also includes the maintenance of the sewage network. This well-established database serves as a solid foundation for all necessary analyses, planning, and management of both the sewage network and the entire city infrastructure.



*Figure 3. Sewage network in the area of Tuzla city*

To establish a hydraulic model, it is necessary to review the available data regarding the elevations of manhole covers and sewer network levels, and if needed, supplement the database using one of the surveying methods. In the existing database of the cadastral registry of communal facilities for the city of Tuzla, elevation data for a portion of the sewage network is already input, as shown in Figure 4.

All objects within the GIS of the sewage system should be processed in a manner that enables obtaining the required information related to these objects. The level and method of processing should be aligned with the requirements of further practical use of the GIS as a fundamental technical basis for the maintenance and development of the sewage system.

From a well-established GIS database, thematic maps can be generated, providing a visual representation of necessary data in a tabular format, and various analyses essential for the effective functioning and maintenance of the sewage system can be conducted based on queries and requests.

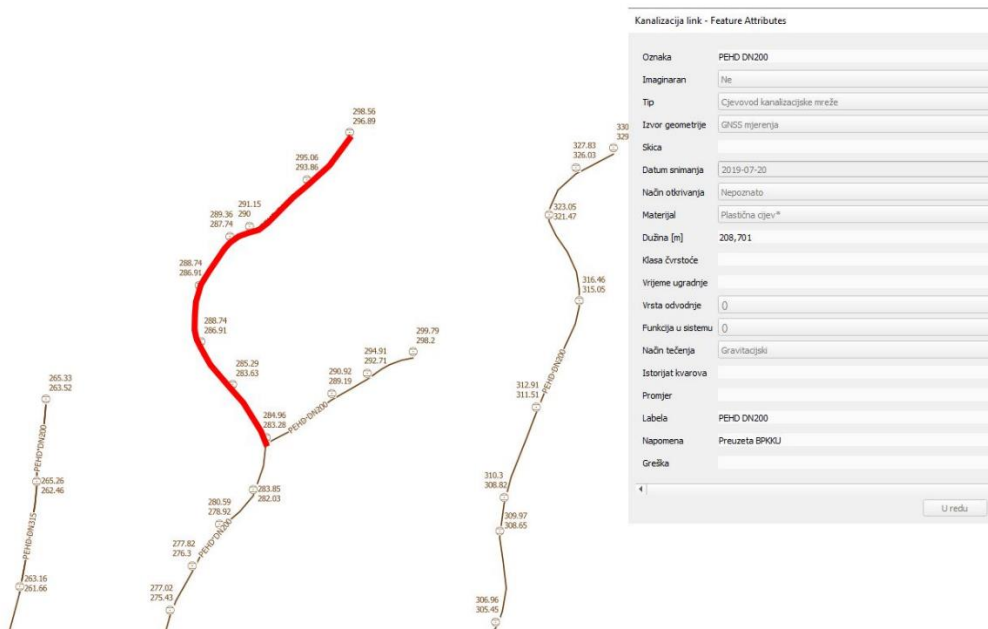


Figure4. Representation of attribute data for the ewage network

#### 4.2. Advantages of GIS in sewage system maintenance include

By visualizing data in GIS, a large amount of attribute data stored in computers can be displayed in a simple, pictorial, and user-friendly form. Inputting spatial data into the computer and linking it with attribute data allows for analysis, inference, and logical interpretation. In solving a problem, GIS can integrate perspectives from practically all disciplines relevant to that problem. Through GIS-based simulations of flow and management within the sewage system, a solid foundation is established for rational and sustainable system management [9].

In order to create an accurate maintenance plan for the sewage system, perform system inspections using cameras, and propose measures for addressing critical points, it is necessary to conduct on-site assessments of the actual condition of the sewage system, gather all information about its components, and store this data in a database.

Through the implementation of a GIS for the sewage system, the management and maintenance of the system become more efficient as they rely on precise, up-to-date, and spatially linked data. GIS also aids in reducing the risk of failures, enhancing operational efficiency, and facilitating better planning for future development projects [7].

### 5. CONCLUSION

A Geographic Information System (GIS) represents an exceptionally powerful tool in the planning, management, and maintenance of sewage systems. The integration of spatial and attribute data enables precise analysis, visualization, and informed decision-making related to sewage infrastructure. GIS facilitates the identification of issues, intervention planning, system monitoring, and optimal resource utilization.

Through GIS, information about the locations and characteristics of sewage components is efficiently managed, easing the tracking of conditions and swift responses to potential problems. Additionally, GIS enables a better understanding of intricate relationships within the system, including the identification of potential critical points demanding attention.

With the aid of GIS, the management of sewage system maintenance becomes more transparent and efficient. This technology empowers multi-level data analysis, streamlines collaboration among different sectors, and enables improved planning for future developmental steps.

Essentially, GIS serves as a pivotal tool for modernizing and optimizing the management of sewage systems, providing a foundation for sustainable, secure, and environmentally responsible control over these vital infrastructural components. By forming a GIS for the entire established sewage system, a simulation model for flow and management can be established as a key element of rational and sustainable system management.

By creating a list of relevant criteria, it becomes possible to conduct multi-criteria prioritization for expansion and reconstruction of the sewage network. These analyses allow for the selection of the appropriate type of wastewater treatment devices, along with the corresponding facilities and equipment, and the level of treatment, from a technical standpoint.

## REFERENCES

- [1] Halapija H., Piskor D., Radeljić, I.: **Prostorni informacijski sustavi odvodnje – sinergija geodezije, građevine i informatike**, *Zbornik radova I. simpozija ovlaštenih inženjera geodezije: Hrvatska geodezija – izazovi struke u 21. Stoljeću*, 2008.
- [2] Margeta, J.: **Kanalizacija naselja: odvodnja i zbrinjavanje otpadnih i oborinskih voda**, *Građevinsko-arhitektonski fakultet Sveučilišta u Splitu*, Split, 2009.
- [3] Kikanović N., **Kanalizacioni sistemi kao faktor urbanog planiranja područja Tuzle, doktorska disertacija**, *Rudarsko-geološko-građevinskifakultet, Univerzitet u Tuzli*, 2015.
- [4] Cvjetković M., **Vodovod i kanalizacija upravljanje**, Beograd, 2014.
- [5] **Pravilnik o izradi i održavanju katastra komunalnih uređaja**, *Službene novine Federacije Bosne I Hercegovine*, 25.6.2021.
- [6] **Model podataka katastra komunalnih uređaja FBiH, Verzija: 1.3; 2013.**, *FGU Sarajevo*
- [7] **Model podataka katastra komunalnih uređaja FBiH, Verzija: 1.3; 2013.**, *FGU Sarajevo*
- [8] Haines, D.: **GIS Improves Stormwater Management**, Government Engineering, September-October, 2006.
- [9] [http://www.geomodeling.hr/prosto.r.ni\\_informacijski\\_sustavi.html](http://www.geomodeling.hr/prosto.r.ni_informacijski_sustavi.html) (7.6.2012.)

# THE IMPORTANCE OF THE NEXUS GOVERNANCE FOR ACHIEVING SDGS

Tamara Rađenović<sup>1</sup>, Dejan Vasović<sup>2</sup>, Žarko Vranjanac<sup>3</sup>, Snežana Živković<sup>4</sup>, Slobodan Milutinović<sup>5</sup>

## Abstract

*Sustainable Development Goals (SDGs) were established as a universal call for action to build a global partnership for sustainable development to improve human lives and protect the environment. Today there are 17 SDGs which are divided into 169 targets comprising 231 unique indicators intending to achieve the targets. As the interconnected nature of these goals becomes more evident, the importance of the Nexus governance approach in facilitating their achievement cannot be overstated. The Nexus approach recognizes that various sectors, especially water, energy, and food, are deeply intertwined, and consequently that actions in one area often have repercussions in others. Hence, it proposes a move away from isolated decision-making towards a more integrated, holistic approach, keeping in mind the multifaceted interdependencies between these sectors. As this approach seeks to address global challenges like climate change, population growth, and resource scarcity in a more sustainable and efficient manner, the aim of this paper is to investigate the role of Nexus governance in achieving SDGs. The findings will provide the basis for a better understanding and possible implementation of the Nexus approach in decision-making for sustainable resource management.*

**Key words:** Nexus, governance, sustainable development, SDGs

---

<sup>1</sup> PhD, Assistant Professor, Faculty of Occupational Safety, University of Niš, tamara.radjenovic@znrfak.ni.ac.rs

<sup>2</sup> PhD, Associate Professor, Faculty of Occupational Safety, University of Niš, dejan.vasovic@znrfak.ni.ac.rs

<sup>3</sup> MSc, Research Assistant, Innovation Center, University of Niš, zarevranjanac@gmail.com

<sup>4</sup> PhD, Professor, Faculty of Occupational Safety, University of Niš, snezana.zivkovic@znrfak.ni.ac.rs

<sup>5</sup> PhD, Professor, Faculty of Occupational Safety, University of Niš, slobodan.milutinovic@znrfak.ni.ac.rs



## 1. INTRODUCTION

In 2015, United Nations (UN) Member States adopted the 2030 Agenda for Sustainable Development [1], as a blueprint for peace and prosperity for people and the planet, calling for urgent action by all countries in global partnership [2]. At its core are the 17 SDGs, which are divided into 169 targets comprising 231 unique indicators, including the voices of over a million people from around the world through massive stakeholders' consultations that involved governments, companies, civil society organizations, and knowledge institutes [3]. They understand that addressing poverty and related deprivations requires simultaneous strategies to enhance health and education, decrease inequality, and boost economic growth – all should be paired with combating climate change and ensuring the preservation of our oceans and forests [2].

SDGs represent a most influential framework and global commitment to eradicate poverty, protect the environment, and ensure prosperity for all by 2030. Achieving these ambitious objectives demands a departure from traditional siloed approaches to more integrated and synergistic frameworks. Central to this shift is the Nexus approach, which recognizes the interlinkages between sectors such as water, energy, and food, known collectively as the Water-Energy-Food (WEF) Nexus [4]. This interconnectedness underpins the rationale for the Nexus governance framework – a model that promotes holistic management, policy coherence, and cross-sectoral collaboration.

The Nexus governance framework does not merely act as an innovative approach to resource management but serves as an essential tool in steering nations towards the actualization of SDGs [5]. Its emphasis on systems thinking, stakeholder engagement, and interdisciplinary collaboration ensures that strategies devised are not only robust but also resilient in the face of mounting global challenges. This paper delves into the significance of the Nexus governance framework in achieving SDGs, exploring its key principles and potential effects on global sustainable development pathways. Through a comprehensive analysis, the intention of the paper is to shed light on how integrating Nexus thinking into governance can catalyse transformative change and lead the world closer to its 2030 vision.

The paper is organized as follows: after the introduction, the assessment of SDGs' progress is introduced, followed by the rise of the nexus approach. Then the Nexus governance framework is presented followed by its role in advancing SDGs. Finally, the conclusion highlights the main findings and future recommendations.

## 2. ASSESSING THE SDGS' PROGRESS

Following the introduction of the SDGs in 2015 (Figure 1), the UN each year presents an annual SDG Progress report. This series of reports is established to track the progress towards the achievement of SDGs across countries. Figure 2 provides the progress assessment of the individual SDGs documented in the latest SDG Progress report for 2023 [7]. As can be viewed from the Figure, the situation is not so promising, as the main problem is certainly the lack of data, and then also, only a small per cent of the countries is on track or has met the targets, and this is only for a few SDGs. According to the provided insights the more concerning picture

is the SDG progress at the midpoint, according to which only 15% are on track, 48% are moderately or severely off track, and 37% report stagnation or regression [7].



Figure 1. Sustainable Development Goals (SDGs), source: [6]

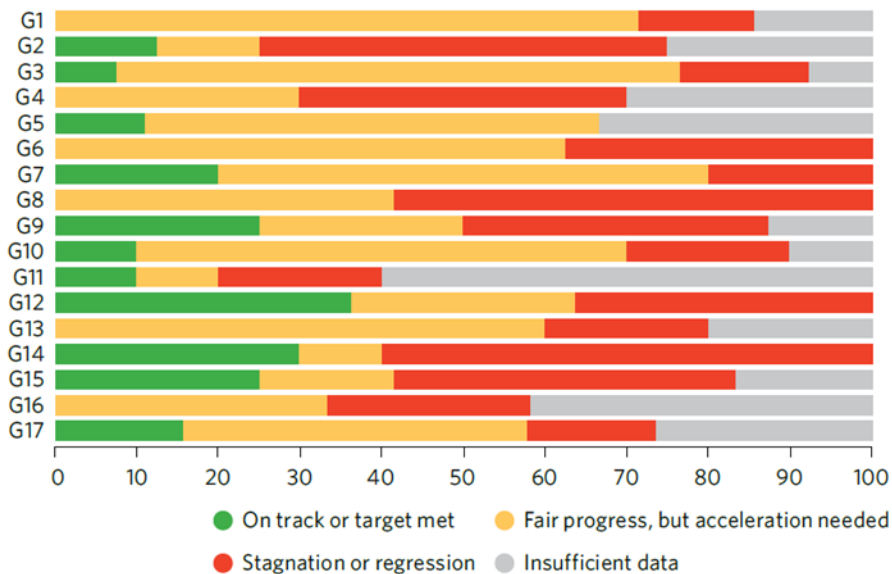


Figure 2. Progress assessment for the 17 SDGs based on assessed targets, source: [7]

The SDGs report highlights the following trends across goals [7]:

1. Notwithstanding the fact that countries have increased government spending on essential services (education, health and social protection) from 47% in 2015 to 53% in 2021, if current trends continue, by 2030 575 million people will still be living in extreme poverty (less than \$2.15 per person per day at the 2017 purchasing power parity), and only one-third of countries will have halved their national poverty levels.
2. More than 600 million people worldwide are projected to face hunger in 2030, 1 in 3 people struggle with moderate to severe food insecurity, while high food prices continue to plague many nations and malnutrition

- persists worldwide, jeopardizing children's well-being and future development.
3. Some progress has been achieved in improving global health in recent years, for example, 146 out of 200 countries or areas have already met or are on track to meet the SDG target on under-5 mortality, but, insufficient progress has been made in other areas, such as on reducing maternal mortality and expanding universal health coverage.
  4. Despite slow progress world is falling far behind in achieving quality education, and without additional measures, only one in six countries will achieve the universal secondary school completion target by 2030, 84 million children and young people will be out of school, and 300 million students will lack the basic numeracy and literacy skills.
  5. The world is not on track to achieve gender equality by 2030 (only 15.4% out of goal 5 indicators are on track), and at the current rate, it will take 300 years to end child marriage, 286 years to close gaps in legal protection and remove discriminatory laws, and 140 years to achieve equal representation in leadership in the workplace.
  6. Safe drinking water, sanitation and hygiene are still out of reach for billions, i.e., in 2022, 2.2 billion people lacked safely managed drinking water and basic hand washing facilities, 3.5 billion people lacked safely managed sanitation, and 2.4 billion people lived in water-stressed countries. Hence, to meet 2030 targets the integrated water resource management implementation needs acceleration of 6 times for drinking water, 5 times for sanitation, and 3 times for hygiene.
  7. Although modern renewables power nearly 30% of electricity, 675 million people still live in the dark, international public financing for clean energy for developing countries continues to decline, and to reach the set targets energy efficiency improvement must more than double its pace.
  8. Global economic recovery continues on a slow trajectory (projected real GDP per capita growth rate at 1.4% in 2023 and 1.6% in 2024), with 2 billion workers in precarious informal jobs without social protection, and 1 in 4 young people not in education, employment or training.
  9. Global manufacturing growth slowed from 7.4% in 2021 to 3.3% in 2022 due to inflation, energy price shocks, supply disruptions and global economic deceleration, while medium-high and high-technology industries experienced strong growth in 2022. But, energy-related CO<sub>2</sub> emissions reached a record high of 36.8 billion metric tons in 2022.
  10. The pandemic has caused the largest rise in between-country inequality in three decades, whereas 1 in 6 people worldwide has experienced discrimination in some form, with women and people with disabilities disproportionately affected.
  11. Over half of the global population currently resides in urban areas, and this rate is projected to reach 70% by 2050. Approximately 1.1 billion people currently live in slums or slum-like conditions in cities, while 2 billion more are expected in the next 30 years. In 2022, only half of the world's urban population had convenient access to public transportation, while urban sprawl, air pollution and limited open public spaces persisted in cities.

12. High-income countries leave a larger environmental footprint compared to low-income countries, i.e., the material footprint per capita in high-income countries is 10 times higher compared to low-income countries (24:2.5 metric tons). On average each person wastes 120 kilograms of food per year. The trend towards sustainability reporting is on the rise, as the percentage tripled from 2016 to 2021.
13. The world will exceed 1.5°C by 2035 and face a 2.5°C warming by 2100, and hence deep, rapid and sustained greenhouse gas emission reductions by 43% by 2030 and to net zero by 2050 are needed. Besides, the rate of sea-level rise has doubled in the last decade, while highly vulnerable regions have experienced 15 times higher mortality rates from disasters compared to very low vulnerability regions in the period 2010-2020. However, the commitment of developed countries to mobilize \$100 billion in climate finance annually by 2020 to 2025 has not yet been met (in 2020 \$83.3 billion mostly in the form of loans to developing countries).
14. The ocean is in a state of emergency as increasing eutrophication (causing algal blooms and dead zones), acidification (30% higher than in the pre-industrial period), ocean warming and plastic pollution (17 million metric tons in 2021) worsen its health. Additionally, the alarming trend of overfishing persists, leading to the depletion of over one-third of global fish stocks.
15. Escalating trends of forest loss, land degradation and the extinction of species pose a severe threat to both the planet and people. Global forest coverage decreased from 31.9% to 31.2% in the period 2000-2020, where agricultural expansion is the direct driver of almost 90% of global deforestation. Between 2015 and 2019, at least 100 million hectares of healthy and productive land were degraded every year, affecting food and water security globally. The world is currently facing the largest species extinction event since the dinosaur age.
16. In 2022, there was reported a more than 50% increase in conflict-related civilian deaths, largely due to the war in Ukraine, 108.4 million people were forcibly displaced worldwide (an increase of 19 million compared with the end of 2021, and two and a half times the number of a decade ago. In 2021, the world experienced the highest number of intentional homicides in the past two decades (458,000).
17. Developing countries are grappling with an unprecedented rise in external debt levels following the COVID-19 pandemic (total external debt of low- and middle-income countries reached \$9 trillion in 2021), emphasizing the urgent need for debt relief and financial assistance. In 2022, net Official Development Assistance (ODA) flows by member countries of the Development Assistance Committee (DAC) reached \$206 billion (current price), marking an increase of 15.3% in real terms from 2021.

### **3. THE RISE OF THE NEXUS APPROACH**

The Nexus concept has been gradually evolving as a comprehensive approach that connects sectors and views interconnected resources without bias, aiming for sustainable resource management [5]. Since first appearing in the early 1980s, the

Nexus approach has experienced multiple stages of evolution, leading to increasingly complex and diverse nexuses encompassing resource sectors/systems or specific socio-ecological challenges [8]. This evolution positively supports the sustainable development agenda, as a nexus with more components can better reflect reality.

Historically, water, energy, and food sectors have been managed independently, each with its set of policies, stakeholders, and objectives. Such siloed approaches often lead to inefficiencies in resource use, policy conflicts across sectors, and unintended consequences in one sector due to actions in another [4]. Namely, when departments or sectors operate independently, they often lack access to the comprehensive information necessary to make optimal decisions. This can lead to the overuse or wastage of resources. Additionally, without proper coordination, different departments might end up conducting similar tasks or initiatives, leading to redundant efforts and wasted resources.

Furthermore, without a holistic understanding and coordination, policies set by one sector can sometimes undermine or conflict with the objectives of another, whereas potential collaborations or mutual benefits that could arise from integrated planning are overlooked, leading to missed opportunities.

Moreover, actions taken by one department or sector can have unforeseen negative impacts on another. For instance, over-extraction of groundwater for agricultural purposes can deplete local aquifers, affecting drinking water supplies and ecosystem health. Also, a lack of integrated planning means that disruptions in one area (like a drought affecting water supply) can have magnified impacts across other sectors, such as energy and food. Without a cross-sectoral perspective, sectors might not be adequately prepared to adapt or respond to changing conditions or unforeseen challenges. However, as these global challenges mount, the interlinkages between these sectors have become increasingly evident.

The Nexus approach emerges as a response to this realization, advocating for collaborative decision-making that takes into account the broader system, especially synergies and trade-offs among sectors [9]. The WEF Nexus represents the intricate interdependencies between water, energy, and food sectors. Recognizing these connections and managing them coherently is fundamental for sustainable development.

Core interlinkages are determined between:

- Water and Energy: Energy is required to extract, treat, and transport water. Conversely, water is essential for energy production, especially in hydropower and cooling processes for other forms of power generation.
- Water and Food: Agriculture consumes a significant portion of global freshwater resources. Efficient irrigation, soil health, and sustainable agricultural practices play a critical role in managing water resources sustainably.
- Energy and Food: Modern agricultural practices are heavily dependent on energy, especially in terms of machinery, food processing, transportation, and storage.

The main principles underpinning the Nexus approach involve efficiency, sustainability, security, and equity [4, 8-10]. By understanding how sectors influence one another, it becomes possible to identify synergies, which can lead to more efficient use of resources. Taking into account the interdependencies can lead to

more sustainable practices, ensuring that resources are available for future generations. Recognizing the intertwined nature of resources can aid in securing them, ensuring that potential disruptions in one area do not lead to cascading failures across sectors. The Nexus approach promotes fair resource distribution and access, considering the broader societal and environmental implications of decisions.

These principles lead to the crucial benefits steaming from the Nexus approach in terms of policy coherence, innovation, and stakeholder engagement [4, 8-11]. By viewing sectors in conjunction, policies can be designed that avoid potential conflicts and promote mutual benefits. A holistic view often leads to innovative solutions that cater to multiple challenges simultaneously. Recognizing interdependencies often necessitates broader stakeholder involvement, leading to more inclusive decision-making.

#### **4. THE NEXUS GOVERNANCE FRAMEWORK**

Effective governance of the WEF Nexus calls for significant transformations in governance and management systems that currently operate within sectoral boundaries. WEF Nexus governance encompasses a comprehensive understanding of governance covering political, social, economic, and administrative frameworks that influence the utilization of resources and provision of services linked to water, energy, and food [12].

The Nexus governance framework is an integrated approach that emphasizes the importance of understanding and managing the intricate relationships between water, energy, and food. The goal is to foster policies and practices that recognize and navigate these interdependencies in order to achieve sustainable outcomes [13].

The framework is guided by several key principles:

- **Equity:** Ensuring fair access and distribution of resources across sectors and stakeholders.
- **Resilience:** Enhancing the capacity of systems to recover from shocks, ensuring stability even amidst unforeseen challenges.
- **Sustainability:** Prioritizing the long-term health and productivity of natural systems to ensure they can support present and future generations.

The Nexus governance framework requires institutional partnership, i.e., bringing experts from various sectors together to foster understanding and drive collaborative solutions [11, 13]. This involves also policy harmonization, i.e., streamlining policies across sectors to avoid conflicts and trade-offs and promote synergies and mutual benefits [4, 11]. Furthermore, holistic management is needed which involves systems thinking, i.e., viewing sectors not in isolation, but as part of a broader system where alterations in one domain can resonate throughout others, but also recognizing that optimizing one sector might come at a cost to another and striving for solutions that balance these trade-offs.

Nevertheless, the central to the Nexus governance framework is stakeholder engagement as potentiated by various researchers in previous studies [4-5, 8-13]. Engaging a broad spectrum of stakeholders, from policymakers to practitioners, from businesses to local communities, ensures that all voices are heard, whereas maintaining open channels for feedback enables continual refinement and improvement of governance strategies.

## 5. ADVANCING SDGS THROUGH NEXUS GOVERNANCE

The interplay between the WEF Nexus sectors and SDGs is complex. Many SDGs are directly or indirectly tied to the well-being and sustainable management of these sectors, making Nexus governance an essential tool in achieving these global targets [5].

Achieving the SDGs requires all relevant stakeholders to work together and manage the synergies and trade-offs among different management or governance sectors [14]. In particular, the call for integrated implementation of the SDGs requires a horizontal and vertical Nexus approach for achieving coherence across sustainability goals and targets across levels, scales and across regions, strengthening the science-policy-practice interface, and moving beyond silo thinking in natural resource use and management [10-11].

The direct impacts on specific SDGs can be established with [4-5, 8-13]:

- SDG 2 (Zero Hunger): Nexus Governance ensures sustainable agricultural practices, optimized water use, and energy-efficient food production systems, directly contributing to food security.
- SDG 6 (Clean Water and Sanitation): By emphasizing integrated water management, Nexus Governance aims for equitable and sustainable utilization of water resources.
- SDG 7 (Affordable and Clean Energy): The framework promotes energy efficiency and sustainability, emphasizing the symbiotic relationship between water management and energy production.

The indirect benefits can also be identified across multiple SDGs, including but not limited to [5, 8]:

- SDG 1 (No Poverty) and SDG 10 (Reduced Inequality): By promoting equitable access to resources like water, energy, and food, Nexus Governance indirectly supports poverty alleviation and reduced inequalities.
- SDG 3 (Good Health and Well-being): Healthy ecosystems and secure access to clean water and nutritious food, championed by Nexus Governance, play roles in public health.
- SDG 11 (Sustainable Cities and Communities): The integrated approach aids urban areas in managing their resource needs sustainably, leading to more resilient cities.
- SDG 13 (Climate Action): Recognizing the intertwined nature of resources, Nexus Governance aids in the creation of strategies that combat climate change and its impacts.
- SDG 17 (Partnership for the Goals): The very essence of Nexus Governance lies in fostering partnerships and collaborative efforts, directly bolstering this goal.

Notwithstanding identified direct and indirect links and benefits of Nexus governance in advancing SDGs, challenges in the implementation are evident, especially regarding complex decision-making and existing siloed structures. Balancing trade-offs can be daunting, but with inclusive stakeholder engagement and robust data analytics, informed decisions can be made. Besides, overcoming deep-rooted sector-specific practices requires institutional change, capacity building, and education.

## 6. CONCLUSION

In the face of global challenges, isolated siloed approaches referring to the practice of managing, operating, and making decisions within distinct departments, sectors, or areas without sufficient interaction, communication, or coordination with other related entities, fall short. Siloed approaches, while potentially simpler to manage in the short term, often lead to complex, multifaceted challenges in the long run. As the world grows more interconnected, and challenges become more intertwined, there is a pressing need to transition from siloed methodologies to more integrated, holistic strategies that account for the complexities and interdependencies of the modern world.

Advancing SDGs necessitates holistic, integrated frameworks that recognize the delicateness and complexity of interdependencies. Nexus governance, in its embrace of these interconnections, offers a roadmap to a more resilient, sustainable, and equitable future by focusing on the interconnected nature of resources and sectors, as envisioned by the SDGs.

The paper outlines the key role of the Nexus governance in achieving the SDGs. Emphasizing integrated management and interdisciplinary collaboration, this approach offers a route to sustainable global development that is both inclusive and resilient.

The Nexus governance framework, by recognizing the complex ties between water, energy, and food, provides a roadmap for decision-makers to navigate the complexities of modern resource management. It promises not only sustainability but also a more equitable and resilient future, ensuring that resources are used wisely, conflicts are minimized, and societies are better prepared for the challenges ahead.

For the Nexus governance framework to reach its full potential in the context of SDGs it is essential for governments to integrate the Nexus approach at the highest levels of policy-making, while actively engaging the business community, and raising community awareness and education for the ground-level implementation.

## ACKNOWLEDGMENTS

Part of this publication is based upon work from the COST Action <CA20138: Network on water-energy-food Nexus for a low-carbon economy in Europe and beyond – NEXUSNET>, supported by COST (European Cooperation in Science and Technology).

## REFERENCES

- [1] United Nations: **Transforming our world: the 2030 agenda for Sustainable Development**. United Nations, 2015.
- [2] <https://sdgs.un.org/goals> (20.08.2023.)
- [3] Van Tulder Rob, Rodrigues Suzana B., Mirza Hafiz, Sexsmith Kathleen: **The UN's sustainable development goals: Can multinational enterprises lead the decade of action?** *Journal of International Business Policy*, Vol. 4, 1-21, 2021.



- [4] Ioannou Alexandra E., Laspidou Chrysi S.: **Cross-Mapping Important Interactions between Water-Energy-Food Nexus Indices and the SDGs.** *Sustainability*, Vol. 15, No. 10, 8045, 1-14, 2023.
- [5] Hülsmann Stephan, Ardakanian Reza: **The nexus approach as tool for achieving SDGs: trends and needs.** In *Managing water, soil and waste resources to achieve sustainable development goals: monitoring and implementation of integrated resources management* (pp. 1-9). Springer International Publishing AG, Cham, 2018.
- [6] <https://www.un.org/sustainabledevelopment/news/communications-material/> (20.08.2023.)
- [7] United Nations: **The Sustainable Development Goals Report 2023 Special Edition: Towards a Rescue Plan for People and Planet.** United Nations, 2023.
- [8] Estoque Ronald C.: (2023). **Complexity and diversity of nexuses: A review of the nexus approach in the sustainability context.** *Science of The Total Environment*, Vol. 854, 158612, 1-12, 2023.
- [9] Bleischwitz Raimund, Spataru Catalina, Van Deveer Stacy D., Obersteiner Michael, van der Voet Ester, Johnson Corey, Andrews-Speed Philip, Boersma Tim, Hoff Holger, van Vuuren Detlef P.: **Resource nexus perspectives towards the United Nations Sustainable Development Goals.** *Nature Sustainability*, Vol. 1, No. 12, 737-743, 2018.
- [10] Hoff Holger: **Integrated SDG Implementation – How a Cross-Scale (Vertical) and Cross-Regional Nexus Approach Can Complement Cross-Sectoral (Horizontal) Integration.** In *Managing water, soil and waste resources to achieve sustainable development goals: monitoring and implementation of integrated resources management* (pp. 149-163). Springer International Publishing AG, Cham, 2018.
- [11] Tudose Nicu Constantin, Marin Mirabela, Cheval Sorin, Mitter Hermine, Broekman Annelies, Sanchez-Plaza Anabel, Ungurean Cezar, Davidescu Serban: **Challenges and opportunities of knowledge co-creation for the water-energy-land nexus.** *Climate Services*, Vol. 30, 100340, 1-13, 2023.
- [12] Pahl-Wostl Claudia: **Governance of the water–energy–food nexus: a multi-level coordination challenge.** *Environmental Science and Policy*, Vol. 92, 356-367, 2019.
- [13] Dombrowsky Ines: **Implementing the 2030 Agenda under Resource Scarcity: The Case of WEF Nexus Governance in Azraq/Jordan.** In *Governing the Interlinkages between the SDGs* (pp. 124-139). Routledge, 2022.
- [14] Liu Jianguo, Hull Vanessa, Godfray Charles H. J., Tilman David, Gleick Peter, Hoff Holger, Pahl-Wostl Claudia, Xu Zhenci, Chung Min Gon, Sun Jing, Li Shuxin: **Nexus approaches to global sustainable development.** *Nature Sustainability*, Vol. 1, No. 9, 466-476, 2018.

## LIST OF REVIEWERS

- Assistant professor Alfirević Đorđe**, PhD, Faculty of contemporary arts, Belgrade, Serbia  
**Associate Professor Asparuhov Stefan**, PhD University of Architecture, Civil Engineering and Geodesy (UACG), Sofia, Bulgaria  
**Professor Beatrice-Gabriela Jöger**, PhD, Ion Mincu University of Architecture and Urbanism, Bucharest, Romania  
**Associate Professor Bogdanović Protić Ivana**, PhD, Faculty of Civil Engineering and Architecture, University of Niš, Serbia  
**Professor Bonić Zoran**, PhD, Faculty of Civil Engineering and Architecture, University of Niš, Serbia  
**Associate Professor Bulatović Vesna**, PhD, Faculty of Technical Sciences, University of Novi Sad, Serbia  
**Čokić Miloš**, PhD, S. E. Designer, Termoenergo inženjering Belgrade, Serbia  
**Research Associate Čolić Nataša**, PhD, Institute of Architecture and Urban & Spatial Planning of Serbia, (IAUS), Belgrade, Serbia  
**Assistant Professor Đekić Jelena**, PhD, Faculty of Civil Engineering and Architecture, University of Niš, Serbia  
**Assistant Professor Despotović Iva**, PhD, Faculty of Mechanical and Civil Engineering in Kraljevo, University of Kragujevac, Serbia  
**Associate Professor Dinić Branković Milena**, PhD, Faculty of Civil Engineering and Architecture, University of Niš, Serbia  
**Professor Đorić Veljković Snežana**, PhD, Faculty of Civil Engineering and Architecture, University of Niš, Serbia  
**Assistant Professor Dulić Olivera**, PhD, University of Novi Sad, Faculty of Civil Engineering Subotica, Serbia  
**Senior Lecturer Flor Jan-Frederik**, PhD, University of Malaysia, Kelantan, Malaysia  
**Assistant Gligorijević Milan**, PhD, Faculty of Civil Engineering and Architecture, University of Niš, Serbia  
**Professor Gocić Milan**, PhD, Faculty of Civil Engineering and Architecture, University of Niš, Serbia  
**Assistant Professor Grdić Dušan**, PhD, Faculty of Civil Engineering and Architecture, University of Niš, Serbia  
**Professor Grdić Zoran**, PhD, Faculty of Civil Engineering and Architecture, University of Niš, Serbia  
**Associate Professor Horáček Martin**, PhD, Brno University of Technology, Czech Republic  
**Assistant Professor Ilić Aleksandra**, PhD, Faculty of Civil Engineering and Architecture, University of Niš, Serbia  
**Associate Professor Ivanova Alexandra**, PhD, University of Structural Engineering & Architecture "Lyuben Karavelov", Sofia, Bulgaria  
**Professor Ivanova Blagovesta**, DSc, University of Structural Engineering & Architecture "Lyuben Karavelov", Sofia, Bulgaria  
**Associate Professor Janković Predrag**, PhD, Faculty of Mechanical Engineering, University of Niš, Serbia  
**Assistant Professor Jevremović Ljiljana**, PhD, Faculty of Civil Engineering and Architecture, University of Niš, Serbia  
**Professor Jovanovski Milorad**, PhD, Department of Geotechnical Engineering, Civil Engineering Faculty, "St. Cyril and Methodius" University, Skopje, Republic of N. Macedonia  
**Assistant Professor Knežević Petar**, PhD, State University of Novi Pazar, Serbia  
**Assistant Professor Kondić Slaviša**, PhD, Faculty of Civil Engineering and Architecture, University of Niš, Serbia  
**Professor Krsić Sonja**, PhD, Faculty of Civil Engineering and Architecture, University of Niš, Serbia  
**Professor Krklješ Milena**, PhD, Faculty of Technical Sciences, University of Novi Sad, Serbia  
**Assistant Professor Krstić Hristina**, PhD, Faculty of Civil Engineering and Architecture, University of Niš, Serbia  
**Assistant Professor Ljubenović Milica**, PhD, Faculty of Civil Engineering and Architecture, University of Niš, Serbia  
**Associate Professor Mangaroska Viktorija**, PhD, Faculty of Architectural Engineering, International Balkan University, Republic of N. Macedonia  
**Senior Research Fellow Manić Božidar**, PhD, Institute of Architecture and Urban & Spatial Planning of Serbia (IAUS), Belgrade, Serbia  
**Associate Professor Marchwiński Janusz**, University of Ecology and Management, Warsaw, Poland  
**Associate Professor Marković Milica**, PhD, Faculty of Civil Engineering and Architecture, University of Niš, Serbia  
**Assistant Professor Miljković Miomir**, PhD, Faculty of Civil Engineering and Architecture, University of Niš, Serbia
-

- Assistant Professor Milošević Bojan**, PhD, Faculty of Mechanical and Civil Engineering, University of Kragujevac, Kraljevo, Serbia
- Associate Professor Milošević Vuk**, PhD, Faculty of Civil Engineering and Architecture, University of Niš, Serbia
- Research Associate Milović Tiana**, PhD, Faculty of Technical Sciences, University of Novi Sad, Serbia
- Associate Professor Miškeljin Ivana**, PhD, Faculty of Technical Sciences, University of Novi Sad, Serbia
- Associate Professor Momčilović Petronijević Ana**, PhD, Faculty of Civil Engineering and Architecture, University of Niš, Serbia
- Assistant Professor Nikolov Peter**, PhD, Faculty of Architecture, Department of Architecture and Urban Studies, VFU "Chernorizets Hrabar", Varna, Bulgaria
- Assistant Professor Petković Nataša**, PhD, Faculty of Civil Engineering and Architecture, University of Niš, Serbia
- Assistant Professor Rađenović Tamara**, PhD, Faculty of Occupational Safety, University of Niš, Serbia
- Associate Professor Rajčić Aleksandar**, PhD, Faculty of Architecture, University of Belgrade, Serbia
- Assistant Professor Ranđelović Dušan**, PhD, Faculty of Civil Engineering and Architecture, University of Niš, Serbia
- Assistant Professor Ranković Slobodan**, PhD, Faculty of Civil Engineering and Architecture, University of Niš, Serbia
- Lecturer Roshi Artur**, PhD, Metropolitan University, Tirana, Albania
- Assistant Professor Savić Jelena**, PhD, Faculty of Civil Engineering and Architecture, University of Niš, Serbia
- Professor, Sekulić Goran**, PhD, Faculty of Civil Engineering Podgorica, University of Montenegro
- Senior research fellow Simonović Alfirević Sanja**, PhD, Institute of Architecture and Urban & Spatial Planning of Serbia, (IAUS), Belgrade, Serbia
- Adjunct Lecturer Skoulikaris Charalampos**, PhD, Aristotle University of Thessaloniki, Greece
- Assistant Professor Stamenković Marija**, PhD, Faculty of Technical Sciences in Kosovska Mitrovica, University of Priština, Serbia
- Assistant Professor Stanimirović Mirko**, PhD, Faculty of Civil Engineering and Architecture, University of Niš, Serbia
- Assistant Professor Stojanović Krsić Marija**, PhD, Faculty of Mechanical Engineering, University of Niš, Serbia
- Associate Professor Stojiljković Branislava**, PhD, Faculty of Civil Engineering and Architecture, University of Niš, Serbia
- Senior research associate Stojković Milan**, PhD, Institute for Artificial intelligence R&D of Serbia
- Senior Lecturer Stojković Nenad**, PhD, Academy of Applied Technical and Educational Studies in Niš, Serbia
- Lecturer Ljiljana Stošić Mihajlović**, PhD Academy of technical educational studies, Niš – department in Vranje, Serbia
- Associate Professor Trajković Milenković Marina**, PhD, Faculty of Civil Engineering and Architecture, University of Niš, Serbia
- Professor Trajković Slaviša**, PhD, Faculty of Civil Engineering and Architecture, University of Niš, Serbia
- Senior lecturer Trifunović-Drađišić Vesna**, PhD, College of Civil Engineering and Geodesy, Academy of Technical and Artistic Vocational Studies, Belgrade, Serbia
- Associate Professor Tritthart Michael**, PhD, University of Natural Resources and Life Sciences (BOKU), Wien, Austria
- Professor Vacev Todor**, PhD, Faculty of Civil Engineering and Architecture, University of Niš, Serbia
- Professor Vasov Miomir**, PhD, Faculty of Civil Engineering and Architecture, University of Niš, Serbia
- Assistant Professor Velimirović Nikola**, PhD, State University of Novi Pazar, Serbia
- Assistant Professor Vukadinović Ana**, PhD, Faculty of Occupational Safety, University of Niš, Serbia
- Associate professor Zafirovski Zlatko**, PhD, Faculty of Civil Engineering Skopje, Ss. Cyril and Methodius University in Skopje, Republic of N. Macedonia
- Associate Professor Zielonko-Jung Katarzyna**, Faculty of Architecture, Gdańsk University of Technology, Poland
- Planner and Consultant Živaljević Luxor Nataša**, PhD, PE Urban Planning Institute Niš, Serbia
- Associate Professor Zlatanović Elefterija**, PhD, Faculty of Civil Engineering and Architecture, University of Niš, Serbia
- Assistant Professor Zorić Andrija**, PhD, Faculty of Civil Engineering and Architecture, University of Niš, Serbia
-

## SPONSORS

# PLATINUM PLUS SPONSOR

*Put Inženjering Niš*

| <https://putinzenjering.com> |



# PUT INŽENJERING

### Niš

📍 Ruzmarina 25, Donja Vrežina,  
18103 Niš

☎ + (381) 18 215 355

@ office@putinzenjering.com

🕒 Pon - Pet: 07 - 15h

### Nova Pazova

📍 Prva centralna radna 3, 22330  
Nova Pazova

☎ + (381) 22 215 22 25

@ mobeco@putinzenjering.com

🕒 Pon - Pet: 07 - 15h

### Gradimo širom regiona



# PLATINUM SPONSORS

---

*Građevinarska direkcija Srbije Beograd*

| <https://gds.rs> |



*Project Biro UTIBER Novi Sad*

| <http://www.utiber.rs> |



# GOLDEN SPONSOR

*Kapaprojekt Niš*

| <https://kapaprojekt.com> |



## KAPAPROJEKT

*Inženjerska komora Srbije*

| <https://www.ingkomora.rs/> |



ИНЖЕЊЕРСКА  
КОМОРА  
СРБИЈЕ

# SILVER SPONSORS

*ArhiBET Niš*

| <https://www.arhibet.rs> |



arhibet  
UMET  
RUKO  
POPLO  
GAVI  
NJA



www.arhibet.rs

**Apokrifi Niš**

| <http://apokrifi.com> |



Apokrifi Ltd. is a team of engineers that assists clients in Europe and Serbia to more efficiently realize their projects, reduce costs, and increase profits.

We specialize in:

- ✓ Structural design,
- ✓ Structural analysis,
- ✓ Reinforcement detailing,
- ✓ Formwork detailing,
- ✓ Creation of files (PXML, UNITECHNICK) necessary for the production of prefabricated structures and elements,
- ✓ 3D modeling.



**APOKRIFI**

**Tončev gradnja**

| <http://www.toncev.com/> |



**TONČEV GRADNJA**  
SURDULICA

**GEBERIT prodaja Beograd**

| <https://www.geberit.rs> |



**Moravacem d.o.o. Popovac**

| <https://moravacem.rs> |



## BRONZE SPONZORS

**Projektinženjering Tim Niš**

| <https://www.projektinzenjering.com> |



## PROJEKTINŽENJERING

**Mc Bauchemie, Beograd**

| <https://www.mc-bauchemie.rs> |



**LHR Beograd**

| <https://lhr.rs> |





**AD Crna Trava Leskovac** | <https://ad-crna-trava-preduzece-za.business.site/>



---

**HSV d.o.o. Vlasotince** | <https://www.hsv.rs/>



---

**Sika Srbija d.o.o. Šimanovci** | <https://srb.sika.com/>



## Građevinska direkcija Srbije- više od kvadrata



Građevinska direkcija Srbije d.o.o. Beograd je osnovana odlukom Vlade Republike Srbije 2001. godine, radi upravljanja projektima od značaja za državu, prvenstveno za upravljanje investicijama u građevinarstvu.

U našim timovima su viskokvalifikovani stručnjaci različitih profila: građevinske, arhitektonske, mašinske, elektrotehničke i drugih struka koji duže od dve decenije upravljaju izgradnjom objekata različitih namena - komercijalnih, stambeno-poslovnih, infrastrukturnih i tehnoloških.

Stručnjaci Građevinske direkcije Srbije (GDS) vrše stručni nadzor nad rekonstrukcijom i sanacijom objekata na područjima zahvaćenim elementarnim nepogodama, obavljaju konsultantske aktivnosti u vezi s poslovanjem i upravljanje u oblasti arhitektonske i inženjerske delatnosti, delatnosti tehničkog savetovanja.

S ponosom ističemo da je Građevinska direkcija Srbije do sada **realizovala niz razvojnih i komercijalnih, građevinskih i investicionih projekata na čitavoj teritoriji Republike Srbije u ukupnoj vrednosti od oko 1.400.000.000 EUR.**

### Aktuelni projekti:

- Upravljanje projektom izgradnje Nacionalnog stadiona i kompleksa za Međunarodnu izložbu EXPO 2027 u Surčinskom polju
  - površina parcele oko 200 ha
  - Nacionalni stadion sa 52.000 sedišta
  - kompleks EXPO 2027
  - stambeni prostor
  - komercijalni sadržaji
  - linijska infrastruktura u funkciji kompleksa (gradski bulevari, saobraćajna petlja, parking, linije gasovoda, toplovoda, vodovoda)
  - savremene tehnologije
  - održivi i energetske efikasni objekti



## Najznačajniji projekti:

- Naselje Stepa Stepanović, Voždovac, Beograd
  - 42 ha naselja
  - 434.000 m<sup>2</sup> stambeno-poslovnog prostora
  - 4.616 stanova
  - 3.300 parking mesta
  - 9,5km novi saobraćajnica
- Stambeno–poslovni kompleks PETICA, Novi Beograd
  - 308 luksuznih stanova
  - 60.000m<sup>2</sup> stambeno- poslovnog prostora
  - atraktivni penthouse stanovi sa panoramskim pogledom
  - moderan poslovni prostor
- Naselje Zemunske kapije, Beograd
  - 200.000m<sup>2</sup> stambeno-poslovnig prostora
  - 1.440 stanova
  - komercijalni sadžaji, zelene površine, dečja igrališta
- Centrala Poreske uprave Srbije
  - 27.500m<sup>2</sup> modernog poslovnog prostora
  - atraktivna arhitektonska rešenja
  - zeleni krov
  - energetski efikasan objekat
- Stanovi za pripadnike snaga bezbednosti
  - Više od 7.000 stambenih jedinica izgrađenih od 2019. godine u Beogradu, Novom Sadu, Sremskoj Mitrovici, Kragujevcu, Kraljevu, Nišu i Vranju
- Granični prelazi Horgoš, Batrovci, Preševo



## Građevinska direkcija Srbije

- 19.000 stanova
- 1.800.000 m<sup>2</sup> stambeno-poslovnog prostora
- Stanogradnja
- Upravljanje i nadzor
- Upravljanje velikim državnim projektima
- Izgradnja i rekonstrukcija graničnih prelaza
- Rekonstrukcije i adaptacije objekata
- Sanacija posledica elementarnih nepogoda

Građevinska direkcija Srbije d.o.o.  
Jurija Gagarina 76  
11073 Novi Beograd  
[www.gds.rs](http://www.gds.rs)

CIP - Каталогизација у публикацији  
Народна библиотека Србије, Београд

624(082)  
72(082)

**INTERNATIONAL Conference Synergy of Architecture & Civil Engineering (2023 ; Niš)**

Proceedings [of] The International Conference Synergy of Architecture & Civil Engineering, SINARG 2023, Niš (Serbia), September 14-15, 2023. Vol. 2 / [editors Slaviša Trajković, Vuk Milošević] ; [organized by University of Niš, Faculty of Civil Engineering and Architecture [and] Serbian Academy of Sciences and Arts - Branch in Niš [and] Serbian Academy of Sciences and Arts - Department of Technical Sciences]. - Niš : University, Faculty of Civil Engineering and Architecture : SASA, Branch in Niš, 2023 (Niš : Grafika Galeb). - [12] str., str. 597-1187 : ilustr. ; 24 cm

Tiraž 100. - Str. [9]: Preface / Editors. - Bibliografija uz svaki rad.

ISBN 978-86-88601-81-8  
ISBN 978-86-88601-82-5 (niz)

а) Грађевинарство -- Зборници б) Архитектура – Зборници

COBISS.SR-ID 123837961